

EASY, ECONOMICAL SINGLE CAVITY VALVE GATING

An advanced inline design proven to deliver consistent high performance processing capabilities for exceptional part quality. Available with the broadest shot range capacity and widest range of resin compatibility. The ideal choice for high volume production or prototyping, of the smallest to largest parts, with applications across any industry.

KEY FEATURES

FULLY INTEGRATED IN-LINE MANIFOLD DESIGN

- Reduces mold backing plate thickness by 67%.
- Valve gated for larger process window.
- Greater durability vs. off-centre designs.
- Large runner profile improves resin flow.
- Incorporates high temperature Viton seals.
- Reliable leakage protection.

SINGLE ZONE HEATED BODY

- Superior thermal uniformity.
- Enhances molding process control.
- Improves part quality.
- Minimizes scrap.

WATER COOLING CHANNELS

- Hose or Direct Mold Connection.
- Minimizes component misalignments from heat expansion.
- Maintains system integrity.
- Ensures long term reliability.

BRAZED HEATER TECHNOLOGY

- Superior reliability maximizes uptime.
- Eliminate spare heater costs.
- Energy efficient.



Pneumatic and hydraulic actuation

UP TO 67% STACK-HEIGHT REDUCTION

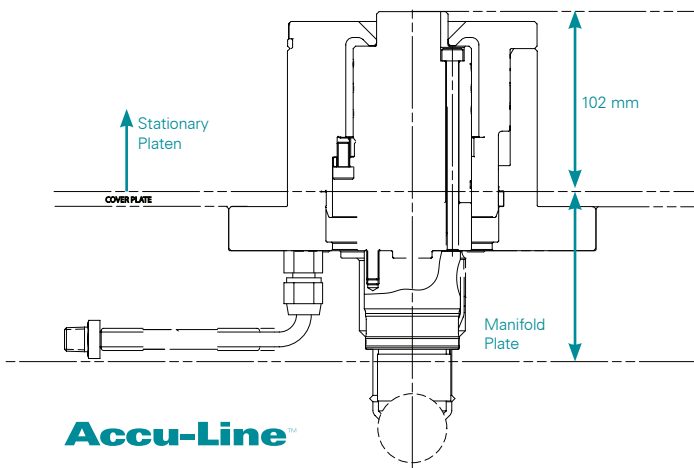

Accu-Line™

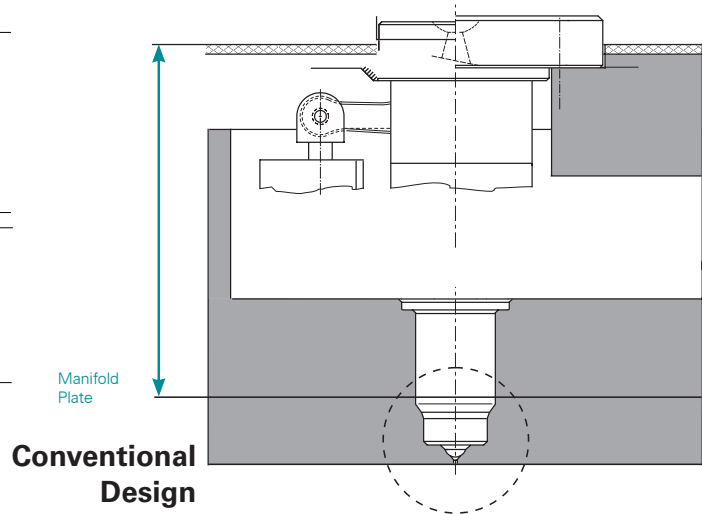

Conventional Design

COOLING CIRCUIT

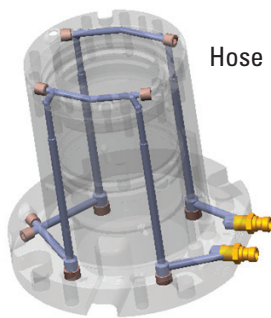

Hose connection

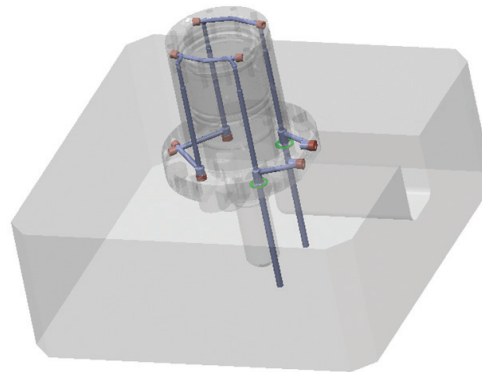

Mold direct connection (optional)

SPECIFICATIONS

NOZZLE RANGE	Shot Size (g)	Nozzle Lengths (mm)	Valve Pin ϕ (mm)	Runner ϕ (mm)	Body Style	Stroke Height (mm)	Outer dia. Sizes (mm)
FEMTO*	<10	40-205	2.5/3	6/7	B1/ B8	2.0/ 10.0	99.80/ 101.34/ 109.75
PICO*	10-20	31-221	3	7	B1	2.5/ 10.0	99.80/ 101.34/ 109.75
CENTI	15-50	25-224	3	8	B1	3.0/ 10.0	99.80/ 101.34/ 109.75
DECI	50-500	35-253	5	11	B1	3.5/ 10.0/ 15.0	99.80/ 101.34/ 109.75
HECTO	500-3500	50-488	8	16	B1	20.0	99.80/ 101.34/ 109.75
HECTO	500-3500	50-488	8	18	B4	20.0	99.80/ 101.34/ 109.75

*Adapter plate required



TempMaster™ series Mt

For peak performance and superior results, Mold-Masters recommends using TempMaster MT controllers with all Accu-Line Hot Runner systems. Unlock your operations full potential with TempMaster.