

TempMaster™ series *Mt*

User Manual

version 4



REMOVE AND KEEP THIS
SHEET SOMEWHERE SAFE

MT Controllers come with a fixed password which is
entered via the two arrow keys.

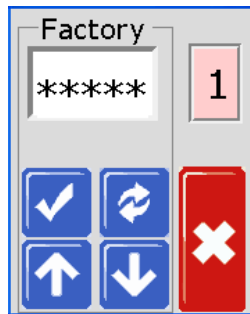

The Password is:



(up, down, up, up, down)

followed by a check mark



Table of Contents

Section 1 - Introduction	1-1
1.1 Intended Use	1-1
1.2 Release Details	1-1
1.3 Warranty Details	1-1
1.4 Returned Goods Policy.....	1-1
1.5 Movement or Resale of Mold-Masters Products or Systems	1-1
1.6 Copyright	1-2
1.7 Units of Measure and Conversion Factors	1-2
1.8 Trademarks and Patents	1-3
 Section 2 - Global Support	 2-1
2.1 Manufacturing Facilities	2-1
2.2 Regional Offices	2-1
2.3 International Representatives	2-2
 Section 3 - Safety.....	 3-1
3.1 Introduction.....	3-1
3.2 Safety Hazards	3-2
3.3 Operational Hazards.....	3-5
3.4 General Safety Symbols.....	3-7
3.5 Wiring Check	3-8
3.6 Lockout Safety.....	3-9
3.7 Electrical Lockout	3-10
3.7.1 Energy Forms and Lockout Guidelines.....	3-11
3.8 Disposal.....	3-12
3.9 MT/MT2 Controller User Hazards.....	3-13
 Section 4 - Overview	 4-1
4.1 Specification	4-2
4.2 TMXL/MT Compatibility	4-2
4.3 Tool Connections	4-3
4.4 Controller Power Supplies	4-3
4.5 Filter Option.....	4-3
4.6 Switch On and Off.....	4-3
4.6.1 Switch On	4-3
4.6.2 Switch Off Individual Modules.....	4-3
4.6.3 Switch Off the Whole Controller.....	4-3
4.6.4 Switch Off Individual Zones	4-4
4.7 Controller Cabinet.....	4-4
4.7.1 Controller Modules	4-5
4.8 How the MT Controller Works.....	4-6
4.8.1 Set the Ramp Feature (On / Off)	4-6
4.9 Program Menus	4-7

Section 5 - Setup	5-1
5.1 Introduction	5-2
5.2 Set Zone Numbering	5-3
5.3 Set the Temperature Scale	5-5
5.4 Change Zone PID Characteristics	5-7
5.5 Set the Ramp Feature	5-9
5.6 Set Boost Value	5-11
5.7 Set Standby Value	5-13
5.8 Monitor Temperature Limits	5-15
5.8.1 Warning and Alarm Limits	5-15
5.9 Set Ground Fault Detection	5-17
5.10 Set Mold Leak Detection	5-19
5.11 Set Response to Thermocouple Failure	5-21
5.12 Restrict Access to Manual, Standby or Boost.....	5-23
5.13 Extend Alarms for Manual, Standby or Boost Operation	5-25
5.14 Language.....	5-27
5.15 Set the Required Zone Temperatures	5-28
 Section 6 - Operation	 6-1
6.1 Run Mode	6-1
6.2 OFF Mode (Single Zone).....	6-2
6.3 Off Mode (Single Module).....	6-2
6.4 Manual Mode.....	6-3
6.5 Manual Mode - Power Level.....	6-4
6.6 Slave Mode.....	6-5
6.7 Standby and Boost Mode	6-7
6.7.1 Standby – Whole Cabinet.....	6-7
6.7.2 Boost – Whole Cabinet.....	6-7
6.7.3 No Standby or Boost Option	6-7
6.8 Standby Mode – Individual Zones	6-8
6.9 Leaving Standby Mode.....	6-9
6.10 Boost Mode – Individual Zones	6-10
6.11 Change Set Temperature (Auto or Manual).....	6-11
 Section 7 - Maintenance.....	 7-1
7.1 Service and Repair The Controller	7-1
7.1.1 Replacement Parts	7-1
7.1.2 Cleaning and Inspection	7-1
7.2 Restore Factory Settings and Recalibration	7-2
7.2.1 Default Settings	7-3
7.2.2 Calibration Routine	7-3
7.2.3 Calibration Sequence	7-3
7.2.4 M.Dis Option.....	7-4
7.3 Fuses and Overcurrent Protection.....	7-5
7.3.1 Fans.....	7-5
7.3.2 Controller Cards.....	7-6
7.3.3 Onboard Power Supply.....	7-6
7.3.4 Output Fuse Type: HRC High Speed.....	7-6
7.3.5 Input Fuse Type: Surface-Mount Quick-Blow	7-6

Section 8 - Troubleshooting8-1

- 8.1 Individual Card Diagnostics8-1
- 8.2 Other Possible Fault Conditions8-3
 - 8.2.1 Rapid Temperature Fluctuations8-3
 - 8.2.2 Ground Fault Detection.....8-3
- 8.3 Module Removal.....8-3

Section 9 - Wiring Details9-1

- 9.1 Single Phase Supply Cable9-1
- 9.2 Three Phase Designation9-2
 - 9.2.1 Five Wire Star 380VAC9-2
 - 9.2.2 Set Power Terminal Block to STAR Configuration9-3
 - 9.2.3 For Four Wire Delta 240V.....9-4
 - 9.2.4 Set Power Terminal Block To DELTA Configuration9-5
- 9.3 Filter Option9-6
- 9.4 Alarm Output.....9-6
- 9.5 Standard Tool Connections9-7
 - 9.5.1 MT-02-029-7
 - 9.5.2 MT-02-02 For UK and Europe9-7
 - 9.5.3 MT-02-02 For India9-8
 - 9.5.4 MT-02-02 For North America9-9
 - 9.5.5 MT-04-049-10
 - 9.5.6 MT-06-069-11
 - 9.5.7 MT-12-12 and MT-18-xx9-12
 - 9.5.8 MT-12-12 and MT-18-xx for UK and Europe.....9-12
 - 9.5.9 MT-12-12 and MT-18-xx for North America9-14

Index I

List of Tables

Table 1-2 Units of Measure and Conversion Factors	1-2
Table 3-1 Safety Hazards	3-3
Table 3-2 Typical Safety Symbols.....	3-7
Table 3-3 Energy Forms, Energy Sources and General Lockout Guidelines	3-11
Table 4-1 General Specifications.....	4-2
Table 5-1 Factory Settings.....	5-2
Table 7-1 Factory Settings.....	7-3
Table 7-2 Fan Fuses.....	7-6
Table 7-3 Onboard Power Supply Fuse.....	7-6
Table 7-4 Output Fuse Type	7-6
Table 7-5 Input Fuse Type	7-6
Table 8-1 Alarm Conditions.....	8-1
Table 9-1 Cable Markings for Single Phase Supply Cable (MT-02-02).....	9-1
Table 9-2 Cable Markings - 5 Wire Star.....	9-1
Table 9-3 Cable Markings for Four Wire Star	9-3
Table 9-4 HAN4A Pin Connections.....	9-5
Table 9-5 MT-02-02 Pin Configuration for UK and Europe.....	9-6
Table 9-6 MT-02-02 Pin Configuration for India.....	9-7
Table 9-7 MT-02-02 Pin Configuration for North America.....	9-8
Table 9-8 MT-04-04 Pin Configuration.....	9-9
Table 9-9 MT-06-06 Pin Configuration.....	9-10
Table 9-10 MT-12-12 / MT-18-xx Pin Configuration for UK and Europe	9-12
Table 9-11 MT-12-12 / MT-18-xx Pin Configuration for North America (Plug 1)	9-13
Table 9-12 MT-12-12 / MT-18-xx Pin Configuration for North America (Plug 2)	9-14

List of Figures

Figure 3-1 Injection molding machine hazard areas.....	3-2
Figure 4-1 MT controller	4-1
Figure 4-2 MT2 controller	4-1
Figure 4-3 MT Menu	4-7
Figure 4-4 MT2 Menu	4-7
Figure 7-1 Fuse location on a controller card	7-5
Figure 9-1 Connect the neutral - position shown by blue arrow.....	9-2
Figure 9-2 Install the three way link.....	9-2
Figure 9-3 Remove the neutral wire - position shown by the blue arrow.....	9-4
Figure 9-4 Install the three 2-way links.....	9-4
Figure 9-5 HAN4A connector.....	9-5
Figure 9-6 Harting Han 10 A® insert for MT-02-02.....	9-6
Figure 9-7 Harting Han 10 A® cut out dimensions	9-6
Figure 9-8 Harting Han 16 E® insert for MT-02-02.....	9-7
Figure 9-9 Harting Han 16 E® cut out dimensions	9-7
Figure 9-10 Harting Han 10 E® insert for MT-02-02	9-8
Figure 9-11 Harting Han 10 E® cut out dimensions	9-8
Figure 9-12 Insert for MT-04-04.....	9-9
Figure 9-13 MT-04-04 cut out dimensions.....	9-9
Figure 9-14 Insert for MT-06-06.....	9-10
Figure 9-15 MT-06-06 cut out dimensions.....	9-10
Figure 9-16 Inserts for MT-12-12 and MT-18-xx.....	9-11
Figure 9-17 MT-12-12 AND MT-18-xx cut out dimensions - UK and Europe	9-12
Figure 9-18 MT-12-12 and MT-18-xx inserts (Plug 1 and Plug 2)	9-13
Figure 9-19 MT-12-12 AND MT-18-xx cut out dimensions - North America	9-14

Section 1 - Introduction

The purpose of this manual is to assist users in the integration, operation and maintenance of the MT and MT2 controller. This manual is designed to cover most system configurations. If you need additional information specific to your system please contact your representative or a *Mold-Masters* office whose location can be found in the “Global Support” section.

1.1 Intended Use

The MT Series controllers have been designed as a multi-channel temperature controllers for use in hot runner plastic molding equipment. They use feedback from thermocouples within the nozzles and manifolds to give precise closed-loop temperature control, and they are designed to be safe during normal operation. Any other uses would fall outside the engineered intent of this machine which may be a safety hazard and would void any and all warranties.

This manual is written for use by skilled persons who are familiar with injection molding machinery and their terminology. Operators should be familiar with plastic injection molding machines and the controls of such equipment. Maintenance persons should have sufficient understanding of electrical safety to appreciate the dangers of 3-phase supplies. They should know how to take appropriate measures to avoid any danger from electrical supplies.

1.2 Release Details

Table 1-1 Release Details		
Document Number	Release Date	Version
MT-UM-EN-00-04-5	July 2019	04-5

1.3 Warranty Details

Warranty details are provided with your order documentation.

1.4 Returned Goods Policy

Please do not return any parts to *Mold-Masters* without pre-authorization and a return authorization number supplied by *Mold-Masters*.

Our policy is one of continuous improvement and we reserve the right to alter product specifications at any time without giving notice.

1.5 Movement or Resale of Mold-Masters Products or Systems

This documentation is intended for use in the country of destination for which the product or system was purchased.

Mold-Masters takes no responsibility for documentation of products or systems if they are relocated or resold outside the intended country of destination, as stated on the accompanying invoice and/or waybill.

1.6 Copyright

© 2019 Milacron LLC. All Rights Reserved. *Mold-Masters*® and the *Mold-Masters* logo are trademarks of Milacron LLC and/or its affiliates *Mold-Masters* (2007) Limited, DME Company LLC, and Cimcool Fluid Technology. (collectively, “Milacron”).

1.7 Units of Measure and Conversion Factors



NOTE

The dimensions given in this manual are from original manufacturing drawings.

All values in this manual are in S.I. units or subdivisions of these units. Imperial units are given in parenthesis immediately after the S.I. units.

Table 1-2 Units of Measure and Conversion Factors		
Abbreviation	Unit	Conversion Value
bar	Bar	14.5 psi
in.	Inch	25.4 mm
kg	Kilogram	2.205 lb
kPa	Kilopascal	0.145 psi
gal	Gallon	3.785 l
lb	Pound	0.4536 kg
lbf	Pound force	4.448 N
lbf.in.	Pound force inch	0.113 Nm
l	Litre	0.264 gallon
min	Minute	
mm	Millimeter	0.03937 in.
mΩ	Milli Ohm	
N	Newton	0.2248 lbf
Nm	Newton Meter	8.851 lbf.in.
psi	Pound per square inch	0.069 bar
psi	Pound per square inch	6.895 kPa
rpm	Revolutions per minute	
s	Second	
°	Degree	
°C	Degree Celsius	0.556 (°F -32)
°F	Degree Fahrenheit	1.8 °C +32

1.8 Trademarks and Patents

ACCU-VALVE, DURA, FLEX-DURA FLEX-SERIES, FUSION-SERIES, HOT EDGE, INJECTION-EERING, MASTERPROBE, MASTER-SHOT, MOLD-MASTERS, MELT-DISK, MOLD-MASTERS ACADEMY, MASTER-SERIES, MASTERSOLUTION, MASTERSPEED, MERLIN, MOLD-MASTERS SYSTEM, MPET, SCAN-MASTER, STACK-LINK, are the registered trademarks of MOLD-MASTERS (2007) LIMITED.

Information contained herein is, to our best knowledge, true and accurate, but all recommendations or suggestions are made without guarantee. Since the conditions of use are beyond our control, *Mold-Masters* disclaims any liability incurred in connection with the use of our products and information contained herein. No person is authorized to make any statement or recommendation not contained herein, and any such statement or recommendation so made shall not bind *Mold-Masters*. Furthermore, nothing contained herein shall be construed as a recommendation to use any product in conflict with existing patents covering any products or its use, and no license implied or in fact granted herein under the claims of any patents.

No part of this publication may be reproduced or transmitted in any form or by any means, electronic or mechanical, including photocopy, recording, or any information storage and retrieval system without permission in writing from the publisher. All details, standards and specifications may be altered in accordance with technical development without prior notification.

May be manufactured under one or more of the following U.S. Patents:

5792493, 5795599, 5820899, 5843361, 5849343, 5853777, 5935615, 5935616, 5935621, 5942257, 5952016, 5980236, 6009616, 6017209, 6030198, 6030202, 6062841, 6074191, 6077067, 6079972, 6095790, 6099780, 6113381, 6135751, 6162043, 6162044, 6176700, 6196826, 6203310, 6230384, 6270711, 6274075, 6286751, 6302680, 6318990, 6323465, 6348171, 6350401, 6394784, 6398537, 6405785, 6440350, 6454558, 6447283, 6488881, 6561789, 6575731, 6625873, 6638053, 6648622, 6655945, 6675055, 6688875, 6701997, 6739863, 6752618, 6755641, 6761557, 6769901, 6776600, 6780003, 6789745, 6830447, 6835060, 6840758, 6852265, 6860732, 6869276, 6884061, 6887418, 6890473, 6893249, 6921257, 6921259, 6936199, 6945767, 6945768, 6955534, 6962492, 6971869, 6988883, 6992269, 7014455, 7018197, 7022278, 7025585, 7025586, 7029269, 7040378, 7044191, 7044728, 7048532, 7086852, 7105123, 7108502, 7108503, 7115226, 7118703, 7118704, 7122145, 7125242, 7125243, 7128566, 7131832, 7131833, 7131834, 7134868, 7137806, 7137807, 7143496, 7156648, 7160100, 7160101, 7165965, 7168941, 7168943, 7172409, 7172411, 7175419, 7175420, 7179081, 7182591, 7182893, 7189071, 7192268, 7192270, 7198740, 7201335, 7210917, 7223092, 7238019, 7244118, 7252498, 7255555, 7258536, 7270538, 7303720, 7306454, 7306455, 7314367, 7320588, 7320589, 7320590, 7326049, 7344372, 7347684, 7364425, 7364426, 7370417, 7377768, 7381050, 7396226, 7407379, 7407380, 7410353, 7410354, 7413432, 7416402, 7438551, 7462030, 7462031, 7462314, 7465165, 7470122, 7507081, 7510392, 7513771, 7513772, 7517214, 7524183, 7527490, 7544056, 7547208, 7553150, 7559760, 7559762, 7565221, 7581944, 7611349, 7614869, 7614872, 7618253, 7658605, 7658606, 7671304, 7678320, 7686603, 7703188, 7713046, 7722351, 7731489, 7753676, 7766646, 7766647, 7775788, 7780433, 7780434, 7794228, 7802983, 7803306, 7806681, 7824163, 7845936, 7850442, 7874833, 7877163, 7891969, 7918660, 7918663, 7931455, 7963762, 7988445, 7998390, 8062025, 8066506, 8113812, 8142182, 8152513, 8167608, 8202082, 8206145, 8210842, 8241032, 8280544, 8282386, 8308475, 8308476, 8328546, 8353697, 8414285, 8425216, 8449287, 8465688, 8469687, 8475155, 8475158, 8480391, 8568133, 8690563, 8715547, 8753102, 8757998, 8758002, 8845321, 8899964, 8940202, 8985997, 9004906, 9028243, 9073246, 9186830, 9186833, 9227351, 9248593, 9272455, 9327436, D525592, RE38265, RE38396, RE38920, RE39935, RE40478, RE40952, RE41536E, RE41648E+ Pending.

© 2019 MOLD-MASTERS (2007) LIMITED. ALL RIGHTS RESERVED

Section 2 - Global Support

2.1 Manufacturing Facilities

GLOBAL HEADQUARTERS

CANADA

Mold-Masters (2007) Limited
233 Armstrong Avenue
Georgetown, Ontario
Canada L7G 4X5
tel: +1 905 877 0185
fax: +1 905 877 6979
canada@moldmasters.com

SOUTH AMERICAN HEADQUARTERS

BRAZIL

Mold-Masters do Brasil Ltda.
R. James Clerk Maxwell,
280 – Techno Park, Campinas
São Paulo, Brazil, 13069-380
tel: +55 19 3518 4040
brazil@moldmasters.com

UNITED KINGDOM & IRELAND

Mold-Masters (UK) Ltd
Netherwood Road
Rotherwas Ind. Est.
Hereford, HR2 6JU
United Kingdom
tel: +44 1432 265768
fax: +44 1432 263782
uk@moldmasters.com

EUROPEAN HEADQUARTERS

GERMANY / SWITZERLAND

Mold-Masters Europa GmbH
Postfach/P.O. Box 19 01 45
76503 Baden-Baden, Germany
Neumatttring 1
76532 Baden-Baden, Germany
tel: +49 7221 50990
fax: +49 7221 53093
germany@moldmasters.com

INDIA

Mold-Masters Technologies
Private Limited
247, Alagesan Road,
Shiv Building, Saibaba Colony.
Coimbatore T. N.
India 641 011
tel: +91 422 423 4888
fax: +91 422 423 4800
india@moldmasters.com

USA

Mold-Masters Injectioneering LLC
29111 Stephenson Highway
Madison Heights, MI 48071, USA
tel: +1 800 450 2270 (USA only)
tel: +1 (248) 544-5710
fax: +1 (248) 544-5712
usa@moldmasters.com

ASIAN HEADQUARTERS

CHINA/HONG KONG/TAIWAN

Mold-Masters (KunShan) Co, Ltd
Zhao Tian Rd
Lu Jia Town, KunShan City
Jiang Su Province
People's Republic of China
tel: +86 512 86162882
fax: +86 512-86162883
china@moldmasters.com

JAPAN

Mold-Masters K.K.
1-4-17 Kurikidai, Asaoku
Kawasaki, Kanagawa
Japan, 215-0032
tel: +81 44 986 2101
fax: +81 44 986 3145
japan@moldmasters.com

2.2 Regional Offices

AUSTRIA / East and South East Europe

Mold-Masters Handelsges.m.b.H.
Pyhrnstrasse 16
A-4553 Schlierbach
Austria
tel: +43 7582 51877
fax: +43 7582 51877 18
austria@moldmasters.com

ITALY

Mold-Masters Italia
Via Germania, 23
35010 Vigonza (PD)
Italy
tel: +39 049/5019955
fax: +39 049/5019951
italy@moldmasters.com

CZECH REPUBLIC

Mold-Masters Europa GmbH
Hlavni 823
75654 Zubri
Czech Republic
tel: +420 571 619 017
fax: +420 571 619 018
czech@moldmasters.com

KOREA

Mold-Masters Korea Ltd.
E dong, 2nd floor, 2625-6,
Jeongwang-dong, Siheung
City, Gyeonggi-do, 15117,
South Korea
Tel: +82-31-431-4756
korea@moldmasters.com

FRANCE

Mold-Masters France
ZI la Marinière,
2 Rue Bernard Palissy
91070 Bondoufle, France
tel: +33 (0) 1 78 05 40 20
fax: +33 (0) 1 78 05 40 30
france@moldmasters.com

MEXICO

Milacron Mexico Plastics Services
S.A. de C.V.
Circuito El Marques norte #55
Parque Industrial El Marques
El Marques, Queretaro C.P. 76246
Mexico
tel: +52 442 713 5661 (sales)
tel: +52 442 713 5664 (service)
mexico@moldmasters.com

Regional Offices - continued

POLAND

Mold-Masters Europa GmbH
Skr. Poczтовая 59
00-908 Warszawa
Poland
tel: +48 (0) 66 91 80 888
fax: +48 (0) 66 91 80 208
poland@moldmasters.com

SINGAPORE*

Mold-Masters Singapore PTE. Ltd.
No 48 Toh Guan Road East
#06-140 Enterprise Hub
Singapore 608586
Republic of Singapore
tel: +65 6261 7793
fax: +65 6261 8378
singapore@moldmasters.com
*Coverage includes Southeast
Asia, Australia, and New Zealand

SPAIN

Ferromatik Milacron /
Mold Masters Europa GmbH
C/. Enric Morera, 7
Polig. Ind. Foinvasa
08110 Montcada i Reixac
Barcelona, Spain
tel: +34 93 575 41 29
fax: +34 93 575 34 19
spain@moldmasters.com

TURKEY

Mold-Masters Europa GmbH
Merkezi Almanya Türkiye
İstanbul Şubesi
Alanaldı Caddesi Bahçelerarası
Sokak No: 31/1
34736 İçerenköy-Ataşehir
İstanbul, Turkey
tel: +90 216 577 32 44
fax: +90 216 577 32 45
turkey@moldmasters.com

2.3 International Representatives

ARGENTINA

Sollwert S.R.L.
tel: +54 11 4786 5978
e: sollwert@fibertel.com.ar

DENMARK*

Englmayer A/S
tel: +45 46 733847
e: support@englmayer.dk
*Coverage includes Norway and
Sweden.

BELARUS

HP Promcomplect
tel: +375 29
683-48-99 e:
info@mold.by

BULGARIA

Mold-Trade OOD
tel: +359 82 821 054
e: contact@mold-trade.com

ISRAEL

ASAF Industries
tel: +972 3 5581290
e: sales@asaf.com

FINLAND

Oy Scalar Ltd.
tel: +358 10 387 2955
e: info@scalar.fi

GREECE

Ionian Chemicals S.A.
tel: +30 210 6836918-9
e: m.pavlou@ionianchemicals.com

RUSSIA

System LLC
tel: +7 (495) 199-14-51
e: moldmasters@system.com.ru

PORTUGAL

Gecim LDA
tel: +351 244 575600
e: gecim@gecim.pt

ROMANIA

Tehnic Mold Trade SRL
tel: +4 021 230 60 51
e: contact@matritehightech.ro

SLOVENIA

RD Picta Tehnologije d.o.o.
tel: +386 59 969 117
e: info@picta.si

Section 3 - Safety

3.1 Introduction

Please be aware that the safety information provided by *Mold-Masters* does not absolve the integrator and employer from understanding and following international and local standards for safety of machinery. It is the responsibility of the end integrator to integrate the final system, provide necessary e-stop connections, safety interlocks and guarding, to choose the appropriate electrical cable for the region of use and to ensure compliance with all relevant standards.

It is the responsibility of the employer to:

- Properly train and instruct its personnel in the safe operation of equipment, including the use of all the safety devices.
- Provide its personnel with all necessary protective clothing, including such items as a face shield and heat resistant gloves.
- Ensure the original and continuing competence of personnel caring for, setting up, inspecting and maintaining injection molding equipment.
- Establish and follow a program of periodic and regular inspections of injection molding equipment to ensure it is in safe operating condition and proper adjustment.
- Ensure that no modifications, repairs or rebuild of portions are made to the equipment that reduces the level of safety existing at time of manufacture or remanufacture.

3.2 Safety Hazards



WARNING

Also refer to all machine manuals and local regulations and codes for safety information.

The following safety hazards are most commonly associated with injection molding equipment. See European Standard EN201 or American Standard ANSI/SPI B151.1.

Refer to the illustration of hazard areas below when reading the Safety Hazards Figure 3-1 on page 3-2.

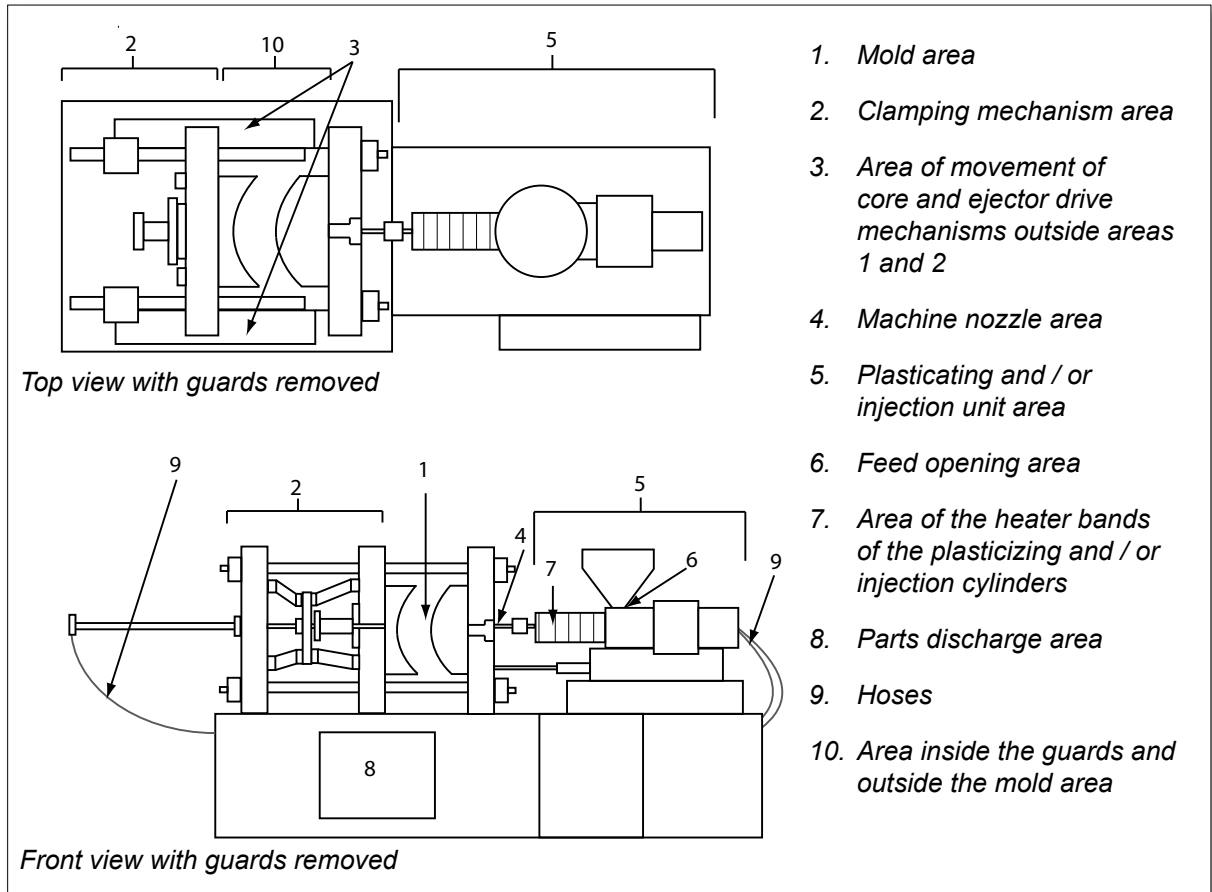

Figure 3-1 Injection molding machine hazard areas

Safety Hazards - continued

Table 3-1 Safety Hazards	
Hazard Area	Potential Hazards
<p>Mold Area Area between the platens. See Figure 3-1 area 1</p>	<p>Mechanical Hazards Crushing and / or shearing and / or impact hazards caused by:</p> <ul style="list-style-type: none"> • Movement of the platen. • Movements of the injection barrel(s) into the mold area. • Movements of cores and ejectors and their drive mechanisms. • Tie bar motion. <p>Thermal Hazards Burns and / or scalds due to operating temperature of:</p> <ul style="list-style-type: none"> • The mold heating elements. • Material released from/through the mold.
<p>Clamping Mechanism Area See Figure 3-1 area 2</p>	<p>Mechanical Hazards Crushing and / or shearing and / or impact hazards caused by:</p> <ul style="list-style-type: none"> • Movement of the platen. • Movement of the drive mechanism of the platen. • Movement of the core and ejector drive mechanism.
<p>Movement of Drive Mechanisms Outside the Mold Area and Outside the Clamping Mechanism Area See Figure 3-1 area 3</p>	<p>Mechanical Hazards Mechanical hazards of crushing, shearing and / or impact caused by the movements of:</p> <ul style="list-style-type: none"> • Core and ejector drive mechanisms.
<p>Nozzle Area The nozzle area is the area between the barrel and the sprue bushing. See Figure 3-1 area 4</p>	<p>Mechanical Hazards Crushing, shearing hazards and / or impact hazards caused by:</p> <ul style="list-style-type: none"> • Forward movement of the plasticizing and / or injection unit including nozzle. • Movements of parts of the power-operated nozzle shutoff and their drives. • Over pressurization in the nozzle. <p>Thermal Hazards Burns and or scalds due to operating temperature of:</p> <ul style="list-style-type: none"> • The nozzle. • Material discharging from the nozzle.
<p>Plasticizing and / or Injection Unit Area Area from the adapter / barrel head / end cap to the extruder motor above the sled including the carriage cylinders. See Figure 3-1 area 5</p>	<p>Mechanical Hazards Crushing, shearing and / or drawn-into hazards caused by:</p> <ul style="list-style-type: none"> • Unintentional gravity movements e.g. for machines with plasticizing and / or injection unit positioned above the mold area. • The movements of the screw and / or the injection plunger in the cylinder accessible through the feed opening. • Movement of the carriage unit. <p>Thermal Hazards Burns and / or scalds due to operating temperature of:</p> <ul style="list-style-type: none"> • The plasticizing and / or injection unit. • The heating elements e.g. heater bands. • The material and / or vapors discharging from the vent opening, feed throat or hopper. <p>Mechanical and/or Thermal Hazard</p> <ul style="list-style-type: none"> • Hazards due to reduction in mechanical strength of the plasticizing and / or injection cylinder due to overheating.
<p>Feed Opening See Figure 3-1 area 6</p>	<p>Pinching and crushing between injection screw movement and housing.</p>

Safety Hazards - continued

Table 3-1 Safety Hazards	
Hazard Area	Potential Hazards
Area of the Heater Bands of the Plasticizing and / or Injection Cylinders See Figure 3-1 area 7	Burns and / or scalds due to operating temperature of: <ul style="list-style-type: none"> • The plasticizing and / or injection unit. • The heating elements e.g. heater bands. • The material and / or vapors discharging from the vent opening, feed throat or hopper.
Parts Discharge Area See Figure 3-1 area 8	Mechanical Hazards Accessible Through the Discharge Area Crushing, shearing and / or impact hazards caused by: <ul style="list-style-type: none"> • Closing movement of the platen. • Movements of cores and ejectors and their drive mechanisms. Thermal Hazards Accessible through the discharge area Burns and or scalds due to operating temperature of: <ul style="list-style-type: none"> • The mold. • Heating elements of the mold. • Material released from / through the mold.
Hoses See Figure 3-1 area 9	<ul style="list-style-type: none"> • Whipping action caused by hose assembly failure. • Possible release of fluid under pressure that can cause injury. • Thermal hazards associated with hot fluid.
Area Inside the Guards and Outside the Mold Area See Figure 3-1 area 10	Crushing and / or shearing and / or impact hazards caused by: <ul style="list-style-type: none"> • Movement of the platen. • Movement of the drive mechanism of the platen. • Movement of the core and ejector drive mechanism. • Clamp opening movement.
Electrical Hazards	<ul style="list-style-type: none"> • Electrical or electromagnetic disturbance generated by the motor control unit. • Electrical or electromagnetic disturbance that can cause failures in the machine control systems and adjacent machine controls. • Electrical or electromagnetic disturbance generated by the motor control unit.
Hydraulic Accumulators	High pressure discharge.
Power Operated Gate	Crush or impact hazards caused by the movement of the power operated gates.
Vapors and Gases	Certain processing conditions and / or resins can cause hazardous fumes or vapors.



3.3 Operational Hazards

WARNINGS

- Refer to all machine manuals and local regulations and codes for safety information.
- The equipment supplied is subjected to high injection pressures and high temperatures. Ensure that extreme caution is observed in the operation and maintenance of the injection molding machines.
- Only fully trained personnel should operate or maintain equipment.
- Do not operate the equipment with unconfined long hair, loose clothing or jewelry, including name badges, neckties, etc. These may get caught in the equipment and can cause death or serious injury.
- Never disable or bypass a safety device.
- Ensure that the protective guards are placed around the nozzle to prevent the material from splashing or drooling.
- A burn hazard exists from material during routine purging. Wear heat-resistant personal protective equipment (PPE) to prevent burns from contact with hot surfaces or splatter of hot material and gases.
- Material purged from machine may be extremely hot. Ensure protective guards are in place around the nozzle to prevent material from splashing. Use proper personal protective equipment.
- It is highly recommended that all operators wear face shields and use heat resistant gloves when working around the feed inlet, purging the machine or cleaning the gates of the mold.
- Remove purged material from the machine immediately.
- Decomposing or burning material could result in noxious gases being emitted from the purged material, feed inlet or mold.
- Ensure proper ventilation and exhaust systems are in place to help prevent inhalation of harmful gases and vapors.
- Consult manufacturer's Material Safety Data Sheets (MSDS). Hoses fitted to the mold will contain high or low temperature fluids or air under high pressure. The operator must shut down and lockout these systems as well as relieving any pressure before performing any work with these hoses. Regularly inspect and replace all flexible hoses and restraints.
- Water and / or hydraulics on the mold may be in close proximity to electrical connections and equipment. Water leakage may cause an electrical short circuit. Hydraulic fluid leakage may cause a fire hazard. Always keep water and / or hydraulic hoses and fittings in good condition to avoid leaks. Never perform any work on the mold machine unless the hydraulic pump has been stopped.
- Check frequently for possible oil leaks / water leaks. Stop the machine and make repairs.
- Make sure that the cables are connected to the correct motors. Cables and motors are clearly labeled. Reversing the cables can result in unexpected and uncontrolled motion causing a safety risk or damage to the machine.



Operational Hazards - continued**WARNING**

- A crushing hazard exists between the nozzle and mold melt inlet during carriage forward motion.
- A possible shearing hazard exists between the edge of the injection guard and the injection housing during injection.
- The open feed port could present a hazard to a finger or a hand inserted during operation of the machine.
- The electric servo motors could overheat presenting a hot surface which could cause burns to someone touching it.
- The barrel, barrel head, nozzle, heater bands and mold components are hot surfaces which could result in burns.
- Keep flammable liquids or dust away from the hot surfaces as they could ignite.
- Follow good housekeeping procedures and keep floors clean to prevent slips, trips and falls due to spilled material on the work floor.
- Apply engineering controls or hearing conservation programs as necessary to control noise.
- When doing any work on the machine that requires moving and lifting the machine, ensure that lifting equipment (eyebolts, fork lift truck, cranes, etc.) will have sufficient capacity to handle mold, auxiliary injection unit or hot runner weight.
- Connect all lifting devices and support the machine using a crane of adequate capacity before commencing work. Failure to support the machine can result in severe injury or death.
- Mold cable from the controller to the mold must be removed before servicing the mold.

3.4 General Safety Symbols

Table 3-2 Typical Safety Symbols	
Symbol	General Description
	General – Warning Indicates an immediate or potentially hazardous situation, which if not avoided, could result in a serious injury or death, and / or damage to equipment.
	Warning – Barrel Cover Grounding Strap Lockout / tagout procedures must be followed before removing the barrel cover. Barrel cover can become energized upon removal of grounding straps and contact can result in death or serious injury. Grounding straps must be reconnected before reconnecting power to machine.
	Warning – Crushing and / or Impact Points Contact with moving parts can cause serious crushing injury. Always keep guards in place.
	Warning – Crush Hazard Closing Mold
	Warning – Hazardous Voltage Contact with hazardous voltages will cause death or serious injury. Turn off power and review electrical schematics before servicing equipment. May contain more than one live circuit. Test all circuits before handling to make sure circuits have been de-energized.
	Warning – High Pressure Overheated fluids may cause severe burns. Discharge pressure before disconnecting water lines.
	Warning – High Pressure Accumulator Sudden release of high pressure gas or oil can cause death or serious injury. Discharge all gas and hydraulic pressure before disconnecting or disassembling accumulator.
	Warning – Hot Surfaces Contact with exposed hot surfaces will cause serious burn injury. Wear protective gloves when working near these areas.
	Mandatory – Lockout / Tagout Ensure that all energies are properly locked out, and remain locked out until the service work is completed. Servicing equipment without disabling all internal and external power sources can cause death or serious injury. De-energize all internal and external power sources (electrical, hydraulic, pneumatic, kinetic, potential, and thermal).
	Warning – Molten Material Splashing Hazard Molten material or high pressure gas can cause death or severe burns. Wear personal protective equipment while servicing the feed throat, nozzle, mold areas and when purging the injection unit.
	Warning – Read Manual Before Operation Personnel should read and understand all instructions in the manuals before working on equipment. Only properly trained personnel should operate the equipment.
	Warning – Slip, Trip or Fall Hazard Do not climb on equipment surfaces. Serious slip, trip, or fall injuries can result from personnel climbing on equipment surfaces.

General Safety Symbols - continued

Table 3-2 Typical Safety Symbols	
Symbol	General Description
	Caution Failure to follow instructions may damage equipment.
	Important Indicates additional information or used as a reminder.

3.5 Wiring Check



CAUTION

System Mains Supply Wiring:

- Before connecting the system to a power supply, it is important to check that the wiring between the system and the power supply has been done correctly.
- Particular attention must be given to the current rating of the power supply. For example, if a controller is rated at 63A, then the power supply must also be rated at 63A.
- Check that the phases of power supply are wired correctly.

Controller to Mold Wiring:

- For separate power and thermocouple connections, ensure that the power cables are never connected to the thermocouple connectors and vice-versa.
- For mixed power and thermocouple connections, ensure that the power and thermocouple connections have not been wired incorrectly.

Communications Interface and Control Sequence:

- It is the customer's responsibility to verify functionality of any custom machine interface at safe speeds, prior to operating equipment in the production environment at full speed in automatic mode.
- It is the customer's responsibility to verify all required motion sequences are correct, prior to operating equipment in the production environment at full speed in automatic mode.
- Switching the machinery into Auto mode without having verified the control interlocks and motion sequence are correct, may cause damage to machinery and / or equipment.

Failure to do wiring or connections properly will result in equipment failure.

The use of *Mold-Masters* standard connections can help to eliminate the potential for wiring errors.

Mold-Masters Ltd. cannot be responsible for damage caused by customer wiring and / or connection errors.

3.6 Lockout Safety

WARNING

DO NOT enter the cabinet without first ISOLATING the supplies.

High voltage and amperage cables are connected to the controller and the mold. There is also a high voltage cable connection between the servo motor and the controller. Electrical power must be shut off and lockout / tagout procedures followed prior to installing or removing any cables.

Use lockout / tagout to prevent operation during maintenance.

All maintenance should be performed by properly trained personnel based on local laws and regulation. Electrical products may not be grounded when removed from the assembled or normal operating condition.

Ensure proper grounding of all electrical components before performing any maintenance to avoid potential risk of electrical shock.

Often power sources are inadvertently turned on or valves are opened mistakenly before maintenance work is completed, resulting in serious injuries and fatalities. Therefore, it is important to ensure that all energies are properly locked out and that they remain locked out until the work is completed.

If a lockout is not performed, uncontrolled energies could cause:

- Electrocutation from contact with live circuits
- Cuts, bruises, crushing, amputations or death, resulting from entanglement with belts, chains, conveyors, rollers, shafts, impellers
- Burns from contact with hot parts, materials or equipment such as furnaces
- Fires and explosions
- Chemical exposures from gases or liquids released from pipelines



3.7 Electrical Lockout

WARNING - READ MANUAL

Refer to all machine manuals and local regulations and codes.

NOTE

In some instances, there may be more than one power source feeding equipment and steps must be taken to ensure that all sources are effectively locked out.

Employers must provide an effective lockout / tagout program.

1. Shut down machine using normal operational shutdown procedure and controls. This should be done by, or in consultation with the machine operator.
2. After ensuring that the machinery has been completely shut down, and all controls in the “off” position, open the main disconnect switch located in the field.
3. Using your own personal padlock, or one assigned by your supervisor, lock the disconnect switch in the off position. Do not lock only the box. Remove the key and retain. Complete a lockout tag and affix to the disconnect switch. Each person working on the equipment must follow this step. The lock of the person doing the work or in charge must be installed first, remain throughout and be removed last. Test the main disconnect switch and make sure it cannot be moved to the “on” position.
4. Try to start the machine using the normal operation controls and point of operation switches to make sure that the power has been disconnected.
5. Other sources of energy that could create a hazard while working on the equipment must also be de-energized and appropriately “locked-out”. This can include gravity, compressed air, hydraulics, steam and other pressurized or hazardous liquids and gases. See Table 3-3.
6. When the work is completed, prior to removing the last lock, make sure the operational controls are in the “off” position so that the main disconnect switching is done under “no load”. Ensure all blocks, tools and other foreign materials are removed from machine. Also ensure that all personnel that may be affected are informed that the lock(s) will be removed.
7. Remove lock and tag, and close the main disconnect switch if permission has been given.
8. When the work has not been completed on the first shift, the next operator should install a personal lock and tag before the first operator removes the original lock and tag. If the next operator is delayed, a lock and tag could be installed by the next supervisor. Lockout procedures should indicate how the transfer is to be conducted.
9. It is important that, for their personal protection, each worker and/or foreperson working in or on a machine places his/her own safety lock on the disconnect switch. Use tags to spotlight work in progress and give details of work being done. Only when the work is completed and the work permit signed off, may each worker remove his/her lock. The last lock to be removed should be that of the person supervising the lockout and this responsibility should not be delegated.

© Industrial Accident Prevention Association, 2008.

3.7.1 Energy Forms and Lockout Guidelines

Table 3-3 Energy Forms, Energy Sources and General Lockout Guidelines		
Energy Form	Energy Source	Lockout Guidelines
Electrical Energy	<ul style="list-style-type: none"> • Power transmission lines • Machine power cords • Motors • Solenoids • Capacitors (stored electrical energy) 	<ul style="list-style-type: none"> • Turn off power at machine first (i.e., at point of operation switch), and then at the main disconnect switch for the machine. • Lock and tag the main disconnect switch. • Fully discharge all capacitive systems (e.g., cycle machine to drain power from capacitors) according to the manufacturer's instructions.
Hydraulic Energy	<ul style="list-style-type: none"> • Hydraulic systems (e.g., hydraulic presses, rams, cylinders, hammers) 	<ul style="list-style-type: none"> • Shut off, lock (with chains, built-in lockout devices, or lockout attachments) and tag valves. • Bleed off and blank lines as necessary.
Pneumatic Energy	<ul style="list-style-type: none"> • Pneumatic systems (e.g., lines, pressure reservoirs, accumulators, air surge tanks, rams, cylinders) 	<ul style="list-style-type: none"> • Shut off, lock (with chains, built-in lockout devices, or lockout attachments) and tag valves. • Bleed off excess air. • If pressure cannot be relieved, block any possible movement of machinery.
Kinetic Energy (Energy of a moving object or materials. Moving object may be powered or coasting)	<ul style="list-style-type: none"> • Blades • Flywheels • Materials in supply lines 	<ul style="list-style-type: none"> • Stop and block machine parts (e.g. stop flywheels and ensure that they do not recycle). • Review entire cycle of mechanical motion, ensure that all motions are stopped. • Block material from moving into area of work. • Blank as necessary.
Potential Energy (Stored energy that an object has the potential to release due to its position)	<ul style="list-style-type: none"> • Springs (e.g., in air brake cylinders) • Actuators • Counterweights • Raised loads • Top or movable part of a press or lifting device 	<ul style="list-style-type: none"> • If possible, lower all suspended parts and loads to the lowest (rest) position. • Block parts that might be moved by gravity. • Release or block spring energy.
Thermal Energy	<ul style="list-style-type: none"> • Supply lines • Storage tanks and vessels 	<ul style="list-style-type: none"> • Shut off, lock (with chains, built-in lockout devices, or lockout attachments) and tag valves. • Bleed off excess liquids or gases. • Blank lines as necessary.

3.8 Disposal



WARNING

Milacron *Mold-Masters* declines any responsibility for personal injury or personal damage arising from reuse of the individual components, if these parts are used other than for the original and proper intended purpose.

1. Hot runner and system components must be disconnected from the power supply fully and properly before disposal, including electricity, hydraulics, pneumatics and cooling.
2. Ensure that the system to be disposed of is free from fluids. In the case of hydraulic needle valve systems, drain the oil from the lines and cylinders and dispose it in an environmentally responsible manner.
3. The electrical components are to be dismantled, separating them accordingly as environmentally-friendly waste or disposed as hazardous waste if necessary.
4. Remove the wiring. The electronic components are to be disposed in accordance with the national electric scrap ordinance.
5. The metal parts are to be returned for metal recycling (waste metal and scrap trade). The instructions of the corresponding waste disposal company are to be observed in this case.

Recycling of all possible materials should be at the forefront of the disposal process.

3.9 MT/MT2 Controller User Hazards



WARNING - ELECTRIC SHOCK HAZARD

Most controller warnings pertain to electrical hazards. It is crucial to comply with these warnings to minimize any personal danger.

- Ensure that all energies are properly locked out in the controller and mold machine before installation of the controller into the system.
- DO NOT enter the cabinet without first ISOLATING the supplies. There are unguarded terminals inside the cabinet which may have a dangerous potential across them. Where a three-phase supply is used, this potential may be up to 415VAC.
- Voltage and amperage cables are connected to the controller and the mold. Electric power must be shut off and lockout / tagout procedures followed prior to installing or removing any cables.
- Integration should be done by properly trained personnel based on local codes and regulations. Electrical products may not be grounded when removed from the assembled or normal operating condition.
- Do not mix electrical power cables with thermocouple extension cables. They are not designed to carry the power load or list accurate temperature readings in each other's application.
- The main power switch is found at the lower rear of the controller. It is sufficiently rated to handle the total load current during switch on and switch off.
- The main power switch can be locked using a padlock applied under the lockout / tagout procedure found in "Table 3-3 Energy Forms, Energy Sources and General Lockout Guidelines" on page 3-11.
- Use lockout / tagout to prevent operation during maintenance.
- All maintenance should be performed by properly trained personnel based on local laws and regulation. Electrical products may not be grounded when removed from the assembled or normal operating condition.
- Ensure proper grounding of all electrical components before performing any maintenance to avoid potential risk of electrical shock.



WARNING

The display console and controller cabinet together are designed for use in the plastic injection molding industry as temperature controllers for third party hot runner systems as commonly used in mold tools. They must not be used in residential, commercial or light-industrial environments. Furthermore, they must not be used in an explosive atmosphere, or where there is a possibility of such an atmosphere developing.

The controller cabinet and touchscreen console should be installed in a clean dry environment where the ambient conditions do not exceed the following limits:

- Temperature +5 to +45°C
- Relative Humidity 90% (non-condensing)

Section 4 - Overview



NOTE

The MT and MT-02-02 controllers both operate in the same way, although their displays can be different. This manual will use MT to refer to both controllers, and it will specifically note if there is a difference between the two controllers.



Figure 4-1 MT controller



Figure 4-2 MT2 controller

4.1 Specification

The following are general specifications. The actual controller / console supplied may have contractual variations and differ in some specified options.

Table 4-1 General Specifications	
Supply Voltage	95-265VAC 3 phase-to-neutral 50Hz with neutral, others available 220/60Hz Delta
Unit Overload Protection	Miniature circuit breaker
Output Overload Protection	15A super-quick acting (FF) fuse on both legs
Power Output	15A/3000W per zone
Ground Fault Detection	20mA per zone
Thermocouple Input	Iron Constantan Fe/Con type 'J', or type 'K'
Control Algorithm	Self tuning PID
Soft-Start with Auto Tune	Unique low voltage method for heater safety
Temperature Scale	Celsius (Centigrade) or Fahrenheit
Operating Range	0 - 472°C or 32 - 882°F
Control Accuracy	+/-1°F
Alarm Output	Closing volt-free contacts - 2A max 125VAC or 60VDC
Interface	2 inches full color LCD touchscreen
Case Details	Heavy duty metal cabinet

4.2 TMXL/MT Compatibility



WARNING

DO NOT put TMXL cards into an MT case. Although the cards appear interchangeable, putting a TMXL card into an MT case would leave the output circuit unprotected because there would be no output fuse.

It is safe to put an MT cards into a TMXL case because the output circuits would be protected with output fuses on the card and under the case lid.



NOTE

This section is not applicable for the MT-02-02 controller.

The MT Series controller has been designed to give some interchangeability with its predecessor the TMXL2. It is built to the same size and fits into a similar cabinet.

There is one major physical change: the main zone fuses have been moved from under the cabinet lid on the TMXL2 to “on-the-card” for the MT. This change means that individual cards can be pulled out to safely access and change any ruptured output fuse.

In the TMXL2, output fuses were located under the cover, which meant the system had to be shutdown to gain safe access to replace a ruptured fuse.

4.3 Tool Connections

The various connections to the system using the cables supplied with the equipment are specified in “Section 9 - Wiring Details”

4.4 Controller Power Supplies

The control cabinet can be manufactured to accept a wide range of supplies and sequence of phases. Refer to the serial plate in the controller cabinet for confirmation of the supply requirements. If the local supply is outside the specified range, please contact “Section 2 - Global Support” on page 2-1

4.5 Filter Option

In countries where noise across power lines is a concern, *Mold-Masters* recommends that you fit the model 63AYC10B in-line filter which is supplied by TC Connectivity.

4.6 Switch On and Off

The main power switch is a rotary switch found at the front of the controller. It is sufficiently rated to disconnect the total load current during switch on and switch off.

4.6.1 Switch On

When the controller is switched on, all zones go into “Run” mode and the tool starts to heat automatically.



4.6.2 Switch Off Individual Modules

Each module has its own power switch. Use the button below the screen to turn the module off and on.

4.6.3 Switch Off the Whole Controller

When the power to the whole controller is switched off, all zone settings are memorized. If different zones have been set to different temperatures to get optimum performance, then the controller will use those settings the next time it is switched on.

4.6.4 Switch Off Individual Zones

1. To switch off any single zone choose that zone to show the initial menu.



2. Choose [⏻] to switch off that zone.



3. See that zone now displays “OFF”. Repeat the same steps to switch back on again.



4.7 Controller Cabinet

For MT Series Controller:

The power supply to the control cabinet is via a strain relief cable gland plug wired in either 5-wire star or 4-wire delta configuration. Please check your specifications for details of which supply configuration has been used.

Connections to the tool as standard are either by a mixed power and thermocouple cable, or individual power cable(s) and individual thermocouple cable(s).

Mold-Masters standard wiring details are shown in “Section 9 - Wiring Details”.

For MT-02-02 Controller:

The power supply to the control cabinet is via a strain relief cable gland plug provided for single phase configuration. A mains connector should be fitted that is suitable for the region where the controller is used. Connection to the tool is made with a non-detachable loom fitted with a Harting HAN10E connector.

Typical wiring details are shown in “Section 9 - Wiring Details”.

An alarm output option is available for extending the alarm or for inhibiting the injection process.

4.7.1 Controller Modules

The controller is dual-zone modular unit that provides real time temperature control.

Each card has three main components:

- thermocouple input circuits
- CPU
- multi-voltage output triacs

Thermocouple Inputs

The thermocouple inputs have preset responses for both J and K- type thermocouples. The selection of sensor type can be done in the Program menu. The selection of sensor type will set the CPU linearization to match the selected thermocouple type.



NOTE

As a standard, type J thermocouple cables are supplied. It is advised to request type K thermocouple cables if your application uses a type K thermocouple.

Central Processor Unit (CPU)

The CPU provides the following facilities:

- closed and open loop control of the zones
- processes thermocouple and current readings to show on display
- checks for alarm conditions, including excess current, incorrect thermocouple wiring, zone over temperature condition, low impedance between heater and ground and generates alarm information for the display screen and alarm relay
- controls the output power to the on-board triac using a number of self-tuning algorithms

The card requires no analogue calibration and is ready for use once set up from the display console.

Output Triacs

The controller card has a pair of on-board triacs that are capable of controlling heating loads of up to 16 Amps peak.

4.8 How the MT Controller Works

Mold-Masters controllers are designed to perform in closed and open loop configurations. We consider that the normal operating mode is closed loop. This is illustrated in the following diagram and explained below.

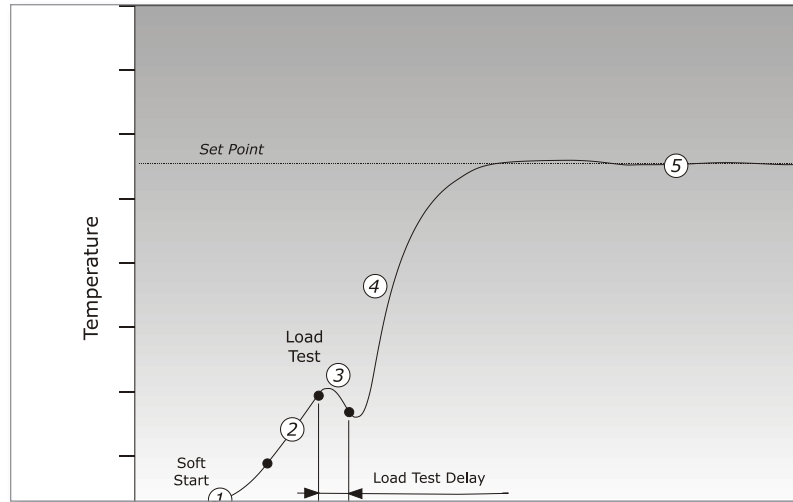

The zone controller slowly ramps up the heater power and simultaneously looks for a positive temperature change at the thermocouple input. The controller verifies the actual rate of rise against a predetermined value in program parameter r1. Power is slowly increased until the correct rate of rise is achieved.

At ramp temperature rE, the dwell time rt is activated (2 minutes), this permits any residual moisture in the heating elements to be eliminated. After all zones reached to ramp temperature, they will start heating up together again.

The controller continues to ramp up the temperature to the set point with the speed set in program parameter r2, which should be achieved with minimum overshoot.

Having built a virtual model to map the tool and heater characteristics, the controller can maintain the temperature at an accurate point with virtually no deviation.

4.8.1 Set the Ramp Feature (On / Off)

Normally the controller starts to heat a zone and then it pauses at around 120° C for two minutes to dry out any damp that may be present.

If you prefer not to wait for this dwell period then you can use the “Ramp” feature to skip the delay period to reach molding temperature more quickly. See page 5-9 for full description.

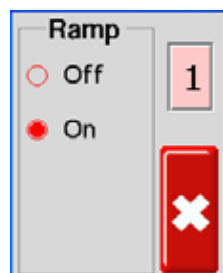

4.9 Program Menus

Select [Program] from the Function menu to reveal further setup options. The [↑] and [↓] buttons allow you to view the various options seen in the diagrams below.

A more complete description of these various parameters is given further on in this user manual in “Section 5 - Setup” on page 5-1 and in “Section 6 - Operation” on page 6-1.

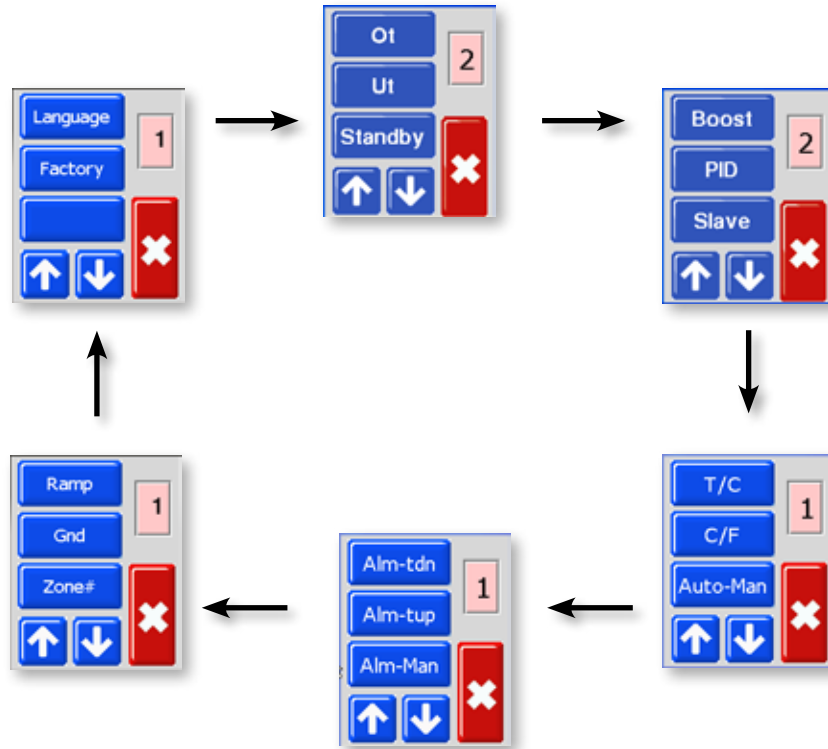

Figure 4-3 MT Menu

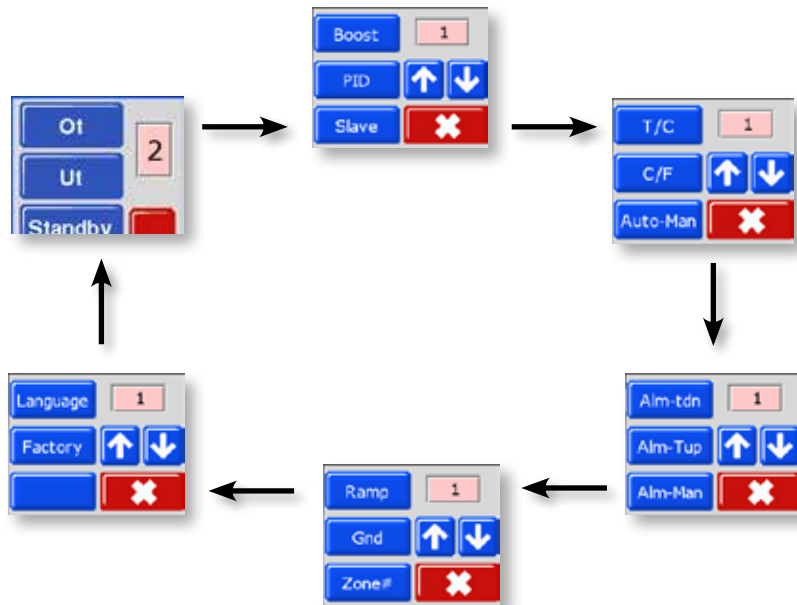

Figure 4-4 MT2 Menu

Section 5 - Setup



WARNING

Ensure that you have fully read “Section 3 - Safety” before connecting or operating the controller.

It is the responsibility of the integrator to understand and follow international and local standards for safety of machinery when integrating the controller with the molding system.

The MT controller should be located in such a way that the main disconnect is easily accessible in case of emergency.

MT Series controllers are shipped with a power cable, which is a correct size to run the system. When you install a connector on the cable, ensure that the connector can safely withstand the full system load.

The MT controller supply should have a fused disconnect or main circuit breaker according to local safety codes. Refer to the serial plate on the controller cabinet for confirmation of the main supply requirements. If the local supply is outside the specified range, please contact *Mold-Masters* for advice.



WARNING - ELECTRIC SHOCK HAZARD

It is crucial to comply with these warnings to minimize any personal danger.

- Ensure that all energies are properly locked out in the controller and mold machine before installation of the controller into the system.
- DO NOT enter the cabinet without first ISOLATING the supplies. There are unguarded terminals inside the cabinet which may have a dangerous potential across them. Where a three-phase supply is used, this potential may be up to 415VAC.
- Voltage and amperage cables are connected to the controller and the mold. Electric power must be shut off and lockout / tagout procedures followed prior to installing or removing any cables.
- Integration should be done by properly trained personnel based on local codes and regulations. Electrical products may not be grounded when removed from the assembled or normal operating condition.
- Do not mix electrical power cables with thermocouple extension cables. They are not designed to carry the power load or list accurate temperature readings in each other’s application.



WARNING - TRIP HAZARD

The integrator should ensure that the controller cables do not present a trip hazard on the floor between the controller and the mold machine.

5.1 Introduction

New MT Series controllers leave the factory with their default settings which are shown in this table:

Table 5-1 Factory Settings	
Zone Temperature	260°C or 500°F
Standby Level	100°C or 180°F
Boost Level	75°C or 135°F
Over temperature Range	10°C or 18°F
Under temperature Range	
Ramp	On
Auto-Man	On
Extended Alarms for Manual, Standby and Boost	Off

This section of the manual has procedures to change default settings to your preferred values and also how to save these new values.

It is possible to restore the default settings at any time.

See “Restore Factory Settings and Recalibration” on page 7-2.

5.2 Set Zone Numbering



NOTE

This section is not applicable for the MT-02-02 controller.

For MT controllers that have two or more modules, the user is able to number the higher zones in a logical sequence.

See below for an example of an MT-06-06 system:



1. From the Temperature Display screen, choose either zone to obtain the initial menu.



2. Choose [**X**] to obtain the Function menu.



3. Choose [**Program**] to obtain the Program menu.



Set Zone Numbering - continued

4. Choose [↑] or [↓] to find the page containing a Zone# option.

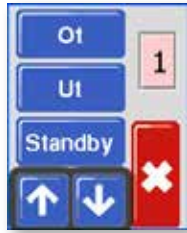

5. Choose [Zone#] to open the zone numbering option.



6. Use [↑] or [↓] to set the required zone number.



7. Choose [✕] twice to return to the main display.



5.3 Set the Temperature Scale

The MT controller can show temperature in Fahrenheit or Celsius. Changes in this parameter apply to both zones of the controller card.

1. From the Temperature Display screen, choose either zone to obtain the initial menu.





2. Choose [] to obtain the Function menu.



3. Choose [**Program**] to obtain the Program menu.



4. Choose [] or [] to find the page containing a C/F option.



5. Choose [**C/F**] to open the Temperature Scale option.



Set the Temperature Scale - continued

6. Select either [C] or [F] to suit the local operating preference.

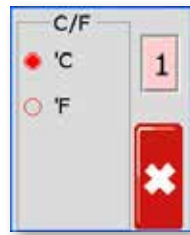

7. Choose [*****] twice to return to the main display.
The main display is now in Celsius.



5.4 Change Zone PID Characteristics

On initial startup, each module CPU reads the zone heater characteristic and determines an appropriate PID curve for that zone. It is possible for the user to override this setting and change the zone response time for any zone.

In general, a small nozzle works best on a “Fast” setting, a larger manifold uses a “Med(ium)” setting and a really large heating platen may require a “Slow” setting. If you are having problems matching a zone then consult your local dealer for service advice.

Once the controller has run and the PID curve has been selected, the screen will display the selected speed with a blue ring. See step five in the following procedure to see an example of this blue ring.

1. From the Temperature Display screen, choose either zone to obtain the initial menu.





2. Choose [>] to obtain the Function menu.



3. Choose [**Program**] to obtain the Program menu.



4. Choose [>] or [>] to find the page containing the PID option.



Change Zone PID Characteristics - continued

5. Choose [PID] and select an alternative timing.

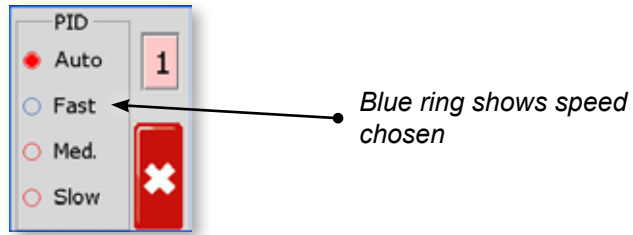

6. Choose [✖] twice to return to the main display. The system is now set to run at the chosen speed.



5.5 Set the Ramp Feature

Normally the controller starts to heat a zone and then it pauses at around 120°C for two minutes to dry out any damp that may be present. See “4.8 How the MT Controller Works” on page 4-6 for more information.

To reach molding temperature more quickly, the user can skip this dwell period with the “Ramp” feature.

The default setting is Ramp on, which follows the normal delay period.

1. From the Temperature Display screen, choose either zone to obtain the initial menu.





2. Choose [] to obtain the Function menu.



3. Choose [**Program**] to obtain the Program menu.



4. Choose [] or [] to find the page containing the Ramp option.



Set the Ramp Feature - continued

5. Choose [Ramp] and set it to Off.



6. Choose [x] twice to return to the main display.



5.6 Set Boost Value

Before you can use the Boost function, you must first configure the Boost value. The Boost settings made here are only for Boost temperature and are individually set for each zone.

The Boost period is set at two minutes and is not configurable.

When Boost is activated, the controller will raise the zone temperature.



NOTE

If a high Boost temperature is chosen for a zone set to a slow speed, the zone may not have enough time to reach the set Boost temperature before the Boost period is finished.

The default or factory Boost setting is 75°C or 135°F. If your controller is set in Celsius at 200°C, temperature will raise to 275°C. If your controller is set in Fahrenheit at 400°F, temperature will boost up to 535°F.

1. From the Temperature Display screen, choose either zone to obtain the initial menu.



2. Choose [] to obtain the Function menu.



3. Choose [**Program**] to obtain the Program menu.



Set Boost Value - Continued

4. Choose [↑] or [↓] to find the page containing a Boost option. Choose [Boost] to open the value setting option.



5. Use [↑] or [↓] to set the desired Boost temperature.

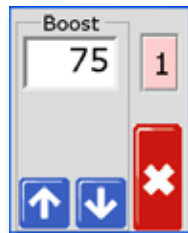

6. Choose [X] twice to return to the main display.

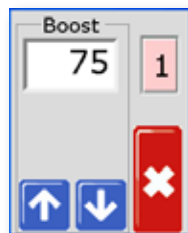

5.7 Set Standby Value

Before the Standby function can be activated, the user must first configure the settings. The values set with this procedure are only for Standby temperature and must be individually set for every zone. When Standby is activated, those zones with any Standby value configured will reduce their temperature.

The default or factory Standby setting is 100°C or 180°F. If your controller is set in Celsius at 300°C, temperature will lower to 200°C. If your controller is set in Fahrenheit at 580°F, temperature will lower to 400°F.

1. From the Temperature Display screen, choose either zone to obtain the initial menu.



2. Choose [**X**] to obtain the Function menu.



3. Choose [**Program**] to obtain the Program menu.



4. Choose [**↑**] or [**↓**] to find the page containing a Standby option. Choose the [**Standby**] button to open the value setting option.



Set Standby Value - continued

5. Use [↑] or [↓] to set the desired Standby temperature.
You can hold the [↑] or [↓] buttons down to raise or lower value by large amounts.



6. Choose [X] twice to return to the main display.



5.8 Monitor Temperature Limits

The controller card monitors the actual temperature of each zone and verifies that the zone is operating within specific limits. Rather than fixed points of temperature, the Over Temperature (Ot) and Under Temperature (Ut) limits are set as deviation above or below the set point. If these temperatures are exceeded, the alarm relay on the MT card changes state to raise a disable injection interlock or alarm.

5.8.1 Warning and Alarm Limits

Although there is only one upper and one lower alarm setting, each gives a visual warning at halfway point. If an upper alarm is set to 10 degrees, then a warning will show at 5 degrees. The same holds true for the Under Temperature alarm level.

1. From the Temperature Display screen, choose either zone to obtain the initial menu.



2. Choose [**X**] to obtain the Function menu.



3. Choose [**Program**] to obtain the Program menu.



4. Choose [**Ot**] to open the value setting option.



Warning and Alarm Limits - continued

- Use [↑] or [↓] to set the desired Over Temperature limit.
You can hold the [↑] or [↓] buttons down to raise or lower value by large amounts.



- Choose [✖] to return then [Ut] to open the Under Temperature limit.
Use [↑] or [↓] to set the desired Under Temperature limit.



- Choose [✖] twice to return to the main display.



5.9 Set Ground Fault Detection

The default setting is “On” where the card will start to decrease power if it detects more than 20 mA leakage current. If it detects an earth leakage of 40 mA or more then it reduces output to zero.

If the option is set to “Off” then the zone will continue to deliver normal power.

1. From the Temperature Display screen, choose either zone to obtain the initial menu.



2. Choose [✖] to obtain the Function menu.



3. Choose [Program] to obtain the Program menu.



4. Choose [↑] or [↓] to find the page containing the Ground selection option.



Set Ground Fault Detection - continued

5. Choose [**Gnd**] to open the page and set it to On or Off as required.



6. Choose [**X**] twice to return to the main display.



5.10 Set Mold Leak Detection

A zone that starts to require a higher power level to maintain a set temperature may have a fault condition. Plastic melt leaking away from the nozzle is the most common cause of this issue. The system will require more power to heat the extra plastic which may be leaking into the mold or runner system.

The user can use the leak detection function that will cause the unit to trigger an alarm output and visual signal if extra power usage occurs above a set level. The unit will make the common outgoing alarm sound, and the visual signal is indicated in the zone window. The display will be red rather than the normal yellow color.

From the Temperature Display screen, choose either zone to obtain the initial menu.



1. Choose [**X**] to obtain the Function menu.



2. Choose [**Program**] to obtain the Program menu.



3. Choose [**↑**] or [**↓**] to find the page containing the Leak option.



Set Mold Leak Detection - continued

4. Choose [**Leak**] to open the page then choose [**↑**] or [**↓**] to set the Leak detection power level.

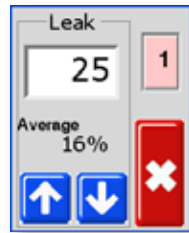

5. Choose [**X**] twice to return to the main display.



5.11 Set Response to Thermocouple Failure

Choose a response for any zone that detects a failed thermocouple.

Normal (Auto-Man OFF) – No action corrective taken. The zone power sets down to 0% and it shows a T/C fatal alarm.

Auto Manual (Auto-Man ON)- The zone has sufficient data, after 10 minutes steady running, to switch to Manual mode at a power level that should hold the previous temperature.

1. From the Temperature Display screen, choose either zone to obtain the initial menu.



2. Choose [] to obtain the Function menu.



3. Choose [**Program**] to obtain the Program menu.



4. Choose [] or [] to find the page containing the Auto-Man option.



Set Response to Thermocouple Failure - continued

5. Choose [**Auto-man**] to open the page and set it to On.



6. Choose [**X**] twice to return to the main display.



5.12 Restrict Access to Manual, Standby or Boost

It is possible to stop a user from selecting the Manual Control, Standby or Boost functions.

From the Temperature Display Screen, choose either zone to obtain the initial menu.



1. Choose [] to obtain the Function menu.



2. Choose [**Program**] to obtain the Program menu.



3. Choose [] or [] to find the page containing a [**Factory**] option.



4. Enter the password and then choose [] to access the next screen.



Restrict Access to Manual, Standby or Boost - continued

5. Check the M.Dis box.



6. Choose [~~X~~] to return to the main display.



7. To check this setting, choose [~~X~~] and [Program] to see these user function buttons greyed out and no longer functional.
8. To reset return to the Factory box and uncheck M.Dis.



NOTE

Selecting this option will inhibit the front panel rocker switch so that Standby or Boost selection will also be ineffective.

5.13 Extend Alarms for Manual, Standby or Boost Operation

There are three conditions which may be selected to generate external alarm conditions. These options are available to give an outgoing (closing) signal if the controller is set to Manual (Alm-Man), Standby (Alm-tdn) or Boost (Alm-tup).

Their default condition is “Off” but they may be changed to “On,” in which case activating Manual, Standby or Boost may generate an alarm output.

1. From the Temperature Display screen, choose either zone to obtain the initial menu.



2. Choose [**X**] to obtain the Function menu.



3. Choose [**Program**] to obtain the Program menu.



4. Choose [**↑**] or [**↓**] to find the page containing the Alarm option.



Extend Alarms for Manual, Standby or Boost Operation - continued

5. Choose any of the three options ([Alm-tdn] shown here) to open the page and set it to On.



6. Choose [**X**] once to return to the Alarm selection in order to select more Alarm options.



7. Choose [**X**] a second time to return to the main display.



5.14 Language

There are four language options available for the MT controller. To select a language, follow the procedure below:

1. From the Temperature Display screen, choose either zone to obtain the initial menu.



2. Choose [**X**] to obtain the Function menu.



3. Choose [**Program**] to obtain the Program menu.



4. Choose [**↑**] or [**↓**] to find the page containing the Language option.



5. Choose [**Language**] to open the page and set it to the required language.



Language - continued

- Choose [**x**] twice to return to the main display.



5.15 Set the Required Zone Temperatures

Once all user options have been set, the normal operating temperatures need to be set.

- From the main display choose the zone for which the temperature needs to be set.



- Use [**↑**] or [**↓**] to adjust the set temperature.
You can hold the [**↑**] or [**↓**] buttons down to raise or lower value by large amounts.



- Choose [**x**] to return to the main display.
Repeat for other zones.



Section 6 - Operation



WARNING

Ensure that you have fully read “Section 3 - Safety” before operating the controller.

Operation is concerned with everyday use of the controller for normal production use, for example, selecting an appropriate run mode for the machine according to whether the tool is working or waiting.

It may also be necessary to make changes to the heater temperatures and to use the graphical display of recent performance, which may help such decisions.

6.1 Run Mode

1. Controller here shows one zone turned OFF.



2. Choose that zone, and then choose [⏻] to start.



3. Choose [✱] to return to main screen and see zone 1 now in Auto-Run mode.

Repeat these steps for the other zone if needed.



6.2 OFF Mode (Single Zone)

1. Each card controls two zones at a time, and each zone can be turned off individually.



2. Choose either zone and then choose [⏻] to stop.



3. Choose [✖] to return to main screen and see zone 1 is now in OFF mode. Repeat these steps for the other zone if needed.



6.3 Off Mode (Single Module)



NOTE

This section is not applicable for the MT-02-02 controller.

1. Turn the module off by choosing the [⏻] button on the front of the individual card.



6.4 Manual Mode

Manual mode (open loop working) can be simply selected as an alternative to running in Auto mode (closed loop).

If the screen at step three shows the Manual, Standby and Boost buttons greyed out then this function has been inhibited. See “5.12 Restrict Access to Manual, Standby or Boost”.

1. From the Temperature Display screen, choose either zone to obtain the initial menu.



2. Choose [] to obtain the Function menu.



3. Choose [**Manual**] to enter Manual mode and go to open loop working.



4. Choose [] to return to main display and see that zone 1 is now running in Manual mode.



6.5 Manual Mode - Power Level

1. Choose the Manual zone to obtain the initial menu.



2. Choose [↑] to raise or [↓] to lower the power setting and consequently the temperature.



6.6 Slave Mode

Slave mode is an alternative to Manual mode and can be selected if a zone has a faulty thermocouple. The slaved zone then mimics the same power output as the healthy zone. If both zones were running at a similar power level previously, then the slaved zone will hold a similar temperature.



NOTE

Slave mode can only be used between two control zones on the same module and not across different modules.

1. From the Temperature Display Screen, choose either zone to obtain the initial menu.



2. Choose [] to obtain the Function menu.



3. Choose [**Program**] and use [] or [] to find Slave.



4. Choose [**Slave**].



Slave Mode - continued

5. Choose Slave [On].



6. Choose [**X**] twice to return to main display, and see that zone 1 displays "S2" to indicate it is slaved to zone 2.



7. To restore to Auto mode, repeat the first five above steps and select Slave [Off].



6.7 Standby and Boost Mode



NOTE

This section is not applicable for the MT-02-02 controller.

There are two options for switching to Standby or Boost mode.

1. You can set each zone individually by using the module touchscreens.
2. Alternatively you can switch all zones together by using the cabinet Boost/Normal/Standby selector shown below.



6.7.1 Standby – Whole Cabinet

Switch the Boost/Normal/Standby selector towards the right and select Standby. All zones are set down by the standby amount and remain at that lower temperature until the switch is restored to the center off position.

6.7.2 Boost – Whole Cabinet

Switch the Boost/Normal/Standby selector towards the left and select Boost. All zones are raised by the Boost amount for a set period of two minutes. Boost function will stop after two minutes, even if the switch stays in the Boost position.

6.7.3 No Standby or Boost Option

Note that if the factory setting has been set to Manual Disable, then the Standby/Boost rocker switch will have no effect on controller temperature. If you suspect it may have been set, choose any zone and then choose [✘] to obtain the Function menu. If the three buttons are greyed out, as shown in the picture below, then Standby and Boost are not available.



6.8 Standby Mode – Individual Zones

This mode is used when the mold tool is paused. All zone temperatures will be reduced by a preset amount, to prevent degradation of materials. To set the temperature reduction, see “Setting Standby Level” on page 5-13.

Once Standby mode is activated, both zones will be reduced to Standby temperature.

1. From the Temperature Display screen, choose either zone to obtain the initial menu.



2. Choose [] to obtain the Function menu.



3. Choose [**Program**] to obtain the Program menu.
Choose [**Standby**] to enter Standby mode and reduce zone temperatures.



NOTE

If the screen in this step shows the Manual, Standby and Boost buttons greyed out then this function has been inhibited. See page 5-23 for more information.

Standby Mode – Individual Zones - continued

- The screen reverts to main display.
The Standby temperature and confirmation message “tdn” will flash alternately in the Actual Temperature window.



6.9 Leaving Standby Mode

- Choose the Standby zone to obtain the initial menu.



- Choose [↻] to leave Standby mode and revert to Auto mode.



6.10 Boost Mode – Individual Zones

Boost mode temporarily raises the zone temperature for a non user-configurable period of two minutes.

1. From the Temperature Display screen, select either zone to choose the initial menu.



2. Choose [**X**] to obtain the Function menu.



3. Choose [**Program**] to obtain the Program menu.
Choose [**Boost**] to enter boost mode for the fixed two minute period.



NOTE

If the screen in this step shows the Manual, Standby and Boost buttons greyed out then this function has been inhibited. See page 5-23 for more information.

The screen reverts to main display but you can see the boosted temperature and confirmation message “tup” will flash alternately in the Actual Temperature window.

6.11 Change Set Temperature (Auto or Manual)

Using the up and down buttons changes temperature setting for both Auto and Manual zones.

1. Increase Setting:

Choose the zone to display the initial menu and choose [↑] to raise the temperature.

Choose [✖] to revert to main display.



2. Decrease Setting:

Choose the zone to display the initial menu and choose [↓] to lower the temperature.

Choose [✖] to revert to main display.



Section 7 - Maintenance



WARNING

Ensure that you have fully read “Section 3 - Safety” before doing maintenance procedures on the controller.



CAUTION

External cables should be checked to see that there has been no damage to the flexible conduit, plugs or sockets.

If the flexible conduit has been damaged or if there are any exposed conductors, it must be replaced.

7.1 Service and Repair The Controller

7.1.1 Replacement Parts

We do not expect that you will need to repair any controller parts at board level, other than fuses. In the unlikely event of any board failure then we provide repair and exchange facilities for all our customers. See “Section 2 - Global Support” on page 2-1 for our facilities.

7.1.2 Cleaning and Inspection

Any excess dust that has entered into the cabinet may be removed with a light brush and vacuum cleaner.

If the equipment is subject to vibration then we recommend that you use an insulated screwdriver to check that no terminals have become loose.

7.2 Restore Factory Settings and Recalibration

There are two main functions which are available for restoration and recalibration. These are available via the Factory option which is password protected.

1. From the Temperature Display screen, select either zone to obtain the initial menu.



2. Choose [**X**] to obtain the Function menu.



3. Choose [**Program**] to obtain the Program menu.
Choose [**↑**] or [**↓**] to find the page containing the [**Factory**] option.



4. Enter the password and then choose [**✓**] to access the next screen.



The Factory screen gives the following options:

- Defaults – restore the unit to default settings
- CAL – enter a calibration check routine
- M.Dis – enable or disable user options

These are described on the next page.



7.2.1 Default Settings

These are the settings which would have been applicable when the unit left the factory and was first received. They are:

Table 7-1 Factory Settings	
Zone Temperature	260°C or 500°F
Standby Level	100°C or 180°F
Boost Level	75°C or 135°F
Over Temperature Range	10°C or 18°F
Under Temperature Range	
Ramp	On
Auto-Man	On
Extended Alarms for Manual, Standby and Boost	Off

7.2.2 Calibration Routine

Before starting temperature calibration you need:

- Thermocouple simulator capable of providing accurate set points of 20°C and 400°C.
- Suitable connector plug so that you can connect your simulator to the appropriate zones without any heater zones being connected. If in doubt, consult the loom wiring diagram to check for heater and thermocouple pin connections.

7.2.3 Calibration Sequence

1. Connect the simulator to the normal thermocouple inputs for both zones on the module being calibrated.
2. Choose [Cal] and [✓] to start the calibration routine.
3. The screen asks for a 20°C source – set your thermocouple simulator to 20°C.
4. The screen timer counts down as it sets the low range setting.
5. The screen asks for 400°C source – set your thermocouple simulator to 400°C.
6. The screen timer counts down as it sets the high range setting.
7. The screen informs you that the calibration has completed.
8. Remove the thermocouple simulator and temporary connector.

7.2.4 M.Dis Option

A user can be prevented from choosing Manual Control, Standby or Boost function if the M.Dis (Manual Disabled) box is selected on this screen:

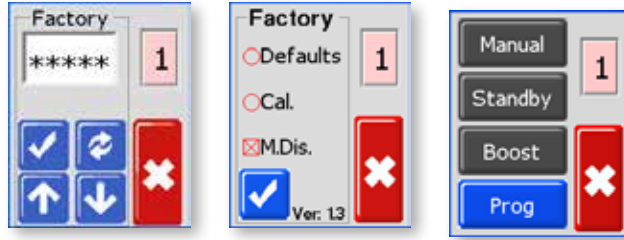

7.3 Fuses and Overcurrent Protection



WARNING - HIGH VOLTAGE

Always isolate your controller at source before you open the unit to inspect it or replace fuses.



CAUTION

If any fuse has ruptured, it must be replaced with a new one with identical characteristics.

The modular circuit breaker (MCB) offers general over-current protection and there are fuses for various sub-circuits. Of the two rear panel-mounted fuses, one protects the cooling fans and the second protects the internal back-plane distribution which feeds the individual cards.

The tables under each heading in the following sections show the correct fuse type.

7.3.1 Fans

If any fan has stopped working, first inspect the unit to see if there are any blockages or objects fouling the impellers. If the fan is free to rotate, then check the panel-mounted fuse at the rear of the unit.

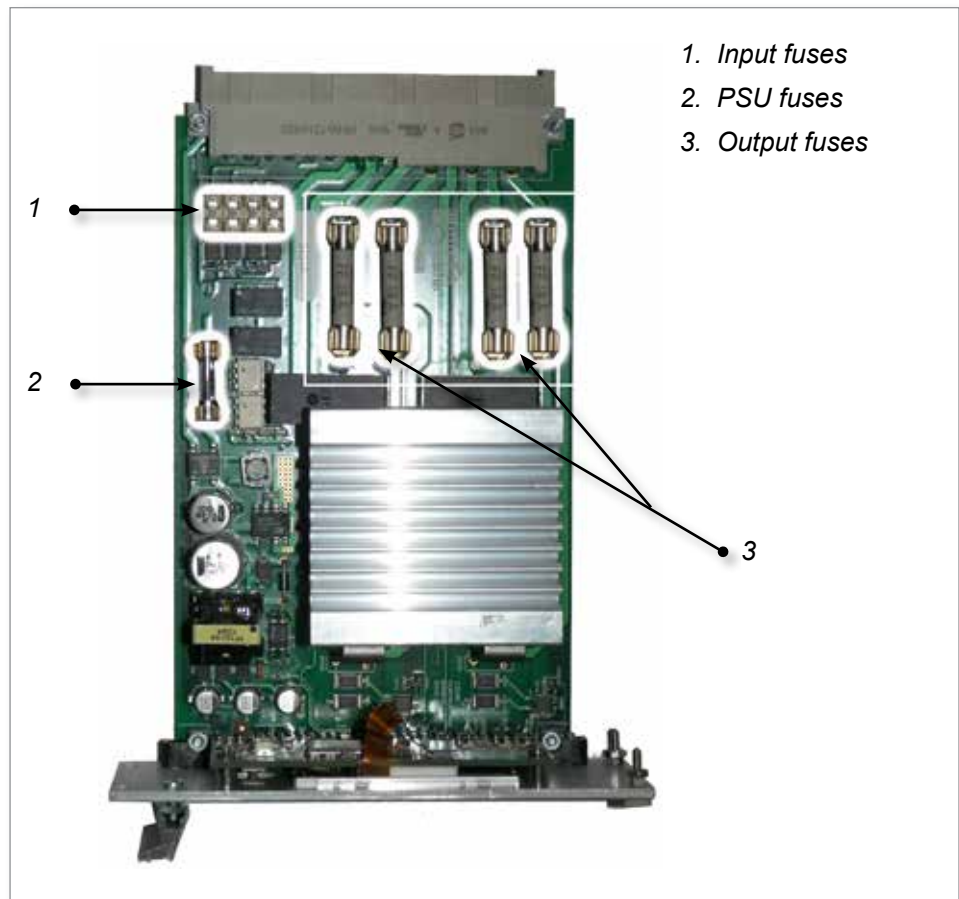

Figure 7-1 Fuse location on a controller card

Fans - continued

Fan fuse specifications are found in Table 7-2:

Table 7-2 Fan Fuses	
Fuse	32mm Anti-surge
Rating	2A

7.3.2 Controller Cards

Each module card has separate protection fuses for its onboard power supply, for the thermocouple input and for the heating load output.

See “Figure 7-1 Fuse location on a controller card” for the layout.

7.3.3 Onboard Power Supply

The module power supply has a mains-voltage glass fuse located beside the power supply circuit.

Table 7-3 Onboard Power Supply Fuse	
Fuse	20mm Anti-surge
Rating	1.6 A

7.3.4 Output Fuse Type: HRC High Speed

If the module shows a “FUSE” alarm, then the card may be easily removed to change the fuse.

Table 7-4 Output Fuse Type	
Fuse	32mm Ceramic FF Ultra Fast
Rating	15A

7.3.5 Input Fuse Type: Surface-Mount Quick-Blow

If the module shows a “T/C” alarm then this may indicate that the input fuse has ruptured. The card may be easily removed and the fuse changed.

Table 7-5 Input Fuse Type	
Part Code	Nano Ceramic Very fast
Rating	62mA

Section 8 - Troubleshooting



WARNING

Ensure that you have fully read “Section 3 - Safety” before troubleshooting any issues with the controller.

8.1 Individual Card Diagnostics

The control system has several features which provide a diagnosis of faults in the control system, the tool heaters and thermocouple sensors.

If a zone temperature is seen to deviate from the actual setting beyond the alarm limits, then the display will change to white text in red box and generate a remote alarm. See “Table 8-1 Alarm Conditions”.

Table 8-1 Alarm Conditions		
Error Message	Cause	Action
ERR!	Little or no temperature rise has been detected in that zone. When power is applied, there should be a corresponding heat rise at the thermocouple. If the thermocouple has been pinched in the tool or the cable, the full heat rise that occurs at the tip is not detected. If left uncorrected then there is a danger that the zone could overheat and damage the tip. The circuit will maintain the output at whatever level it reached when the monitor circuit detected the fault.	Check thermocouple wiring, as it may be reversed. Heater wiring may be faulty or element may be open circuit.
FUSE	The output fuse for that zone has failed. Please note: A fuse can only fail due to a fault external to the controller. Identify and rectify the fault before replacing the fuse. Note: The fuse detection circuit requires a continuous low level current through a high impedance bleed resistor to maintain the alarm condition. As a result, the load circuit is still connected to the mains voltage supply, and it is not safe to attempt to repair or replace the fuse without first isolating the circuit. If the fuse in question is mounted on a control card then it is safe to unplug the board in order to isolate the circuit and replace the fuse on the card.	Replace the fuse with one of the same rating and type, i.e. High Rupture Current load fuse. The fuse is located on the control card.
GND	The system has detected an earth fault.	Check the heater wiring for a low impedance path to earth.

Individual Card Diagnostics - continued

Table 8-1 Alarm Conditions		
Error Message	Cause	Action
LINE	No mains supply synchronisation pulses being received. The three-phase supply is used in a cross-over detection circuit to generate timing pulses for accurate phase control and firing the triac. If the phase detection fails on one or two phases then there is no pulse to use to measure phase angle and the LINE error message is generated. Meanwhile, all circuits on the healthy phases will continue to work normally.	There is a phase detection within the controller. The most common error is either the absence of one phase or, if a plug has been rewired incorrectly, a swapped phase and neutral. In rare cases, a fault within the circuit may cause the LINE error message. If a LINE error message occurs, switch off and isolate the controller then check supply wiring for presence of all three phases.
REV	The card has detected an abnormal input at the thermocouple termination that indicates a shorted or reversed thermocouple.	If the REV alarm persists, switch off the controller and investigate the offending zone. The offending zone can also be slaved to a good zone until you have time to clear the fault.
T/C	An open circuit thermocouple has been detected and no auto-response has been selected in the T/C Open Error column of the Setup page.	For immediate recovery you can either slave that control zone to an adjacent zone or change to open loop control.

8.2 Other Possible Fault Conditions

8.2.1 Rapid Temperature Fluctuations

The most likely cause of temperature fluctuations is extraneous voltages being picked up by the thermocouple cable, i.e. common mode. This may be due to poor earthing of the tool, a faulty shielded thermocouple wire or a faulty heater. We recommend that all earth connections be tested.

8.2.2 Ground Fault Detection

Ground fault detection detects any fault caused by earth leakage current. Earth faults can be caused if a tool has been idle for some time and damp has gotten into one heater. If the heater can be identified, the faulty zone can be repaired by using the adjacent heaters to heat it up and dry it out.

8.3 Module Removal



WARNING

The shrouded terminals on the Euroback board are live unless the power supply is switched to OFF.

To remove a control module from its slot, unscrew the four corner screws first. There is no need to switch off the main supply. However, if operational requirements allow, the cabinet may be isolated.

Section 9 - Wiring Details



WARNING

Ensure that you have fully read “Section 3 - Safety” before connecting the controller.



CAUTION

Please take extreme care when connecting the controller to the three-phase supply. Incorrect connection may appear to work but can result in damage to the controller.

The following standards only apply to controllers wired to *Mold-Masters* standard. Other specifications may have been stated when the controller was ordered. Please refer to the supplied specification details.

9.1 Single Phase Supply Cable



WARNING

Cable colors may vary. Always wire up according to the cable markings.



IMPORTANT

This configuration is **only for MT-02-02** controllers.

The three core cable is provided without a mains supply connector. The cable should be fitted with an appropriate connector for the country in which it is being used.

Table 9-1 Cable Markings for Single Phase Supply Cable (MT-02-02)			
Cable Marking	Color	Supply Description	
		For 5 wire star or (Wye 380 VAC)	For 4 wire (Delta 220 VAC)
L	Brown	Phase	Phase 1
N	Blue	Neutral	Phase 2
G	Green / yellow	Earth	Earth

9.2 Three Phase Designation



WARNING

Cable colors may vary. Always wire up according to the cable markings.



IMPORTANT

This configuration is for **all MT Series controllers except MT-02-02.**

The controller is supplied according to your requirements in either a Star or Delta supply.

9.2.1 Five Wire Star 380VAC

Table 9-2 Cable Markings - 5 Wire Star		
Cable Marking	Color	Supply Description
R	Black	Phase 1
S	Grey	Phase 2
T	Brown	Phase 3
N	Blue	Neutral
G	Green / yellow	Earth

See “9.2.2 Set Power Terminal Block to STAR Configuration” on page 9-3 for more information.

9.2.2 Set Power Terminal Block to STAR Configuration



WARNING

Ensure that the controller has been isolated from all power sources before the wiring is changed.

Cable colors may vary. Always wire up according to the cable markings.

1. Connect the neutral wire of the main power cord into the lower right terminal, as indicated by the blue conductor. See Figure 9-1.

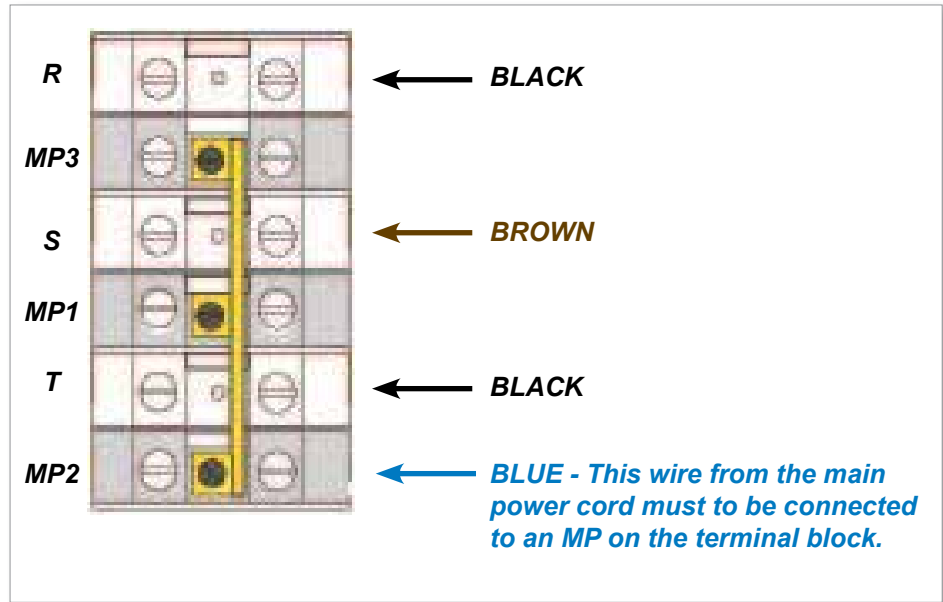

Figure 9-1 Connect the neutral - position shown by blue arrow

2. Join MP1, MP2 and MP3 to the blue N conductor on the terminal block. Refer to Figure 9-2.

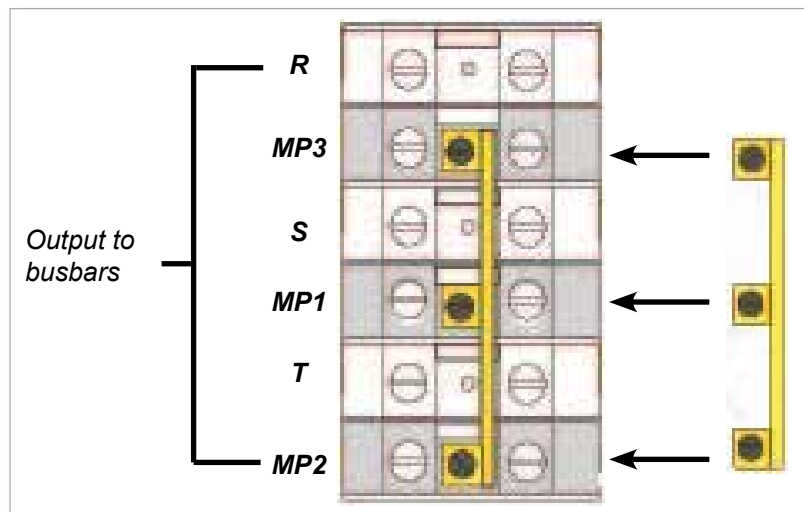

Figure 9-2 Install the three way link

9.2.3 For Four Wire Delta 240V



WARNING

Cable colors may vary. Always wire up according to the cable markings.



NOTE

Delta configurations are supplied with the neutral wire cut from the main power cord.

Table 9-3 Cable Markings for Four Wire Star		
Cable Marking	Color	Supply Description
R	Black	Phase 1
S	Grey	Phase 2
T	Brown	Phase 3
G	Green / yellow	Earth

See “9.2.4 Set Power Terminal Block To DELTA Configuration” on page 9-5 for more information.

9.2.4 Set Power Terminal Block To DELTA Configuration



WARNING

Ensure that the controller has been isolated from all power sources before the wiring is changed.

Cable colors may vary. Always wire up according to the cable markings.

1. Remove the neutral wire of the main power cord from the lower right terminal as indicated by the blue conductor, and make it safe. See Figure 9-3.

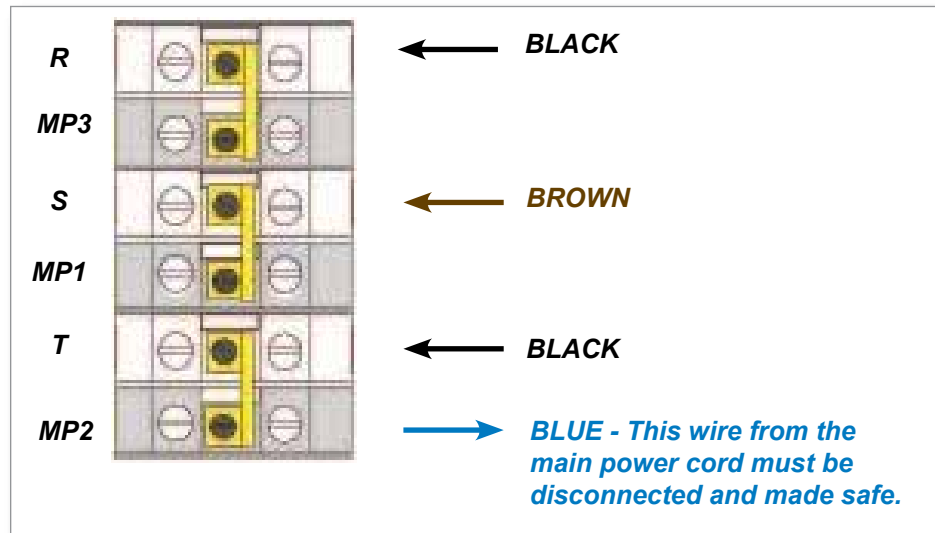

Figure 9-3 Remove the neutral wire - position shown by the blue arrow

2. Join MP3, MP1 and MP2 with the three 2-way links. Refer to Figure 9-4.

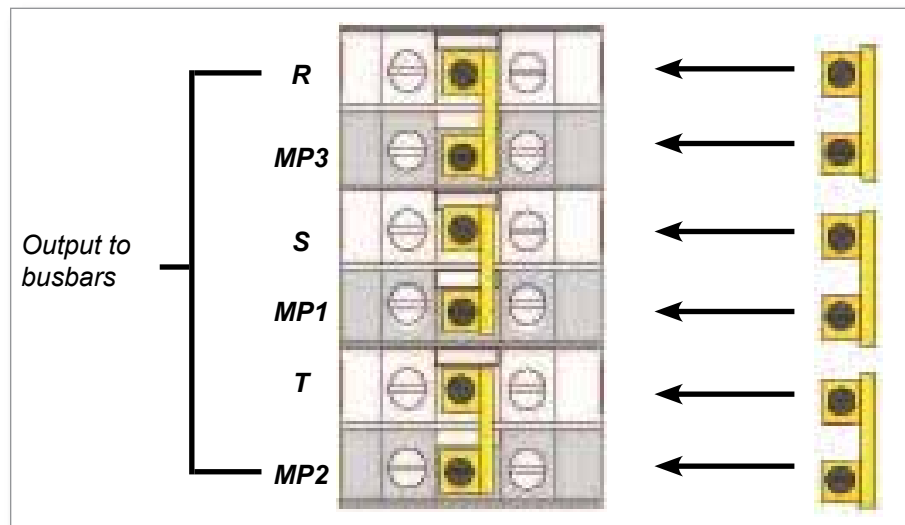

Figure 9-4 Install the three 2-way links



IMPORTANT

Do not link MP1, MP3 and MP2 together.

9.3 Filter Option

In countries where noise across power lines is a concern, *Mold-Masters* recommends that an inline filter is fitted. Please contact *Mold-Masters* for details.

9.4 Alarm Output



NOTE

This section is not applicable for the MT-02-02 controller.

A HAN4A connector provides an alarm output from an internal set of relay contacts. Using an external power source the cabinet can initiate a number of warning devices whenever any zone goes into an alarm state. This is commonly used for beacons, audible alarms or informing the molding machine. The contacts are rated for 2A at 125VAC/60VDC.

An input can be accepted through the same connector. It may be used for Remote Standby mode. For exact details, consult the specification for the particular model.

Table 9-4 HAN4A Pin Connections		
Pin	Connection	Input / Output
1	Auxiliary Input signal	Standby Port (Dry Contact Signal)
2	Auxiliary Input Ground	
3	Alarm Output Contact	Normally Open Dry Contacts
4	Alarm Output Contact	

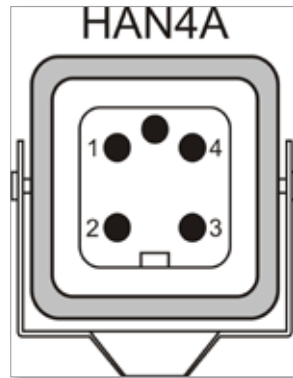

Figure 9-5 HAN4A connector

9.5 Standard Tool Connections

The following pages show the connections for the MT controller to the tool.

9.5.1 MT-02-02



WARNING

Three different configurations are used with an MT-02-02 system, depending on the geographic location of the controller. It is the responsibility of the integrator to identify and implement the correct tool wiring.

9.5.2 MT-02-02 For UK and Europe

The mold plug for the tool is Harting Han 10 A® male insert with Han 10 A® single locking level housing. See Figure 9-6.

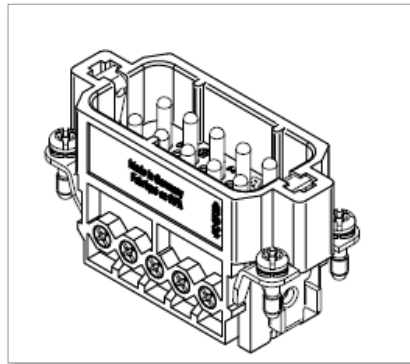

Figure 9-6 Harting Han 10 A® insert for MT-02-02

The pin configuration can be found in Table 9-5:

Table 9-5 MT-02-02 Pin Configuration for UK and Europe				
	Power		Thermocouple	
Zone	Supply	Return	Thermocouple +	Thermocouple -
1	Pin 3	Pin 4	Pin 1	Pin 2
2	Pin 8	Pin 9	Pin 6	Pin 7

The cut out dimensions are shown in Figure 9-6.

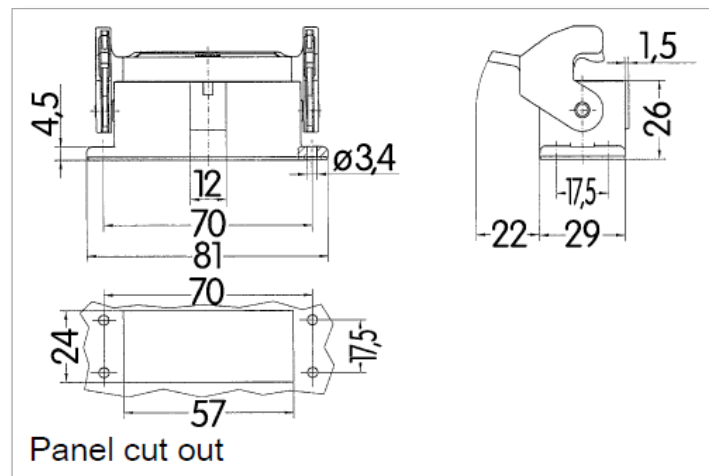

Figure 9-7 Harting Han 10 A® cut out dimensions

Maximum voltage: 220VAC - 10A.

9.5.3 MT-02-02 For India

The mold plug of the tool is Han 16 E® male insert with Han 16 B® double level housing. See Figure 9-8.

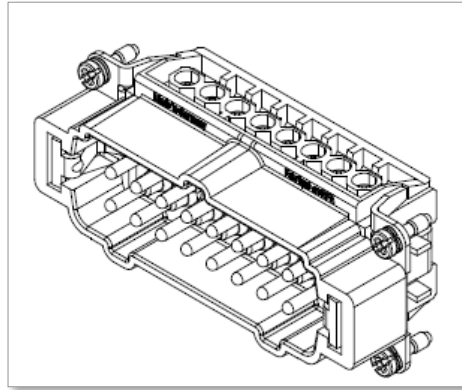

Figure 9-8 Harting Han 16 E® insert for MT-02-02

The pin configuration can be found in Table 9-6:

Table 9-6 MT-02-02 Pin Configuration for India				
Zone	Power		Thermocouple	
	Supply	Return	Thermocouple +	Thermocouple -
1	Pin 9	Pin 10	Pin 1	Pin 2
2	Pin 11	Pin 12	Pin 3	Pin 4

The cut out dimensions are shown in Figure 9-9

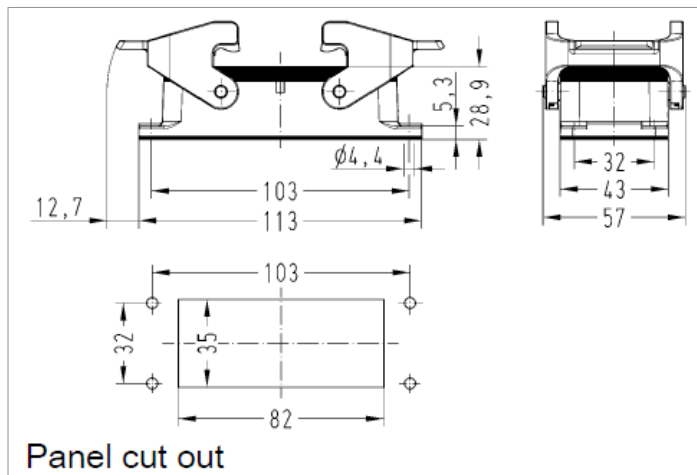

Figure 9-9 Harting Han 16 E® cut out dimensions

Maximum voltage: 220VAC - 10A.

9.5.4 MT-02-02 For North America

The mold plug of the tool is a Han 10 E[®] male insert with Han 10 B[®] double level housing. See Figure 9-10.

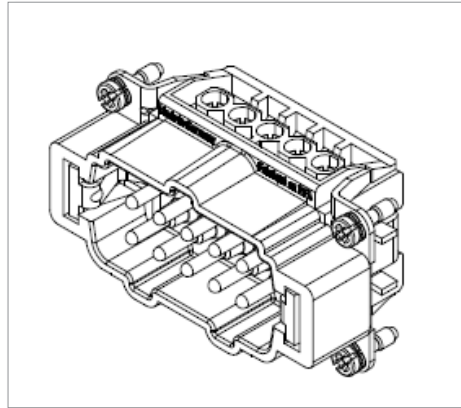

Figure 9-10 Harting Han 10 E[®] insert for MT-02-02

The pin configuration can be found in Table 9-7.

Table 9-7 MT-02-02 Pin Configuration for North America				
	Power		Thermocouple	
Zone	Supply	Return	Thermocouple +	Thermocouple -
1	Pin 1	Pin 2	Pin 6	Pin 7
2	Pin 4	Pin 5	Pin 9	Pin 10

The cut out dimensions are shown in Figure 9-11.

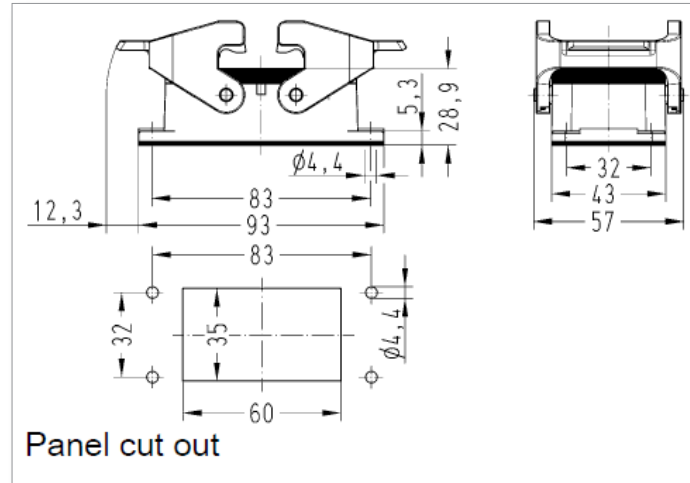

Figure 9-11 Harting Han 10 E[®] cut out dimensions

Maximum voltage: 220VAC - 10A.

9.5.5 MT-04-04

One tool connection configuration is used with MT-04-04 system.

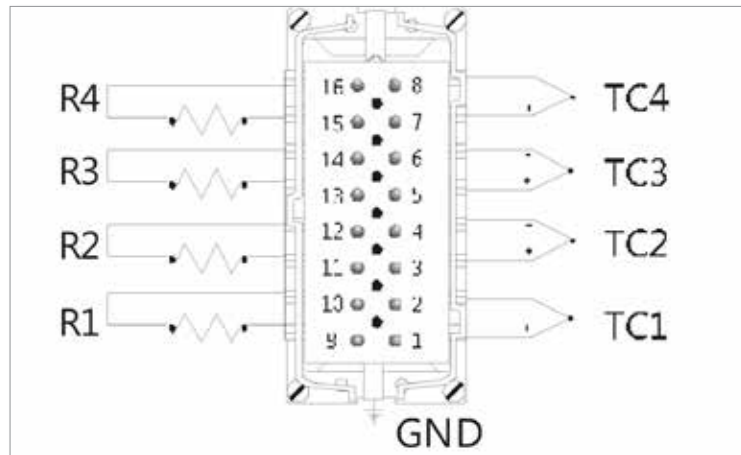

Figure 9-12 Insert for MT-04-04

The pin configuration can be found in Table 9-8:

Table 9-8 MT-04-04 Pin Configuration				
	Power		Thermocouple	
Zone	Supply	Return	Thermocouple +	Thermocouple -
1	Pin 9	Pin 10	Pin 1	Pin 2
2	Pin 11	Pin 12	Pin 3	Pin 4
3	Pin 13	Pin 14	Pin 5	Pin 6
4	Pin 15	Pin 16	Pin 7	Pin 8

The cut out dimensions are shown in Figure 9-13.

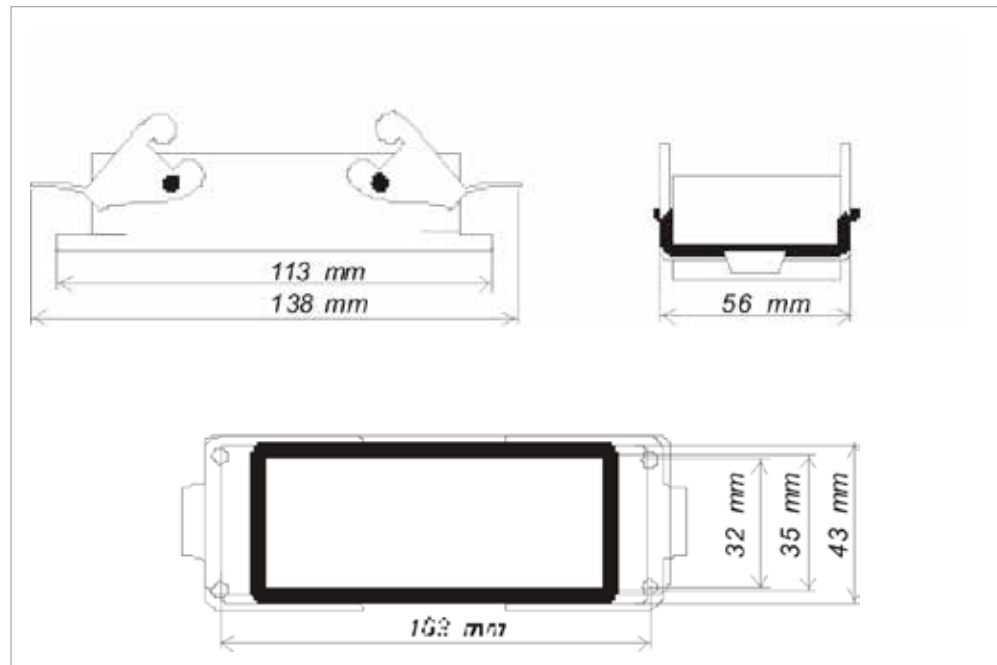

Figure 9-13 MT-04-04 cut out dimensions

Maximum voltage: 230VAC - 16A

9.5.6 MT-06-06

One tool connection configuration is used with an MT-06-06 system.

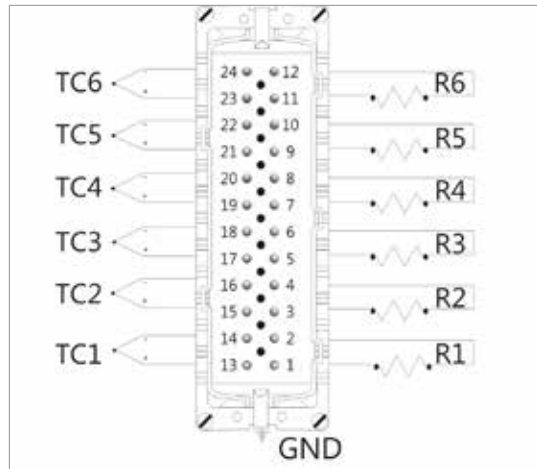

Figure 9-14 Insert for MT-06-06

The pin configuration can be found in Table 9-9:

Table 9-9 MT-06-06 Pin Configuration				
	Power		Thermocouple	
Zone	Supply	Return	Thermocouple +	Thermocouple -
1	Pin 1	Pin 2	Pin 13	Pin 14
2	Pin 3	Pin 4	Pin 15	Pin 16
3	Pin 5	Pin 6	Pin 17	Pin 18
4	Pin 7	Pin 8	Pin 19	Pin 20
5	Pin 9	Pin 10	Pin 21	Pin 22
6	Pin 11	Pin 12	Pin 23	Pin 24

The cut out dimensions are shown in Figure 9-15.

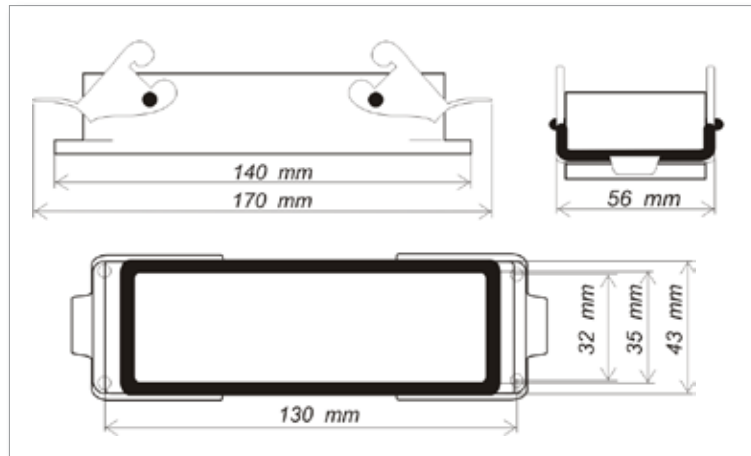

Figure 9-15 MT-06-06 cut out dimensions

Maximum voltage: 230VAC - 16A

9.5.7 MT-12-12 and MT-18-xx



WARNING

Two different configurations are used with MT-12-12 and MT-18-xx systems, depending on the geographic location of the controller. It is the responsibility of the integrator to identify and implement the correct tool wiring.

9.5.8 MT-12-12 and MT-18-xx for UK and Europe

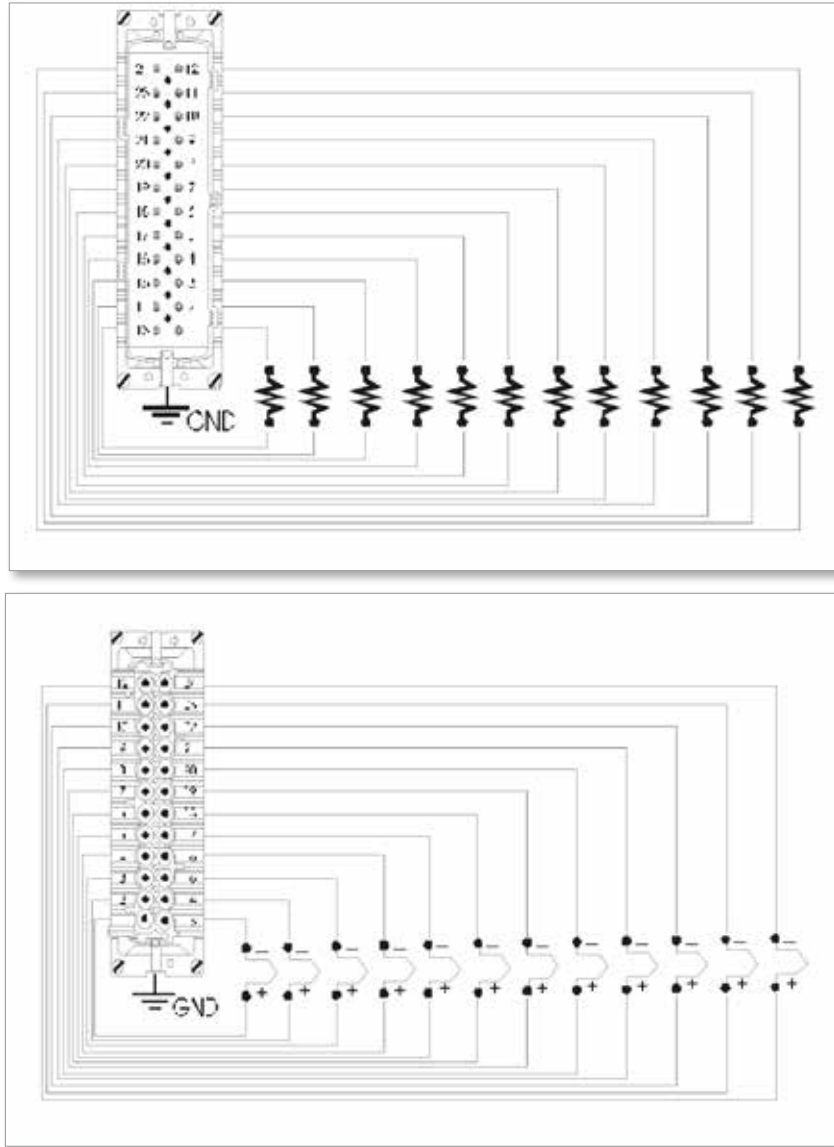

Figure 9-16 Inserts for MT-12-12 and MT-18-xx

MT-12-12 and MT-18-xx for UK and Europe - continued

The pin configuration can be found in Table 9-10:

Table 9-10 MT-12-12 / MT-18-xx Pin Configuration for UK and Europe				
Zone	Power		Thermocouple	
	Supply	Return	Thermocouple +	Thermocouple -
1	Pin 1	Pin 13	Pin 1	Pin 13
2	Pin 2	Pin 14	Pin 2	Pin 14
3	Pin 3	Pin 15	Pin 3	Pin 15
4	Pin 4	Pin 16	Pin 4	Pin 16
5	Pin 5	Pin 17	Pin 5	Pin 17
6	Pin 6	Pin 18	Pin 6	Pin 18
7	Pin 7	Pin 19	Pin 7	Pin 19
8	Pin 8	Pin 20	Pin 8	Pin 20
9	Pin 9	Pin 21	Pin 9	Pin 21
10	Pin 10	Pin 22	Pin 10	Pin 22
11	Pin 11	Pin 23	Pin 11	Pin 23
12	Pin 12	Pin 24	Pin 12	Pin 24

The cut out dimensions are shown in Figure 9-17.

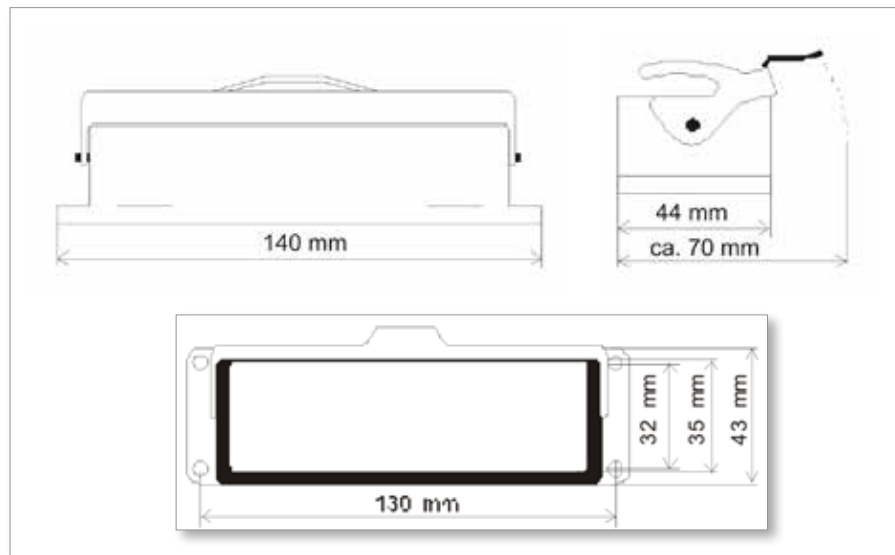

Figure 9-17 MT-12-12 AND MT-18-xx cut out dimensions - UK and Europe

Maximum voltage: 230VAC - 16A

9.5.9 MT-12-12 and MT-18-xx for North America

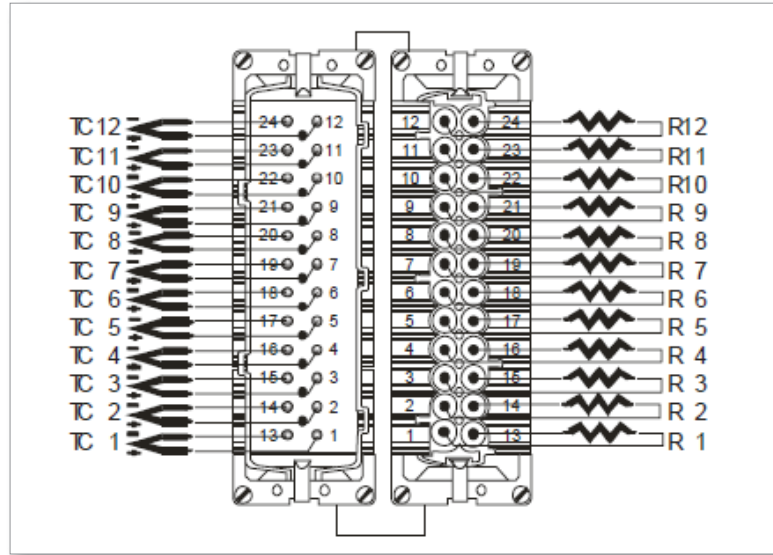

Figure 9-18 MT-12-12 and MT-18-xx inserts (Plug 1 and Plug 2)

The pin configurations for the male insert can be found in Table 9-11:

Zone	Power (Male)		Thermocouple (Female)	
	Supply	Return	Thermocouple +	Thermocouple -
1	Pin 1	Pin 13	Pin 1	Pin 13
2	Pin 2	Pin 14	Pin 2	Pin 14
3	Pin 3	Pin 15	Pin 3	Pin 15
4	Pin 4	Pin 16	Pin 4	Pin 16
5	Pin 5	Pin 17	Pin 5	Pin 17
6	Pin 6	Pin 18	Pin 6	Pin 18
7	Pin 7	Pin 19	Pin 7	Pin 19
8	Pin 8	Pin 20	Pin 8	Pin 20
9	Pin 9	Pin 21	Pin 9	Pin 21
10	Pin 10	Pin 22	Pin 10	Pin 22
11	Pin 11	Pin 23	Pin 11	Pin 23
12	Pin 12	Pin 24	Pin 12	Pin 24

MT-12-12 and MT-18-xx for North America - continued

The pin configurations for the female insert can be found in Table 9-12:

Table 9-12 MT-12-12 / MT-18-xx Pin Configuration for North America (Plug 2)				
Zone	Power (Male)		Thermocouple (Female)	
	Supply	Return	Thermocouple +	Thermocouple -
13	Pin 1	Pin 13	Pin 1	Pin 13
14	Pin 2	Pin 14	Pin 2	Pin 14
15	Pin 3	Pin 15	Pin 3	Pin 15
16	Pin 4	Pin 16	Pin 4	Pin 16
17	Pin 5	Pin 17	Pin 5	Pin 17
18	Pin 6	Pin 18	Pin 6	Pin 18
19	Pin 7	Pin 19	Pin 7	Pin 19
20	Pin 8	Pin 20	Pin 8	Pin 20
21	Pin 9	Pin 21	Pin 9	Pin 21
22	Pin 10	Pin 22	Pin 10	Pin 22
23	Pin 11	Pin 23	Pin 11	Pin 23
24	Pin 12	Pin 24	Pin 12	Pin 24

The cut out dimensions are shown in Figure 9-19.

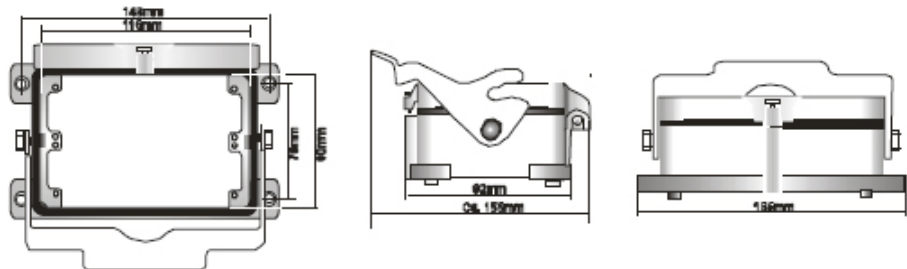

Figure 9-19 MT-12-12 AND MT-18-xx cut out dimensions - North America

Maximum voltage: 230VAC - 16A

Index

A

Alarm Output 9-5

C

Calibration Routine 7-3

Controller Modules 4-5

D

Default Settings 7-3

E

Error Message 8-1

Extending Alarms 5-25, 5-26

G

Ground Fault Detection 5-17

H

How the MT Controller Works 4-6

I

Inhibiting Manual, Standby or Boost 5-24

L

Language 5-27

M

Mold Leak Detection 5-19

O

Operation Principles 6-1

P

PID Characteristics 5-7

R

Ramp 5-9

S

Safety

Lockout 3-10

Safety Instructions 3-1

Safety Symbols

General Descriptions 3-8

Service and Repair 7-1

Slave Mode 6-5

Standby and Boost Mode 6-7

Standby Value 5-13

Switching On and Off 4-3

T

Temperature Limits 5-15

Temperature Scale 5-5

Thermocouple Failure 5-21

Trademarks and Patents 1-3

Troubleshooting 8-1

Z

Zone Numbering 5-3

Zone Temperatures 5-28



Global Headquarters

Mold-Masters (2007) Limited
tel: +1 905 877 0185
fax: +1 905 873 2818
e: canada@moldmasters.com

Mexico

Milacron México Plastics Services,
S.A. de C.V.
tel: +52 442 713 5661 (sales)
tel: +52 442 713 5664 (service)
e: mexico@moldmasters.com

U.S.A.

Mold-Masters Injectioneering LLC
tel: +1 800 450 2270 (USA only) tel:
+1 (248) 544 5710
fax: +1 (248) 544 5712
e: usa@moldmasters.com

South American Headquarters

Brazil

Mold-Masters do Brasil Ltda.
tel: +55 19 3518 4040
e: brazil@moldmasters.com

European Headquarters

Mold-Masters Europa GmbH
tel: +49 7221 50990
fax: +49 7221 53093
e: germany@moldmasters.com

Austria / East and South East Europe

Mold-Masters Handelsges.m.b.H.
tel: +43 7582 51877
fax: +43 7582 51877 18
e: austria@moldmasters.com

France

Mold-Masters France
tel: +33 (0) 1 78 05 40 20
fax: +33 (0) 1 78 05 40 30
e: france@moldmasters.com

Spain

Mold-Masters Europa GmbH
tel: +34 93 575 41 29
fax: +34 93 575 34 19
e: spain@moldmasters.com

United Kingdom & Ireland

Mold-Masters (UK) Ltd
tel: +44 1432 265768
fax: +44 1432 263782
e: uk@moldmasters.com

Turkey

Mold-Masters Europa GmbH
Tel: +90 216 577 32 44
Fax: +90 216 577 32 45
e: turkey@moldmasters.com

Asian Headquarters

Mold-Masters (KunShan) Co, Ltd
tel: +86 512 86162882
fax: +86 512 86162883
e: china@moldmasters.com

India

Mold-Masters Technologies Private Ltd.
tel: +91 422 423 4888
fax: +91 422 423 4800
e: india@moldmasters.com

Japan

Mold-Masters K.K.
tel: +81 44 986 2101
fax: +81 44 986 3145
e: japan@moldmasters.com

Korea

Mold-Masters Korea Ltd.
tel: +82-31-278-4757
fax: +82-10-4569-4756
e: korea@moldmasters.com

Singapore

Mold-Masters Singapore PTE Ltd.
tel: +65 6261 7793
fax: +65 6261 8378
e: singapore@moldmasters.com