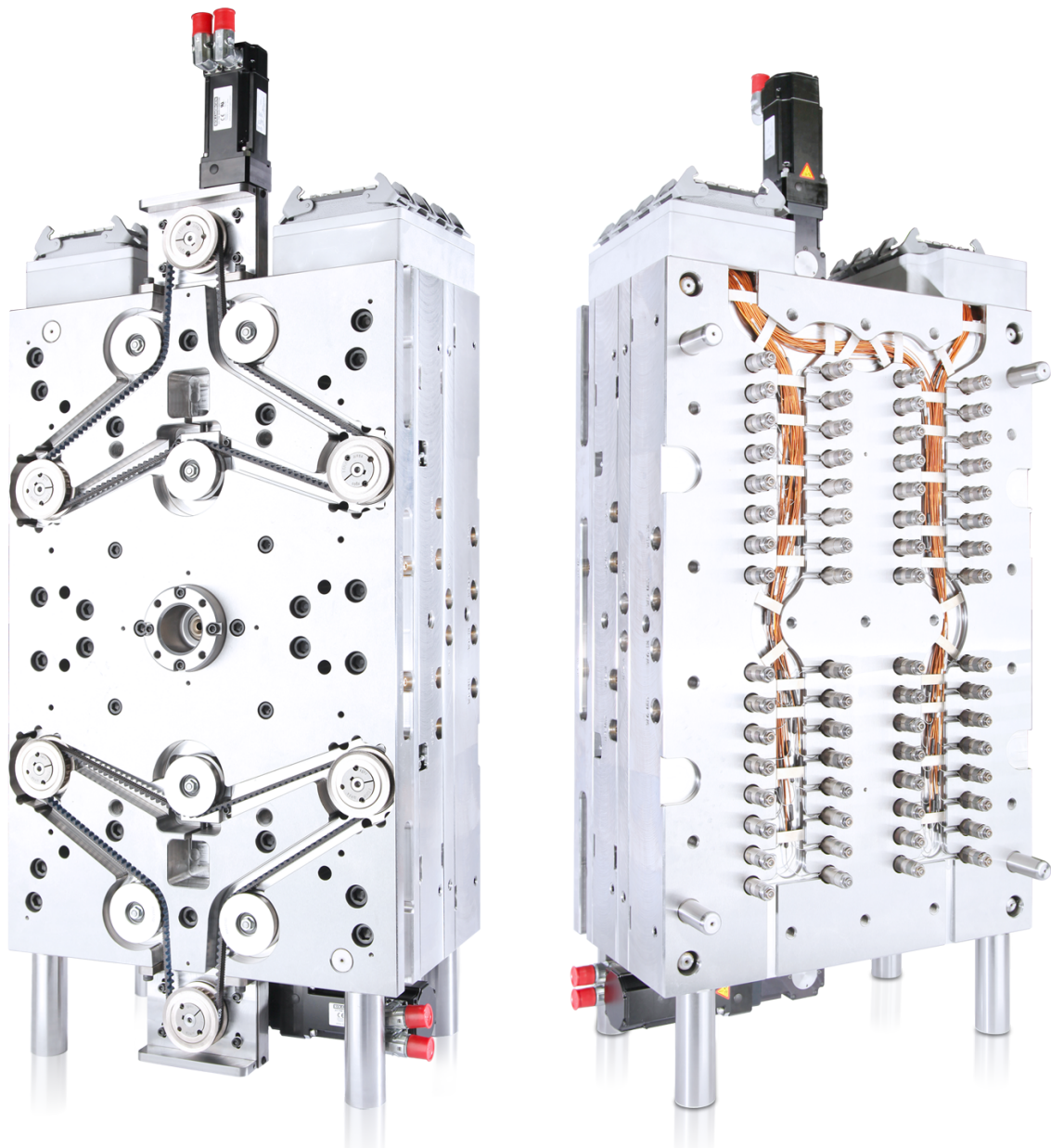


Hot Runner

User Manual

version 33-2



Contents

- Section 1 - Introduction1-1**
 - 1.1 Intended Use 1-1
 - 1.2 Documentation 1-1
 - 1.2.1 User-Manual Release Details 1-1
 - 1.3 Warranty 1-2
 - 1.4 Returned Goods Policy 1-2
 - 1.5 Movement or Resale of Mold-Masters Products or Systems 1-2
 - 1.6 Copyright 1-2
 - 1.7 Units of Measure and Conversion Factors 1-3

- Section 2 - Global Support2-1**
 - 2.1 Worldwide Locations 2-1

- Section 3 - Safety.....3-1**
 - 3.1 Overview..... 3-2
 - 3.2 Operational Hazards..... 3-5
 - 3.3 General Safety Symbols 3-7
 - 3.4 Wiring Check 3-8
 - 3.5 Lockout Safety 3-9
 - 3.5.1 Electrical Lockout..... 3-10
 - 3.5.2 Energy Forms and Lockout Guidelines..... 3-11
 - 3.6 Disposal..... 3-12
 - 3.7 Hot Runner Safety Hazards..... 3-13

- Section 4 - Preparation4-1**
 - 4.1 Tools Required..... 4-1
 - 4.2 Screws 4-2
 - 4.2.1 Length..... 4-2
 - 4.2.2 Grade..... 4-2
 - 4.3 Tighten Settings 4-3
 - 4.3.1 Master-Series Gate Seals..... 4-3
 - 4.3.2 Summit-Series Gate Seals 4-3
 - 4.3.3 Others 4-3
 - 4.4 Unpacking..... 4-5
 - 4.5 Cleaning 4-5
 - 4.6 Overview of System Types 4-6
 - 4.6.1 Non-Valved System 4-6
 - 4.6.2 Valve Gate System 4-7
 - 4.6.3 Valve Gate System with Bridge 4-8
 - 4.6.4 Non-Valved System with Master-Shield Technology 4-9
 - 4.6.5 Valved System with Master-Shield Technology 4-10
 - 4.7 System Cutaways 4-11
 - 4.7.1 Brazed-in/Paste-in System 4-11
 - 4.7.2 Bolt-in System..... 4-12

4.7.3 Master-Shield System.....	4-13
---------------------------------	------

Section 5 - Assembly5-1

5.1 Finishing a Gate Seal	5-1
5.2 Installing a Water-Cooled Gate Insert.....	5-1
5.3 Installing a Thermocouple	5-2
5.3.1 Installing a Master Series-style Thermocouple.....	5-2
5.3.2 Removing a Non-Front Mounted Thermocouple	5-5
5.4 Installing a Nozzle	5-6
5.4.1 Master-Shield Centi, Deci, and Pico	5-7
5.4.2 Master-Shield Femto	5-10
5.5 Installing a Nozzle Step.....	5-14
5.6 Nozzle Wire Layout	5-15
5.6.1 Back Mounted Thermocouples	5-15
5.6.2 Front Mounted Thermocouples.....	5-15
5.7 Installing a Valve Bushing.....	5-16
5.7.1 Types	5-16
5.7.2 Installing.....	5-16
5.8 Installing a Manifold.....	5-18
5.8.1 Manifold Locator	5-19
5.8.2 Manifold Locating Dowel Pin	5-20
5.8.3 Installing a Manifold Thermocouple	5-21
5.9 Installing a Main Manifold	5-22
5.9.1 Installing an Inlet Seal.....	5-22
5.9.2 Installing a Manifold Step.....	5-23
5.10 Installing a Pressure Disk or a Valve Disk in a Master-Series System.....	5-23
5.10.1 Pressure Disk: Final Grinding Required	5-24
5.10.2 Installing a Pressure Disk	5-26
5.10.3 Pressure Disk: Final Grinding Not Required.....	5-26
5.10.4 Installing a Valve Disk.....	5-27
5.11 Installing a Support Bushing or a Valve Disk in a Master-Shield System	5-28
5.11.1 Installing a Support Bushing	5-28
5.11.2 Installing a Valve Disk	5-29
5.12 Installing a Heater Plate	5-31
5.13 Installing Inlet Components	5-33
5.13.1 Unheated Back Plate	5-33
5.13.2 Heated Back Plate	5-34
5.13.3 Center Heater (Direct mount)	5-35
5.13.4 Center Heater (Indirect mount).....	5-36
5.13.5 Inlet Extension	5-37
5.13.6 Inlet Extension with Pressure Sleeves.....	5-38
5.14 Hydraulic and Pneumatic Actuators.....	5-39
5.14.1 Valve Actuator Assembly	5-39
5.14.2 Pre-Installation.....	5-40
5.14.3 Recommendations for Valve-Gate Air Circuits.....	5-40
5.14.4 Assembling a Cylinder Bottom.....	5-41
5.14.5 Piston Assembly	5-42
5.14.5.1 5500 Series	5-42
5.14.5.2 6X00 and 7100 Series	5-42
5.14.6 Assembling a Cylinder Top	5-43

5.14.7 Finishing the Tip of a Valve Pin.....	5-43
5.14.7.1 5500 Series	5-43
5.14.7.2 6X00 Series	5-45
5.14.7.3 7100 Series	5-45
5.14.7.4 8X00 Series	5-47
5.14.7.5 8600.....	5-48
5.14.8 Lapping a Tapered Valve Pin—5500 and 6X00 Series.....	5-49
5.14.9 Finishing the Head of a Valve Pin—5500 Series	5-50
5.15 Valve Pin Assembly	5-51
5.15.1 5500 Series.....	5-51
5.15.2 6X00 Series	5-51
5.15.3 7100 Series.....	5-52
5.16 Installing a Valve Actuator in a Hydraulic Plate	5-53
5.16.1 5500 Series.....	5-53
5.16.2 6X00 Series	5-54
5.17 Installing a Hydraulic Limit-Switch Option—6500 and 6600 Series.....	5-55
5.17.1 Installing a Proximity Sensor	5-56
5.17.2 Cutout Options Based on Stroke	5-57
5.18 Testing the Proximity Sensor of a Hydraulic Limit-Switch Option	5-58
5.19 SeVG Plus Actuator	5-59
5.20 E-Drive.....	5-60
5.20.1 Typical System.....	5-60
5.20.2 Components	5-62
5.20.3 Safety.....	5-63
5.20.4 Assembly	5-64
5.20.5 Attaching a Hot Runner Assembly	5-65
5.20.6 Attaching a Plate Assembly	5-65
5.20.7 Assembling a Synchro-Plate.....	5-66
5.20.8 Preparing a Ball Screw	5-67
5.20.9 Lubricating a Ball Screw	5-67
5.20.10 Assembling a Ball Screw	5-68
5.20.11 Maintaining a Ball Screw.....	5-69
5.20.12 Assembling a Top Plate	5-69
5.20.13 Attaching a Synchro-Plate to a Top Plate Assembly.....	5-69
5.20.14 Assembling a Tension Belt.....	5-69
5.20.15 Inspecting the Parallelism of the Synchro-Plate	5-71
5.20.16 Assembling an Insulation Plate and a Locating Ring.....	5-71
5.20.17 Doing E-Drive Controller Checks.....	5-72
5.20.18 Installing a Hot Half in a Mold	5-72
5.20.19 Installing or Replacing a Belt	5-72
5.20.20 Doing a Check for Misalignment.....	5-74
5.21 Mag-Pin Option.....	5-75
5.21.1 Assembly	5-76
5.21.2 Safety.....	5-76
5.21.3 Operation	5-77
5.21.4 Handling Magnets.....	5-79
5.21.5 Summary of the Assembly Procedure	5-80
5.21.6 Assembling	5-80
5.21.6.1 Placing a Magnet on Top of the Magnet Retainer	5-80
5.21.6.2 Checking the Polarity of a Magnet.....	5-81
5.21.6.3 Cleaning a Magnet Holder.....	5-81

5.21.6.4	Installing a Magnetic Retainer in a Magnet Holder.....	5-82
5.21.6.5	Placing a Magnet Holder and Magnet into a Housing	5-82
5.21.6.6	Assembling a Nut and a Lock Magnet Holder	5-83
5.21.6.7	Installing a Valve Pin in a Valve Pin Holder	5-83
5.21.6.8	Installing an O-Ring in a Valve Pin Holder.....	5-84
5.21.6.9	Installing a Valve Pin in a Housing Assembly	5-84
5.21.6.10	Installing a Mag-Pin Assembly in a Synchro-Plate	5-85
5.22	Single Nozzle Valve System (Accu-Line)	5-86
5.22.1	Femto, Pico, Centi Accu-Line with Valve Bushing	5-86
5.22.1.1	Pre-Assembly	5-87
5.22.1.2	Assembling an Accu-Line System	5-87
5.22.2	Deci and Hecto Accu-Line with Valve Insert	5-94
5.22.2.1	Pre-Assembly	5-95
5.22.2.2	Assembling an Accu-Line System	5-97
5.23	TIT Edge-Gated System.....	5-107
5.23.1	Removing TIT Edge Gate Seals	5-107
5.24	Melt-Disk System.....	5-108
5.24.1	Identifying a Reverse Melt-Link	5-108
5.24.2	Example.....	5-109
5.24.3	Preparing and Cleaning.....	5-110
5.24.4	Assembling a Melt-Disk Thermocouple	5-112
5.24.5	Installing a Melt Disk in a Nozzle.....	5-114
5.24.5.1	Reverse Two-Piece Melt-Link.....	5-114
5.24.5.2	One-Piece Melt-Link.....	5-115
5.24.6	Optional Quick Disconnect Terminal Ends.....	5-116
5.24.6.1	Crimping the Quick Disconnects	5-117
5.25	Melt-Cube Systems	5-118
5.25.1	Identifying Your Melt-Cube Design	5-118
5.25.2	Melt-Cube Design A (Angled version).....	5-118
5.25.3	Melt-Cube Design B (Horizontal version)	5-119
5.25.4	Example.....	5-120
5.25.5	Melt-Cube Design A.....	5-121
5.25.5.1	Gate Seal Assembly	5-122
5.25.5.2	Maintenance Toolkit.....	5-122
5.25.5.3	Dual Nozzle Assembly.....	5-123
5.25.5.4	Inspecting	5-123
5.25.5.5	Cleaning	5-123
5.25.5.6	Assembling a Melt-Cube Thermocouple.....	5-124
5.25.5.7	Assembling a Ground Wire.....	5-124
5.25.5.8	Installing a Melt Transfer Link.....	5-125
5.25.5.9	Installing in a Cavity Block.....	5-126
5.25.5.10	Assembling (Cold Condition)	5-126
5.25.5.11	Tightening the Melt Wedge Screws (Hot Condition)	5-131
5.25.5.12	Replacing a Transfer-Seal/Torpedo	5-133
5.25.6	Melt-Cube Design B.....	5-136
5.25.6.1	Components	5-136
5.25.6.2	Maintenance Toolkit.....	5-137
5.25.6.3	Inspecting	5-137
5.25.6.4	Cleaning	5-138
5.25.6.5	Installing a Thermocouple.....	5-139

- 5.25.6.6 Attaching a Ground Wire5-140
- 5.25.6.7 Installing a Melt Transfer Link5-140
- 5.25.6.8 Assembling5-142
- 5.25.6.9 Installing Gate Seals and Cavity Inserts5-144
- 5.25.6.10 Installing a Melt Block.....5-145
- 5.25.6.11 Disassembling a Transfer-Seal/Torpedo and a Melt Block ..5-146
- 5.25.6.12 Installing a Melt-Cube in a Cavity Block5-148
- 5.26 DeXa Systems (Side Gating).....5-149
 - 5.26.1 Two-Tip DeXa Nozzle5-149
 - 5.26.2 Four-Tip DeXa Nozzle5-149
 - 5.26.3 DeXa Nozzle Package—Four Tip5-150
 - 5.26.4 Installing a DeXa Nozzle.....5-151
 - 5.26.5 Disassembling a DeXa Nozzle5-151
 - 5.26.6 Orientations of Nozzle Terminal Ends and Wiring Diagrams5-152

Section 6 - Hot Half Assembly6-1

- 6.1 Assembling a Hot Half6-1
- 6.2 Installing a Stack-Mold Cavity Plate6-3

Section 7 - Electrical Testing7-1

- 7.1 Safety7-1
- 7.2 Doing a Check of the Electrical Wiring7-1
- 7.3 Electrical Safety Testing7-2
 - 7.3.1 Doing a Check of Equipment7-2
 - 7.3.2 Doing a Test of the Insulation Resistance.....7-2
 - 7.3.3 Doing a Test of the Conditions for Protection by Automatic Disconnection of the Power Supply.....7-3
 - 7.3.4 Doing a Test of the Continuity of the Protective Bonding Circuit7-3
 - 7.3.5 Doing a Test of the Impedance of the Fault Loop7-3
 - 7.3.6 Doing a Test of the Continuity of a Thermocouple7-4
 - 7.3.7 Doing a Pinch Point Test.....7-4
 - 7.3.8 Doing a Check of the Heating Element.....7-4
 - 7.3.9 Doing a Test of the Continuity of the Ungrounded Thermocouple7-5
- 7.4 Thermocouple Wiring Guidelines7-5
- 7.5 Doing a Functional Test with a Temperature Controller7-5
- 7.6 Retesting7-5

Section 8 - System Startup and Shutdown8-1

- 8.1 Pre-Startup8-1
- 8.2 Startup8-1
 - 8.2.1 Standard Hot Runner Systems8-2
 - 8.2.2 Stack Mold Systems8-2
 - 8.2.3 Melt-Disk8-3
 - 8.2.3.1 Melt-Link8-3
 - 8.2.3.2 Reverse Melt-Link.....8-4
 - 8.2.4 Melt Cube8-4
- 8.3 Shutdown.....8-5

8.3.1 Standard Hot Runner Systems	8-5
8.3.2 Stack Mold Systems	8-5
8.3.3 Melt-Disk.....	8-5
8.3.3.1 Melt Link	8-6
8.3.3.2 Reverse Melt Link.....	8-6
8.3.4 Melt-Cube	8-6

Section 9 - Color Change.....9-1

9.1 General Tips	9-1
9.2 Procedure A: Simple and Effective	9-1
9.3 Procedure B: Comprehensive	9-2

Section 10 - Maintenance..... 10-1

10.1 Extraction Puller Overview	10-2
10.2 Valve Disks	10-3
10.2.1 Removing a One-Piece Valve Disk.....	10-3
10.2.2 Removing a One-Piece Valve Disk (Close pitch).....	10-6
10.2.3 Removing a Two-Piece Valve Disk (Thread extraction).....	10-10
10.2.4 Removing a Two-Piece Valve Disk (Groove extraction)	10-13
10.3 Terminal Ends.....	10-16
10.3.1 Removing.....	10-16
10.3.2 Installing.....	10-16
10.3.3 Assembling a Terminal End	10-17
10.4 Heater Plates.....	10-19
10.4.1 Removing a Power Lead	10-19
10.4.2 Installing a Power Lead	10-20
10.5 Gate Seals.....	10-20
10.5.1 Heating the System	10-20
10.5.2 Removing a Gate Seal.....	10-21
10.5.3 Replacing a Gate Seal.....	10-22
10.6 Nozzle Tips	10-24
10.6.1 Checking the Height of a Nozzle Tip.....	10-24
10.7 Melt-Disk/Melt-Cube	10-25
10.7.1 Disassembling a Melt Link / Reverse Melt-Link.....	10-25
10.7.2 Re-assembling a Melt-Disk/Melt-Cube	10-25
10.7.2.1 Re-assembling a Melt-Disk/Melt-Cube with a Reverse Melt-Link...	10-25
10.8 Actuators.....	10-26
10.8.1 Extracting a Piston Top.....	10-28
10.8.1.1 HY65*, HY66*, HY67*, HY71*, HY87*, VPAC0008/9/10/11, HY-680SA/SAL and HY681SA/SAL, HY8400X/85/86AR/88, PN6400X/XAR, PN6410X/XAR, PN6400SA	10-28
10.8.1.2 PN2310x/PN2310xL and PN2310xAR/ PN2310xLAR.....	10-30
10.8.1.3 HY5500x/HY5500Xx/HY5500XxL.....	10-32
10.8.2 Extracting a Piston Bottom	10-33
10.8.2.1 HY65*, HY66*, HY67*, HY71*, HY87*, VPAC0008/9/10/11 ..	10-33
10.8.2.2 HY5500x/HY5500Xx/HY5500XxL.....	10-34
10.8.2.3 HY680SA/SAL and HY681SA/SAL.....	10-34

- 10.8.2.4 HY8400X/85/86AR/88, PN6400X/XAR,
PN6410X/XAR, PN6400SA 10-36
- 10.8.3 Extracting a Cylinder Body 10-37
 - 10.8.3.1 HY5500x/HY5500Xx/HY5500XxL, HY65*, HY66*, HY67*, HY71*,
HY87*, VPAC0008/9/10/11 10-37
 - 10.8.3.2 HY8400X/85/86AR/88, PN6400X/XAR,
PN6410X/XAR, PN6400SA 10-38
- 10.8.4 Extracting a Synchro Valve Pin..... 10-39
- 10.9 Extracting a Mag-Pin 10-42
- 10.10 Latches 10-46
 - 10.10.1 Latching a Cavity Plate to a Core Half (Cold Half)..... 10-46
 - 10.10.2 Latching a Cavity Plate to a Manifold Plate (Hot Half)..... 10-48

Section 11 - Troubleshooting 11-1

Section 12 - Glossary of Terms 12-1

Index I

Section 1 - Introduction

The purpose of this manual is to assist users in the integration, operation and maintenance of a Hot Runner. This manual is designed to cover most system configurations. If you need additional information specific to your system, or information in another language, please contact your representative or a Mold-Masters office.

1.1 Intended Use

Mold-Masters Hot Runner systems have been built to process thermoplastic material at the required temperature for injection molding and must not be used for any other purpose.

This manual is written for use by skilled persons who are familiar with injection molding machinery and their terminology. Operators should be familiar with plastic injection molding machines and the controls of such equipment. Maintenance persons should have sufficient understanding of electrical safety to appreciate the dangers of three-phase supplies. They should know how to take appropriate measures to avoid any danger from electrical supplies.

1.2 Documentation

This manual is part of the documentation package for your order and should be referenced along with the following documents included in the package:

- The Bill of Materials (BOM). Together with your general assembly drawing, the Bill of Materials should be referenced when ordering spare parts.
- General assembly drawing used to integrate your Hot Runner system into the mold.
- Hot Half drawing used to integrate Hot Half into cavity plate.
- CE declaration of conformity and declaration of incorporation (EU only)



NOTE

This manual should be used in conjunction with other relevant manuals; for example, the IMM manual and the controller manual.

1.2.1 User-Manual Release Details

When ordering this manual, please reference the document number below.

Table 1-1 User-Manual Release Details		
Document Number	Release Date	Version
HR-UM-EN-00-30-1	July 2019	30-1
HR-UM-EN-00-30-6	September 2020	30-6
HR--UM--EN--00--31-3	June 2021	31-3
HR--UM--EN--00--32	December 2022	32
UM--HR--ENG--32-1	October 2023	32-1
UM--HR--ENG--32-3	December 2024	32-3
UM--HR--ENG--33-1	December 2025	33-1
UM--HR--ENG--33-2	February 2026	33-2

1.3 Warranty

For current warranty information please refer to the documents available from our website www.moldmasters.com/support/warranty or contact your Mold-Masters representative.

1.4 Returned Goods Policy

Please do not return any parts to Mold-Masters without pre-authorization and a return authorization number supplied by Mold-Masters.

Our policy is one of continuous improvement and we reserve the right to alter product specifications at any time without giving notice.

1.5 Movement or Resale of Mold-Masters Products or Systems

This documentation is intended for use in the country of destination for which the product or system was purchased.

Mold-Masters takes no responsibility for documentation of products or systems if they are relocated or resold outside the intended country of destination, as stated on the accompanying invoice and/or waybill.

1.6 Copyright

© 2026 Mold-Masters (2007) Limited. All Rights Reserved. Mold-Masters® and the Mold-Masters logo are trademarks of Mold-Masters.

1.7 Units of Measure and Conversion Factors

The dimensions in this manual are from the original manufacturing drawings.

All values in this manual are in S.I. units or subdivisions of these units. Imperial units are given in parentheses immediately after the S.I. units.

Table 1-2 Units of Measure and Conversion Factors		
Unit	Abbreviation	Conversion value
bar	Bar	14.5 psi
in.	Inch	25.4 mm
kg	Kilogram	2.205 lb
kPa	Kilopascal	0.145 psi
lb	Pound	0.4536 kg
lbf	Pound force	4.448 N
lbf.in.	Pound force inch	0.113 Nm
min	Minute	
mm	Millimeter	0.03937 in.
mΩ	Milliohm	
N	Newton	0.2248 lbf
Nm	Newton meter	8.851 lbf.in.
psi	Pound per square inch	0.069 bar
psi	Pound per square inch	6.895 kPa
rpm	Revolutions per minute	
s	Second	
°	Degree	
°C	Degree Celsius	0.556 (°F -32)
°F	Degree Fahrenheit	1.8 °C +32

Section 2 - Global Support

2.1 Worldwide Locations

To find your nearest Mold-Masters office for sales or service support, please visit www.moldmasters.com/location-map or scan this QR code:



Section 3 - Safety

Please be aware that the safety information provided by Mold-Masters does not absolve the integrator and employer from understanding and following international and local standards for safety of machinery. It is the responsibility of the end integrator to integrate the final system, provide necessary e-stop connections, safety interlocks and guarding, to select the appropriate electrical cable for the region of use and to ensure compliance with all relevant standards.

It is the responsibility of the employer to:

- Properly train and instruct its personnel in the safe operation of equipment, including the use of all the safety devices.
- Provide its personnel with all necessary protective clothing, including a face shield and heat resistant gloves.
- Ensure the original and continuing competence of personnel caring for, setting up, inspecting and maintaining injection molding equipment.
- Establish and follow a program of periodic and regular inspections of injection molding equipment to ensure it is in safe operating condition and proper adjustment.
- Ensure that no modifications, repairs, or rebuild of portions are made to the equipment that reduces the level of safety existing at time of manufacture or remanufacture.

3.1 Overview



WARNING - READ MANUAL

Refer to all machine manuals and local regulations and codes for safety information.

The following safety hazards are most commonly associated with plastic injection molding equipment (see European Standard EN201 or American Standard ANSI/SPI B151.1).

Refer to the illustration of hazard areas below when reading the Table 3-1 Safety Hazards on page 3-3.

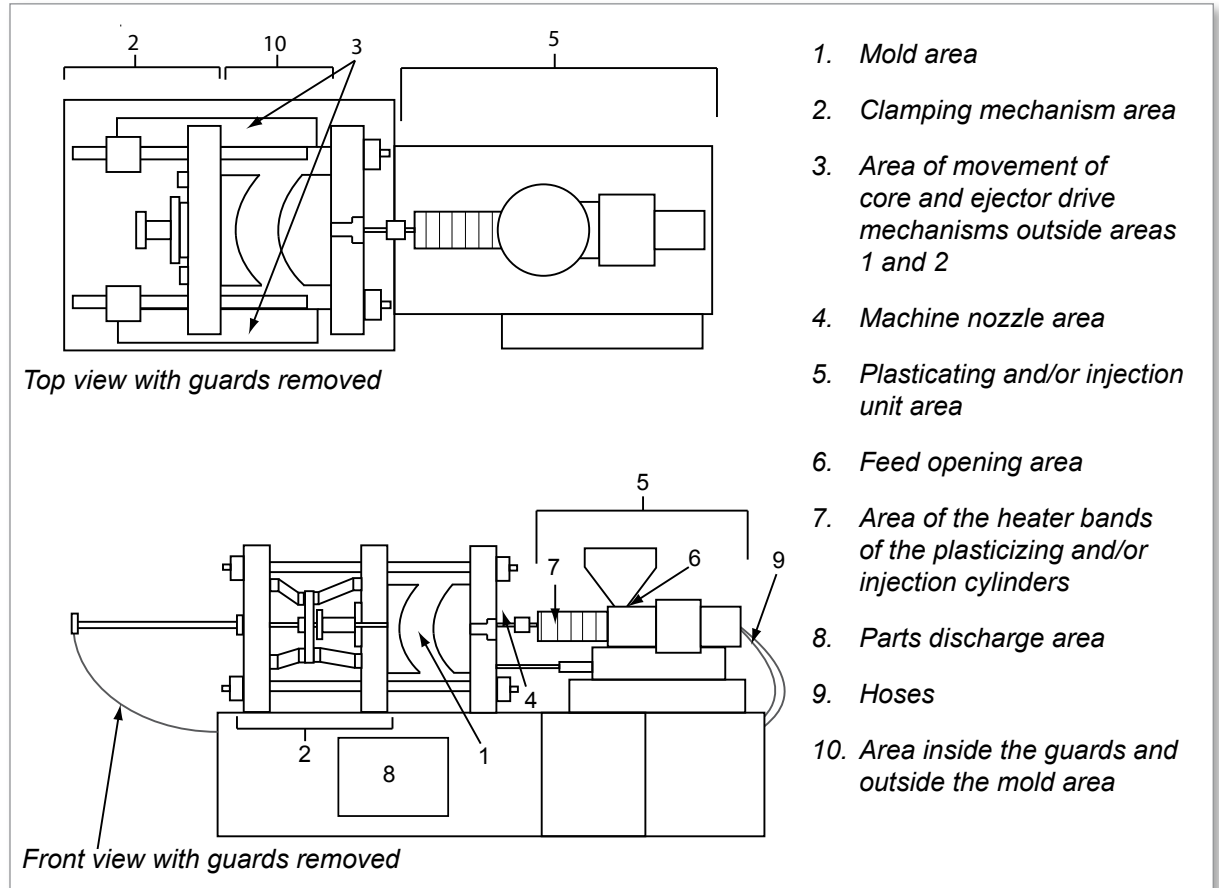


Figure 3-1 Injection molding machine hazard areas.

Table 3-1 Safety Hazards	
Hazard Area	Potential Hazards
<p>Mold Area Area between the platens. See Figure 3-1 area 1</p>	<p>Mechanical Hazards Crushing and/or shearing and/or impact hazards caused by:</p> <ul style="list-style-type: none"> • Movement of the platen. • Movements of the injection barrel(s) into the mold area. • Movements of cores and ejectors and their drive mechanisms. • Tie bar motion. <p>Thermal Hazards Burns and/or scalds due to operating temperature of:</p> <ul style="list-style-type: none"> • The mold heating elements. • Plasticized material released from / through the mold.
<p>Clamping Mechanism Area See Figure 3-1 area 2</p>	<p>Mechanical Hazards Crushing and/or shearing and/or impact hazards caused by:</p> <ul style="list-style-type: none"> • Movement of the platen. • Movement of the drive mechanism of the platen. • Movement of the core and ejector drive mechanism.
<p>Movement of Drive Mechanisms Outside the Mold Area and Outside the Clamping Mechanism Area See Figure 3-1 area 3</p>	<p>Mechanical Hazards Mechanical hazards of crushing, shearing and/or impact caused by the movements of:</p> <ul style="list-style-type: none"> • Core and ejector drive mechanisms.
<p>Nozzle Area The nozzle area is the area between the barrel and the sprue bushing. See Figure 3-1 area 4</p>	<p>Mechanical Hazards Crushing, shearing hazards, and/or impact hazards caused by:</p> <ul style="list-style-type: none"> • Forward movement of the plasticizing and/or injection unit including nozzle. • Movements of parts of the power operated nozzle shutoff and their drives. • Over pressurization in the nozzle. <p>Thermal Hazards Burns and or scalds due to operating temperature of:</p> <ul style="list-style-type: none"> • The nozzle. • Plasticized material discharging from the nozzle.
<p>Plasticizing and/or Injection Unit Area Area from the adapter / barrel head / end cap to the extruder motor above the sled including the carriage cylinders. See Figure 3-1 area 5</p>	<p>Mechanical Hazards Crushing, shearing and/or drawn-into hazards caused by:</p> <ul style="list-style-type: none"> • Unintentional gravity movements e.g. for machines with plasticizing and/or injection unit positioned above the mold area. • The movements of the screw and/or the injection plunger in the cylinder accessible through the feed opening. • Movement of the carriage unit. <p>Thermal Hazards Burns and or scalds due to operating temperature of:</p> <ul style="list-style-type: none"> • The plasticizing and/or injection unit. • The heating elements e.g. heater bands. • The plasticized material and/or vapors discharging from the vent opening, feed throat or hopper. <p>Mechanical and/or Thermal Hazard Hazards due to reduction in mechanical strength of the plasticizing and / or injection cylinder due to overheating.</p>

Table 3-1 Safety Hazards	
Hazard Area	Potential Hazards
Feed Opening See Figure 3-1 area 6	Pinching and crushing between injection screw movement and housing.
Area of the Heater Bands of the Plasticizing and/or Injection Cylinders See Figure 3-1 area 7	Burns and/or scalds due to operating temperature of: <ul style="list-style-type: none"> • The plasticizing and/or injection unit. • The heating elements e.g. heater bands. • The plasticized material and/or vapors discharging from the vent opening, feed throat or hopper.
Parts Discharge Area See Figure 3-1 area 8	Mechanical Hazards Accessible Through the Discharge Area Crushing, shearing and/or impact hazards caused by: <ul style="list-style-type: none"> • Closing movement of the platen. • Movements of cores and ejectors and their drive mechanisms. Thermal Hazards Accessible Through the Discharge Area Burns and or scalds due to operating temperature of: <ul style="list-style-type: none"> • The mold. • Heating elements of the mold. • Plasticized material released from/through the mold.
Hoses See Figure 3-1 area 9	<ul style="list-style-type: none"> • Whipping action caused by hose assembly failure • Possible release of fluid under pressure that can cause injury. • Thermal hazards associated with hot fluid.
Area Inside the Guards and Outside the Mold Area See Figure 3-1 area 10	Crushing and/or shearing and/or impact hazards caused by: <ul style="list-style-type: none"> • Movement of the platen. • Movement of the drive mechanism of the platen. • Movement of the core and ejector drive mechanism. • Clamp opening movement.
Electrical Hazards	<ul style="list-style-type: none"> • Electric shock or burns due to contact with live conductive parts. • Electrical or electromagnetic disturbance generated by the motor control unit. • Electrical or electromagnetic disturbance that can cause failures in the machine control systems and adjacent machine controls. • Electrical or electromagnetic disturbance generated by the motor control unit.
Hydraulic Accumulators	High pressure discharge.
Power Operated Gate	Crush or impact hazards caused by the movement of the power operated gates.
Vapors and Gases	Certain processing conditions and/or resins can cause hazardous fumes or vapors.

3.2 Operational Hazards



WARNINGS



- Refer to all machine manuals and local regulations and codes for safety information.
- The equipment supplied is subjected to high injection pressures and high temperatures. Ensure that extreme caution is observed in the operation and maintenance of the injection molding machines.
- Only fully trained personnel should operate or maintain equipment.
- Do not operate the equipment with unconfined long hair, loose clothing or jewelry, including name badges, neckties, etc. These may get caught in the equipment and can cause death or serious injury.
- Never disable or bypass a safety device.
- Ensure that the protective guards are placed around the nozzle to prevent the material from splashing or drooling.
- A burn hazard exists from material during routine purging. Wear heat-resistant personal protective equipment (PPE) to prevent burns from contact with hot surfaces or splatter of hot material and gases.
- Material purged from machine may be extremely hot. Ensure protective guards are in place around the nozzle to prevent material from splashing. Use proper personal protective equipment.
- All operators should wear personal protective equipment, such as face shields and use heat resistant gloves when working around the feed inlet, purging the machine or cleaning the gates of the mold.
- Remove purged material from the machine immediately.
- Decomposing or burning material could result in noxious gases being emitted from the purged material, feed inlet or mold.
- Ensure proper ventilation and exhaust systems are in place to help prevent inhalation of harmful gases and vapors.
- Consult the manufacturer's Material Safety Data Sheets (MSDS).
- Hoses fitted to the mold will contain high or low temperature fluids or air under high pressure. The operator must shut down and lockout these systems as well as relieving any pressure before performing any work with these hoses. Regularly inspect and replace all flexible hoses and restraints.
- Water and/or hydraulics on the mold may be in close proximity to electrical connections and equipment. Water leaks may cause an electrical short circuit. Hydraulic fluid leaks may cause a fire hazard. Always keep water and/or hydraulic hoses and fittings in good condition to avoid leaks.
- Never perform any work on the mold machine unless the hydraulic pump has been stopped.
- Check frequently for possible oil/water leaks. Stop the machine and make repairs if you find a leak.

**WARNING**

- Make sure that the cables are connected to the correct motors. Cables and motors are clearly labeled. Reversing the cables can result in unexpected and uncontrolled motion causing a safety risk or damage to the machine.
- A crushing hazard exists between the nozzle and mold melt inlet during carriage forward motion.
- A possible shearing hazard exists between the edge of the injection guard and the injection housing during injection.
- The open feed port could present a hazard to a finger or a hand inserted during operation of the machine.
- The electric servo motors could overheat presenting a hot surface which could cause burns to someone touching it.
- The barrel, barrel head, nozzle, heater bands and mold components are hot surfaces which could result in burns.
- Keep flammable liquids or dust away from the hot surfaces as they could ignite.
- Follow good housekeeping procedures and keep floors clean to prevent slips, trips and falls due to spilled material on the work floor.
- Apply engineering controls or hearing conservation programs as necessary to control noise.
- When doing any work on the machine that requires moving and lifting the machine, ensure that lifting equipment (eyebolts, fork lift truck, cranes, etc.) will have sufficient capacity to handle mold, auxiliary injection unit or Hot Runner weight.
- Connect all lifting devices and support the machine using a crane of adequate capacity before commencing work. Failure to support the machine can result in severe injury or death.
- Mold cable from the controller to the mold must be removed before servicing the mold.

3.3 General Safety Symbols

Table 3-2 Typical Safety Symbols	
Symbol	General Description
	General – Warning Indicates an immediate or potentially hazardous situation, which if not avoided, could result in a serious injury or death, and/or damage to equipment.
	Warning – Barrel Cover Grounding Strap Lockout/tagout procedures must be followed before removing the barrel cover. Barrel cover can become energized upon removal of grounding straps and contact can result in death or serious injury. Grounding straps must be reconnected before reconnecting power to machine.
	Warning – Crushing and/or Impact Points Contact with moving parts can cause serious crushing injury. Always keep guards in place.
	Warning – Crush Hazard Closing Mold
	Warning – Hazardous Voltage Contact with hazardous voltages will cause death or serious injury. Turn off power and review electrical schematics before servicing equipment. May contain more than one live circuit. Test all circuits before handling to make sure circuits have been de-energized.
	Warning – High Pressure Overheated fluids may cause severe burns. Discharge pressure before disconnecting water lines.
	Warning – High Pressure Accumulator Sudden release of high pressure gas or oil can cause death or serious injury. Discharge all gas and hydraulic pressure before disconnecting or disassembling accumulator.
	Warning – Hot Surfaces Contact with exposed hot surfaces will cause serious burn injury. Wear protective gloves when working near these areas.
	Mandatory – Lockout/tagout Ensure that all energies are properly locked out, and remain locked out until the service work is completed. Servicing equipment without disabling all internal and external power sources can cause death or serious injury. De-energize all internal and external power sources (electrical, hydraulic, pneumatic, kinetic, potential, and thermal).
	Warning – Material Splashing Hazard Material or high pressure gas can cause death or severe burns. Wear personal protective equipment while servicing the feed throat, nozzle, mold areas, and when purging the injection unit.
	Warning – Read Manual Before Operation Personnel should read and understand all instructions in the manuals before working on equipment. Only properly trained personnel should operate the equipment.
	Warning – Slip, Trip or Fall Hazard Do not climb on equipment surfaces. Serious slip, trip or fall injuries can result from personnel climbing on equipment surfaces.

Table 3-2 Typical Safety Symbols	
Symbol	General Description
	Caution Failure to follow instructions may damage equipment.
	Information Indicates additional information or a reminder.

3.4 Wiring Check



CAUTION

Failure to do wiring or connections properly will result in equipment failure.

System Mains Supply Wiring:

- Before connecting the system to a power supply, it is important to check that the wiring between the system and the power supply has been done correctly.
- Particular attention must be given to the current rating of the power supply. For example, if a controller is rated at 63A, then the power supply must also be rated at 63A.
- Check that the phases of power supply are wired correctly.

Controller to Mold Wiring:

- For separate power and thermocouple connections, ensure that the power cables are never connected to the thermocouple connectors and vice-versa.
- For mixed power and thermocouple connections, ensure that the power and thermocouple connections have not been wired incorrectly.

Communications Interface and Control Sequence:

- It is the customer’s responsibility to verify functionality of any custom machine interface at safe speeds, prior to operating equipment in the production environment at full speed in automatic mode.
- It is the customer’s responsibility to verify all required motion sequences are correct, prior to operating equipment in the production environment at full speed in automatic mode.

Switching the machinery into Auto mode without having verified the control interlocks and motion sequence are correct, may cause damage to machinery and/or equipment.

The use of Mold-Masters standard connections can help to eliminate the potential for wiring errors.

Mold-Masters *Ltd.* cannot be responsible for damage caused by customer wiring and/or connection errors.

3.5 Lockout Safety



WARNING - ELECTRICAL HAZARD

Do not enter the cabinet without first isolating the power supplies.

All maintenance should be performed by properly trained personnel based on local laws and regulation. Electrical products may not be grounded when removed from the assembled or normal operating condition.

Ensure proper grounding of all electrical components before performing any maintenance to avoid potential risk of electrical shock.

Often power sources are inadvertently turned on or valves are opened mistakenly before maintenance work is completed, resulting in serious injuries and fatalities. Therefore, it is important to ensure that all energies are properly locked out and that they remain locked out until the work is completed.

High voltage and amperage cables are connected to the controller and the mold. Electrical power must be shut off and lockout/tagout procedures followed prior to installing or removing any cables.

Use lockout/tagout to prevent operation during maintenance. If a lockout is not performed, uncontrolled energies could cause:

- Electrocution from contact with live circuits
- Cuts, bruises, crushing, amputations or death, resulting from entanglement with belts, chains, conveyors, rollers, shafts, impellers
- Burns from contact with hot parts, materials or equipment such as furnaces
- Fires and explosions
- Chemical exposures from gases or liquids released from pipelines

3.5.1 Electrical Lockout



WARNING - READ MANUAL

Refer to all machine manuals and local regulations and codes.



WARNING - LOCKOUT/TAGOUT

Make sure that all power sources feeding the equipment are locked out.

Employers must provide an effective lockout/tagout program.

1. Shut down machine using normal operational shutdown procedure and controls. This should be done by, or in consultation with the machine operator.
2. After ensuring that the machinery has been completely shut down, and all controls in the “off” position, open the main disconnect switch located in the field.
3. Using your own personal padlock, or one assigned by your supervisor, lock the disconnect switch in the off position. Do not lock only the box. Remove the key and retain. Complete a lockout tag and affix to the disconnect switch. Each person working on the equipment must follow this step. The lock of the person doing the work or in charge must be installed first, remain throughout and be removed last. Test the main disconnect switch and make sure it cannot be moved to the “on” position.
4. Try to start the machine using the normal operation controls and point of operation switches to make sure that the power has been disconnected.
5. Other sources of energy that could create a hazard while working on the equipment must also be de-energized and appropriately “locked-out”. This can include gravity, compressed air, hydraulics, steam and other pressurized or hazardous liquids and gases. See Table 3-3.
6. When the work is completed, prior to removing the last lock, make sure the operational controls are in the “off” position so that the main disconnect switching is done under “no load”. Ensure all blocks, tools and other foreign materials are removed from machine. Also ensure that all personnel that may be affected are informed that the lock(s) will be removed.
7. Remove lock and tag, and close the main disconnect switch if permission has been given.
8. When the work has not been completed on the first shift, the next operator should install a personal lock and tag before the first operator removes the original lock and tag. If the next operator is delayed, a lock and tag could be installed by the next supervisor. Lockout procedures should indicate how the transfer is to be conducted.
9. It is important that, for their personal protection, each worker and/or fore person working in or on a machine places his/her own safety lock on the disconnect switch. Use tags to spotlight work in progress and give details of work being done. Only when the work is completed and the work permit signed off, may each worker remove his/her lock. The last lock to be removed should be that of the person supervising the lockout and this responsibility should not be delegated.

© Industrial Accident Prevention Association, 2008.

3.5.2 Energy Forms and Lockout Guidelines

Table 3-3 Energy Forms, Energy Sources and General Lockout Guidelines		
Energy Form	Energy Source	Lockout Guidelines
Electrical Energy	<ul style="list-style-type: none"> • Power transmission lines • Machine power cords • Motors • Solenoids • Capacitors (stored electrical energy) 	<ul style="list-style-type: none"> • Turn off power at machine first (i.e., at point of operation switch), and then at the main disconnect switch for the machine. • Lock and tag the main disconnect switch. • Fully discharge all capacitive systems (e.g., cycle machine to drain power from capacitors) according to the manufacturer's instructions.
Hydraulic Energy	<ul style="list-style-type: none"> • Hydraulic systems (e.g., hydraulic presses, rams, cylinders, hammers) 	<ul style="list-style-type: none"> • Shut off, lock (with chains, built-in lockout devices, or lockout attachments) and tag valves. • Bleed off and blank lines as necessary.
Pneumatic Energy	<ul style="list-style-type: none"> • Pneumatic systems (e.g., lines, pressure reservoirs, accumulators, air surge tanks, rams, cylinders) 	<ul style="list-style-type: none"> • Shut off, lock (with chains, built-in lockout devices, or lockout attachments) and tag valves. • Bleed off excess air. • If pressure cannot be relieved, block any possible movement of machinery.
Kinetic Energy (Energy of a moving object or materials. Moving object may be powered or coasting)	<ul style="list-style-type: none"> • Blades • Flywheels • Materials in supply lines 	<ul style="list-style-type: none"> • Stop and block machine parts (e.g. stop flywheels and ensure that they do not recycle). Review entire cycle of mechanical motion and ensure that all motions are stopped. • Block material from moving into area of work. • Blank as required.
Potential Energy (Stored energy that an object has the potential to release due to its position)	<ul style="list-style-type: none"> • Springs (e.g., in air brake cylinders) • Actuators • Counterweights • Raised loads • Top or movable part of a press or lifting device 	<ul style="list-style-type: none"> • If possible, lower all suspended parts and loads to the lowest (rest) position. • Block parts that might be moved by gravity. • Release or block spring energy.
Thermal Energy	<ul style="list-style-type: none"> • Supply lines • Storage tanks and vessels 	<ul style="list-style-type: none"> • Shut off, lock (with chains, built-in lockout devices, or lockout attachments) and tag valves. • Bleed off excess liquids or gases. • Blank lines as necessary.

3.6 Disposal

Mold-Masters declines any responsibility for personal injury or personal damage arising from reuse of the individual components, if these parts are used other than for the original and proper intended purpose.

1. Disconnect the Hot Runner and system components from the power supply fully and properly before disposal (electricity, hydraulics, pneumatics and cooling).
2. Ensure that the system to be disposed of is free from fluids. In the case of hydraulic needle valve systems, drain the oil from the lines and cylinders and dispose it in an environmentally responsible manner.
3. Dismantle the electrical components, separate them according to environmental standards, and dispose of hazardous waste if necessary.
4. Remove the wiring. The electronic components are to be disposed in accordance with the national electric scrap ordinance.
5. Recycle the metal parts (waste metal and scrap trade). Follow the instructions of the relevant waste disposal company.

Recycling of the materials should be prioritized during the disposal process.

3.7 Hot Runner Safety Hazards



WARNING

- The equipment supplied is subjected to high injection pressures and high temperatures.
- Ensure that extreme caution is observed in the operation and maintenance of the Hot Runner system and the injection molding machines.
- Do not operate the equipment with unconfined long hair, loose clothing or jewelry, including name badges, neckties, etc. These may get caught by the moving belt mechanism and can cause death or serious injury.
- Never disable or bypass a safety device.
- All operators should wear personal protective equipment, such as face shields, and use heat resistant gloves when working around the feed throat, purging the machine or cleaning the gates of the mold.
- Check frequently for possible oil or water leaks. Stop the machine and make repairs.
- Do not look directly into the feed throat of a hopper. Unexpected release of resin may cause serious burns. Use a mirror. Failure to do so may cause serious injury.
- Remove purgings from the machine immediately. Never directly handle plastic purgings or drool until they have completely cooled. Purgings may appear solid but may still be hot and cause serious injury.
- Some plastics develop gases that may be dangerous to personal health. Follow the plastics supplier's recommendations. Review their material safety data sheet. Ensure the molding area is well ventilated.
- Never touch or inspect the timing belt when power is on and motor and controller are connected. Unplug the controller before any maintenance.
- Always cover E-Drive belt area / molding machine drop out area / bench top with a proper protective cover before any bench test or in-mold testing.
- High voltage and amperage cables are connected to the controller (220 VAC). There is also a high voltage cable connection between the servo motor and controller.
- Always unplug the controller before performing any maintenance work.
- Hoses fitted to the mold will contain high or low temperature fluids or air under high pressure. The operator must shut down and lockout these systems as well as relieving any pressure before performing any work with these hoses.
- Never perform any work on the mold unless the hydraulic pump has been stopped.
- High voltage and amperage cables are connected to the mold. Electric power must be shut off prior to installing or removing any cables.

**WARNING**

- Water and/or hydraulics on the mold may be in close proximity to electrical connections and equipment. Water leaks may cause an electrical short circuit. Hydraulic fluid leaks may cause a fire hazard. Always keep water and/or hydraulic hoses and fittings in good condition to avoid leaks.
- Make sure the lifting eyebolt, lifting chain and crane are rated to adequately support the weight of the plate(s). Failure to do so can cause a serious injury.
- All maintenance on Mold-Masters products should be performed by properly trained personnel based on local law or regulation requirements.
- Ensure proper grounding of all electrical products before performing any maintenance to avoid potential risk of electrical shock.
- Make sure the machine has been locked out and tagged out in accordance to the machine's documented procedures. Failure to do so may lead to serious injury or death.
- Check that all coolant, hydraulic and air lines as well as electrical cables will not interfere with the moving parts of the mold, machine or robot. The lines must be of sufficient length so that they will not strain or pinch when the mold halves separate.
- For water cooling nozzle jacket, coolant must be maintained with the proper mixture to prevent corrosion and circuit blockage.
- Care must be taken to ensure the nozzle terminal ends do not come in contact with the hydraulic fluid. The nozzles may short out or become damaged.
- Do not mix electrical power cables with thermocouple extension cables. They are not designed to carry the power load or list accurate temperature readings in each other's application.

All Mold-Masters heated components are manufactured to standards that ensure safe and reliable operation provided that the following precautions are met:

- To maximize heater element and component life, the temperature must be controlled and maintained within safe operating limits. Mold-Masters strongly recommends individual control of each heated component, including heater plates, with a reliable temperature controller that includes soft-start protection.
- Always operate the system using correctly installed "J" type thermocouples connected to a reliable temperature controller with soft-start protection.
- Avoid running the system for long periods on manual control.
- Use caution when applying power in manual mode. Use minimum heat required for the process to avoid overheating and possible damage to components.
- Always replace pinched or damaged thermocouples.
- When grouping heated components together and controlling more than one load from a single thermocouple, make sure that the components are of similar material, wattage, size and are exposed to the same thermal conditions.
- When replacing heater plates or other heated components always replace with Mold-Masters components of the same type and install as originally specified on Mold-Masters general assembly drawings

Section 4 - Preparation



WARNING - READ MANUAL

Read Section 3 - Safety on page 3-1 before unpacking, cleaning, or assembling parts of the Hot Runner system.

The following section is a step-by-step guide to prepare your Mold-Masters system for use.

4.1 Tools Required

Depending on the size and complexity of your Hot Runner system, you will require most of the tools and materials listed below.

- Allen keys: Depending on system, set of metric or imperial size keys to use 4, 5, 6, 8 and 10 mm (0.16, 0.20, 0.24, 0.31 and 0.39 in.) on cap screws
- Nickel based anti-seize compound: to prevent oxidation of screw threads that could cause screws to seize with high temperatures
- Solvents (denatured alcohol): for removal of rust inhibitors
- Calibrated torque wrench: for consistent screw pressure throughout the system
- Pliers: for general assembly work
- Circlip pliers: to remove and install circlip in valve systems
- Micrometer: 0-150 mm (0-5.9 in.) to check system part and plate thickness
- Depth micrometer: to check bore depths
- Slot head screw driver: used in installing thermocouples and ground wires
- Slot head screw driver (small): used in fastening electrical wires to connectors
- Crimping tool: for fastening connector pins when necessary
- Wire strippers: for preparing wires
- Utility knife: for cutting tape, wires etc.
- Glass tape: for grouping wires into zones
- Dye spotting blue compound: for checking face contact
- Sockets
- Lapping compound for valve gate systems
- Plastic face hammer
- Proper actuator installation / extraction tools



Figure 4-1 Toolkit required

4.2 Screws

4.2.1 Length



WARNING - SHEARING HAZARD

Do not shorten the mounting screws. Failure to obey may cause serious injury or death.

When a manifold is heated the metal expands, stretching the mounting screws; if screw lengths are shortened, there is a possibility of shearing. The expansion factor is calculated into the length of each screw.



CAUTION - SHEARING HAZARD

Do not shorten the screws. Failure to obey may cause damage to parts.

The use of an incorrect size, length and grade of screw could cause the screw to shear, fatigue, or stretch beyond its yield point, resulting in expensive downtime of the Hot Runner.

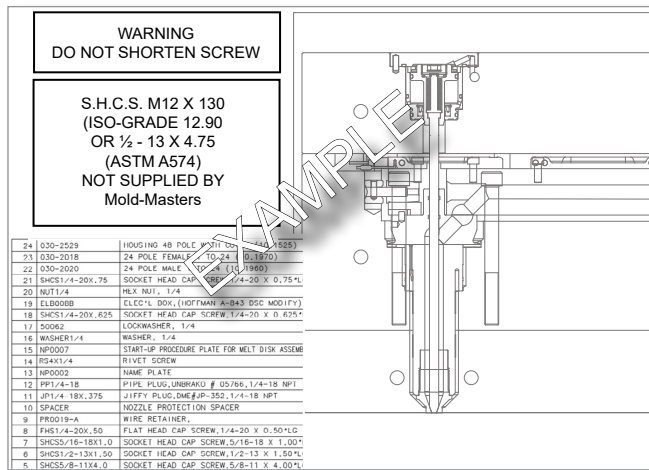


Figure 4-2 Screw length

4.2.2 Grade

All system and hot half screws must be grade 12.9. The use of an incorrect size, length, and grade of screw could cause the screw to shear, fatigue, or stretch beyond its yield point, resulting in expensive downtime of the hot runner.

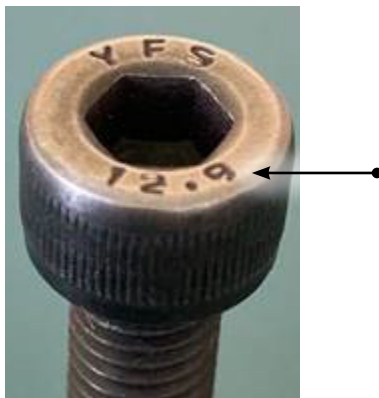


Figure 4-3 Screw grade

Some screws show the grade on the part. Make sure that the correct grade of screw is used.

4.3 Tighten Settings



CAUTION

Tighten the gate seals are at room temperature and then re-tighten at processing temperature to the specified torque value. Failure to do so may cause leaks from the gate seal.



CAUTION

Compare the torque values in the following tables with the torque values on your general assembly drawing. Failure to use the correct torque may cause damage to parts.

4.3.1 Master-Series Gate Seals

Table 4-1 Tightens of Master-Series Gate Seals			
Product Line	Product Size	Tighten (ft-lb)	Tighten (N·m)
Master Series	Femto Lite	6-7	8-9
	Femto	6-7	8-9
	Pico	12-13	16-18
	Centi	20-22	27-30
	Deci	25-28	34-38
	Hecto	35-40	47-54

4.3.2 Summit-Series Gate Seals

Table 4-2 Tightens of Summit-Series Gate Seals			
Product Line	Product Size	Tighten (ft-lb)	Tighten (N·m)
Summit Series	Femto	6-7	8-9
	Pico	12-13	16-18
	Centi	20-22	27-30

4.3.3 Others

Tighten sequence and step torquing: We recommend that system screws be tightened in a standard bolt pattern and that the specified torque be achieved in three steps (1/3, 2/3 and full torque).

Bridge manifold mounting screws should be tightened 1/3 higher than the torque specified on your general assembly drawings.

For systems with Master-Shield, tighten the system screws from the center outward to exert an even load across all screws during assembly. Tighten the screws to the specified torque in a minimum of two steps.

The quality and the length of screws are specified on Mold-Masters general assembly drawings.

Table 4-3 Tightens of System Assembly Screws			
Metric	Tighten Setting (N·m)	Imperial	Tighten Setting (ft-lb)
M5	7	#10-32	5
M6	14	1/4-20	10
M8	20	5/16-18	15
M10	40	3/8-16	30
M12	60	1/2-13	45
M16	145	5/8-11	107
M20	285	3/4-10	210

Table 4-4 Tightens of Plate Assembly Screws			
Metric	Tighten Setting (N·m)	Imperial	Tighten Setting (ft-lb)
M5	9	#10-32	5
M6	15	1/4-20	12
M8	36	5/16-18	24
M10	72	3/8-16	44
M12	125	1/2-13	106
M16	311	5/8-11	212
M20	606	3/4-10	377

Table 4-5 Component Tighten Settings	
Component	Tighten Setting
Piston Top (for Valve Actuator—Series 5500, 6500, 6600 and 6700)	20-27 N·m (15-20 ft-lbs)

4.4 Unpacking



WARNING - CRUSH HAZARD

Make sure the lifting eyebolt, lifting chain and crane are rated to adequately support the weight. Failure to do so can cause a serious injury or death.

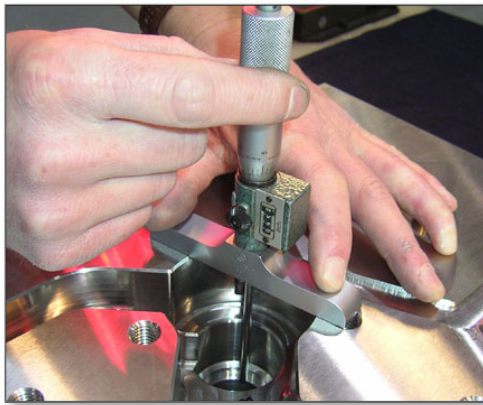


WARNING - LOCKOUT/TAGOUT

Make sure the machine has been locked out and tagged out in accordance to the machines documented procedures. Failure to do so may cause serious injury or death.

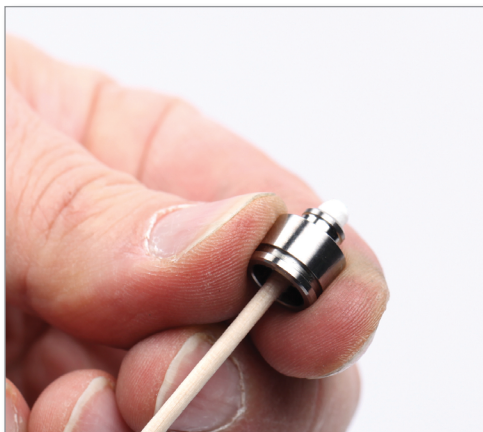
Carefully remove all components from the shipping box and check that all components listed on the packing slip were supplied.

1. Check that all mold base dimensions are correct and correspond to Mold-Masters general assembly drawings.



4.5 Cleaning

1. All nozzles, manifolds and Hot Runner components must be free of the rust inhibitor applied at the factory.
2. Disassemble the system.
3. Wipe down the nozzle body.
4. Remove the part and wipe clean.
5. If necessary, use a cotton swab to clean narrow interior surfaces or screw threads. For large surfaces such as mold plates, use thinner in spray form to clean channels and recesses.



4.6 Overview of System Types

The following pages are to be used as a general guide to assist in identifying components. Refer to your general assembly drawings for specific component lists. If your system does not match these systems, please refer to other speciality systems mentioned within the manual for additional information.

4.6.1 Non-Valved System

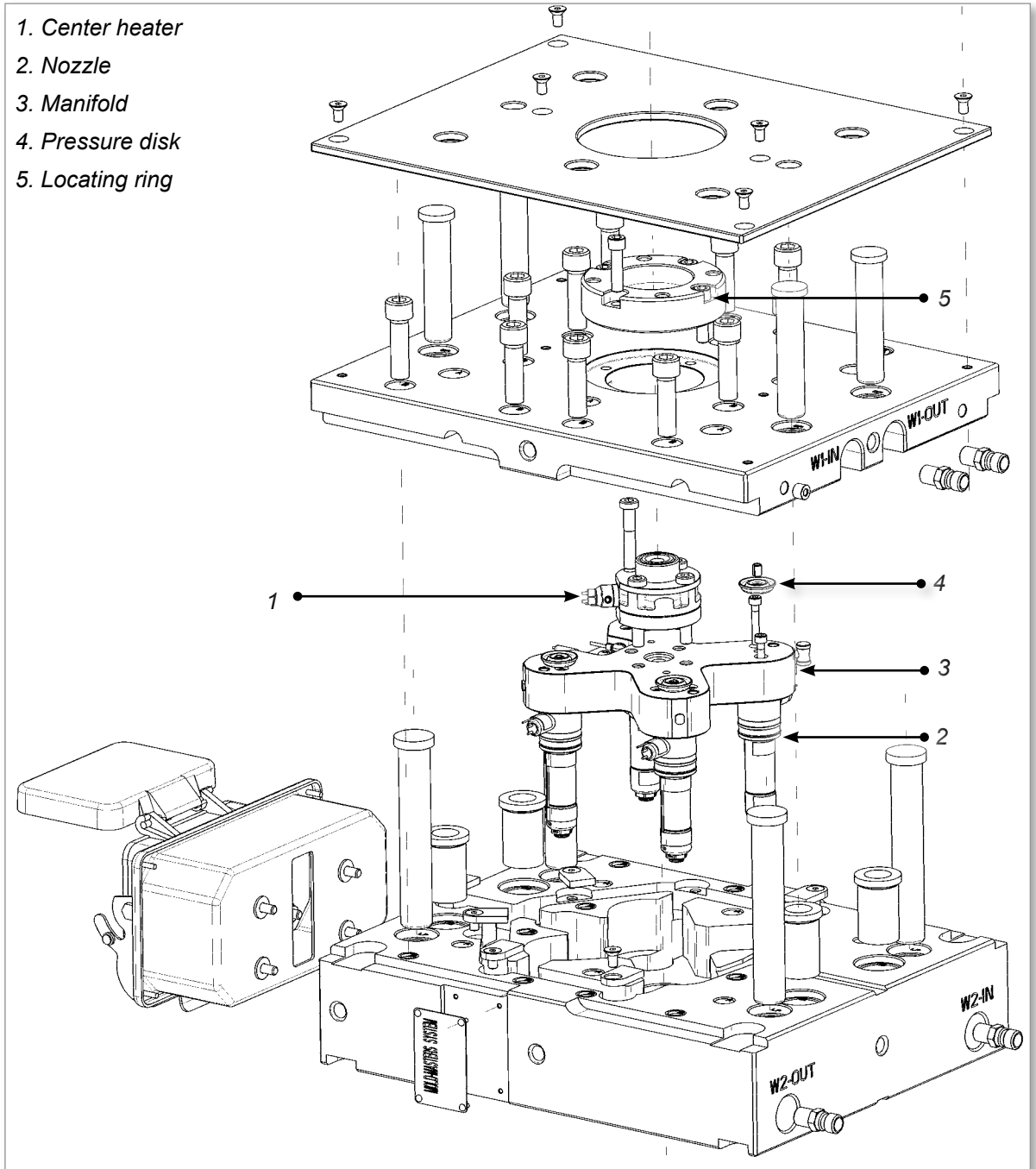


Figure 4-4 Non-valved System

4.6.2 Valve Gate System

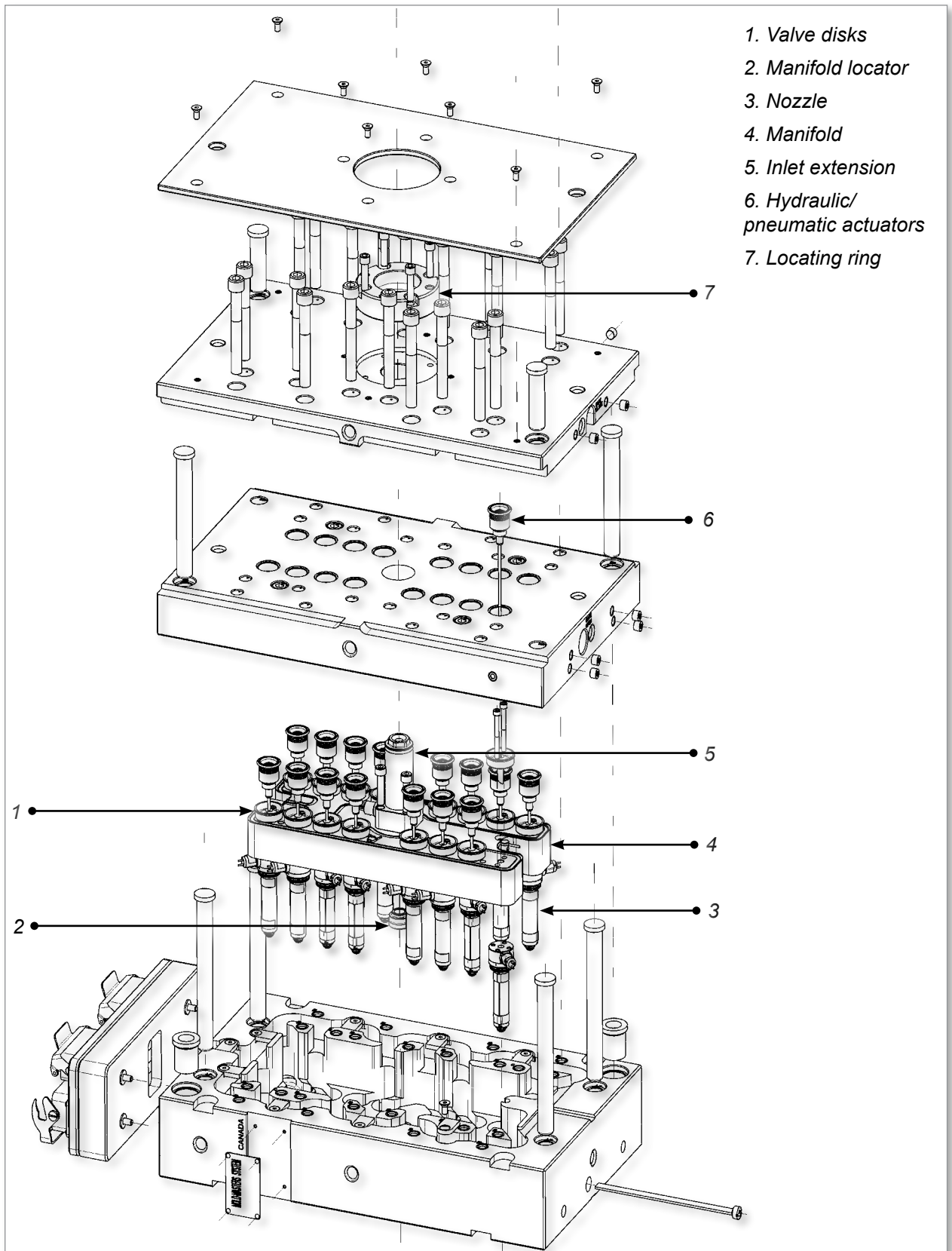


Figure 4-5 Valve Gate System

4.6.3 Valve Gate System with Bridge

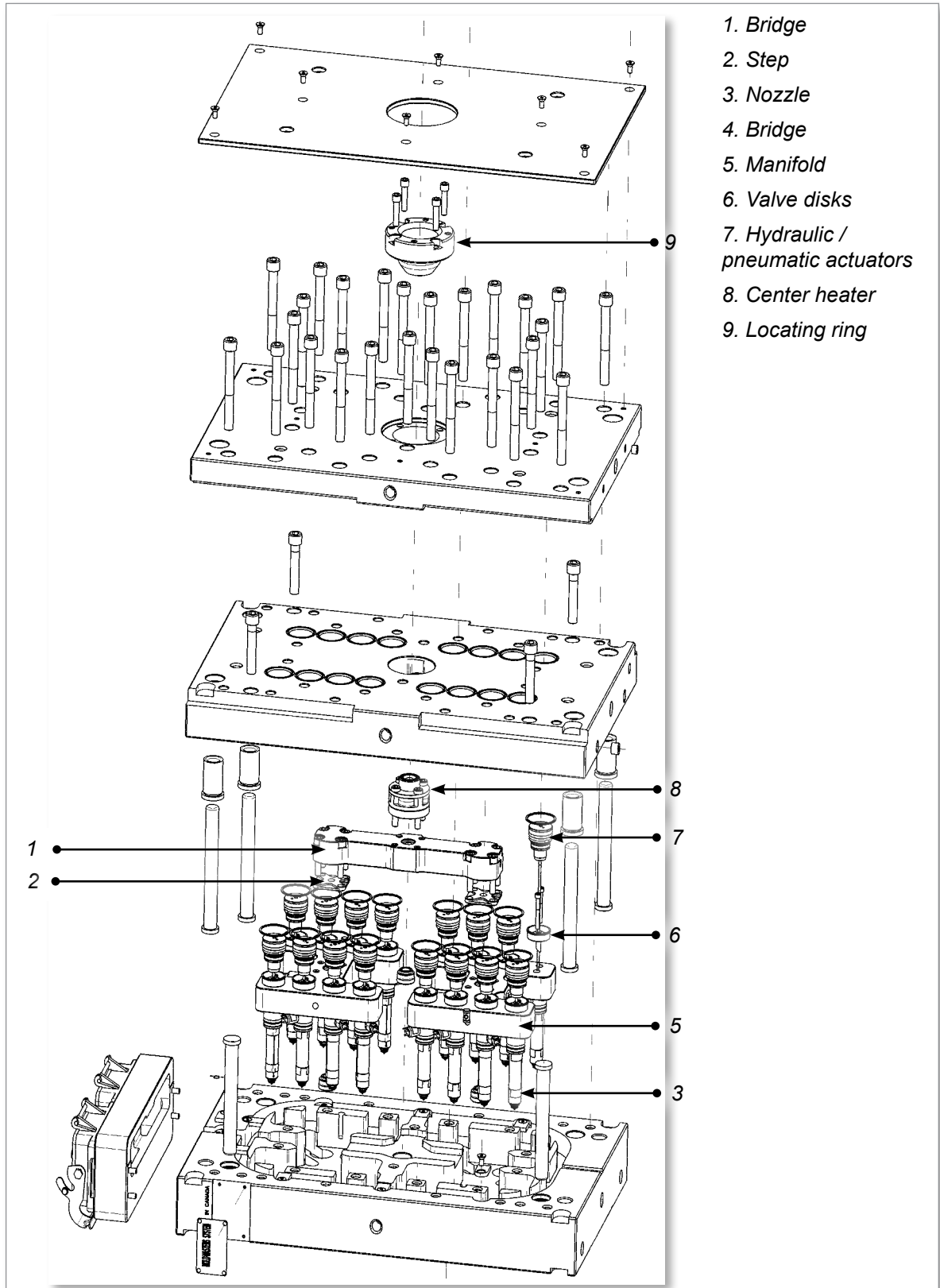
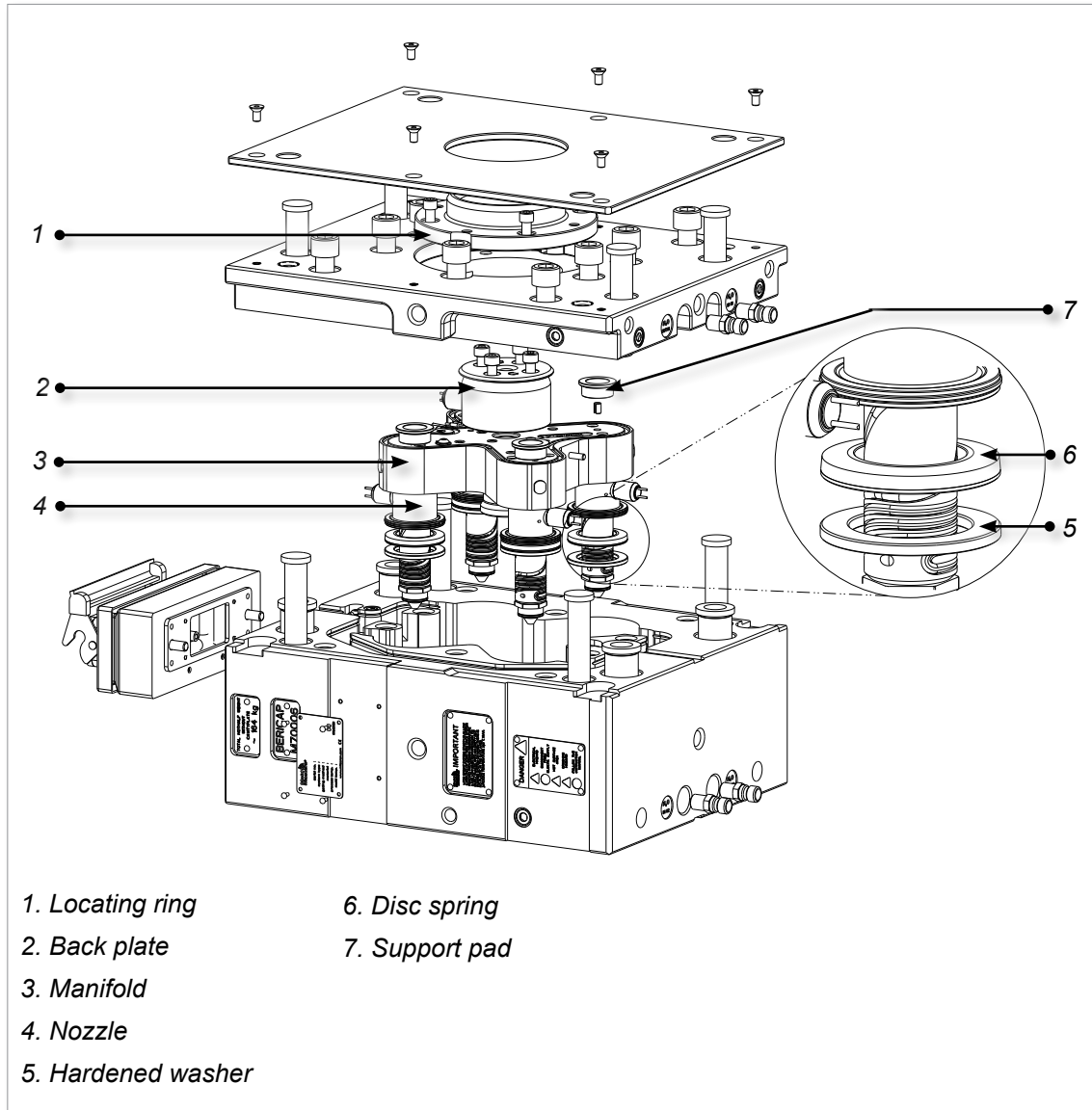


Figure 4-6 Valve Gate System with Bridge

4.6.4 Non-Valved System with Master-Shield Technology

Figure 4-7 highlights the Master-Shield components within a thermal-gate brazed system.



- 1. Locating ring
- 2. Back plate
- 3. Manifold
- 4. Nozzle
- 5. Hardened washer
- 6. Disc spring
- 7. Support pad

Figure 4-7 Non-Valved System with Master-Shield Technology

4.6.5 Valved System with Master-Shield Technology

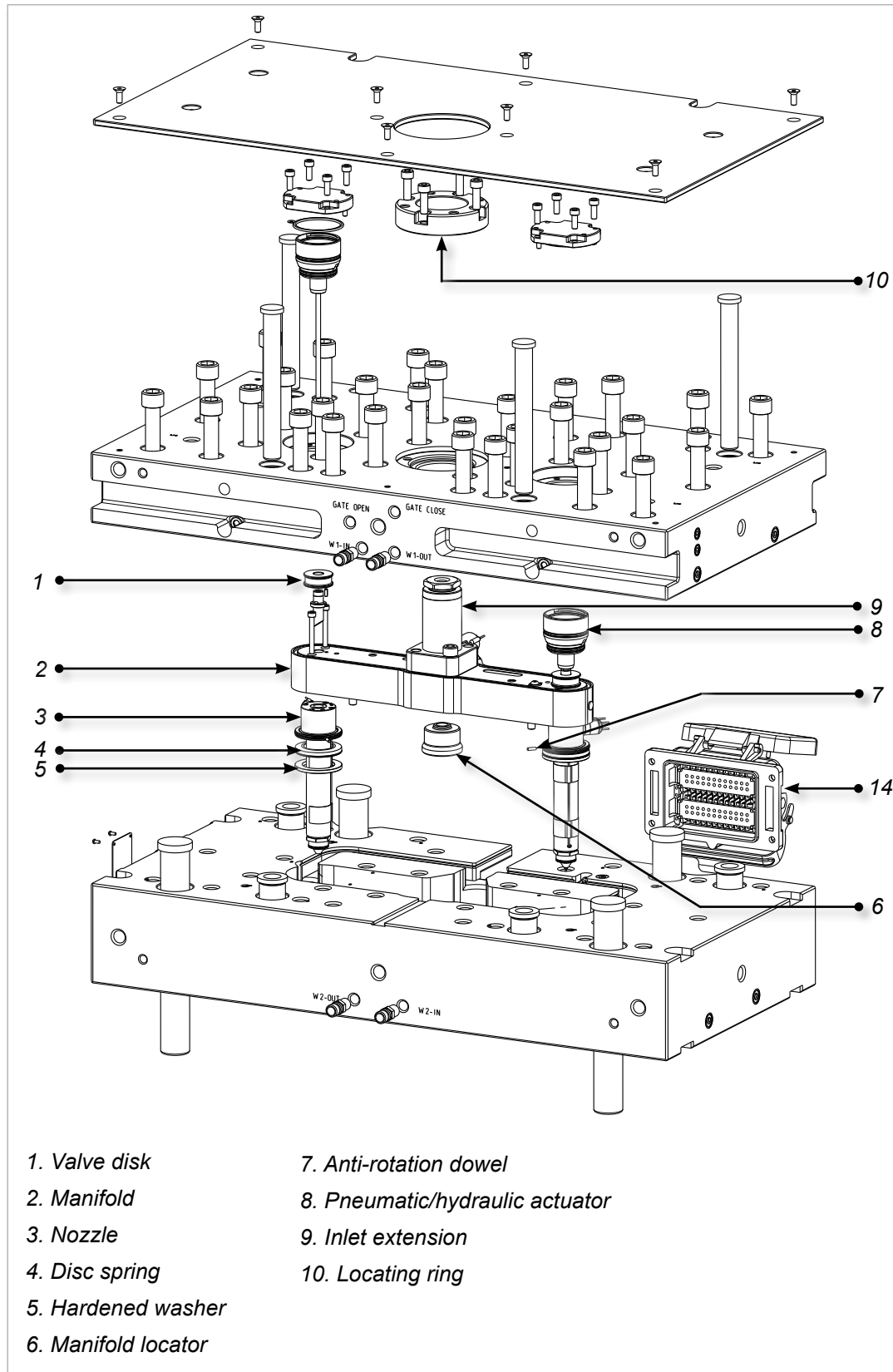


Figure 4-8 Pneumatic/hydraulic system with Master-Shield technology

4.7 System Cutaways

This section is a step-by-step guide to assembling your Mold-Masters Hot Runner system.

4.7.1 Brazed-in/Paste-in System

This illustration of a typical Mold-Masters cast-in Hot Runner system is divided into two halves: valve side and non-valve side. The terminology associated with the various components and features are listed below.

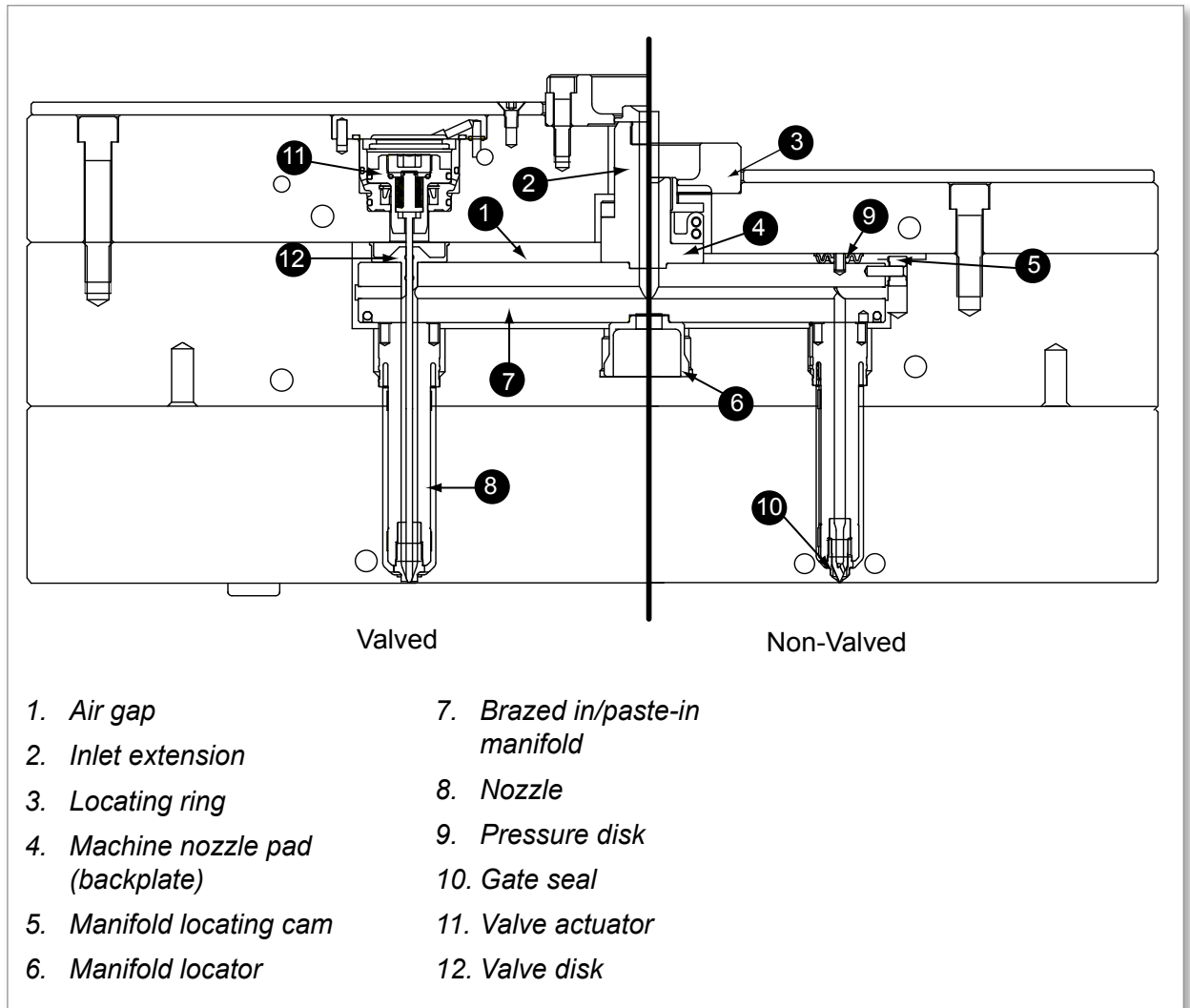


Figure 4-9 Cutaway of brazed-in/paste-in system

4.7.2 Bolt-in System

This illustration of a typical Mold-Masters bolt-in Hot Runner system is divided into two halves: the valve side and the non-valve side. The terminology associated with the various components and features are listed below.

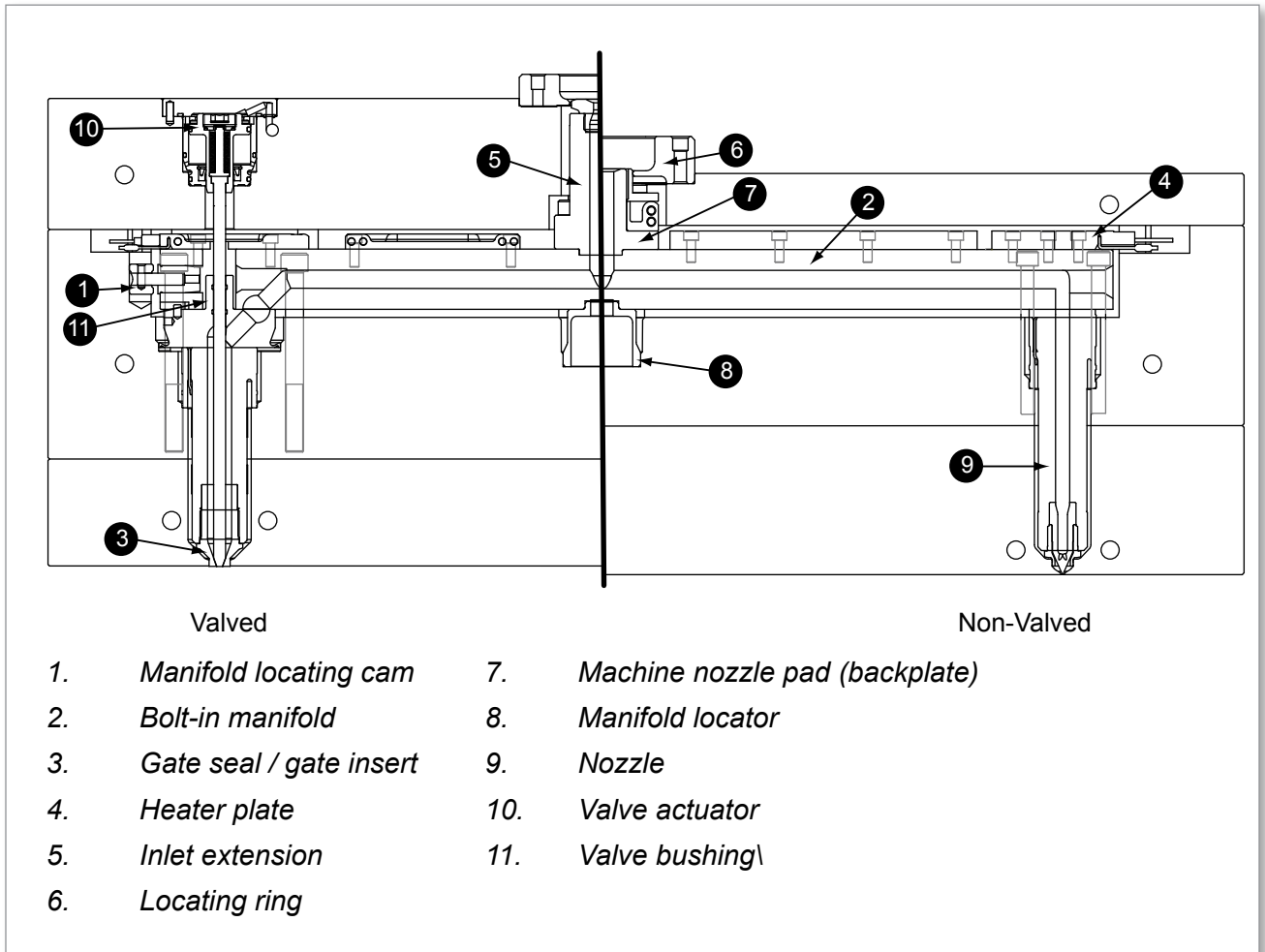


Figure 4-10 Cutaway of a bolt-in system

4.7.3 Master-Shield System

This illustration of a typical Mold-Masters Master-Shield cast-in system is divided into two halves: the valve side and the non-valve side. The terminology associated with the various components and features are listed below.

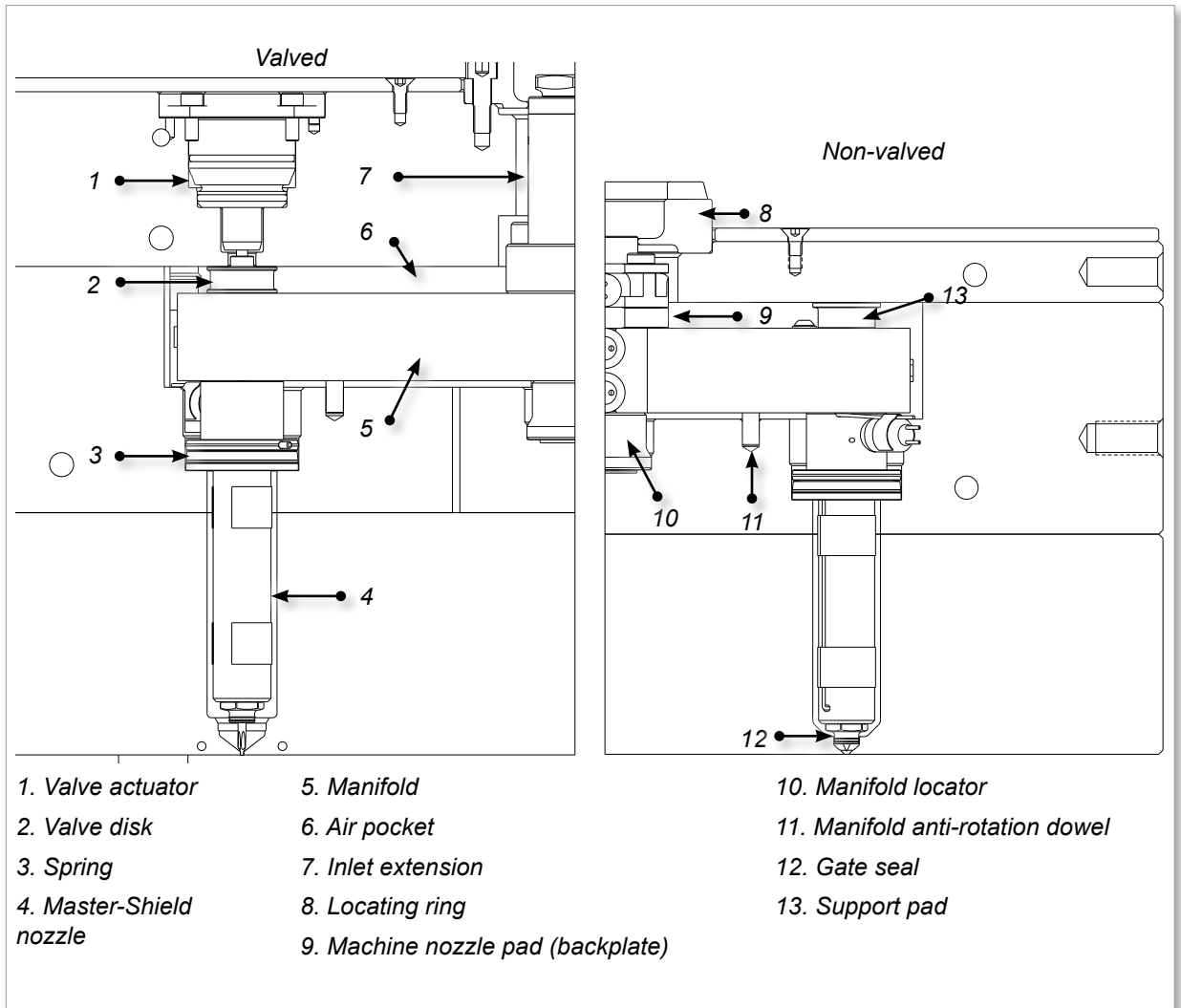


Figure 4-11 Cutaway of a Master-Shield cast-in system

Section 5 - Assembly



WARNING - READ MANUAL

Read Section 3 - Safety on page 3-1 before assembling parts of the Hot Runner system.

5.1 Finishing a Gate Seal

Most nozzles are supplied with the gate seal installed except when the seal requires final machining by a toolmaker, such as with the hot valve or hot sprue.

The gate seals supplied with your system may need to be adjusted to tolerances based on the material grade and cooling in the cavity. Refer to your Mold-Masters general assembly Gate Detail drawing to determine if gate seal finishing is required. Refer to your general assembly drawing to determine which gating method applies.

5.2 Installing a Water-Cooled Gate Insert

Your system may not include a water-cooled gate insert. Refer to your general assembly drawing.

The water-cooled gate insert will require final machining by tool maker.

1. Machine the gate well and nozzle well details.
2. Finish to final height and to correct guiding diameter, if required. Refer to your system drawing for details.
3. Clean the insert-seating bore.
4. Install O-rings onto the water-cooled gate insert.

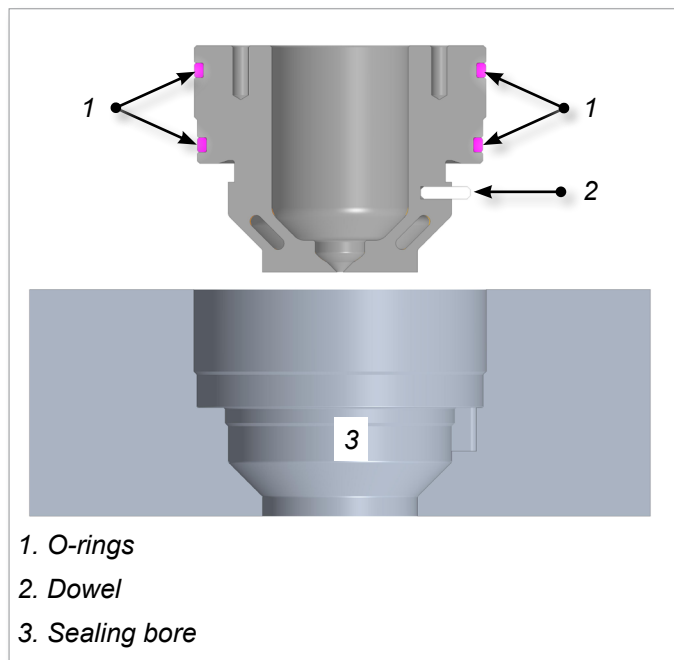


Figure 5-1 Water-cooled gate insert

5. Align the dowel to ensure proper orientation.

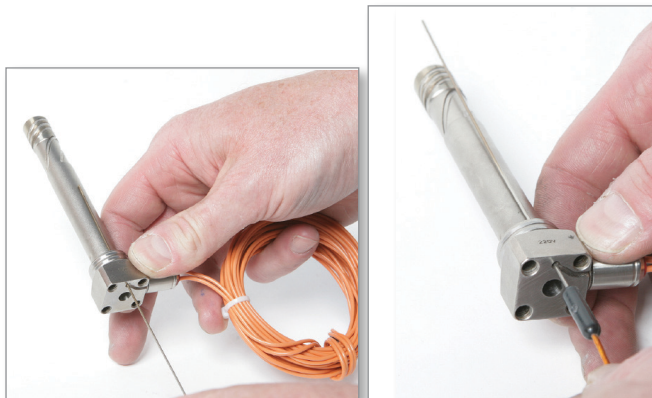
5.3 Installing a Thermocouple

5.3.1 Installing a Master Series-style Thermocouple

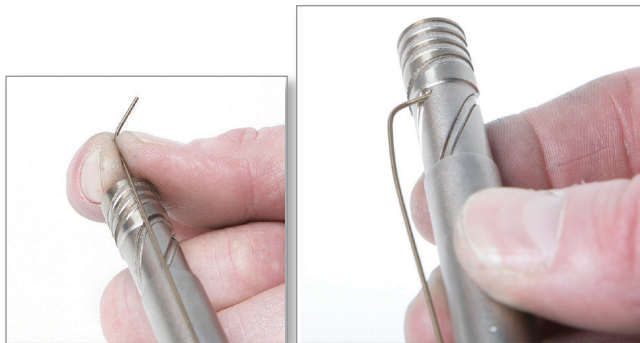
1. Clean the nozzle thermocouple bore.
 - For 1 mm (0.04 in.) thermocouples use a #58 drill in a pin vise.
 - For 1.5 mm (0.06 in.) thermocouples use a 1/16 inch drill in a pin vise.



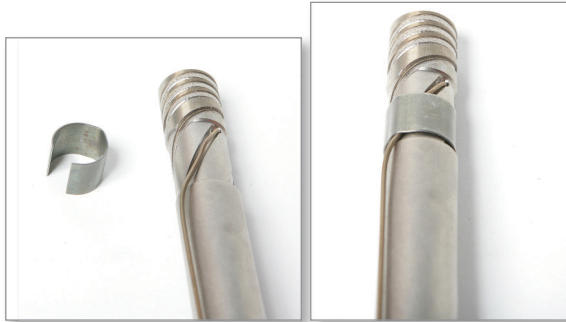
2. For front-mounted thermocouples, skip the following step.
3. Insert the thermocouple through the flange bore.



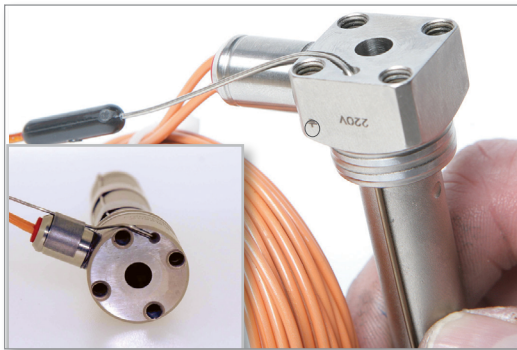
4. Manually bend the thermocouple tip against your thumb to approximately a 90° angle, ensuring bend length sufficient to reach the bottom of the thermocouple bore.



5. Dress thermocouple carefully alongside nozzle body and install retaining clip(s). Check parts list for recommended number of clips for the nozzle type. Check that the thermocouple fits into the recess of the clip. Make sure to use a retainer clip is at the top of the nozzle to keep the thermocouple inside the bore. This is especially important when thermocouples are assembled from the front.



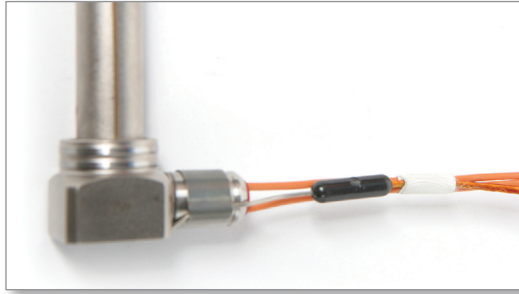
6. Install the terminal end retaining clip. Check that the thermocouple fits into the recess of the clip. Make sure that the terminal end of the thermocouple stays fully engaged in the slot.
7. Bend the thermocouple at the nozzle flange area.



8. Install the clip over the terminal end.



9. Use heat resistant tape to secure the nozzle wires and thermocouple wires just above or below the insulator pod.



5.3.2 Removing a Non-Front Mounted Thermocouple

**CAUTION**

Removing thermocouples will damage them. Removing thermocouples is not recommended unless you are replacing a damaged thermocouple.

1. Remove the thermocouple from the electrical box and wire channels.
2. Remove the nozzle from the manifold plate.
3. Remove the thermocouple retaining clips.
4. Remove the thermocouple.

5.4 Installing a Nozzle

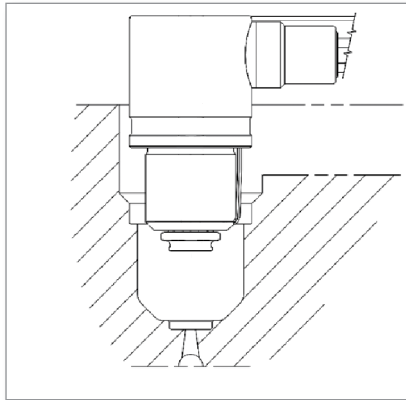
Systems with gate seals that are not accessible when fully assembled require the gate seals to be tightened hot prior to installation.

The mold plate needs to be in horizontal position when inserting nozzles. Care must be taken when handling the nozzles.

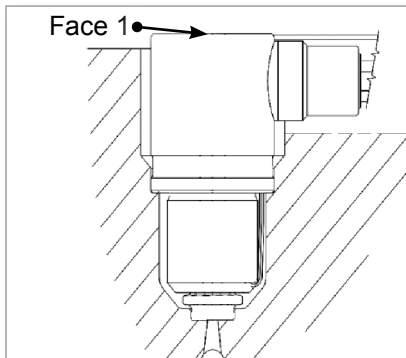
Special care must be taken with F-type, Hot Sprue and Hot Valve gating styles, where the transfer seal goes up into the part cavity. In these cases care is needed to prevent damage to the sharp edge of the gate seal and gate seal receiving bore.

Prior to commencing assembly verify manifold and nozzle cutouts in mold plates are to specification to ensure proper clearance to Hot Runner. Improper clearance will affect system performance.

1. Clean the nozzle well seating bore.
2. Install the nozzle.



3. Check that Face 1 is at the same level for all nozzles relative to the mold plate split line.



4. Check that nozzle sits squarely in nozzle well bore.

5.4.1 Master-Shield Centi, Deci, and Pico

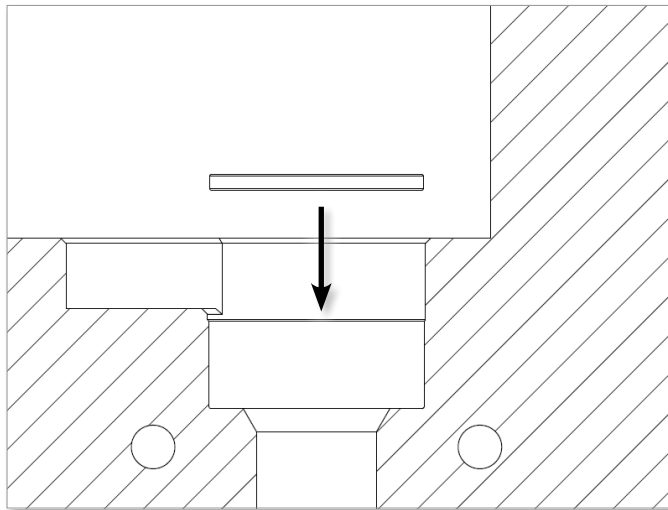
Refer to the following figure to identify the components.



Figure 5-2 Master-Series Pico nozzle with optional Master-Shield components

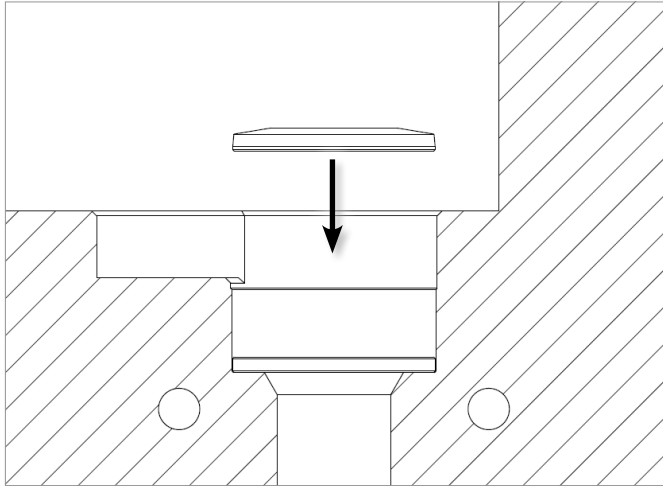
1. Hardened washer
2. Disc spring
3. Nozzle retainer
4. Nozzle

1. Clean the seating bore of the nozzle well.
2. Install the bottom hardened washer.

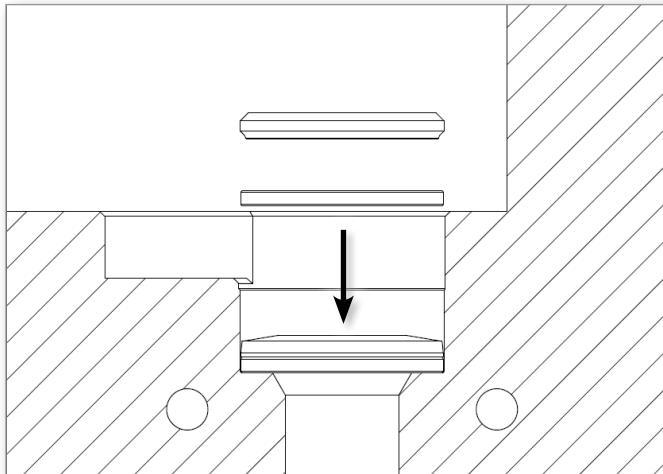


3. Apply high temperature grease to the spring.

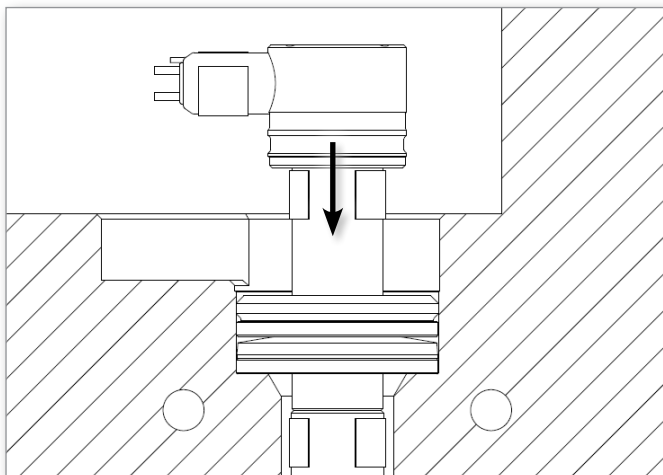
4. Install the disc spring in the correct orientation.



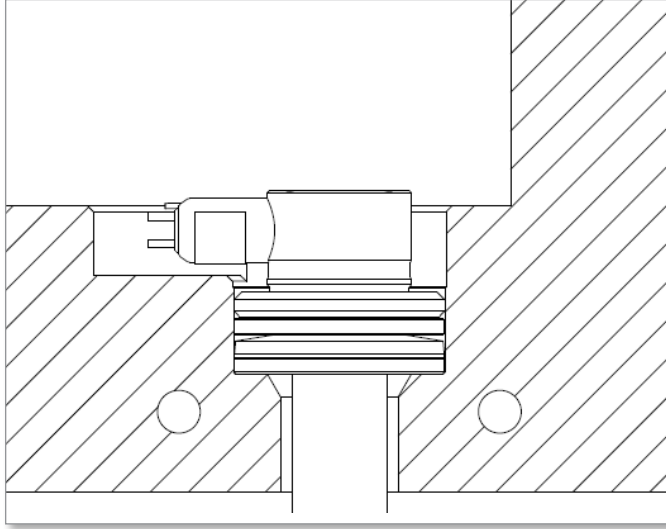
5. Install the top hardened washer.
Install the nozzle retainer.



6. Install the nozzle. For anti-rotation, use the bolts between the manifold and nozzle.



7. Make sure that the nozzle sits correctly in the nozzle well bore.



5.4.2 Master-Shield Femto

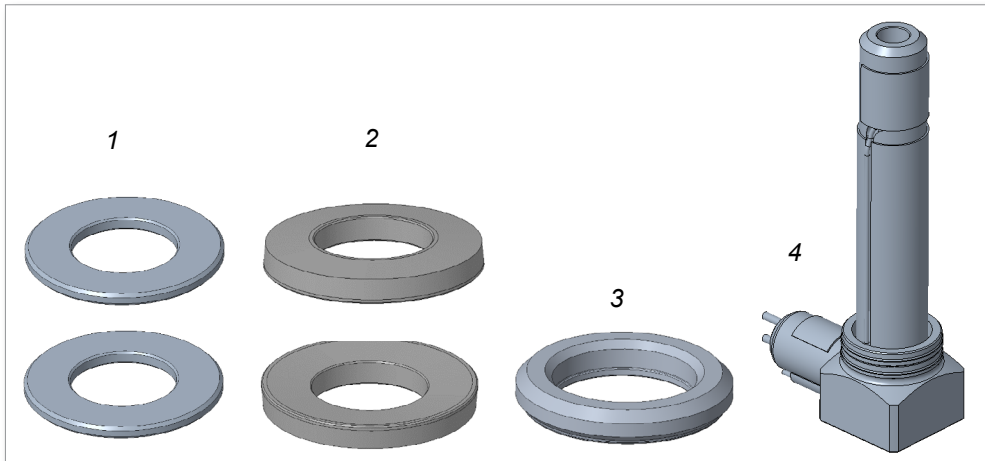
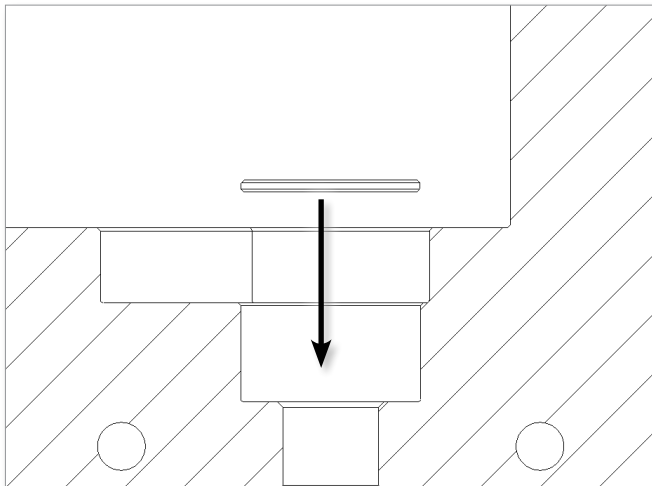


Figure 5-3 Master-Series Femto nozzle with optional Master-Shield components

- 1. Hardened washers
- 2. Disc springs
- 3. Nozzle retainer
- 4. Nozzle

- 1. Clean the seating bore of the nozzle well.
- 2. Install the bottom hardened washer.



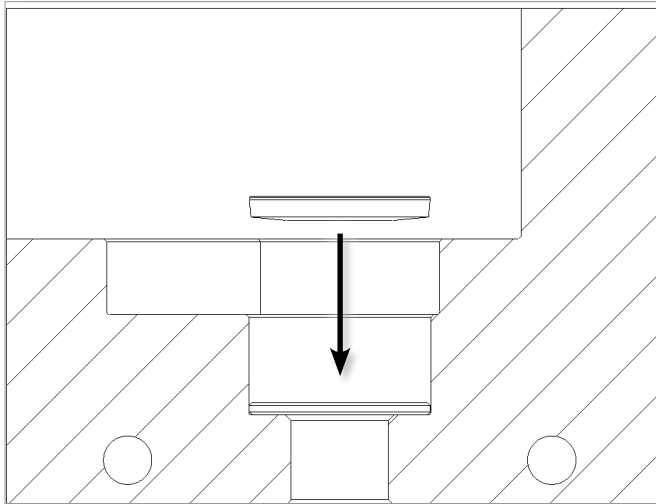
- 3. Apply high temperature grease to the first and second spring.

4. Install the bottom spring.



NOTE

The bottom spring has a different orientation from that of other Master-Shield systems.

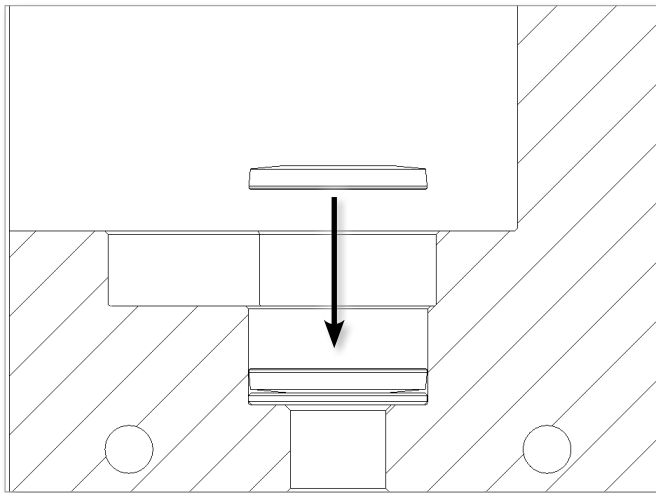


5. Install the top spring.

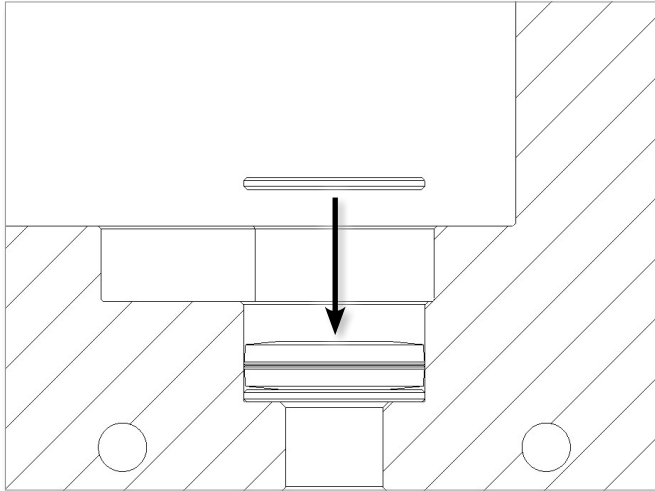


NOTE

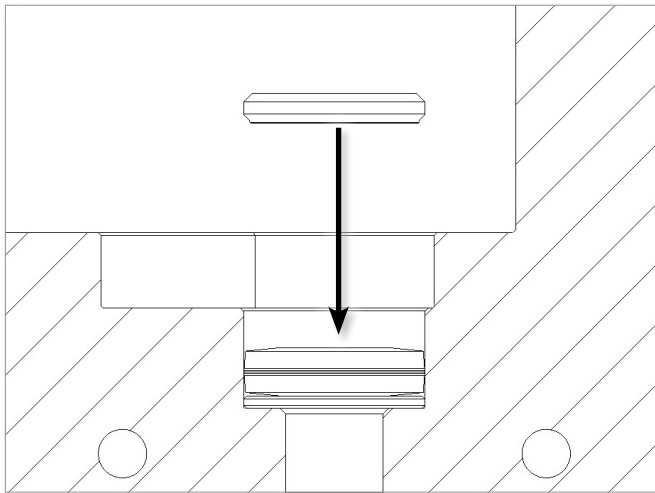
The top spring has a different orientation to that of the bottom spring.



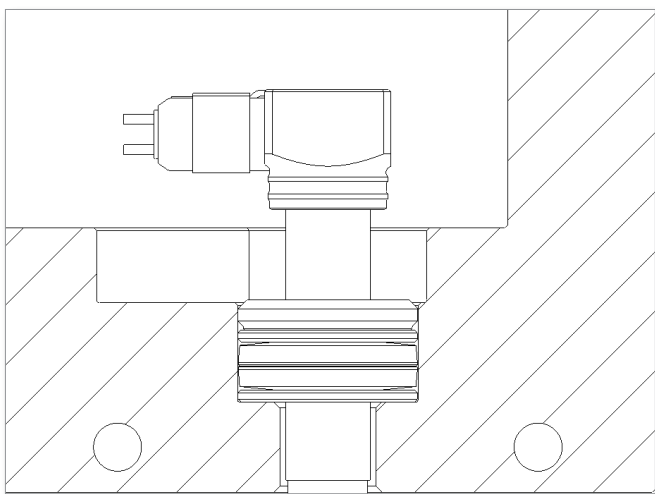
6. Install the top hardened washer.



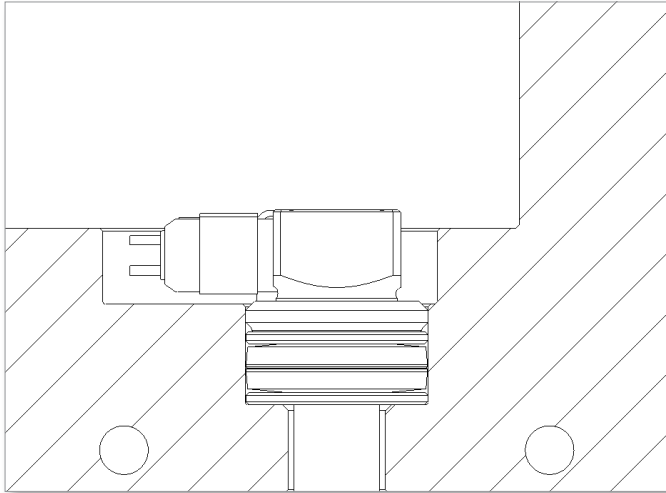
7. Install the nozzle retainer.



8. Install the nozzle. For the anti-rotation version, use the bolts between the manifold and the nozzle.



9. Make sure that the nozzle sits correctly in the nozzle well bore.



5.5 Installing a Nozzle Step

1. After the nozzle is installed, mount the step on top of the nozzle.
2. Apply anti-seize compound to the thread of each screw.
3. Lower the manifold into position on top of the step.
4. Install the screws through the manifold and the step into the nozzle.
5. Tighten screws to the value specified on the General assembly drawing.

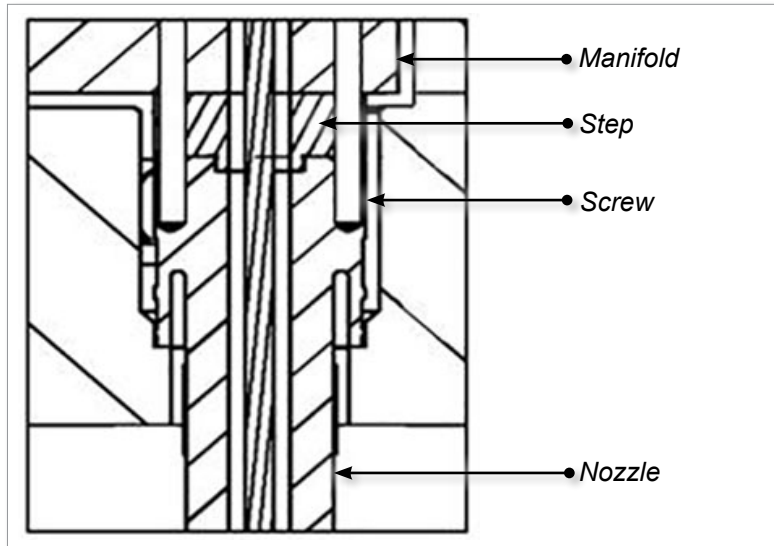


Figure 5-4 Step installation

5.6 Nozzle Wire Layout

5.6.1 Back Mounted Thermocouples

1. Place a zone number on each wire and thermocouple.
2. Try to organize and tape wires by zone and plug.
3. Install the wires into the wire channels and secure with wire retainers.
4. Feed the wires back through the wire channel in the mold base to the electrical box. Do not cut the wires until the remaining components are installed.

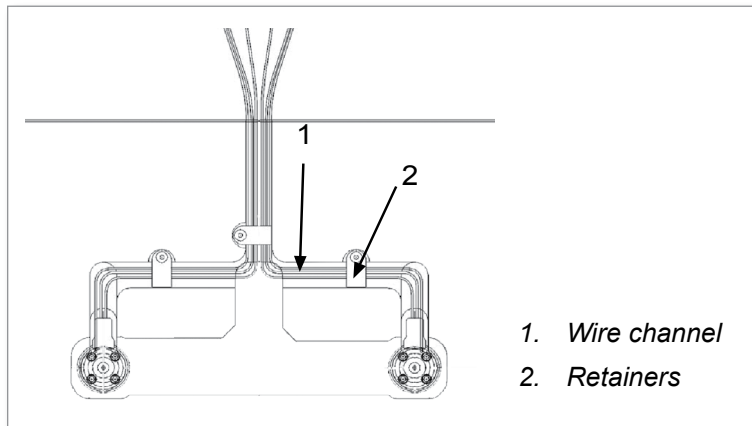


Figure 5-5 Wiring layout

5.6.2 Front Mounted Thermocouples

1. Place a zone number on each wire and thermocouple.
2. Try to organize and tape wires by zone and plug.
3. Install the wires into the wire channels and secure with wire retainers.
4. Feed the wires back through the wire channel in the mold base to the mold plug. Do not cut the wires too short. Leave sufficient wire for future maintenance and ease of access.

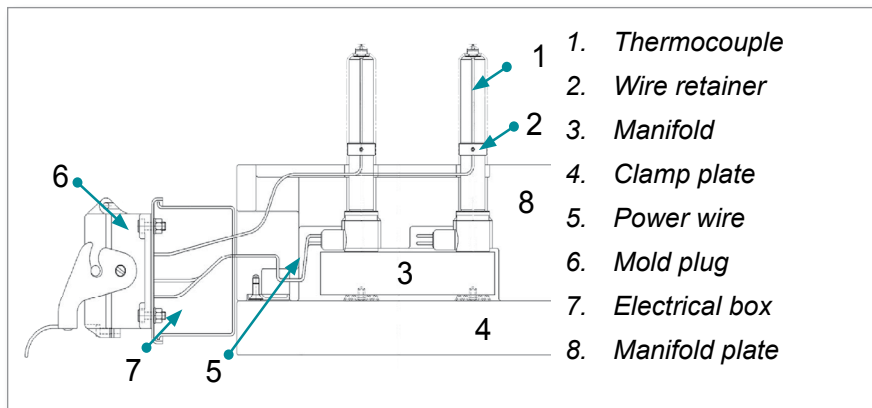


Figure 5-6 Thermocouple layout - side view

5.7 Installing a Valve Bushing

5.7.1 Types

Valve bushings can be either heated or unheated.

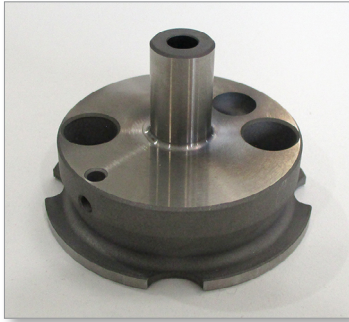


Figure 5-7 Unheated valve bushing



Figure 5-8 Heated valve bushing

5.7.2 Installing



WARNING - CRUSH HAZARD

Attach a crane of sufficient lifting capacity to the manifold if necessary. Make sure the lifting eyebolt, chain and crane can support the weight of the manifold. Failure to do so may cause serious injury or death.



WARNING- SHEARING HAZARD

Do not shorten the screw length. Failure to do so may cause serious injury or death.

This procedure applies to valve gated systems that are bolt-in design. Refer to the parts lists and your general assembly drawing to determine if your system has a valve bushing.

1. If the anti-rotation dowel pin is on the side of the valve bushing:
 - a) Install the dowel pin on the valve bushing.
 - b) Install the valve bushing on top of the nozzle.
2. If the anti-rotation dowel pin is on the top of the valve bushing:
 - a) Install the valve bushing.
 - b) Install the dowel pin.

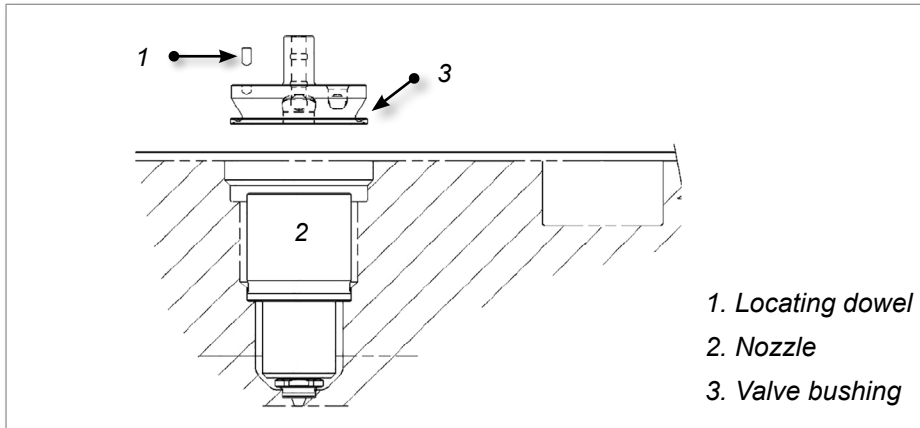


Figure 5-9 Valve bushing - dowel pin installation

3. Apply anti-seize compound to the threads of each screw.
4. Make sure that the dowels are in correct position.
5. Lower the manifold into position.
6. Install screws through the manifold and into the manifold plate (the mounting screw thread must start at the flange seal level). Refer to your general assembly drawings for correct screw size.
7. Tighten screws to value indicated on your general assembly drawings and secure manifold to the manifold plate.

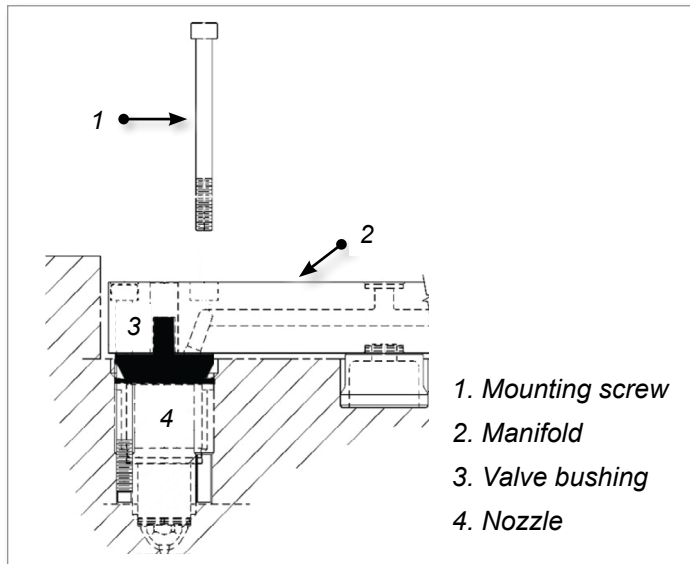


Figure 5-10 Valve bushing - screw installation

5.8 Installing a Manifold

Introduction

There are three methods used to locate the manifold:

1. Manifold locator with side anti-rotation dowel
2. Manifold locating dowel pin with side anti-rotation dowel
3. Manifold locator with bottom anti-rotation dowel

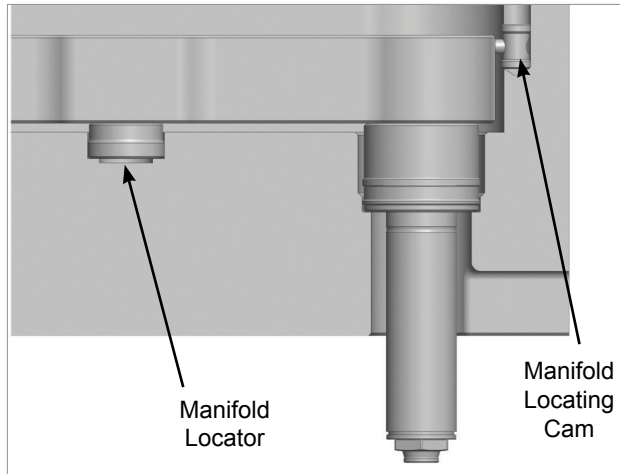


Figure 5-11 Manifold with a locator

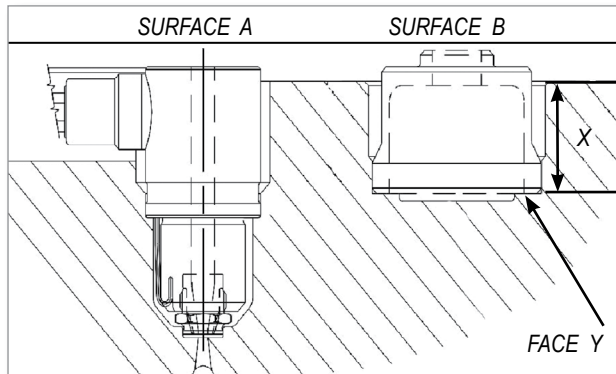


Figure 5-12 Locator surface

5.8.1 Manifold Locator



WARNING - CRUSH HAZARD

Make sure that the lifting eyebolt, chain and crane can support the weight of the manifold. Failure to do so may cause serious injury.

Depending on your system, the manifold locator may require final grinding. Refer to your general assembly drawing for details of your particular system.

Final Grinding Required

For some systems, manifold locators are supplied oversize (X) and must be ground to the same level as the top of the nozzles. In this case remove the material from the bottom face of the locator (FACE Y). This will allow SURFACE (A) and SURFACE (B) to be at the same level in the cold condition, or as specified on your general assembly drawing.

Final Grinding Not Required

In other systems the manifold locator does not require grinding and the height is determined by the cutout depth. In this case SURFACE (A) and SURFACE (B) will be at the same level in the hot condition.

1. Apply die spotting blue compound to the manifold locator into the bore to ensure proper seating.
2. Install the manifold locating cam onto its dowel pin.
3. If required, attach a crane of sufficient lifting capacity to the manifold.
4. Check for correct seating and height.
5. Check that there are no pinched wires.

5.8.2 Manifold Locating Dowel Pin

1. Install the dowel pin in the mold.
2. Check that the manifold locating dowel pin does not touch the top of the manifold.
3. Install the manifold locating cam onto its dowel pin.
4. Place the manifold on top of nozzles and locating dowel.

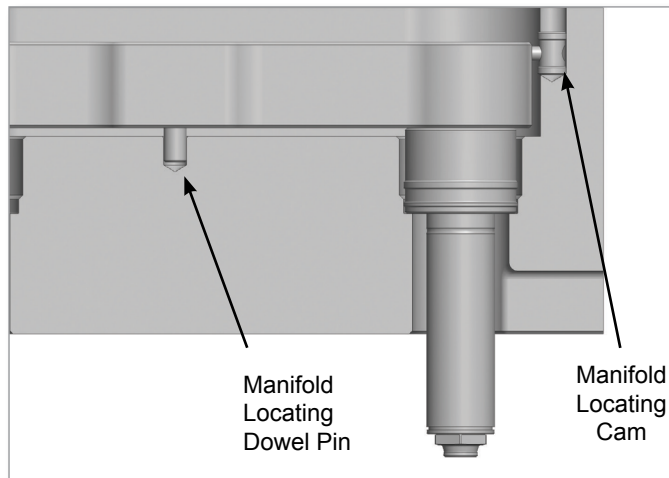


Figure 5-13 Manifold Locating with a dowel pin

5. Check for correct seating and height.
6. Check that there are no pinched wires.

5.8.3 Installing a Manifold Thermocouple

This procedure only applies to integrated systems.

1. Although not necessary, a thermal compound may be applied to the thermocouple tip to ensure a good contact.
2. Clean the thermocouple bore. Suggestion for 1.5 mm (0.06 in.) thermocouples is to use a 1/16 inch drill in a pin vise.
3. Insert the thermocouple into the bore. Check that the thermocouple is touching the bottom of the hole.
4. Press down on the thermocouple and gently bend the thermocouple sheath through 90°.
5. Check that the thermocouple sits in the manifold cutout.
6. Install the thermocouple washer and screw.
7. Install a zone number on each wire and thermocouple.
8. Tape wires for each zone together.
9. Install the wires into wire channels and secure with wire retainers.
10. Feed the wires back through the wire channel in the mold base to the electrical box.

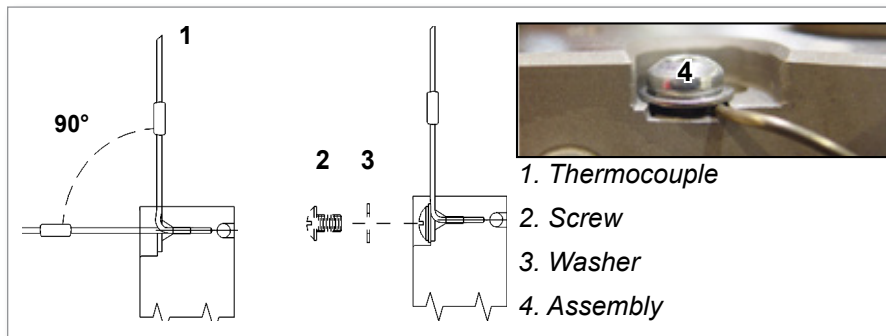


Figure 5-14 Thermocouple installation

5.9 Installing a Main Manifold

A main manifold distributes melt from the inlet component to one or more submanifolds. If you have a submanifold configuration, follow these instructions. This system will have one of two configurations for inlet seals.

Refer to your general assembly drawing to determine which applies.

- Inlet seal
- Manifold step

5.9.1 Installing an Inlet Seal

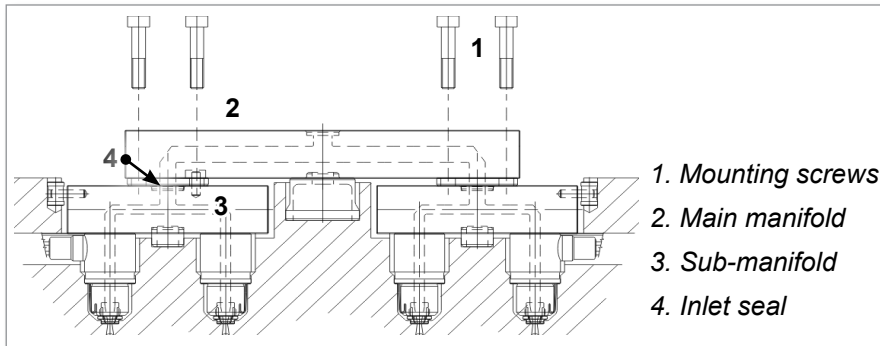


Figure 5-15 Install main manifold

Manifolds that use a seal without a step:

1. Place the inlet seal into all submanifold inlets.
2. Check that the inlet seal orientation is chamfer down.
3. Check that all inlet seal heights are at the same level.
4. Install the manifold locators. Refer to “Mounting the Manifold”.
5. Check that all components are free of debris.

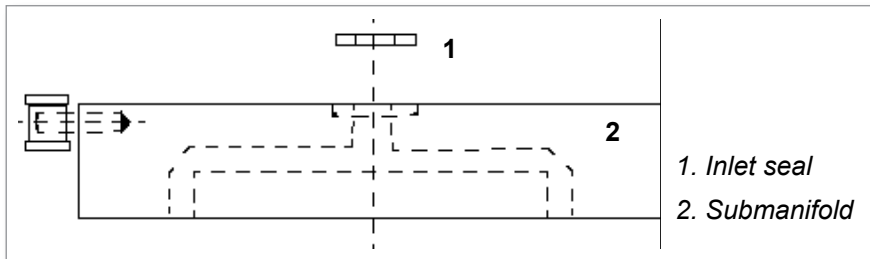


Figure 5-16 Inlet seal

5.9.2 Installing a Manifold Step

Manifolds that use inlet seals with a step:

1. Install the step inlet seal to the manifold.
2. Install the dowel pin into the seal and manifold.
3. Lower the main manifold into position.
4. Install manifold mounting screws and torque to required settings.
Refer to your general assembly drawing for specifications. On bridge manifold systems, mounting screws should be tightened to a torque 1/3 higher than that specified on your general assembly drawing
5. Install the manifold thermocouples. Refer to 5.8.3 Installing a Manifold Thermocouple.

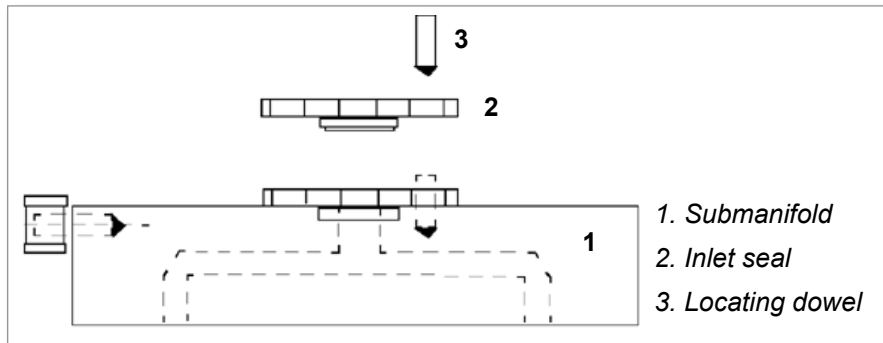


Figure 5-17 Manifold step

5.10 Installing a Pressure Disk or a Valve Disk in a Master-Series System

Review your parts list and general assembly drawing to determine the feature installed in your system.

- Pressure Disk - is compressed by thermal expansive forces to form part of the plastic sealing mechanism. This also helps to reduce thermal transfer to a minimum. These may or may not require grinding.
- Valve Disk - is compressed by thermal expansive forces to form part of the plastic sealing mechanism. Its high tolerance bore allows the valve pin to shift through it without plastic leaks and part of it enters the melt stream and helps guide the plastic flow without stagnation. These may or may not require grinding.

For additional information please refer to 4.6 Overview of System Types.

5.10.1 Pressure Disk: Final Grinding Required

This type of pressure disk is supplied oversize in height and requires grinding to dimensions specified on your general assembly drawing.

Pressure disk or valve disk height = Pocket depth - (Manifold thickness + nozzle flange + air gap)

Calculate Pressure Disk Height:

1. Calculate the following dimensions at ambient (room) temperature:
 - a) Measure the depth of the nozzle bore “a” from the top of the manifold plate to the nozzle support base.

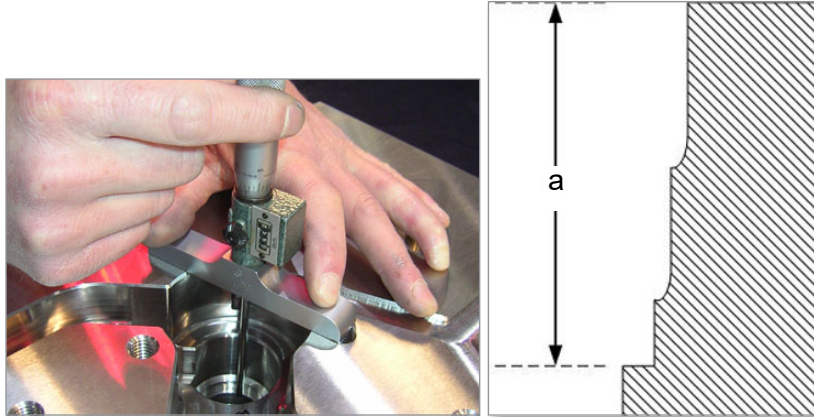


Figure 5-18 Calculating nozzle bore depth “a”

- b) Measure the top section of the nozzle flange “b”.

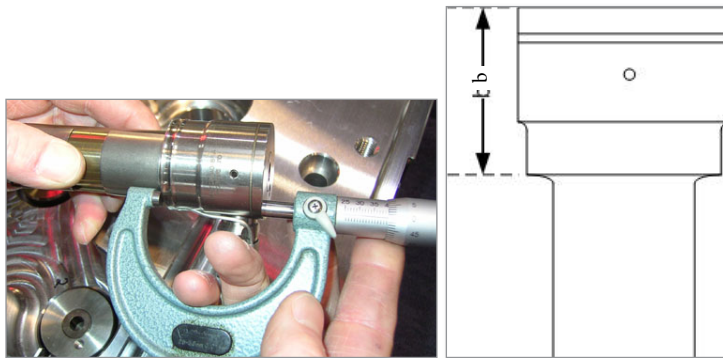


Figure 5-19 Calculating nozzle flange height “b”

- c) Measure the manifold thickness “c”.

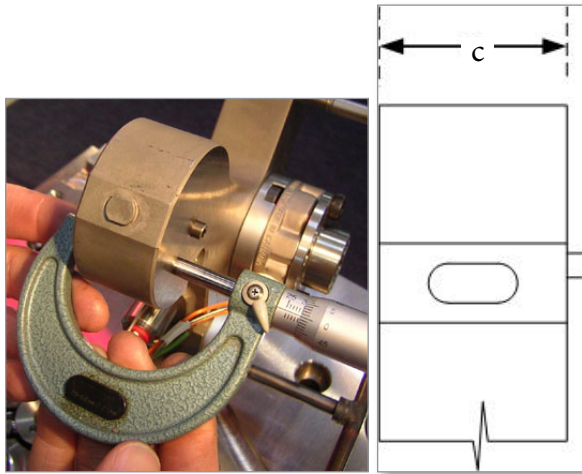


Figure 5-20 Calculating manifold thickness “c”

2. Calculate Pressure Disk height “d” = a – b – c – air gap.

This is the value (“d”) that is required for correct assembly. Refer to your general assembly drawing for reference values, such as the air gap.

3. The actual height (thickness) of the supplied pressure disk “e” will be of a value that is higher than the value “d”. Calculate the difference, and then divide by 2. This is the value that will need to be ground from each side of the pressure disk.

Example Calculations:

Nozzle pocket depth “a”: 91.39 mm (3.60 in.)

Nozzle flange height “b”: 43.16 mm (1.70 in.)

Manifold thickness “c”: 43.16 mm (1.70 in.)

Air gap as noted on drawing: 0.05 mm (0.002 in.)

Pressure disk height “d”: $91.39 - 43.16 - 43.16 - 0.05 = 5.02$ mm (0.20 in.)

Supplied pressure disk “e”: 5.10 mm (0.20 in.)

Difference between supplied pressure disk “e” and required pressure disk “d”: 5.10 mm - 5.02 mm = 0.08 mm (0.003 in.)

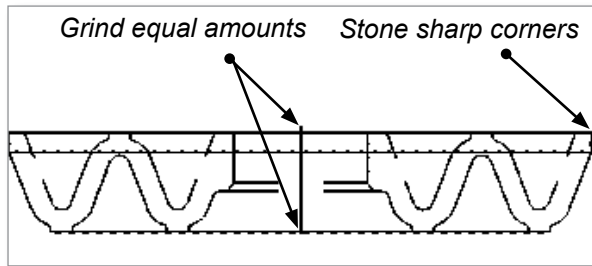
Material to be removed from each side of the pressure disk:

0.08 mm \div 2 = 0.04 mm (0.002 in.)

Nozzle bores and pressure disks must be within tolerances specified in your general assembly drawing.

5.10.2 Installing a Pressure Disk

1. Install the manifold to the nozzle.
2. Refer to your general assembly drawing for pressure disk dimensions before calculating the pressure valve disk height.
3. Grind equal amounts from each side of the pressure disk to give 0 to 0.025 mm (0.001 in.) cold clearance and retain maximum strength of the 'V' form. Some systems require a larger air gap, refer to your general assembly drawing.
4. Remove the sharp corners after grinding and clean the disk well to ensure no grinding dust remains on the disk.
5. Install the pressure disk spring dowel to the manifold.
6. Install the pressure disk to the manifold.



5.10.3 Pressure Disk: Final Grinding Not Required

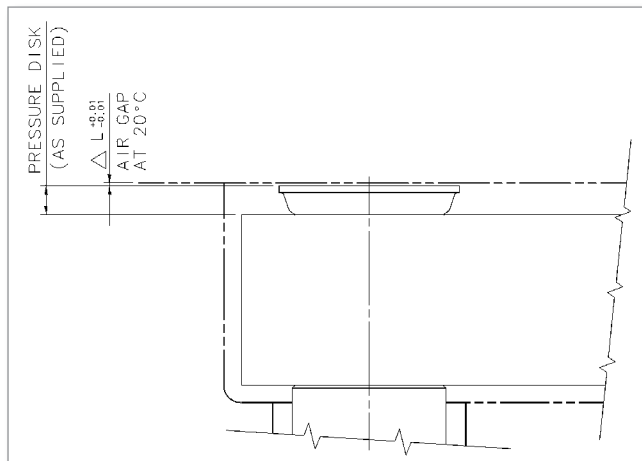


Figure 5-21 Optional pressure disk mounting detail

Alternate Method - Air gap adjustment from top clamp or hydraulic plate.

1. Calculate and machine the nozzle bore seat with additional air gap value. (Example: Flange height + Manifold height + Pressure disk height + Air gap value)
2. Install the nozzle into the manifold plate.
3. Install the manifold to the nozzle.
4. Refer to your general assembly drawing for pressure disk locations.
5. Measure the gap between the top of the manifold plate and the top of the pressure disk. Ensure that it matches the air gap value on your general assembly drawing.

5.10.4 Installing a Valve Disk

These valve disks are supplied with stock allowance (oversized in height), and they require grinding to the final dimension specified on the system general assembly drawing.

1. Grind the valve disk on top side only.
2. Remove sharp corners after grinding and clean the valve disk, especially inside the valve pin bore.

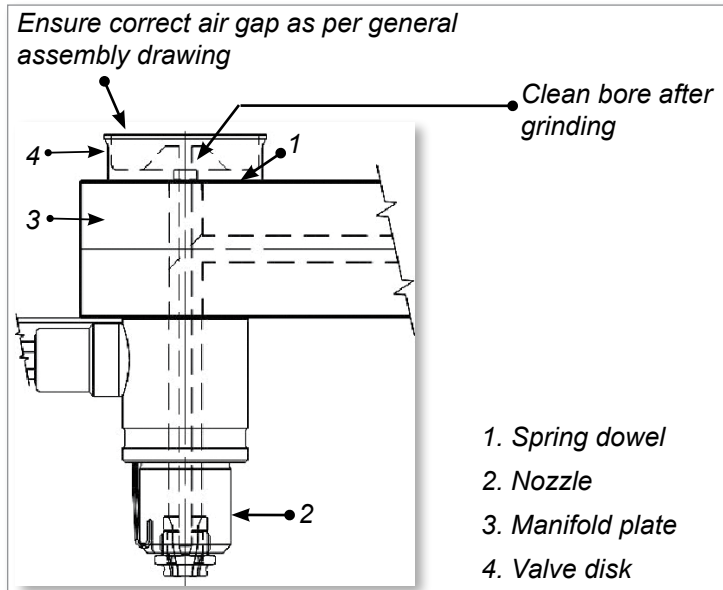


Figure 5-22 Manifold to nozzle mounting

3. Install the manifold to the nozzle.
4. For 1-piece valve disk - Install the valve disk in appropriate orientation.
For 2-piece valve disk - Insert valve stem into the manifold in appropriate orientation. Slide valve disk flange over the stem. See Figure 5-23.

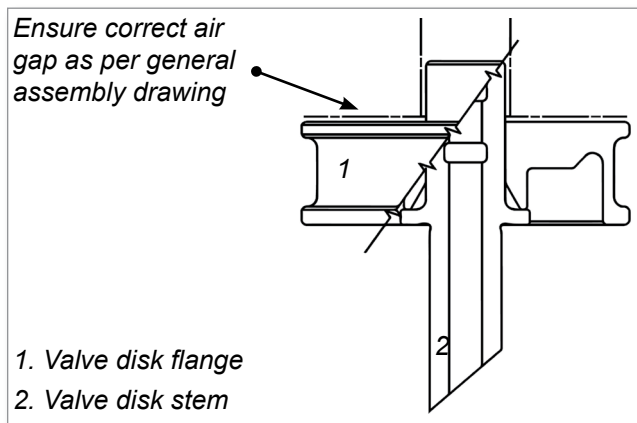


Figure 5-23 2-piece valve disk

5. Ensure correct air gap between the valve disk and the top plate as specified in your general assembly drawing.
6. For information on removal, refer to 10.2 Valve Disks on page 10-3.

Alternate Method - Air gap adjustment from top clamp or hydraulic plate

1. Calculate and machine the nozzle bore seat with additional air gap value.

Example:

Flange height + Manifold height + Valve disk height + Air gap value

2. Install the nozzle into the manifold plate.
3. Install the manifold to the nozzle.
4. Refer to your general assembly drawing for valve disk locations.
5. Measure the gap between the top of the manifold plate and the top of the valve disk. Ensure that it matches the air gap value on your general assembly drawing.

5.11 Installing a Support Bushing or a Valve Disk in a Master-Shield System

5.11.1 Installing a Support Bushing



WARNING

Make sure that the lifting eyebolt, chain and crane can support the weight of the manifold. Failure to do so may cause serious injury.

For systems with Master-Shield, support bushings are used for non-valved systems. See Figure 5-24.

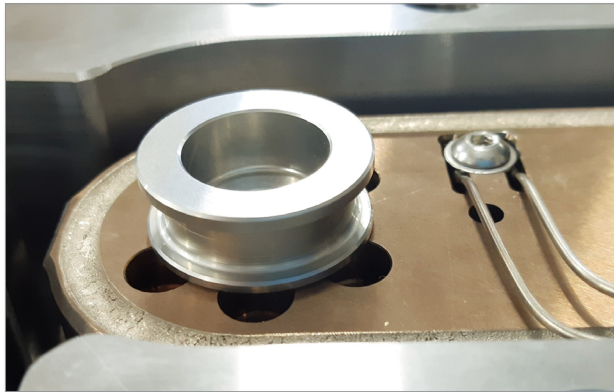


Figure 5-24 Support bushing for systems with Master-Shield

Support bushings are supplied to final dimensions. No final grinding is required. Refer to your general assembly drawing for more information.

1. Install the manifold into the plate and ensure that it sits on the nozzles.
2. Use your general assembly drawings to locate the positions for the support bushings.

- Use a dowel pin to install all of the support bushings into the manifold. See Figure 5-25.

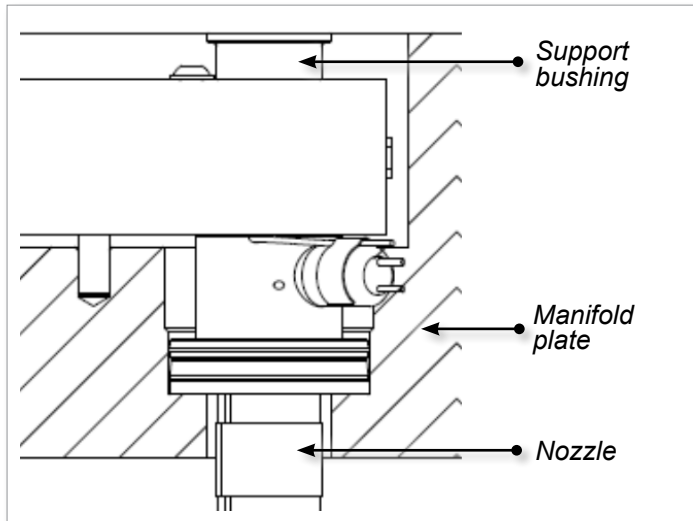


Figure 5-25 Support bushing in Master-Shield systems

5.11.2 Installing a Valve Disk



WARNING - CRUSH HAZARD
 Make sure the lifting eyebolt, chain and crane can support the weight of the manifold. Failure to do so may cause serious injury.

Valve disks are supplied to final dimensions. No final grinding is required.

Some systems with Master-Shield require the use of screws as part of the installation process. Please refer to your general assembly drawing to determine if your system requires screws.

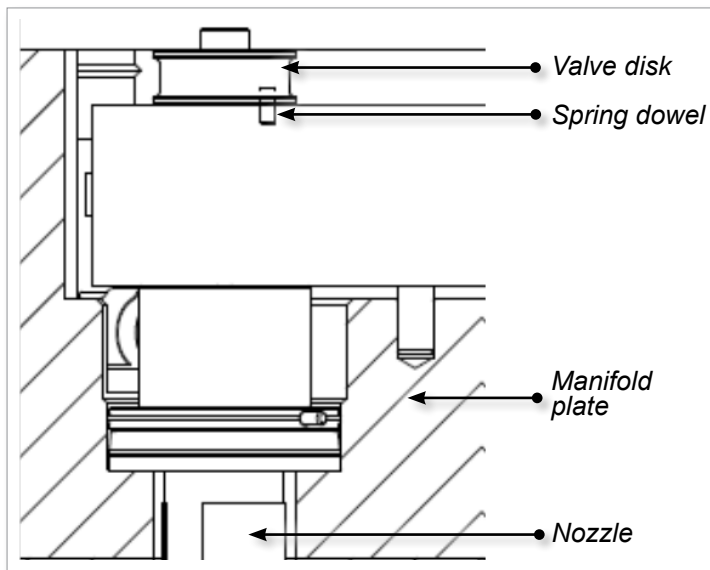


Figure 5-26 Master-Shield system with a valve disk

- Install the manifold into the plate and ensure that it sits on the nozzles.
- Refer to your general assembly drawing to determine the type of valve disk for your system before doing the following step.

3. Install the valve disk.
 - a) For 1-piece valve disk - Install the valve disk in appropriate orientation.
 - b) For 2-piece valve disk - Insert valve stem into the manifold in appropriate orientation. Slide valve disk flange over the stem.

5.12 Installing a Heater Plate



CAUTION

Do not control the heater plate from a thermocouple in the manifold. Heater plates are controlled by a thermocouple located in the heater plate.

Make sure that you do not pinch or damage the thermocouple.

Do not overtighten the mounting screws. This could result in the heater plate losing contact with the manifold plate. Refer to your general assembly drawing for the correct torques.

Bronze heater plates are directly interchangeable with previous copper or aluminum based plates that may exist on your Mold-Masters system. However, when multiple heater plates are controlled by one thermocouple, these heater plates must be made of the same material, be of equal wattage and be located in similar thermal environments.

The following procedure applies to systems with external heater plates. Refer to your general assembly drawing to determine which heater plate applies to your system.

1. Clean the thermocouple bore. Suggestion for 1.5 mm (0.06 in.) thermocouples is to use a 1/16 inch drill in a pin vise.
2. Insert the thermocouple into the bore. Ensure the thermocouple is touching the bottom of the bore hole.

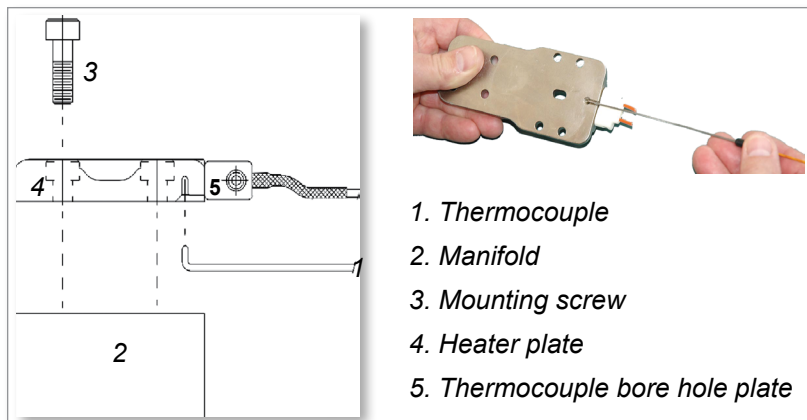


Figure 5-27 Thermocouple installation

3. Press down on the thermocouple and gently bend to 90°.
4. Secure the heater plate to the manifold. Refer to your general assembly drawing for location. Use anti-seize compound on the threads.

**NOTE**

Heater plates mounted on the side of the manifold may require heater plate holders. See the following figure if applicable.

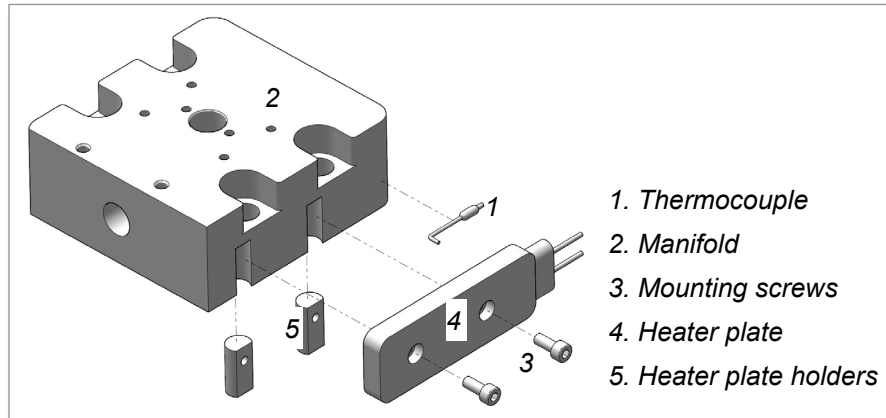


Figure 5-28 Thermocouple installation - assembly

**NOTE**

Heater plate wires should be isolated and grouped so that they do not have to be disconnected if the manifold needs to be dismantled for repair.

5. The heater plates are supplied with the power wires connected. Place a zone number on each wire and thermocouple.
6. Tape wires for each zone together.
7. Install the wires into wire channels and secure with wire retainers.
8. Feed the wires back through the wire channel in the mold base to the electrical box.

5.13 Installing Inlet Components



CAUTION

For all inlet components it is important that the mold locating ring is touching the inlet component just enough to seal the area. This should be double checked with the system drawings.

The following procedures refer to different system configurations. Refer to your parts list and general assembly drawings to determine your system type.

5.13.1 Unheated Back Plate

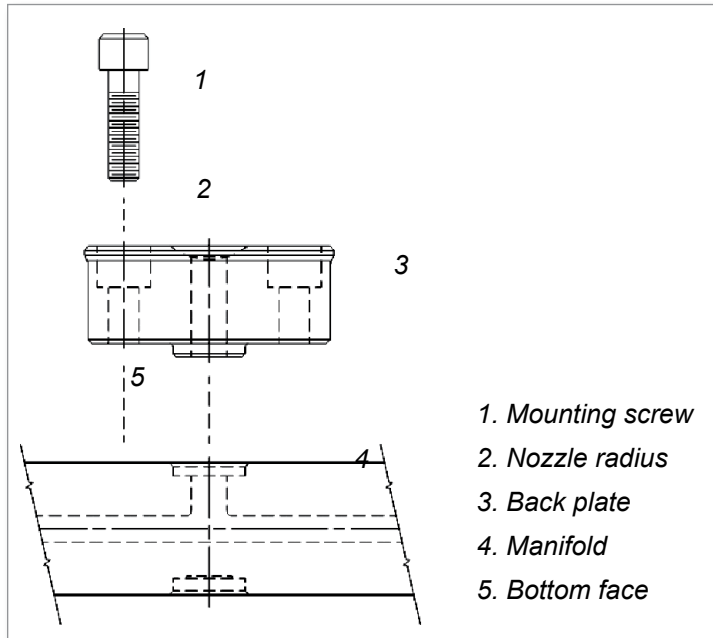


Figure 5-29 Back plate installation

1. Check the machine nozzle radius.
2. Check the seating on the bottom face of the back plate and manifold.
3. Install the back plate onto the manifold.
4. Install M8 mounting screws through the back plate to the manifold using anti-seize compound on threads.
5. Tighten screws to value indicated on your general assembly drawing in a cross pattern, in 7 Nm (5 lbf-ft) increments.



CAUTION

The machine nozzle bore should be no less than 1.0 mm (0.040 in.) smaller than the back plate bore and no larger than the back plate bore. Failure to follow this guideline may damage parts.

5.13.2 Heated Back Plate

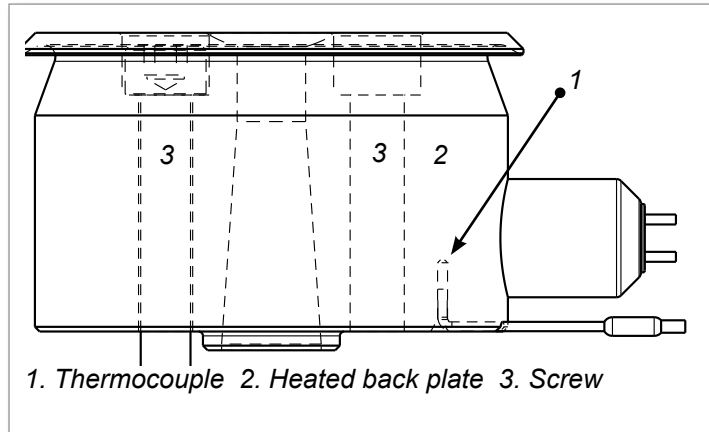


Figure 5-30 Heated back-plate assembly

The heated back plate may require the machine nozzle radius to be added.

1. Place the heated back plate on the manifold.
2. Rotate the heated back plate to align with the tapped holes in the manifold and align terminals with cut out.
3. Install mounting screws through the heated back plate into the tapped holes of the manifold. Use anti-seize compound on the screws.
4. Tighten screws to values indicated on your general assembly drawing.
5. Place zone number on each wire and thermocouple.
6. Tape wires for each zone together.
7. Install the wires into the wire channels and secure with wire retainers.
8. Feed wires back through the wire channel in the mold base to the electrical box.

5.13.3 Center Heater (Direct mount)

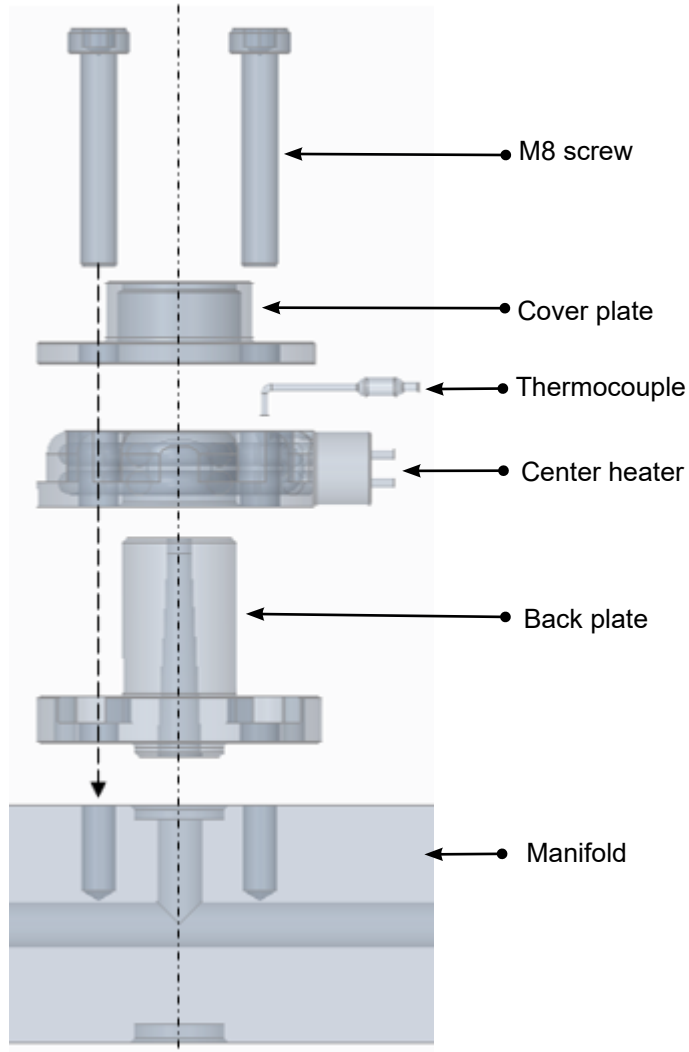


Figure 5-31 Direct-mount center-heater assembly

1. Install the back plate on the manifold.
2. Mount the center heater on the back plate.
3. Optional: Apply a thermal compound to the tip of the thermocouple to ensure good contact.
4. Install the thermocouple.
5. Install the cover plate.
6. Apply anti-seize compound to the M8 mounting screws.
7. Install the M8 mounting screws through the cover plate into the tapped holes of the manifold.
8. Tighten the screws to the torque values in your general assembly drawings.

5.13.4 Center Heater (Indirect mount)

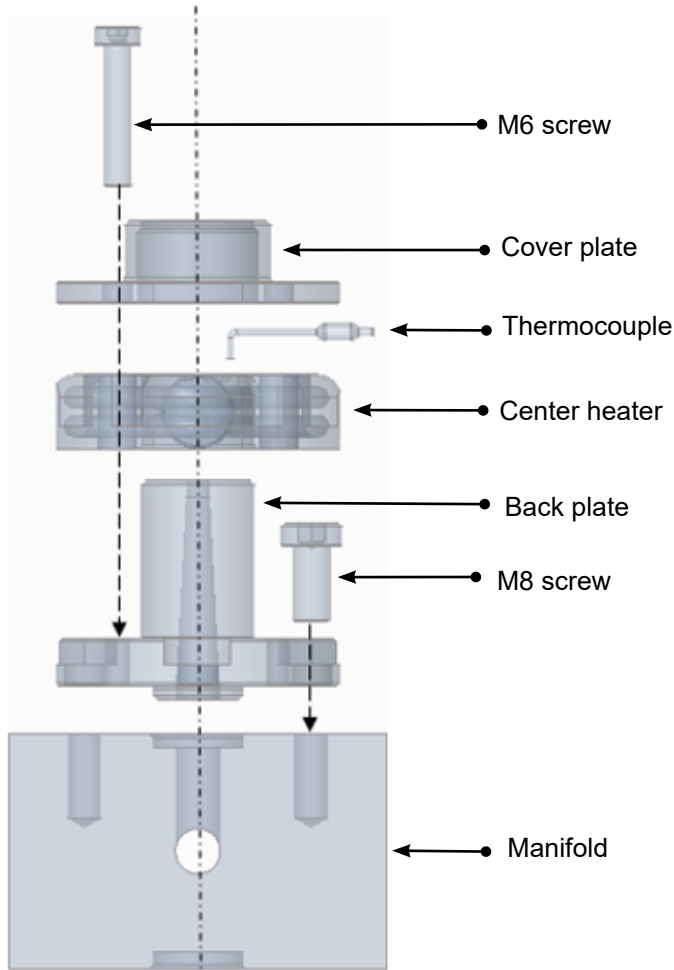


Figure 5-32 Indirect-mount center-heater assembly

1. Install the back plate on the manifold.
2. Apply anti-seize compound to the M8 mounting screws.
3. Install the M8 mounting screws through the cover plate into the tapped holes of the manifold.
4. Mount the center heater on the back plate.
5. Optional: Apply a thermal compound to the tip of the thermocouple to ensure good contact.
6. Install the thermocouple.
7. Install the cover plate.
8. Apply anti-seize compound to the M6 mounting screws.
9. Install the M6 mounting screws through the cover plate into the tapped holes of the backplate.
10. Tighten the screws to the torque values in your general assembly drawings.

5.13.5 Inlet Extension

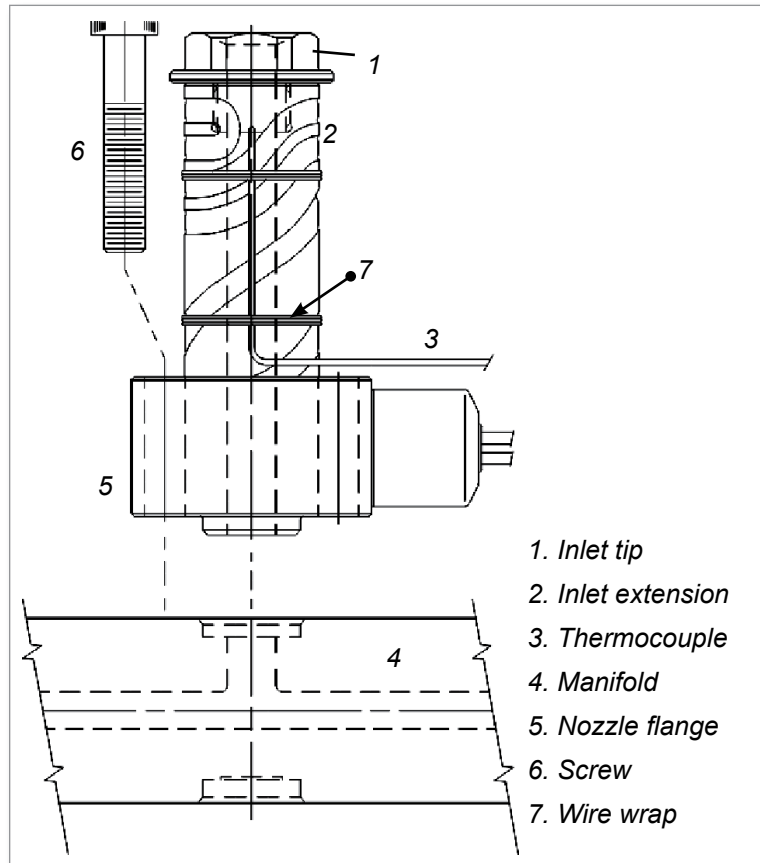


Figure 5-33 Inlet extension

1. Place the inlet extension on the manifold.
2. Install mounting screws through the nozzle flange and into the manifold.
3. Tighten screws to manifold using anti-seize compound on threads.
4. Place a zone number on each wire and thermocouple.
5. Tape wires for each zone together.
6. Install the wires into the wire channels and secure with wire retainers. Feed the wires back through the wire channel in the mold base to the electrical box.

5.13.6 Inlet Extension with Pressure Sleeves



CAUTION
Always install the inlet extension, pressure sleeve, clamp plate and locating ring with the mold plates in the horizontal position. Failure to do so could cause damage to the components and leaks.

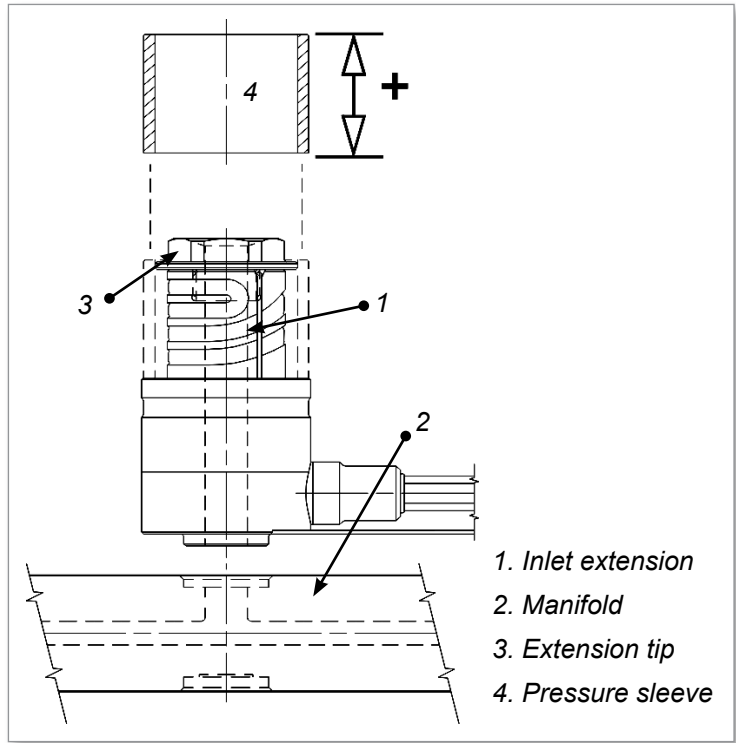


Figure 5-34 Inlet extension with sleeve

1. Place the inlet extension on the manifold.
2. Cut the inlet extension pressure sleeve to the required height.



NOTE
A pressure sleeve is supplied oversized in length. Refer to your general assembly drawing to determine the proper length of the pressure sleeve.

3. Chamfer the outside edge of the pressure sleeve.
4. Place zone number on each wire and thermocouple.
5. Tape wires for each zone together.
6. Install the wires into the wire channels and secure with wire retainers.
7. Feed the wires back through the wire channel in the mold base to the electrical box.
8. For electrical checks, refer to Section 7 - Electrical Testing.

5.14 Hydraulic and Pneumatic Actuators



WARNING - READ MANUAL

Read Section 3 - Safety on page 3-1 before assembling or installing valve actuators.

This section explains how to assemble and install the valve actuator for:

- 5500 Series
- 6500, 6600, and 6700 Series
- 7100 Series
- 8400, 8500, 8600 AR, 8700 and 8800 Series

5.14.1 Valve Actuator Assembly

The following procedures require certain parts to be lubricated.

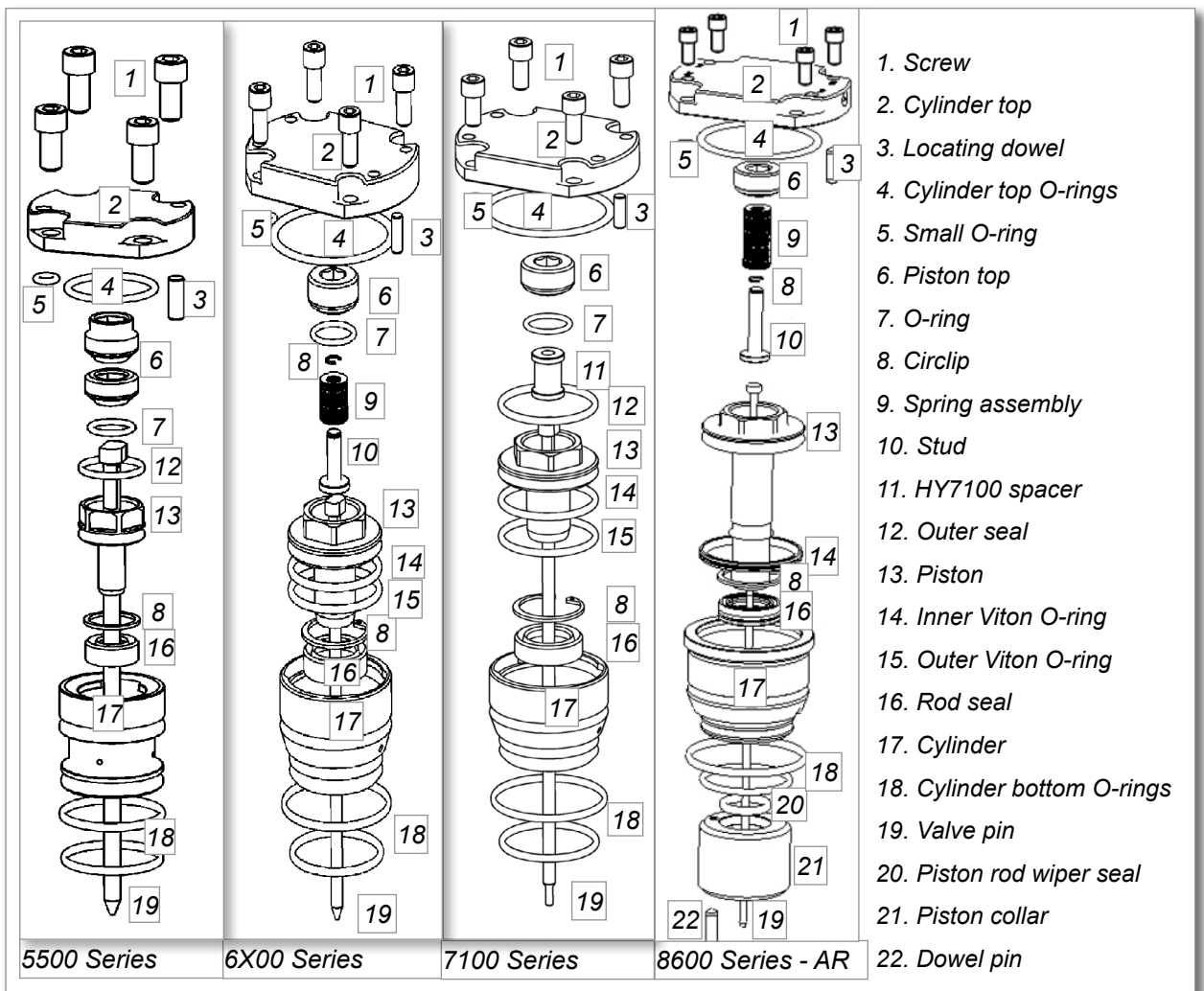


Figure 5-35 Valve actuator components

5.14.2 Pre-Installation

1. Prior to installing the actuator unit, check that all fluid lines in the mold plate are deburred and clean.
2. Use denatured alcohol to remove the rust inhibitor compound from each part. Do not clean the interior of the cylinder.

5.14.3 Recommendations for Valve-Gate Air Circuits

The following are recommendations to get the best possible performance from a pneumatically actuated valve-gated Hot Runner.

- No more than 32 cavities/nozzles per air circuit
- Air supply should be clear and dry at a pressure between 550–830 kPa (80–120 psi). Insufficient air pressure provided to the Hot Runner can lead to valve pins seizing, sticking, and/or posting on the molded part.
- A four-way air solenoid should be on the machine for every air circuit in the hot runner. For example, if the hot runner has four separate air circuits, the machine should have four separate air solenoids controlling the four air circuits.
- For air circuits with less than 24 cavities/nozzles, the air solenoids must have a minimum flow coefficient (C_v) value of 1.5. If the air circuit has 24 or more nozzles, the machine solenoid must have a minimum C_v value of 3.0.
- The air flow rate coming out of each machine solenoid should be a minimum of 0.018 cubic meters per minute (0.625 standard cubic feet per minute (scfm)) per drop. This should be measured with air flowing through all of the solenoids on the machine at the same time.
- Air hoses running from the machine solenoids to the Hot Runner should have an internal diameter no less than 12.7 mm (1/2")
- Air hoses should be as short as possible and should all be the same length from the solenoid to the Hot Runner

5.14.4 Assembling a Cylinder Bottom

1. Insert the rod seal support disk into the cylinder (6X00 Series and 7100 Series only).
2. Press the rod seal into position.
3. Install the circlip with sharp edges facing up.
4. Lubricate the bottom cylinder external O-rings and install.

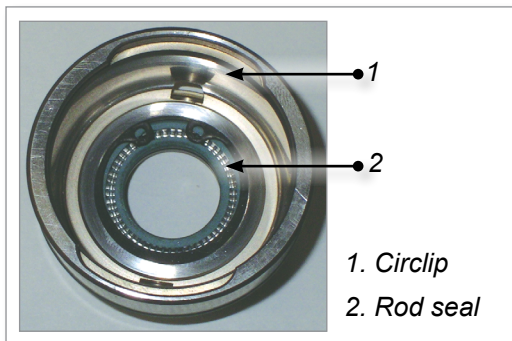


Figure 5-36 6X00 Series and 7100 Series bottom cylinder



Figure 5-37 6X00 Series and 7100 Series bottom cylinder O-rings

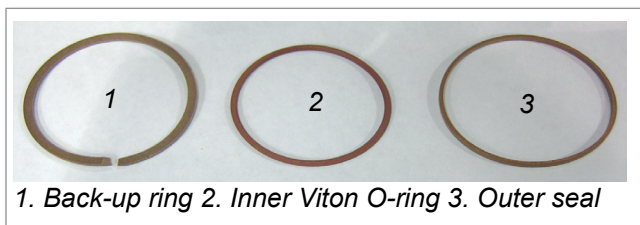


Figure 5-38 Seal kit PS0003

5.14.5 Piston Assembly

5.14.5.1 5500 Series

Lightly use silicone grease and install the O-ring on the piston.

5.14.5.2 6X00 and 7100 Series

1. Using silicone grease, lightly grease and install the inner Viton O-ring on the piston.
2. Install the back-up ring.
3. Install the outer seal. The seal should sit on top of the inner Viton O-ring. An installation tool is available (PS0003TOOL02) for installing the seal.
4. Once all 3 rings have been assembled, place installation tool PS0003TOOL01 over assembly as shown and allow rings to settle.

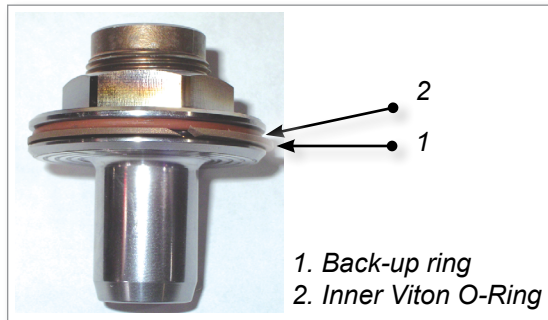


Figure 5-39 Piston assembly

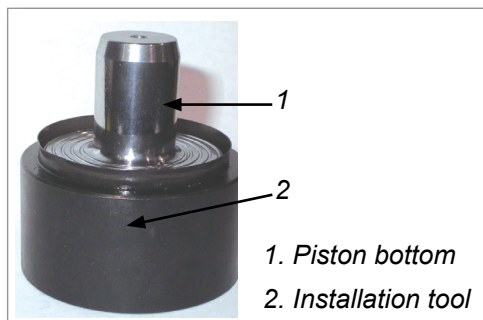


Figure 5-40 Piston bottom with installation tool

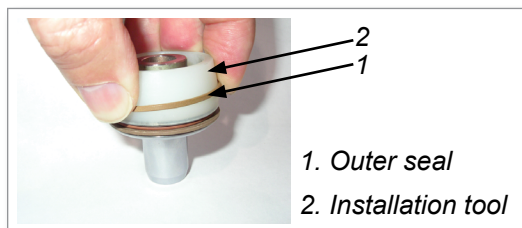


Figure 5-41 Outer seal assembly

5.14.6 Assembling a Cylinder Top

On the inside face of the cylinder top:

1. Insert the locating dowel.
2. Using silicone grease, lightly grease and insert the small O-ring.
3. Using silicone grease, lightly grease and insert the large O-ring.

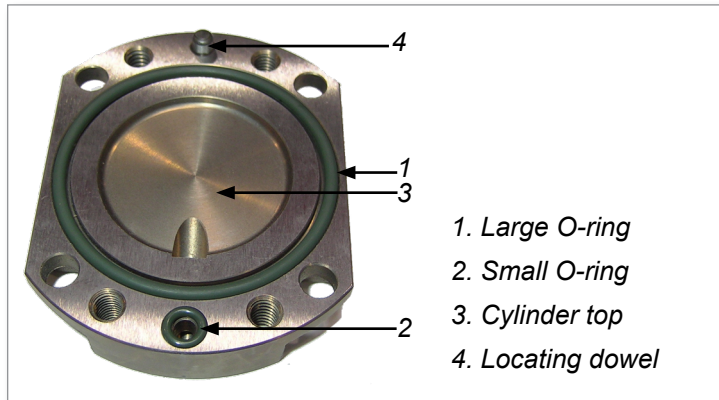


Figure 5-42 Typical cylinder top

5.14.7 Finishing the Tip of a Valve Pin

5.14.7.1 5500 Series

1. Install the cylinder (where applicable) and piston bottom (without the pin and piston top) into the hydraulic plate.
2. Measure the distance AD and AC.

IMPORTANT

The heat expansion difference must be removed from the pin head.

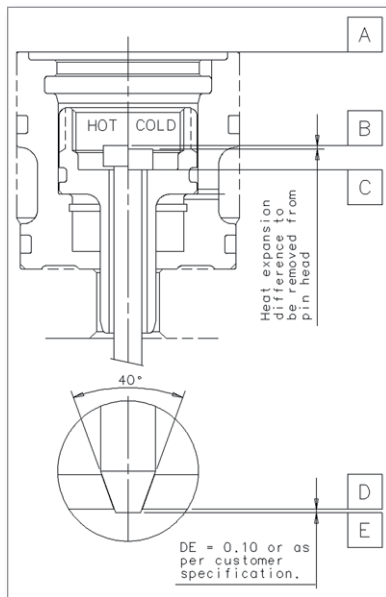


Figure 5-43 5500 Series - Measure distance

3. Cut the pin to the length detailed in your general assembly drawing for your job.

4. Grind the valve pin tip at the angle detailed in your general assembly drawing for your job.
5. Lap the tip of the pin into the land area (steel section in the gate area) using a lapping guide bushing or valve bushing as a lapping guide. We recommend 400 - 600 grit lapping paste.

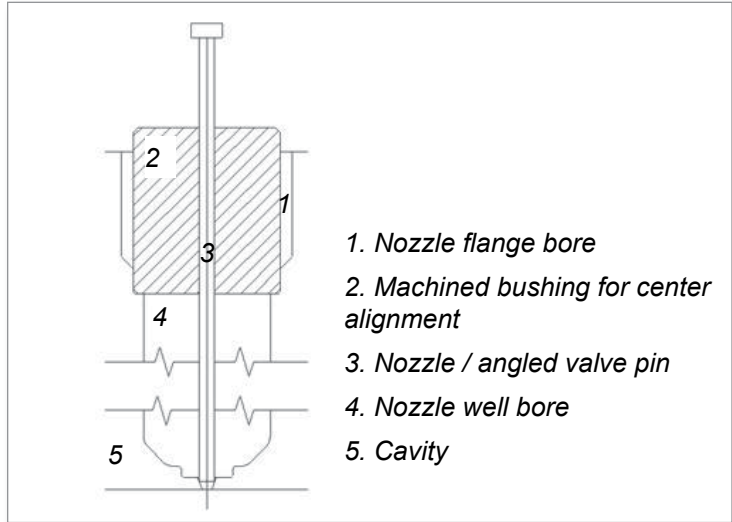


Figure 5-44 Bushing for pin tip

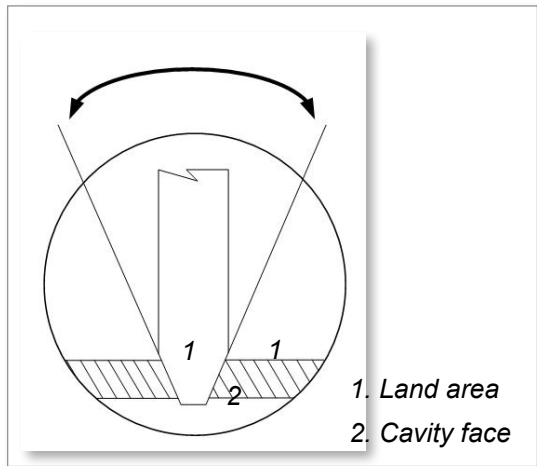


Figure 5-45 Land location

5.14.7.2 6X00 Series

1. Cut the pin to the length detailed in your general assembly drawing for your job..
2. Grind the valve pin tip to the correct angle.
Refer to your general assembly drawing or Gate Detail drawing for grinding specifications.
3. Lap the tip of the pin into the land area (steel section in the gate area) using a lapping guide bushing or valve bushing as a lapping guide. We recommend 400 - 600 grit lapping paste.

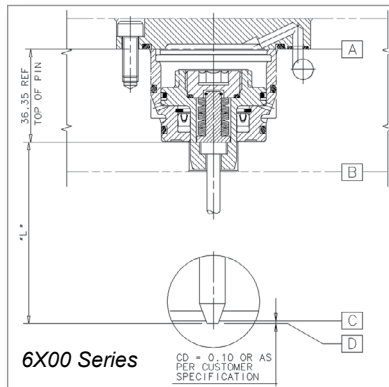


Figure 5-46 6X00 Series - Measure distance

5.14.7.3 7100 Series

1. Install the cylinder (where applicable) and piston bottom (without the pin and piston top) into the hydraulic plate.

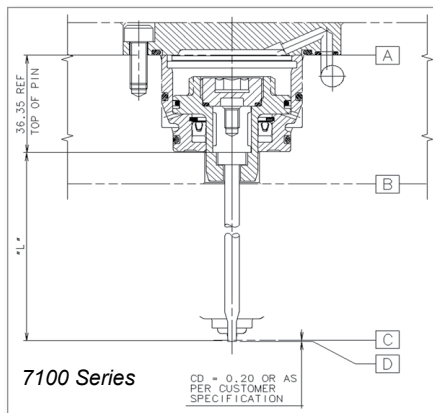


Figure 5-47 7100 Series - Measure distance

2. Measure the distance AC and BC.
3. Cut the pin to the length detailed in your general assembly drawing for your job.
4. Grind the valve pin tip to fit the cylindrical gate. Refer to the system gate detail.
5. Assemble the hydraulic unit.
6. Heat the Hot Runner system to processing temperature.
7. Soak the pin in the Hot Runner system for 10 minutes to achieve the maximum heat expansion of the pin at the processing temperature.

8. Turn on the mold cooling.
9. Measure the distance CD in the heated condition. Check that the head of the pin is seated.
10. Calculate the dimension to be ground (L2). $L2 = CD \text{ (measurement)} - CD \text{ (specified)}$.
11. Grind the pin end to remove L2 (finish cut).
12. If the gate vestige is critical, mold sample parts, measure the sample parts, and adjust the final pin length if necessary.

Steel quality in the gating area must have:

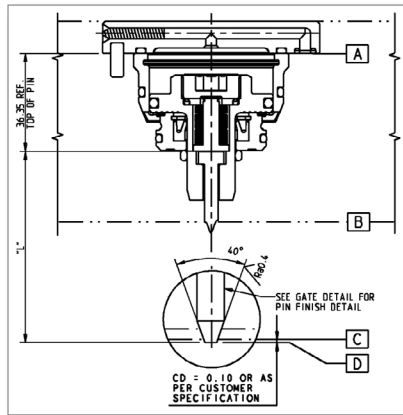
- Tapered gates - High grade of toughness (H13, 1.2344), hardness HRc 46-48
- Cylindrical gates - Minimum hardness HRc 54
- No nitration
- No chrome plating

The bottom of the nozzle well in the gate area must be free of stress caused by:

- Rough EDM
- Rough machining
- Sharp corners (JIG grinding is recommended)

5.14.7.4 8X00 Series

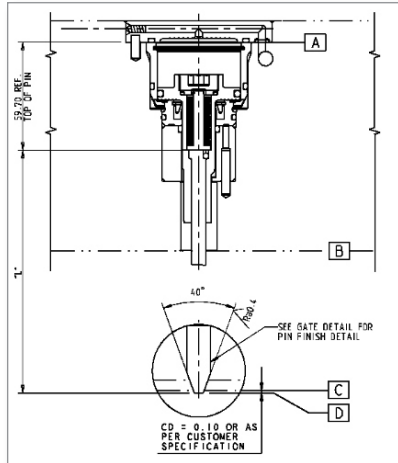
1. Lightly use silicone grease and install the O-ring in actuator plate at the bottom of the cylinder bore pocket.
2. Install the cylinder (where applicable) and piston bottom (without the pin and piston top) into the hydraulic plate.
3. Measure the distance AC and BC.



4. Cut the pin to the length detailed in your general assembly drawing for your job.
5. Grind the valve pin tip to fit the cylindrical gate. Refer to the system gate detail.
6. Assemble the hydraulic unit.
7. Heat the Hot Runner system to processing temperature.
8. Soak the pin in the Hot Runner system for 10 minutes to achieve the maximum heat expansion of the pin at the processing temperature.
9. Turn on mold cooling.
10. Measure the distance CD in the heated condition. Check that the head of the pin is seated.
11. Calculate the dimension to be ground (L2). $L2 = CD \text{ (measurement)} - CD \text{ (specified)}$.
12. Grind the pin end to remove L2 (finish cut).

5.14.7.5 8600

1. Insert anti rotation dowel into the actuation plate.
2. Insert the piston collar by aligning it with the anti rotation dowel.
3. Lightly use silicone grease and install the O-ring in piston collar in the cylinder bore pocket.
4. Install the cylinder (where applicable) and align the flat on the stem of the piston bottom with the flat in the piston collar (without the pin and piston top) into the hydraulic plate.
5. Measure the distance AC and BC.



6. Cut the pin to the length detailed in your general assembly drawing for your job.
7. Grind the valve pin tip at the angle detailed in your general assembly drawing for your job.
8. Lap the tip of the pin into the land area (steel section in the gate area) using a lapping guide bushing or valve bushing as a lapping guide. We recommend 400 - 600 grit lapping paste.
9. Assemble the hydraulic unit.

5.14.8 Lapping a Tapered Valve Pin—5500 and 6X00 Series



WARNING

Do not touch decomposing O-rings. Use appropriate protective clothing. Failure to do so can cause serious injury.



NOTE

The Viton O-rings used for the valve actuators are rated for operation below 200°C (400°F).

If the shut off between the valve pin and gate area is not satisfactory, lapping of the valve pin into the gate will be required. A support bushing that fits into the nozzle flange area should be manufactured with the pin diameter in the center of the support bushing to properly align the pin with the gate area (see below). Or use the nozzle well diameter of the cavity for the support bushing as a lapping guide.

1. Install the machined bushing with the center hole matching the pin diameter.
2. Insert the valve pin through the bushing.
3. Add 400 grit lapping paste to the tapered area of the pin and lap into the gate. Verify the shut-off with die spotting blue compound.
4. Be sure to remove all lapping paste from the valve pin and cavity, before continuing with actuator assembly.



CAUTION

Do not get lapping paste in the valve bushing bore. Failure to obey may cause damage to parts.



CAUTION

Always turn on the plate cooling prior to heating the Hot Runner system. Failure to obey may cause damage to parts.

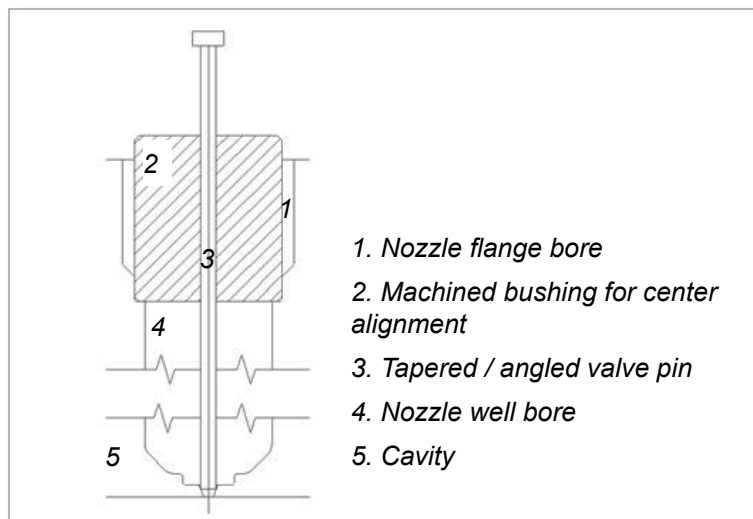


Figure 5-48 Bushing for pin lapping

5.14.9 Finishing the Head of a Valve Pin—5500 Series



WARNING - HOT SURFACES

Avoid contact with heated surfaces. Use appropriate protective clothing. Failure to do so can cause serious injury.

The standard stroke of the HY550* A/E is 4.0 mm (0.16 in.). This can be increased to a maximum of 8.0 mm by removing material from the piston top. The stroke of the HY550* C/F is 8.0 mm (0.31 in.) and must not be altered.

1. Heat the Hot Runner system to the processing temperature.
2. Allow the pin to soak in the Hot Runner system for 10 minutes to achieve the maximum heat expansion of the pin at processing temperature.
3. Turn on the mold cooling.
4. Measure the distance AB in heated condition.

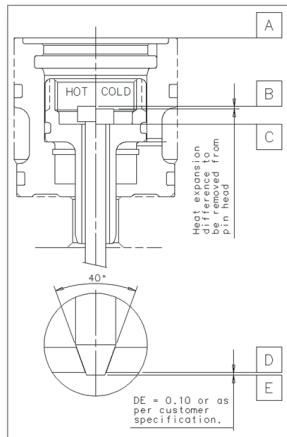


Figure 5-49 5500 Series - Measure distance

5. Remove the heat expansion difference from the pin head.
6. Check that the tip of the pin is fitted correctly into the land.

5.15 Valve Pin Assembly



CAUTION

For systems with Accu-Valve MX, Accu-Valve EX or Accu-Valve CX gate seals: Gate seals must be removed prior to installing valve pins.

5.15.1 5500 Series

1. Check the valve pin length. Refer to:
 - Finishing the Tip of a Valve Pin on page 5-43,
 - Finishing the Head of a Valve Pin—5500 Series on page 5-50.
2. Slide the valve pin into the piston.
3. Grease and install the O-ring.
4. Install the piston top and tighten, torque setting 20-27 Nm (15-20 ft-lb).

5.15.2 6X00 Series



CAUTION

Failure to install the disk springs in the correct order will cause damage to the gate.

1. Check the valve pin length. Refer Finishing the Tip of a Valve Pin on page 5-43.
2. Slide the valve pin into position.
3. Assemble the disk springs to the spring retainer stud.
 - a) Check for the correct orientation of the disk springs when installing.
 - b) 6500 Series: Align the springs in 5 alternating groups of 5, convex and concave.
 - c) 6600 Series and 6700 Series: Align the springs in 8 alternating groups of 6, convex and concave.
4. Install the disk spring assembly on top of the valve pin.
5. Grease and install the O-ring.
6. Install piston top and tighten, recommended torque setting 20-27 Nm (15-20 ft-lb).

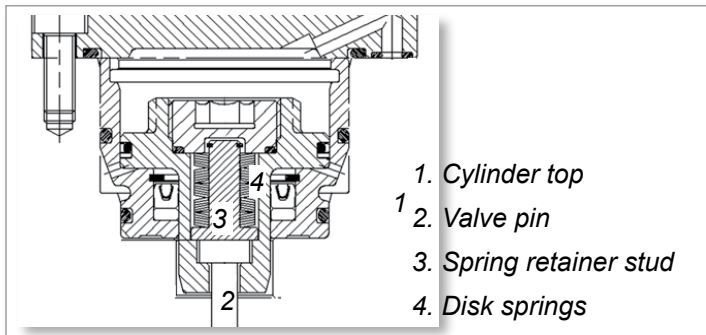


Figure 5-50 8 X 5 Disk spring assembly

5.15.3 7100 Series

1. Check the valve pin length.
2. Slide the valve pin into the piston.
3. Install the actuator spacer with the threaded side facing towards the piston top.



NOTE

The threaded side is used for removal or installation. Installing a screw into the spacer's threaded end allows for simple extraction of the spacer.

4. Grease and install the O-ring.
5. Install piston top and tighten to recommended torque setting 20-27 Nm (15-20 ft-lb).

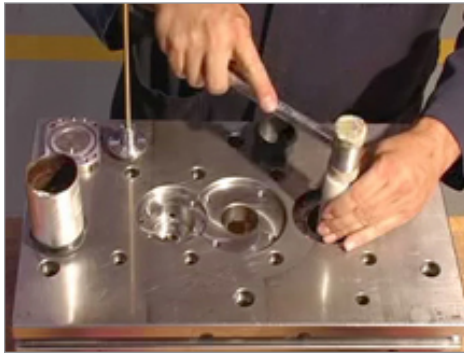


Figure 5-51 Cylinder installation



Figure 5-52 Piston spacer installation

5.16 Installing a Valve Actuator in a Hydraulic Plate



CAUTION

For systems with Accu-Valve MX, Accu-Valve EX or Accu-Valve CX gate seals, the gate seals must be removed prior to installing the valve pins.

5.16.1 5500 Series

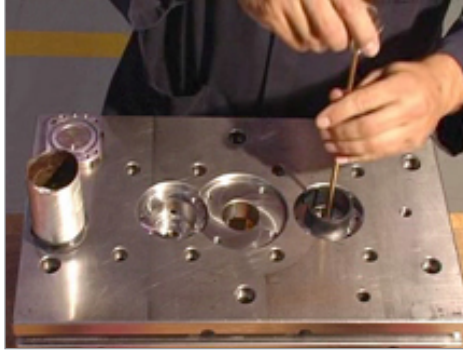


Figure 5-53 Valve pin and piston installation

The following procedure is for new systems:

1. Lubricate the sides of the actuator cylinder before installing into the hydraulic plate.
2. Make sure that there are no sharp edges on the hydraulic plate.
3. Tap the cylinder into the bore of the actuator plate with a nylon mallet.
4. Position the piston installation tool (PS0003TOOL01) on top of the cylinder.
5. Install the valve pin and piston into the cylinder bottom.

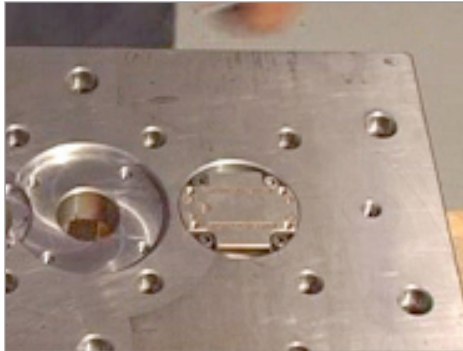


Figure 5-54 Cylinder top

6. Press the valve pin into position, using a nylon mallet to finish seating the valve pin into the assembly.
7. Install the piston top.
8. Remove the installation tool.
9. Check that the cylinder top dowel and O-rings are installed.
10. Install the cylinder top.

5.16.2 6X00 Series



CAUTION
Failure to install the disk springs in the correct order will cause damage to the gate.

1. Check the valve pin length. Refer Finishing the Tip of a Valve Pin on page 5-43.
2. Slide the valve pin into position.
3. Assemble the disk springs to the spring retainer stud.
 - a) Check for the correct orientation of the disk springs when installing.
 - b) 6500 Series: Align the springs in 5 alternating groups of 5, convex and concave.
 - c) 6600 Series and 6700 Series: Align the springs in 8 alternating groups of 6, convex and concave.
4. Install the disk spring assembly on top of the valve pin.
5. Grease and install the O-ring.
6. Install piston top and tighten, recommended torque setting 20-27 Nm (15-20 ft-lb).

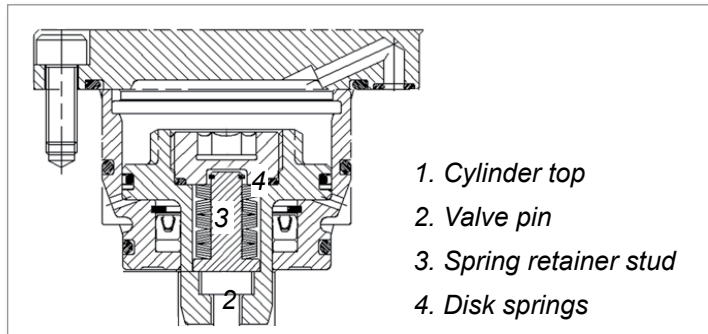
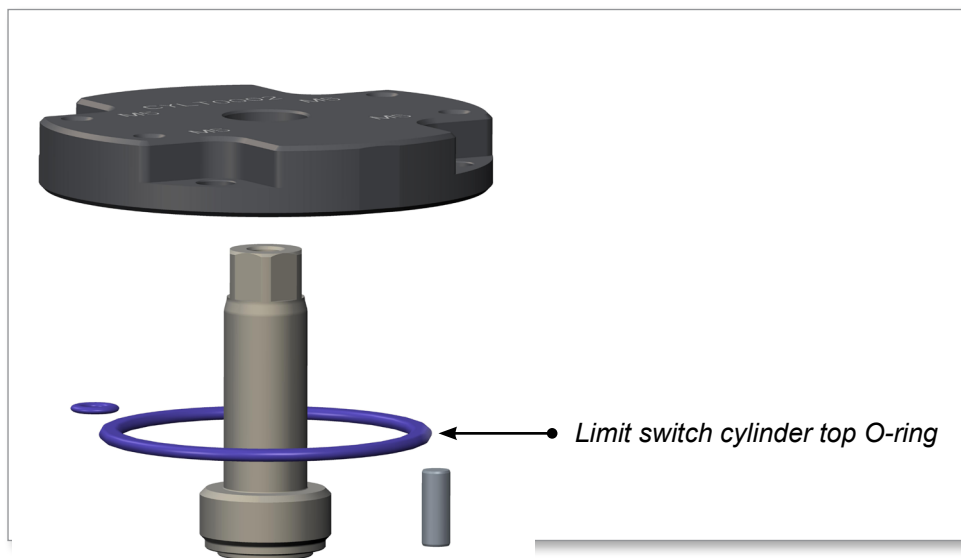


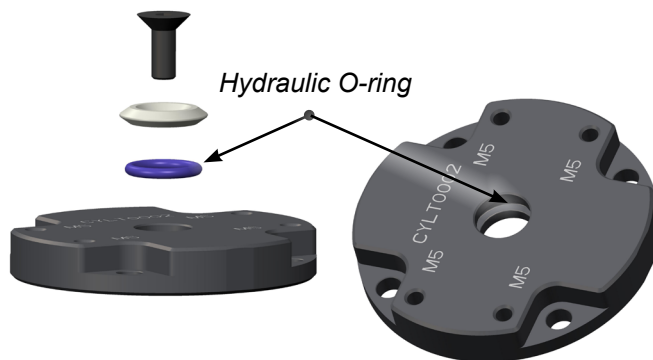
Figure 5-55 8 X 5 Disk spring assembly

5.17 Installing a Hydraulic Limit-Switch Option—6500 and 6600 Series

1. Lubricate the sides of the actuator cylinder before installing into the hydraulic plate.
2. Make sure that there are no sharp edges on the hydraulic plate.
3. Tap the cylinder into the bore of the actuator plate with a nylon mallet.
4. Position the piston installation tool (PS0003TOOL01) on top of the cylinder.
5. Install the valve pin and piston into the cylinder bottom.
6. Press the valve pin into position, using a nylon mallet to finish seating the valve pin into the assembly.
7. Remove the installation tool.
8. Check that the cylinder top dowel and O-rings are installed.



9. Install the hydraulic O-ring into the cylinder top.



10. Install the cylinder top. The piston top will protrude from the cylinder top.
11. Install the trigger ring on the head of piston top and lock its position with a flat head screw. Thread locking is recommended. (LOCTITE-243)

5.17.1 Installing a Proximity Sensor



CAUTION

Do not exceed the default torque value of 10 Nm (M8 screws) when installing a proximity sensor. Reduce torque values by 30% at the sensor's face. Failure to obey may cause damage to parts.



NOTE

The nominal sensing distance of the proximity sensor is 1.5 mm.

1. Before assembling the sensor into bracket hole, ensure that the assembly direction of the bracket part and cutout options are correct, based on stroke and gate position. See Figure 5-56 Single sensor / bracket assembly on page 5-56. Insert one proximity sensor into the metal bracket hole. Lock the position of the proximity sensor with the lock nuts. See 5.17.2 Cutout Options Based on Stroke for examples.
2. Install the bracket assembly over the cylinder top and lock its position with the socket-head cap screw.
3. Adjust the sensor's distance using lock nuts until the sensor detects the trigger ring, after which the LED light will turn on.
4. Repeat steps 1-3 to install the other bracket assembly into the cylinder top.

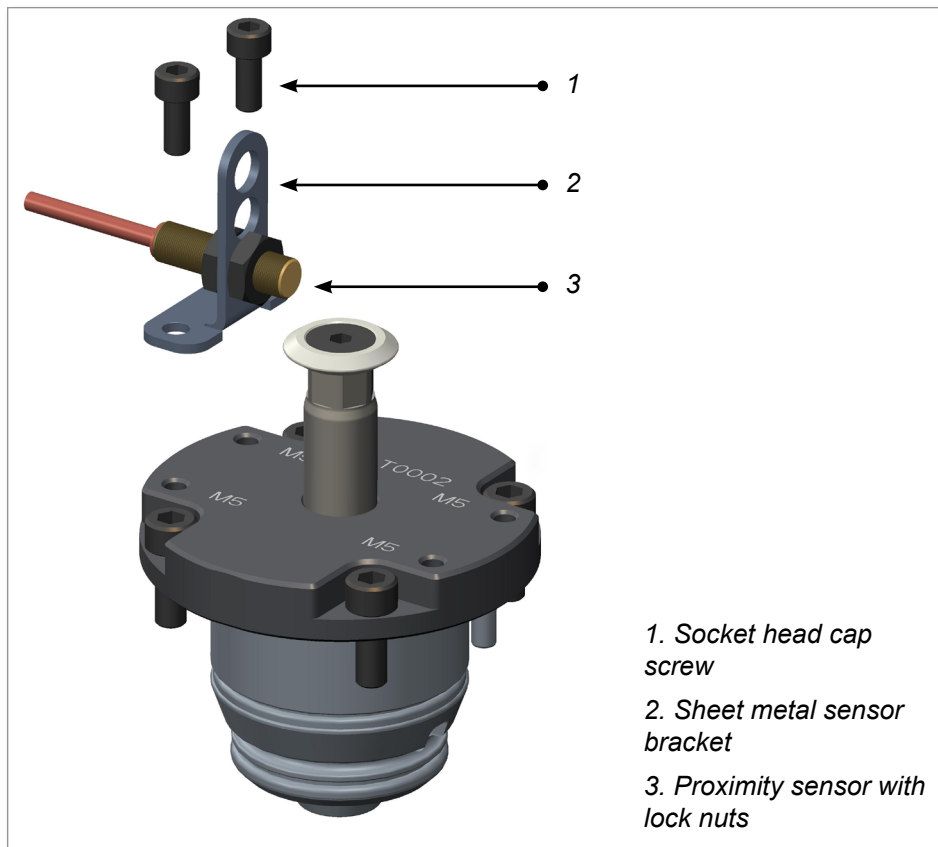
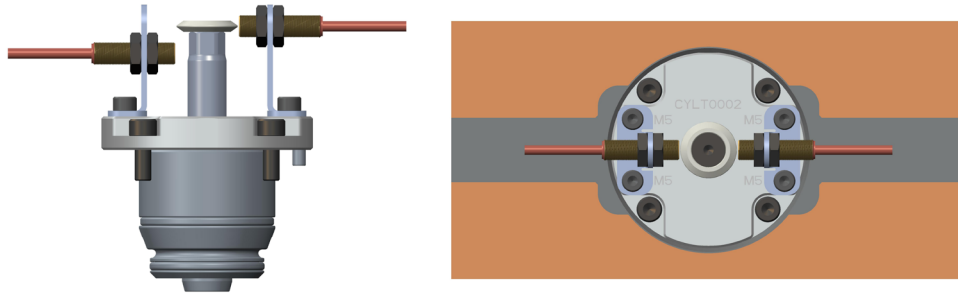


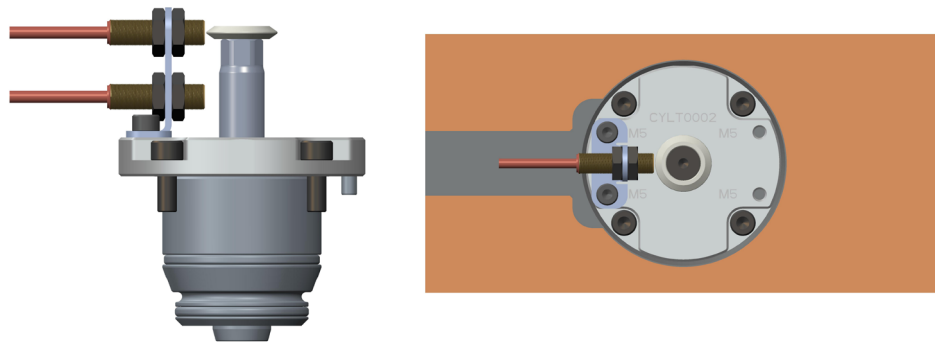
Figure 5-56 Single sensor / bracket assembly

5.17.2 Cutout Options Based on Stroke

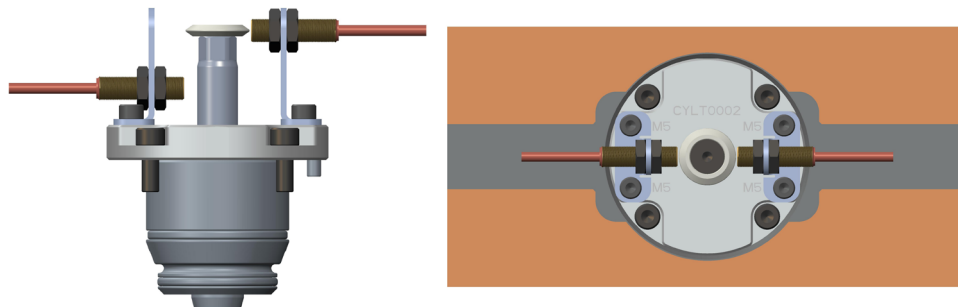
For 9.8 mm Stroke



For 19.8 mm Stroke - Option 1



For 19.8 mm Stroke - Option 2



5.18 Testing the Proximity Sensor of a Hydraulic Limit-Switch Option



WARNING

Use the appropriate protective clothing when you work with moving parts. Failure to do so can cause serious injury.



CAUTION

Excess voltage and current could damage the sensors. The voltage supply to a proximity sensor should be $< 30 V_{DC}$ and the output current should be $< 200 \text{ mA}$.



CAUTION

Make sure that the proximity sensor cables are free from mechanical devices which could damage them.



NOTE

The operating temperature of the proximity sensors is from -25 to 180°C (-13 to 356°F).

1. Make sure that the hydraulic system is completely assembled.
2. Apply a voltage of 10 to $30 V_{DC}$ to the proximity sensor. Make sure it is $< 30 V_{DC}$.
3. Operate the hydraulic actuator until the piston is in the closed position. Stop the hydraulic actuator at this position.
4. Adjust the sensor's distance using the lock nuts until the sensor detects the trigger ring, after which the LED light will turn on.
5. Operate the hydraulic actuator until the piston top is in the open position. Stop the hydraulic actuator at this position.
6. Adjust the second proximity sensor's distance using the lock nuts until the sensor detects the trigger ring, after which the LED light will turn on.
7. Disconnect the proximity sensor and the hydraulic actuator unit from the power supply.
8. If applicable, install the sensor plate with the screws as per the specification on your general assembly drawing.

5.19 SeVG Plus Actuator

Please see the Servo-Electromechanical Linear Actuator SE-108C user manual for details on the SeVG+ actuator.

5.20 E-Drive



WARNING - READ MANUAL

Read Section 3 - Safety on page 3-1 before assembling, integrating or operating the E-Drive system.actuators.

5.20.1 Typical System

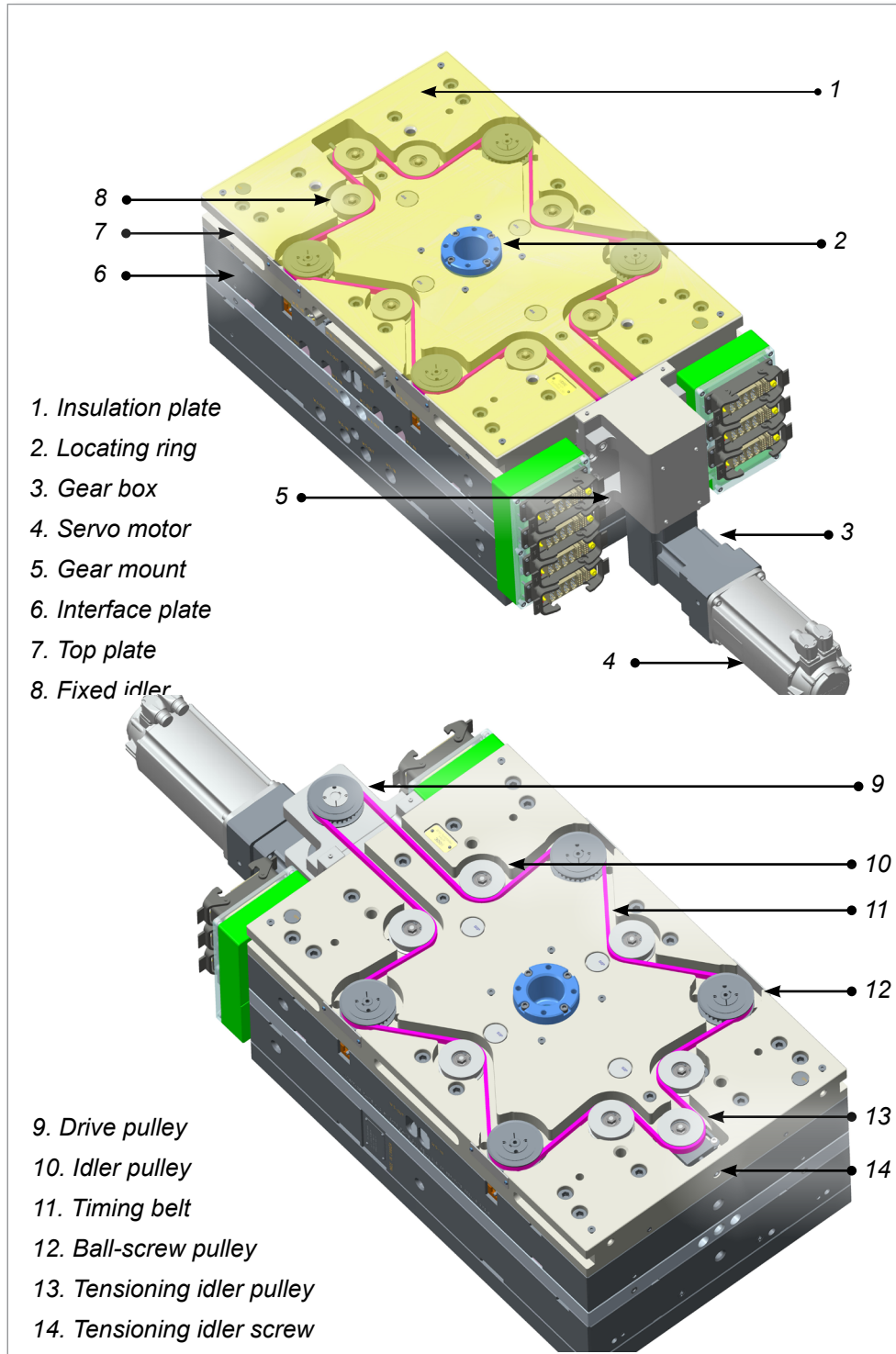


Figure 5-57 E-Drive system

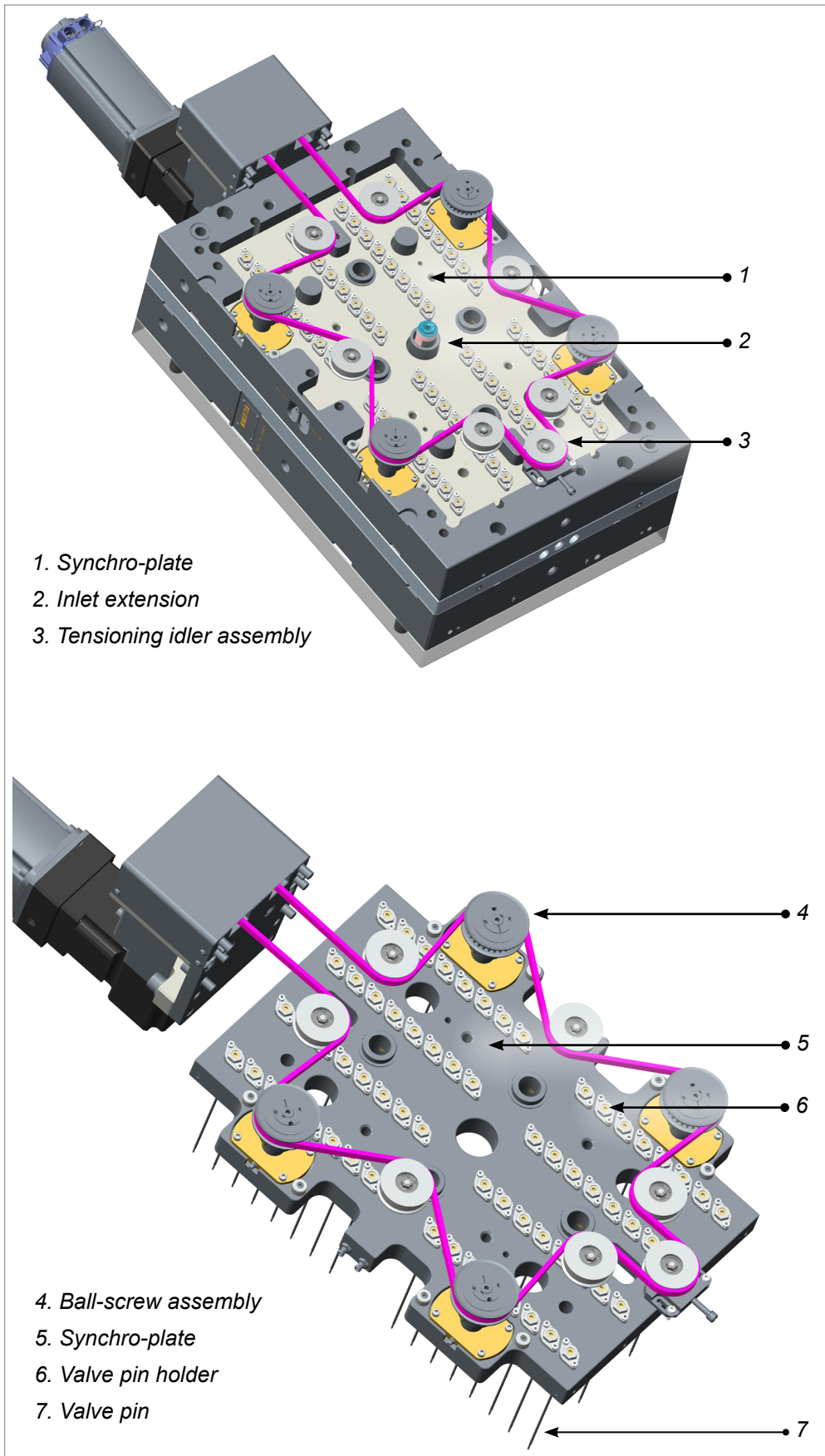


Figure 5-58 E-Drive system (continued)

5.20.2 Components

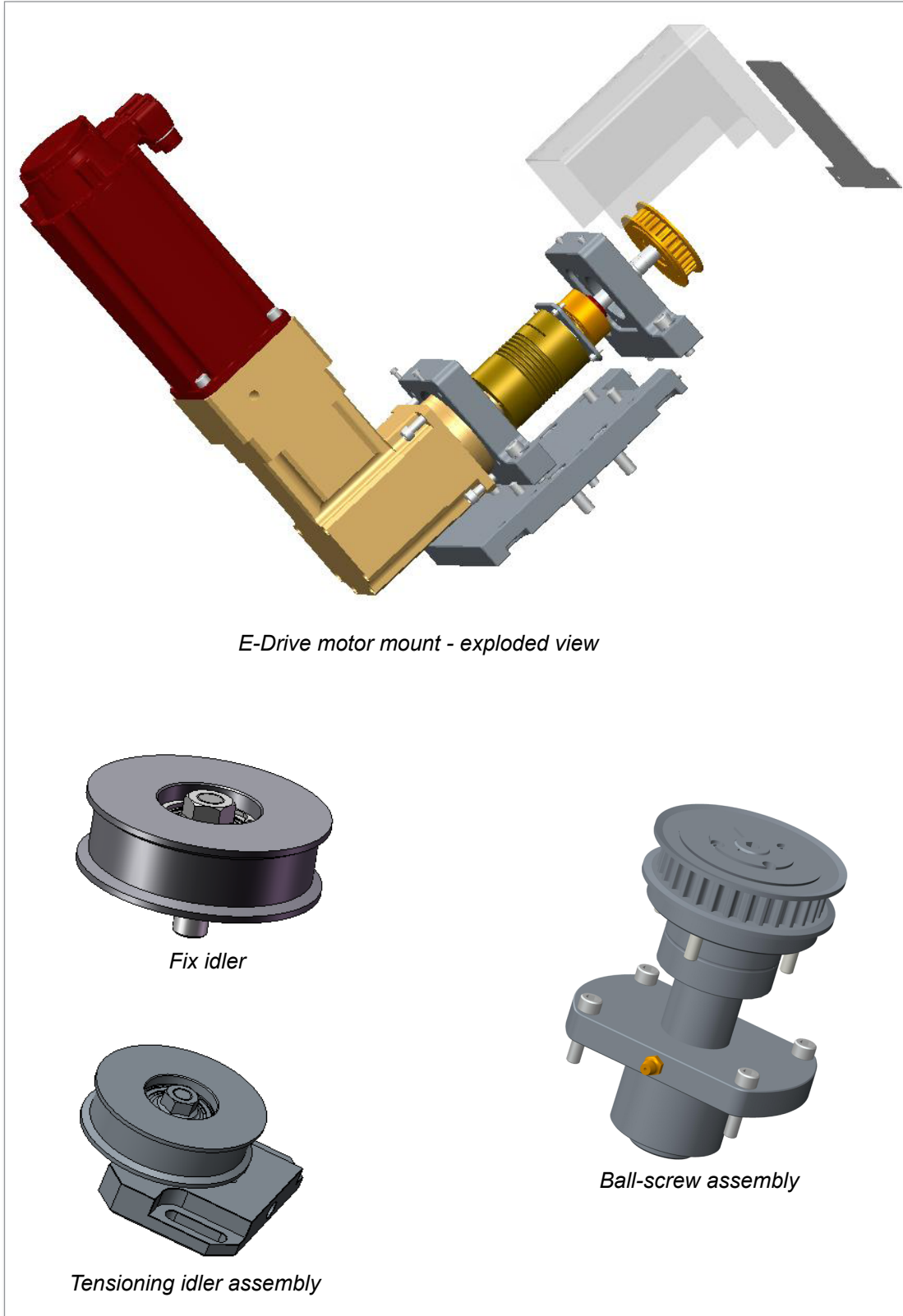


Figure 5-59 E-Drive components

5.20.3 Safety

Table 5-1 E-Drive Safety Hazards	
Hazard Area	Potential Hazards
	Mechanical Hazards
Entanglement Hazard	Do not operate the equipment with unconfined long hair, loose clothing or jewelry, including name badges, neckties, etc. These may get caught by the moving belt mechanism and can cause death or serious injury.
Entanglement Hazard During Maintenance	Always cover belt area with proper protecting sheet before any bench test or in-mold testing.
Electrical Hazard	Never touch or inspect the timing belt when power is on and E-Drive motor and controller are connected. Unplug the controller before any maintenance.
	High Voltage and amperage cables are connected to E-Drive controller (400VAC). Also there is high voltage cable connection between servo motor and controller. Heaters, servo motors and electrical components in the controllers could come in contact with a person. Always disconnect and use proper lock out procedures before performing any maintenance work.
Trip Hazard	Controller cables are a tripping hazard on the floor between the controller and the mold.
	Combination Hazards
Failure / Disorder of Control System	Mixed-up connections of the motor power cables on dual motor units may result in an out-of-control or unexpected movement causing damage to the machine and a possible hazard should the machine fail.
	Do not swap E-Drive controllers for different E-Drive systems without checking manual as controller setup must match mechanical system as it may result in an out-of-control or unexpected movement causing damage to the machine and a possible hazard should the machine fail.



WARNING - READ MANUAL

Carefully read the instructions before operating equipment. If in doubt, contact Mold-Masters for clarification.



CAUTION

Do not hot-plug the motor. Make sure the controller power supply is unplugged or turned off before plugging in the cables of the motor. Otherwise, damage can be caused to the motor.



CAUTION

Do not heat the Hot Runner system without connecting a proper cooling system. E-Drive components are rated to operate at temperatures less than 0°C (104°F). If your application mold temperature needs to be set above 40°C (104°F), use mold design for higher temperatures.

5.20.4 Assembly



WARNING - READ MANUAL

Read Section 3 - Safety on page 3-1 before performing any assembly procedures.

The Mold-Masters E-Drive system is shipped pre-assembled and requires minimal pre-installation assembly. The following details the assembly / installation procedures for various components of the E-Drive.

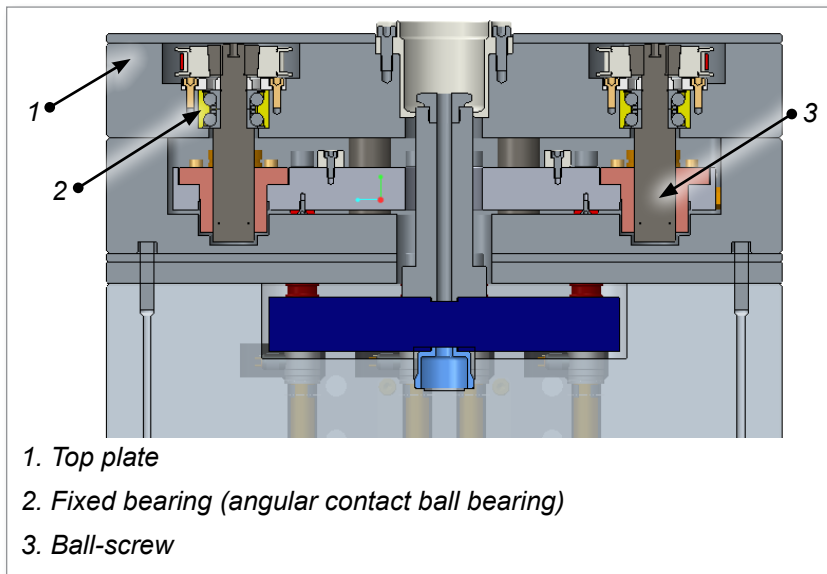
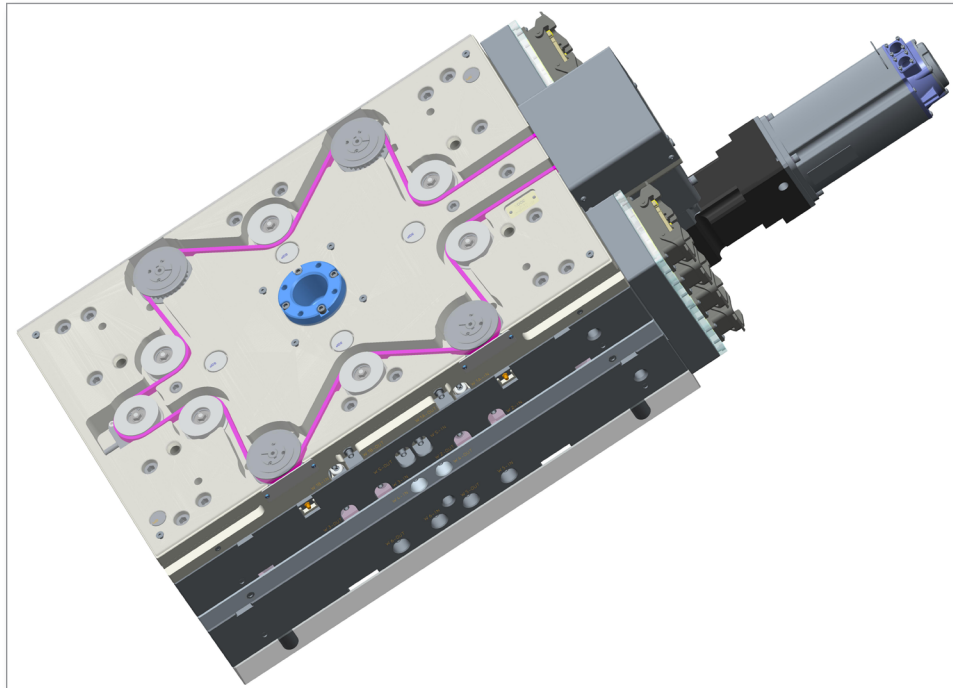
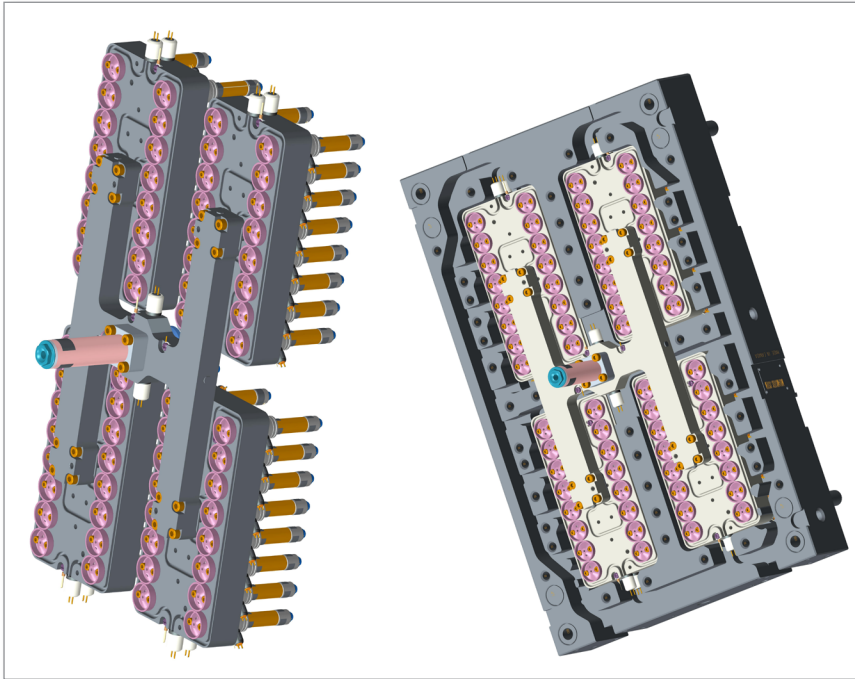


Figure 5-60 Complete assembly (center section)

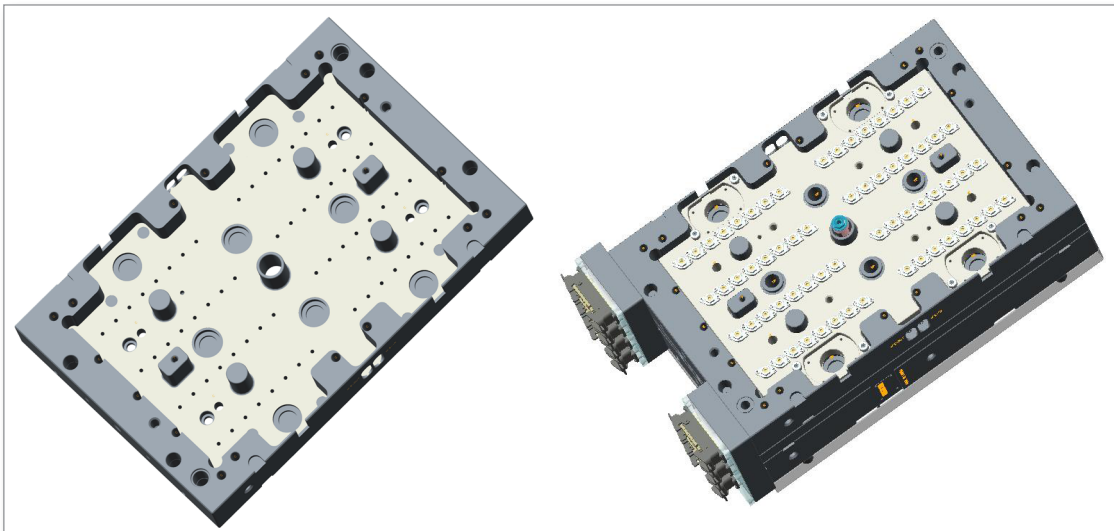
5.20.5 Attaching a Hot Runner Assembly

1. Attach the Hot Runner system to the manifold plate.



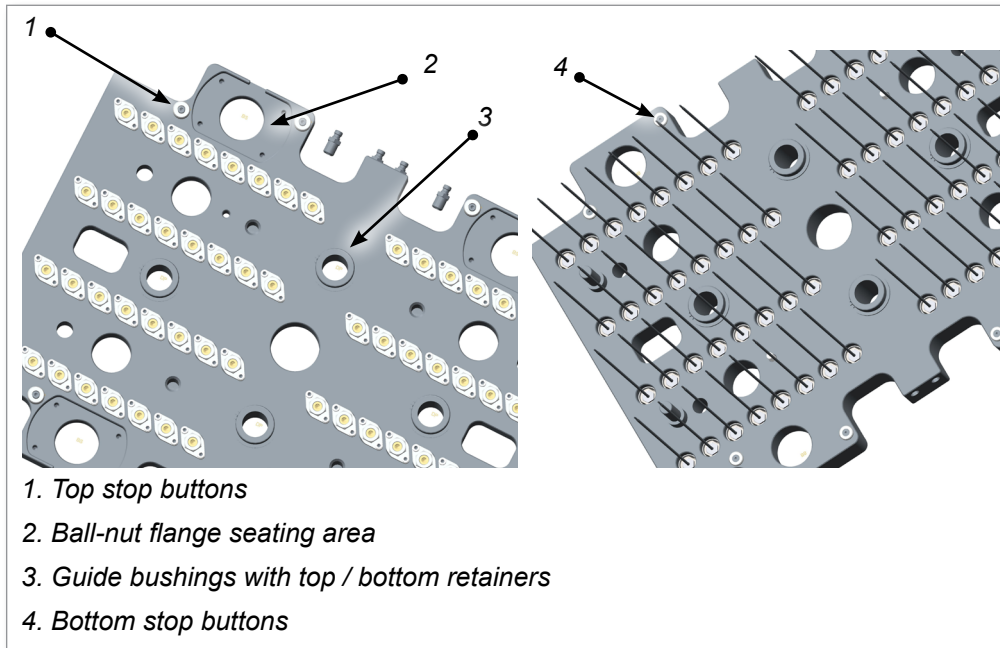
5.20.6 Attaching a Plate Assembly

1. Attach the interface plate to the manifold plate.
2. Install the fastening screws to join the plates.

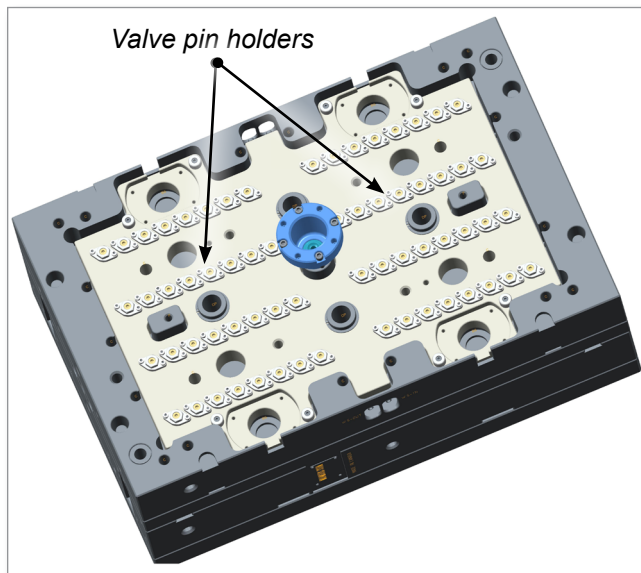


5.20.7 Assembling a Synchro-Plate

1. Install the synchro-plate without ball nuts into the cutout of the interface plate.

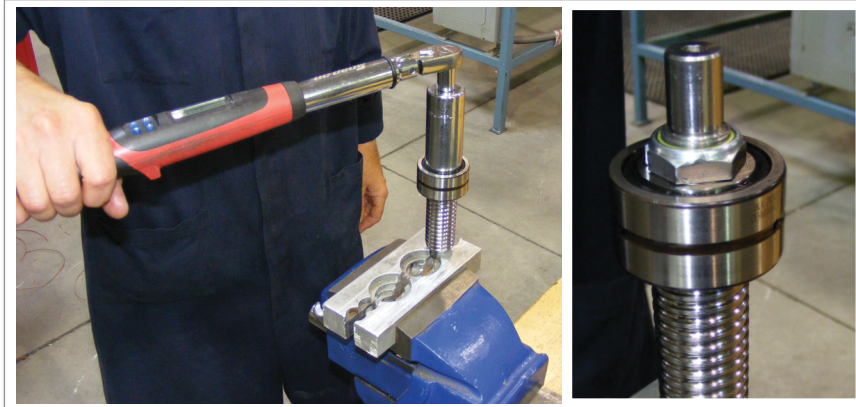


2. Install the valve pin holders into the synchro-plate.



5.20.8 Preparing a Ball Screw

1. Assemble the ball-screw and fixed bearing.
2. Tighten the ball-screw nut (M20 x 1.0) to 43-45 Nm (31.7 to 33.1 lbf-ft).
3. Make sure that the bearing is properly seated.



5.20.9 Lubricating a Ball Screw



WARNING

The lubricant contains hazardous chemicals. Wear proper gloves and a face mask when you apply lubricant to the ball-screws.

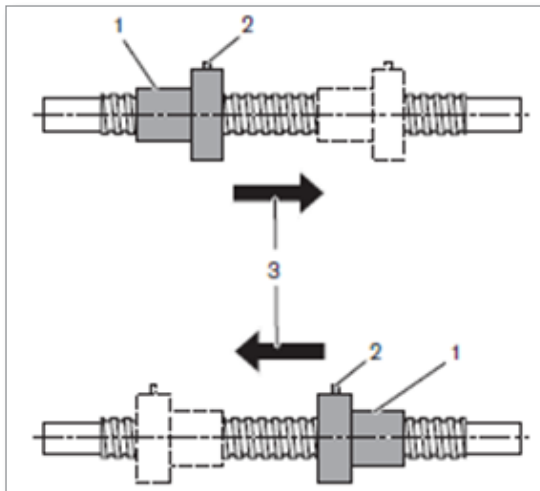


CAUTION

Do not install the ball screw without lubrication. Keep dirt out of the ball screw. Installing the ball screw without lubrication may damage the ball screw.

Mold-Masters recommends that you use the lubricant Tribol GR 100-2PD. This lubricant can be ordered from Mold-Masters. Do not use graphite- or MoS₂-based lubricants as these lubricants will reduce the lifetime of the ball screw.

1. Move the ball screw nut to one end (position 1) of the spindle.
2. Use a grease gun and apply approximately 3 g of grease into the ball screw nut.
3. Move the ball screw to the other end (position 2) of the spindle, and move the ball screw back to position 1.



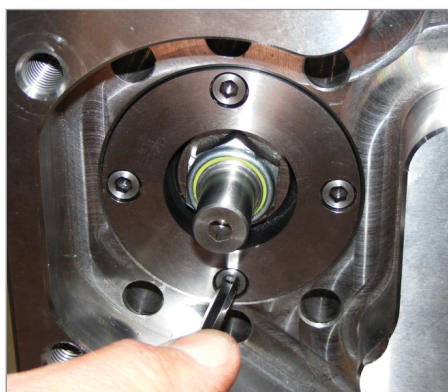
5.20.10 Assembling a Ball Screw

Ball-screw mounting kit EDRIVEBSMNTKITP is supplied with the system.

1. Assemble the ball-screw to the top plate (press-fit). Bearing will protrude 0.10 mm (0.004 in.) to seal with the cover.



2. Install the cover plate into position.



3. Assemble ball-nut on ball-screw with a torque of 43-45 Nm (31.7 to 33.1 lbf-ft).



5.20.11 Maintaining a Ball Screw



CAUTION

If your mold has not been used for a long time, inspect the ball screws for oxidation and dirt. Clean and lubricate the ball screws before you start the machine. Failure to do so may cause damage to the ball screws.

We recommend that you have a Mold-Masters service technician do the inspection.

Regular Maintenance Recommendations:

Maintenance by cycle: Every 1.6 million cycles.

Maintenance by duration: Every six months.

Mold-Masters recommends to carry out the maintenance on whichever schedule occurs earlier.

5.20.12 Assembling a Top Plate

1. Make sure that the flange-nuts are at proper orientation and same level before top-plate is lowered down for assembly.
2. Install the top plate with the ball-screw to the synchro-plate.
3. Install the motor and the gearbox to the unit.
4. Install the tension idler pulleys to the top plate.

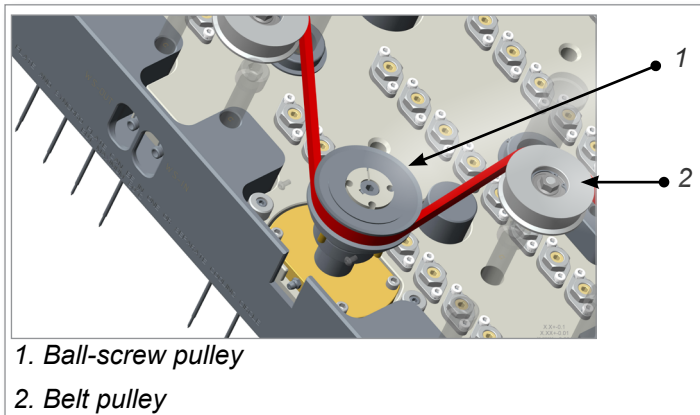
5.20.13 Attaching a Synchro-Plate to a Top Plate Assembly

1. Using tool KEY-BPHEXTKEY5.0, place the M6 screws that connect the ball-nut to the synchro-plate and slightly tighten them. Use another hex key tool and fully tighten the screws.

5.20.14 Assembling a Tension Belt

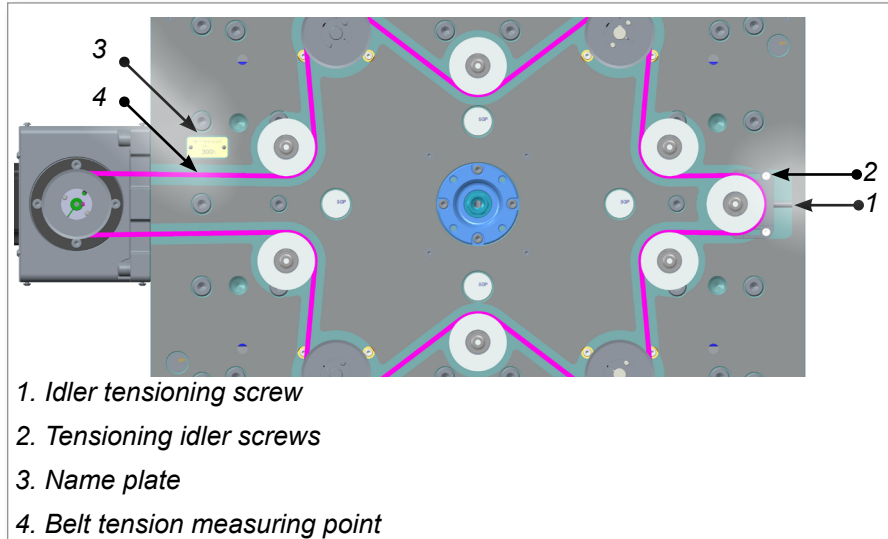
For the first installation of the belt, see section 5.20.19 on page 5-72.

1. Install the ball screw pulleys and belt on the top plate assembly.
2. Do not lock the belt pulley to the screw shaft. Make sure that the shaft does not rotate when the pulleys are rotated.

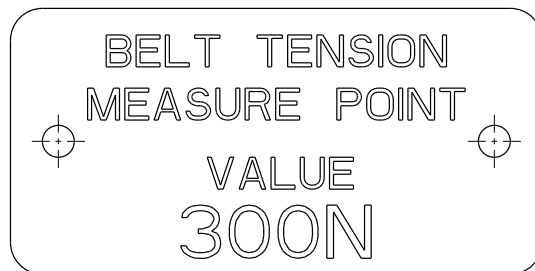


3. Fasten the tension belt to the pulleys.

4. Tension the belt with the idler tensioning screw to 300 N (67 lbf). Measure the tension in the belt as follows: Use a Sonic tension meter and follow the Span vibration tension method to measure the belt tension. Measure the belt tension in the longest distance between two pulleys. In your system, the longest distance is the point on the belt that is next to the name plate.



- a) Enter the values of belt density, width and span length to the Sonic tension meter. Refer the name plate for the required information.
 Belt density (M) : 004.7 g/m (fixed value)
 Belt width (W) : 012.0 mm/R (fixed value)
 Span length (S) : Variable value, see timing belt selection page



- b) Tap the longest belt span.
 - c) Press the “measure” button on the sonic meter and hold the microphone at 1/4 in. away from the back of the belt.
 - d) Check the tension and span vibration frequency values in the meter. If required, adjust the tensioning idler screw and make sure that the tension in the belt is 300 N (67 lbf).
5. Tighten the tensioning idler screws.

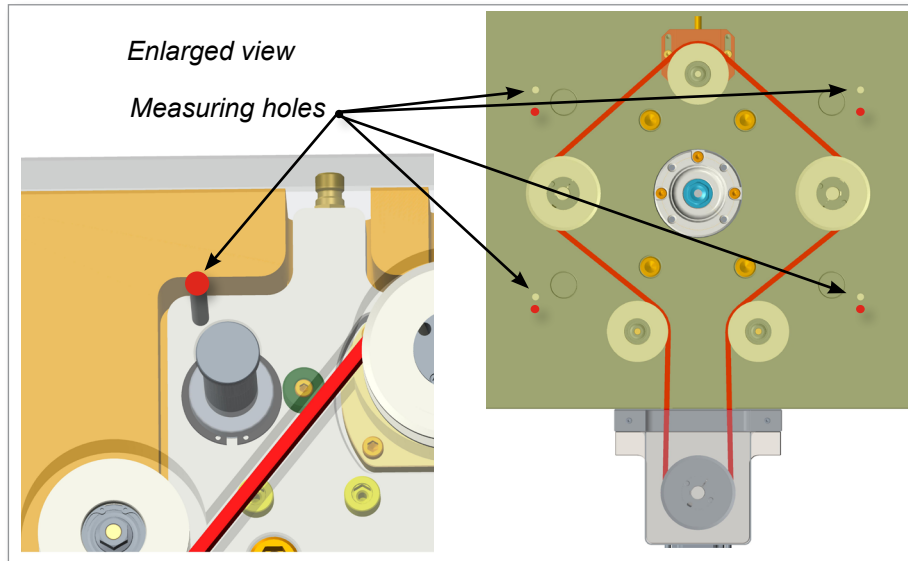
5.20.15 Inspecting the Parallelism of the Synchro-Plate



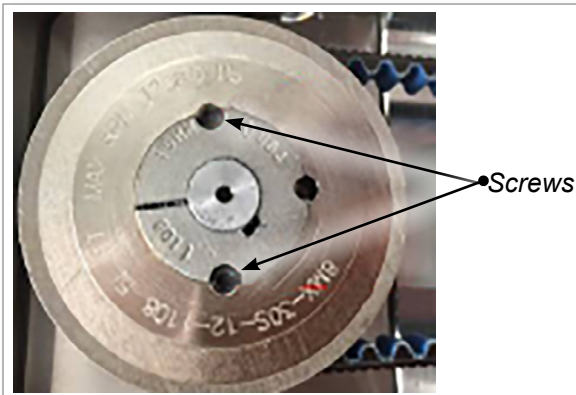
CAUTION

Do not run the E-Drive when the synchro-plate is not in the parallel position. Doing so will damage parts.

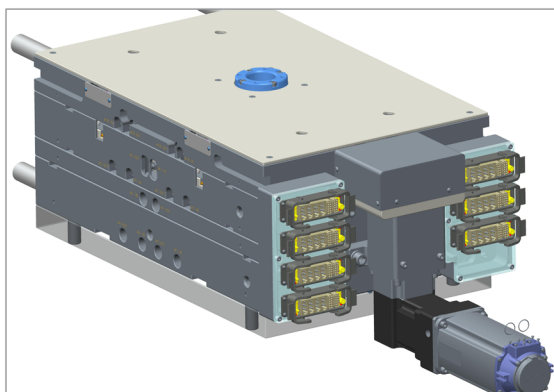
1. Use the depth gauge tools and inspect the parallelism with the help of the measuring holes provided in the system.



2. Once the parallelism is confirmed, tighten the screws (2 Nos) in each ball-screw pulley.



5.20.16 Assembling an Insulation Plate and a Locating Ring



5.20.17 Doing E-Drive Controller Checks

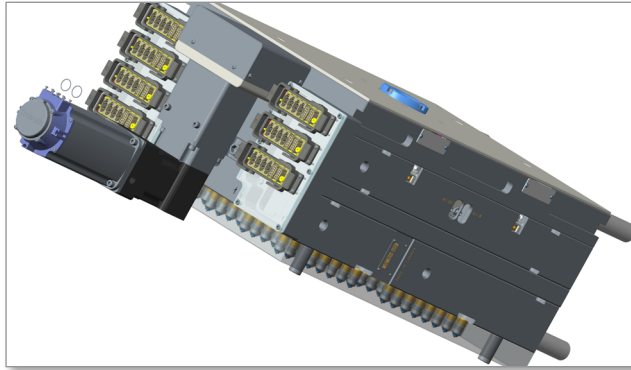
Do the procedures in the E-Drive controller user manual and do the E-Drive controller checks.

5.20.18 Installing a Hot Half in a Mold



CAUTION

Make sure the synchro-plate valve pins are at the open position before shipping.



5.20.19 Installing or Replacing a Belt

1. If system is new and no plastic is inside, move the synchro-plate to home position (fully open position). With proper hex keys on top of ball-screws, rotate clockwise. If system has run plastic before, make sure you heat up the system before moving the synchro-plate to fully open position. In such a case, attach cooling lines to cooling system and make sure that mold temperature will not exceed 40 °C (104 °F) for E-Drive plates.

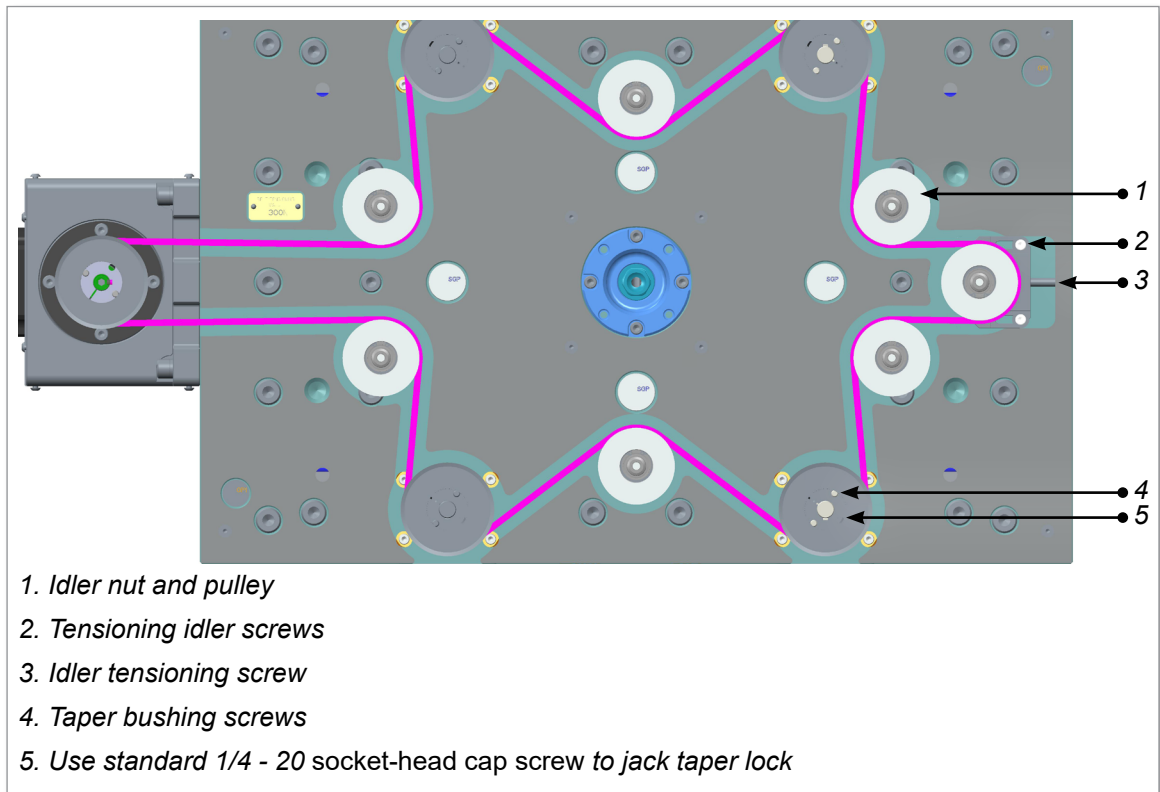


Figure 5-61 Installation or replacement of the belt

2. Remove tension from belt completely from tensioning idler.
3. Loosen nuts above one idler without teeth and remove the idler pulley, to allow inserting the belt in tight-belt conditions.
4. Remove the taper bushing set screws on top of both ball-screw pulleys (1/4-20 UNC).
5. Use another standard 1/4-20 socket-head cap screw to jack the pulley until it releases. Make sure that the synchro-plate remains fully up and seated flat.
6. Replace the belt.
7. Put back the idler without teeth and tighten the nuts.
8. Install the taper bushing allowing the pulley to still rotate (not gripping yet).
9. Apply slight tension to engage two pulleys (check elevation of pulleys).
10. Time both ball-screw pulleys to engage in same way.
11. Tighten the taper bushing set screws on top of ballscrew pulleys. Make sure the pulleys are at proper elevation and synchro-plate remains flat and seated. Do not apply more than 0.56 Nm (80 lb-in) torque to the set screws.
12. Tension the belt with the idler tensioning screw to 300 N (67 lbf).

**NOTE**

S5.20.14 Assembling a Tension Belt on page 5-69 has instructions on measuring the tension in the belt.

13. Tighten the tensioning idler screws.
14. Do the same in all the ball-screws.
15. Check belt height all around and make sure it is in middle of all pulleys and not rubbing on sides. Measure depth of belt at various places and check alignments.
16. If possible, while system is heated, do a few dry cycles (using 24 V_{DC} manual trigger) and check movement and noise. Double check the position of belt within all pulleys. See E-Drive Controller Operating Manual.

5.20.20 Doing a Check for Misalignment

During belt installation and drive alignment, two types of misalignment can occur:

- Parallel misalignment - is when driveR and driveN shafts are parallel, but the two pulleys lie in different planes.
- Angular misalignment - is when the two shafts are not parallel.

A fleeting angle is the angle at which the belt enters and exits the pulleys, and it equals the sum of the parallel and angular misalignments.

Any degree of pulley misalignment will result in some reduction of belt life, which is not accounted for in the normal drive design procedure. Misalignment of all positive belt drives should not exceed $1/4^\circ$ or 5 mm per metre of centre distance.

Misalignment should be checked with a good straight edge tool. The tool should be applied from driveR to driveN and from driveN to driveR so that the effect of parallel and angular misalignment is taken into account.

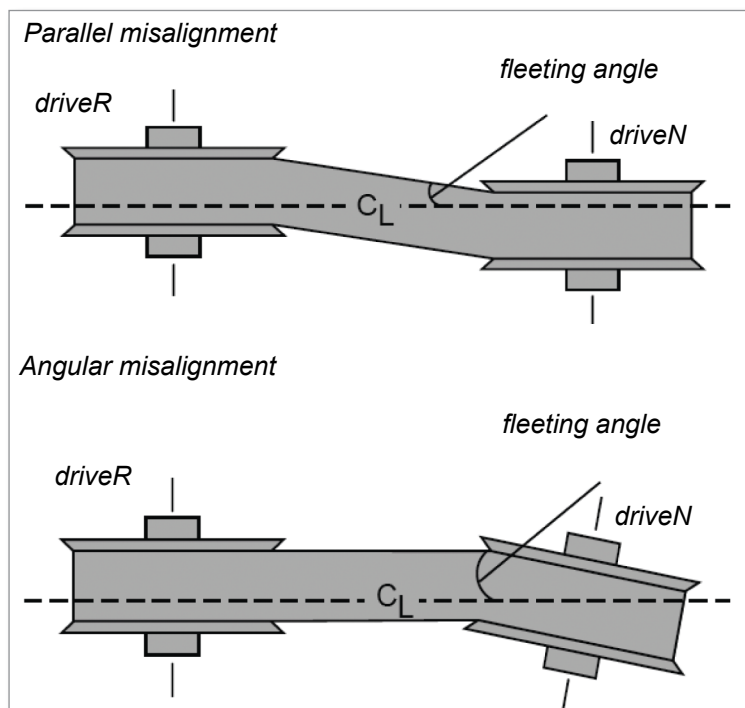


Figure 5-62 Misalignment check

5.21 Mag-Pin Option



WARNING

Ensure that you have fully read Section 3 - Safety on page 3-1 before assembling or installing the Mag-Pin option.

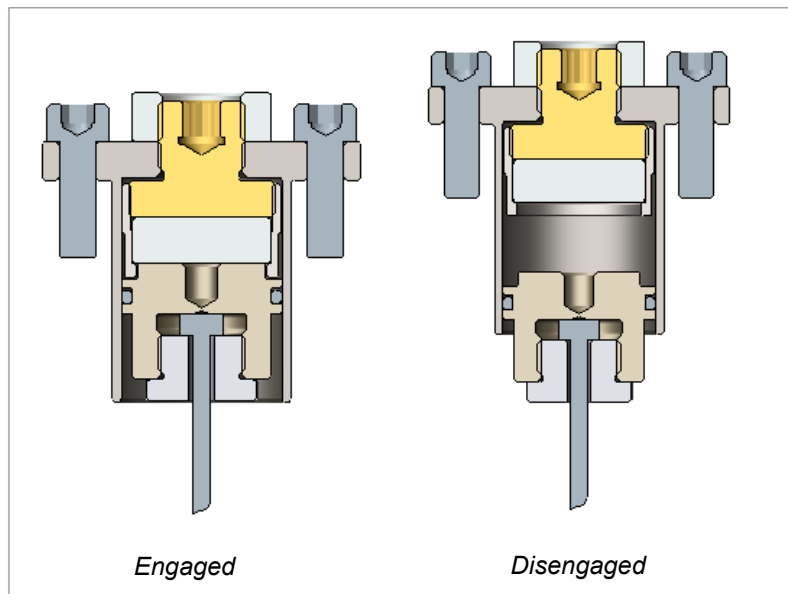
This section provides the information for the assembly / installation of the Mag-Pin (Magnetic Valve Pin holder) which is an optional component.

The Mag-Pin mechanism helps in the deactivation of individual valve pins in the synchro-plate design. The advantage of this system is that the mold plates do not need to be open to do this. A deactivated valve pin will remain in the closed position. This provides the ability to select and shut down any cavity in a synchro-plate design.



CAUTION

Deactivation of the magnets must be only used as a temporary solution.



Do not use the Mag-Pin option for the conditions that follow:

- To mold soft and elastic materials with Durometer hardness (Style A) less than 90 (for very short length nozzles in particular)
- To mold viscous materials with long nozzles
- Accu-Valve CX gate style

To use the Mag-Pin option, consider the factors that follow:

- Plastic material
- Nozzle length
- Valve pin size: 2.5 and 3 mm (0.1 and 0.12 in.) diameter valve pins
- Gate style



NOTE

To determine whether the Mag-Pin option is applicable to your product, please contact Mold-Masters.

5.21.1 Assembly

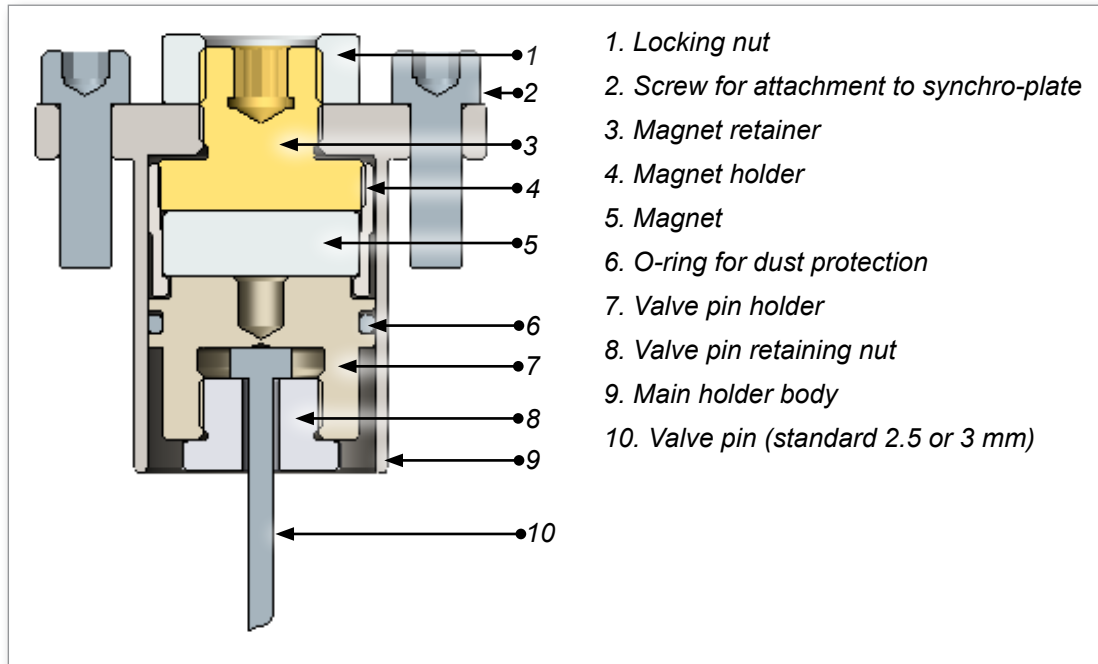


Figure 5-63 Mag-Pin assembly

5.21.2 Safety



WARNING - STRONG MAGNETIC FIELD HAZARD

People with pacemakers or other metallic, electronic, magnetic implants, devices or objects should not enter the magnetic field. Failure to do so may cause serious injury or death.



CAUTION - STRONG MAGNETIC FIELD HAZARD

Do not keep any tools or metal objects in the magnetic field. Failure to obey may cause damage to parts.



Figure 5-64 Mag-Pin safety hazards

5.21.3 Operation



CAUTION

Do not turn off the nozzle. Doing so may cause leaks.

Normal condition:

- Nozzle is at processing temperature and the gate is active.
- Force of the magnet is high enough to hold the valve pin that is attached to the synchro-plate when the cycle opens.

Deactivated gate:

- With the valve pin in close position, decrease the temperature until the plastic material is frozen. This low temperature plastic around the valve pin holds the pin in the closed position.
- The valve pin separates from the synchro-plate at the magnet interface.

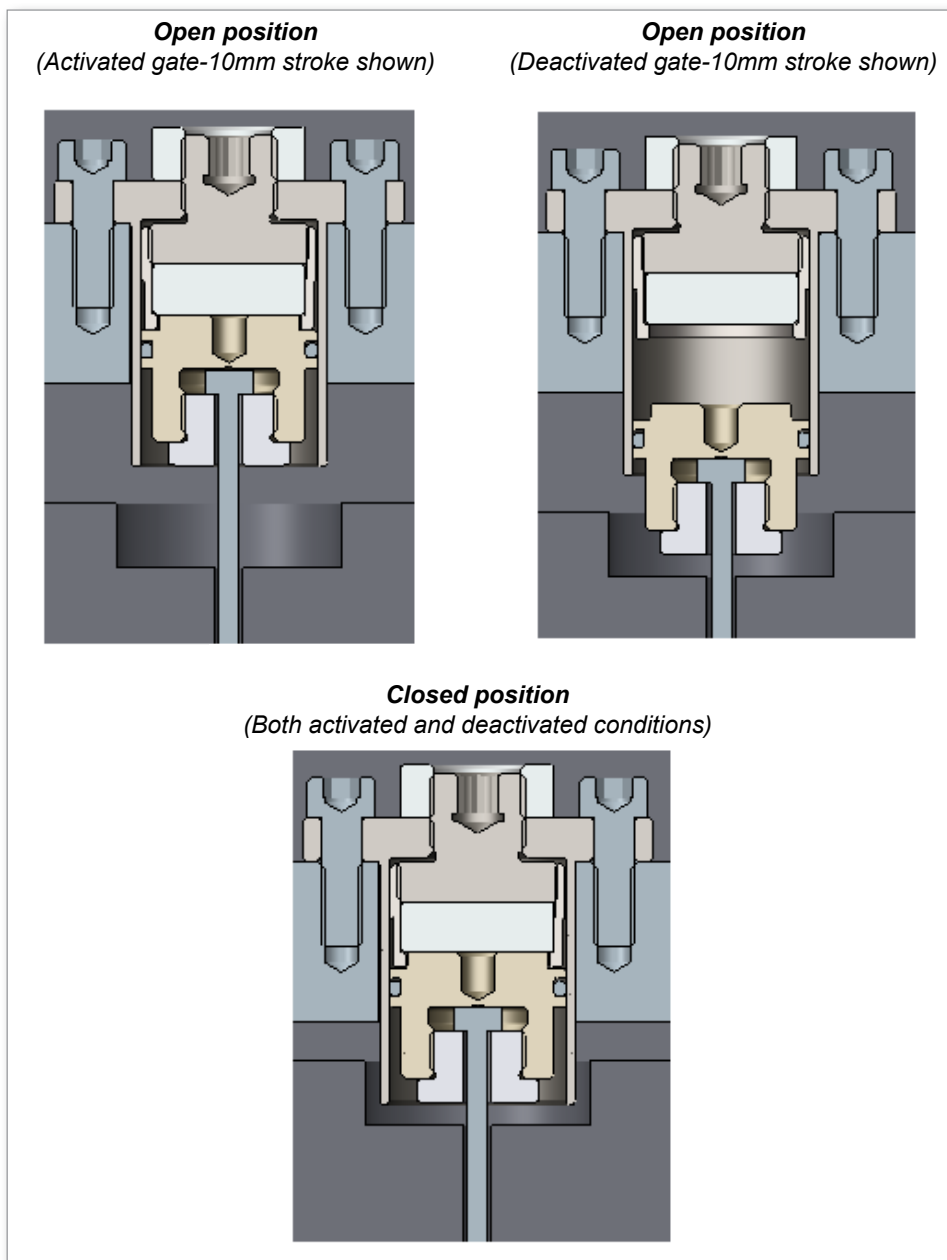


Figure 5-65 Mag-Pin activation / deactivation

Deactivation:

After the nozzle temperature is dropped down, the plastic material around the valve pin holds the pin in its position and it decouples at the magnet interface.

Activation:

After the nozzle is turned on, the plastic material around the valve pin releases the pin and the magnet is engaged at the interface when the actuation starts.

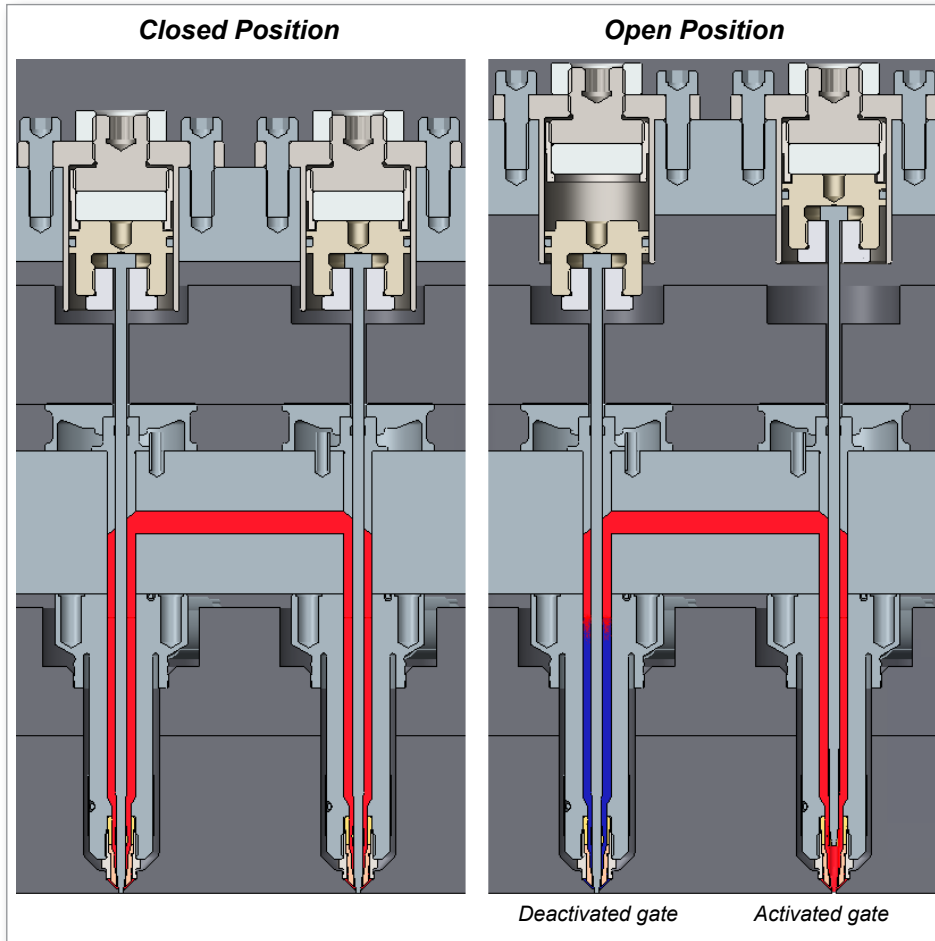


Figure 6-3 Mag-Pin activation / deactivation (continued)

5.21.4 Handling Magnets



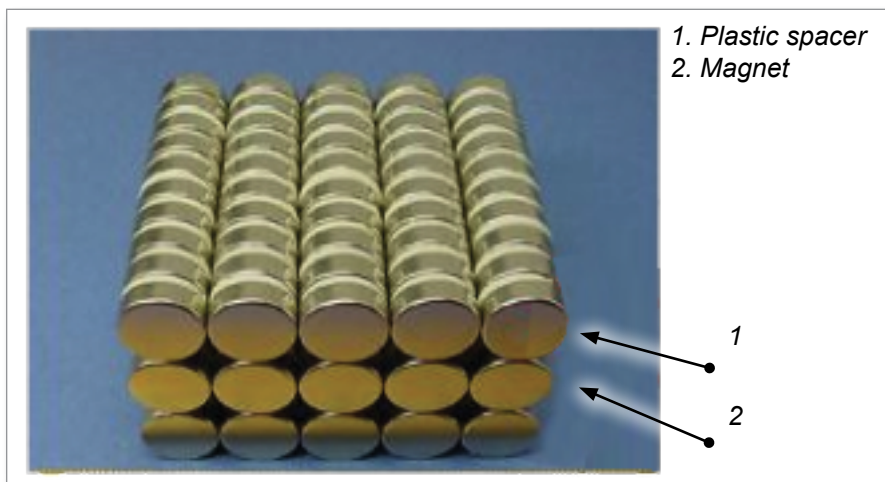
WARNING - PINCH HAZARD

Be careful of pinch hazards when you handle the magnets. Failure to do so may cause serious injury or death.



CAUTION

Keep groups of magnets in a thick plastic container to avoid impact with other parts or tools. Use the supplied plastic spacers between the magnets to prevent contact between them when you handle and store the magnets.



5.21.5 Summary of the Assembly Procedure

1. Placing a Magnet on Top of the Magnet Retainer on page 5-80
2. Checking the Polarity of a Magnet on page 5-81
3. Cleaning a Magnet Holder on page 5-81
4. Installing a Magnetic Retainer in a Magnet Holder on page 5-82
5. Placing a Magnet Holder and Magnet into a Housing on page 5-82
6. Assembling a Nut and a Lock Magnet Holder on page 5-83
7. Installing a Valve Pin in a Valve Pin Holder on page 5-83
8. Installing an O-Ring in a Valve Pin Holder on page 5-84
9. Installing a Valve Pin in a Housing Assembly on page 5-84
10. Installing a Mag-Pin Assembly in a Synchro-Plate on page 5-85

5.21.6 Assembling



WARNING - PINCH HAZARD

Be careful of pinch hazards when you handle the magnets. Store the magnets in a safe and thick plastic container. Failure to do so may cause serious injury or death.



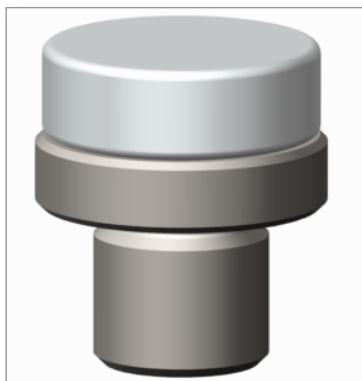
CAUTION

Make sure that the work bench is free from metal chips, debris, dust, and grinding powder.

Do not place the magnets close to any ferromagnetic parts or other magnets. Their light weight and magnetic strength can cause the magnets to collide which will damage the magnet faces.

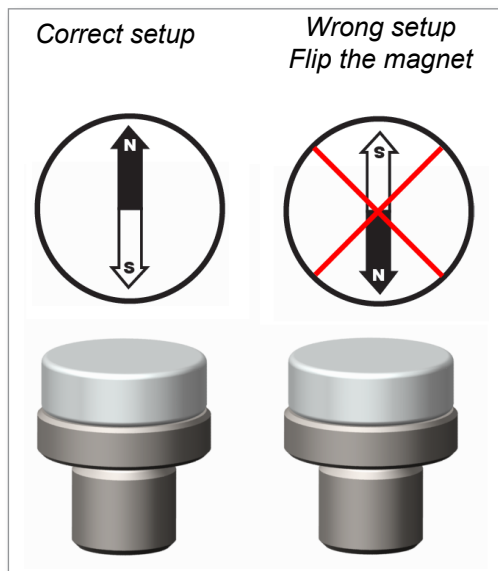
5.21.6.1 Placing a Magnet on Top of the Magnet Retainer

1. Install the magnet on top of the magnet retainer.



5.21.6.2 Checking the Polarity of a Magnet

1. Use a compass to check the polarity of magnets before assembly. Flip the magnet if the polarity shown on the magnet is wrong.



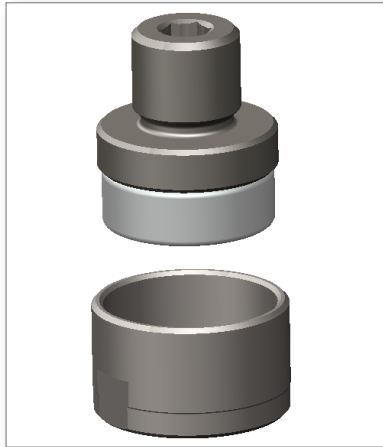
5.21.6.3 Cleaning a Magnet Holder

1. Clean and inspect the magnet holder.
2. Make sure that the interface with the magnet is free from grease, burrs or dust.



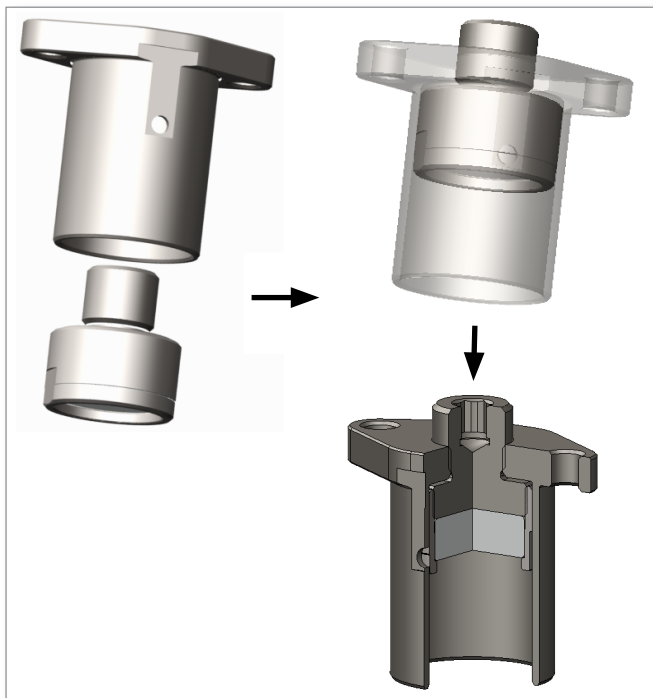
5.21.6.4 Installing a Magnetic Retainer in a Magnet Holder

1. Hold the magnet assembly in your hand.
2. Use a 5 mm (0.2 in.) hex key and assemble the magnet retainer to the magnet holder with a torque of 27 to 30 Nm (20 to 22 lbf-ft).



5.21.6.5 Placing a Magnet Holder and Magnet into a Housing

1. Install the magnet holder and magnet into the housing.
2. Use a 5 mm (0.2 in.) hex key and rotate the magnet holder in a counter-clockwise direction until the threaded part protrudes.



5.21.6.6 Assembling a Nut and a Lock Magnet Holder

1. Make sure that the thread pitch of the jam nut is 1.00 mm (0.04 in.).
2. Assemble the jam nut into the housing.
3. Adjust the height of the jam nut such that there is a 0.50 mm (0.02 in.) gap as shown in Figure 5-66.
4. Assemble the part into the synchro plate in heated condition and examine the valve pin height.
5. Adjust if required and ensure the correct valve pin height.

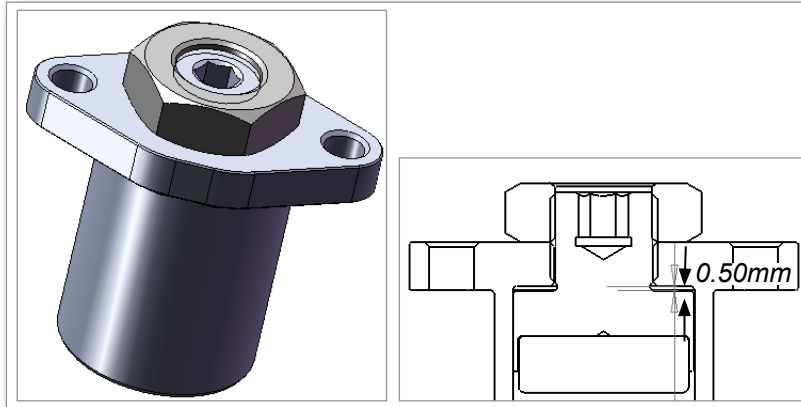
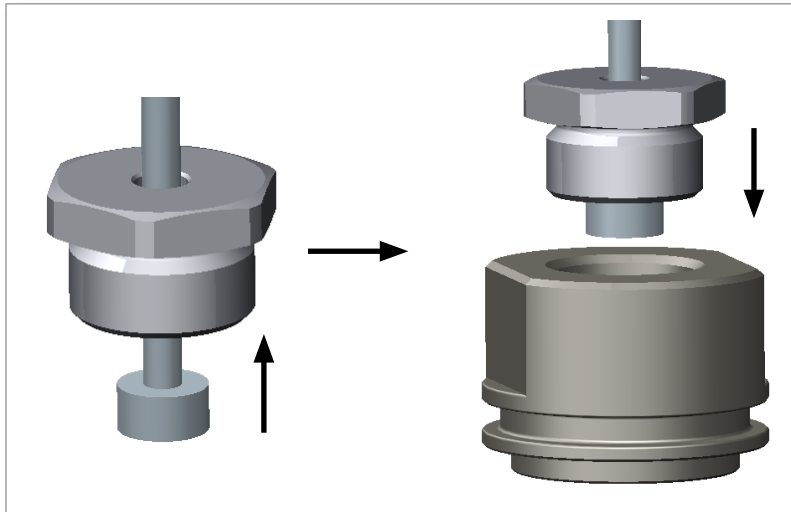


Figure 5-66 Jam nut assembly

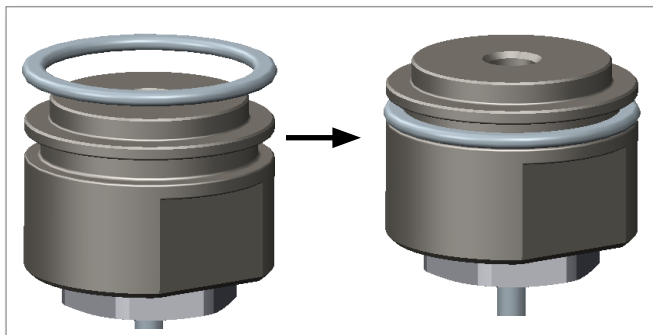
5.21.6.7 Installing a Valve Pin in a Valve Pin Holder

1. Insert the valve pin into the valve pin retainer.
2. Hold the valve pin holder with your hand.
3. Use a wrench and assemble the valve pin retainer with valve pin into the valve pin holder.



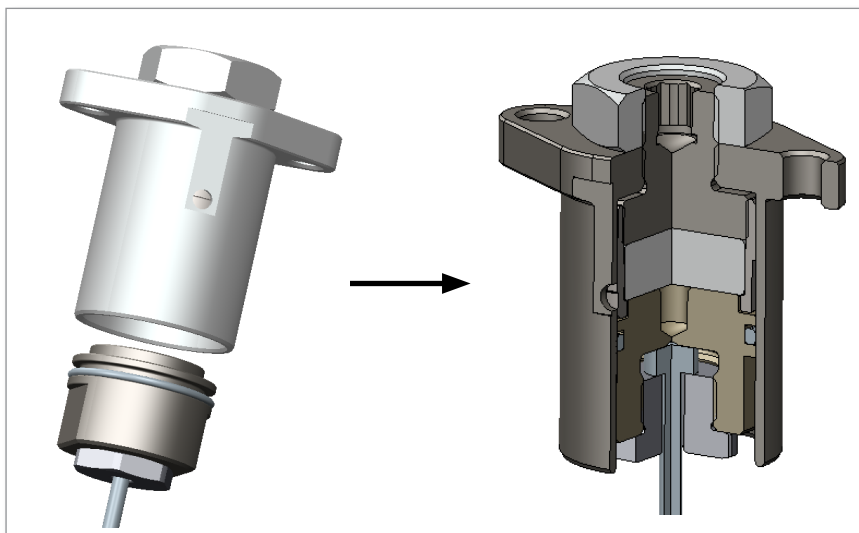
5.21.6.8 Installing an O-Ring in a Valve Pin Holder

1. Lubricate the O-ring with a thin layer of high temperature grease.
2. Install the O-ring into the correct groove on the valve pin holder.
3. Use a cloth and clean the excessive grease from the top and side faces.



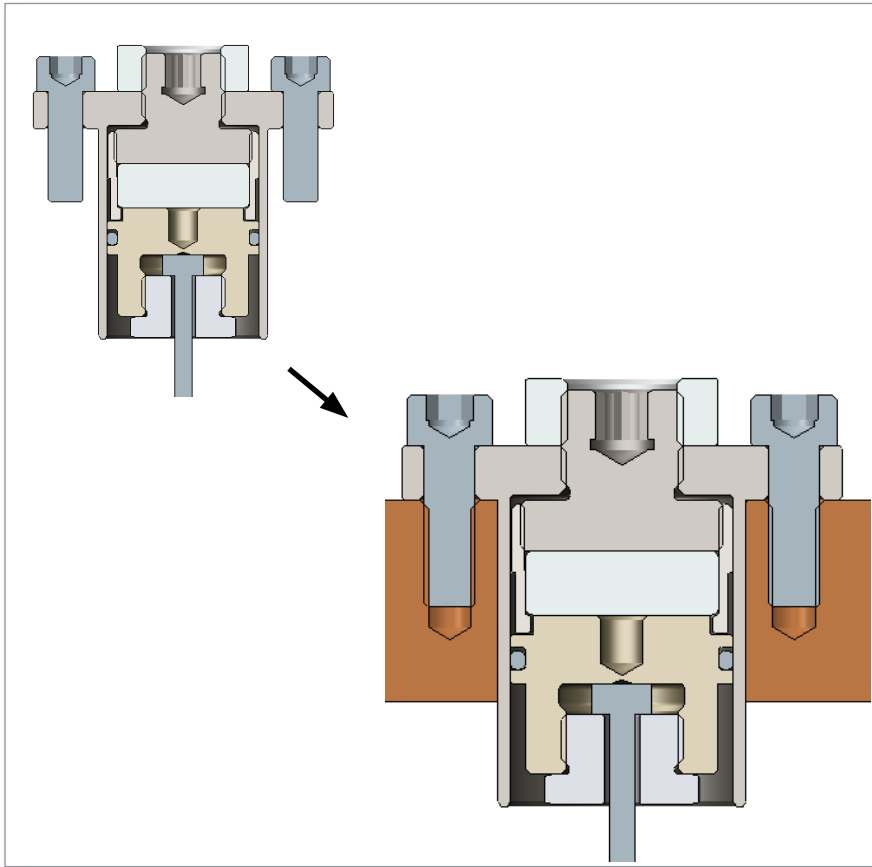
5.21.6.9 Installing a Valve Pin in a Housing Assembly

1. Carefully assemble the valve pin into the housing assembly.
2. Make sure that there are no impact forces on the magnet.



5.21.6.10 Installing a Mag-Pin Assembly in a Synchro-Plate

1. Heat the system and adjust the valve pin height if the valve pin protrusion is not correct.
2. The Mag-Pin assembly at this condition can be installed into the synchro-plate



5.22 Single Nozzle Valve System (Accu-Line)

5.22.1 Femto, Pico, Centi Accu-Line with Valve Bushing

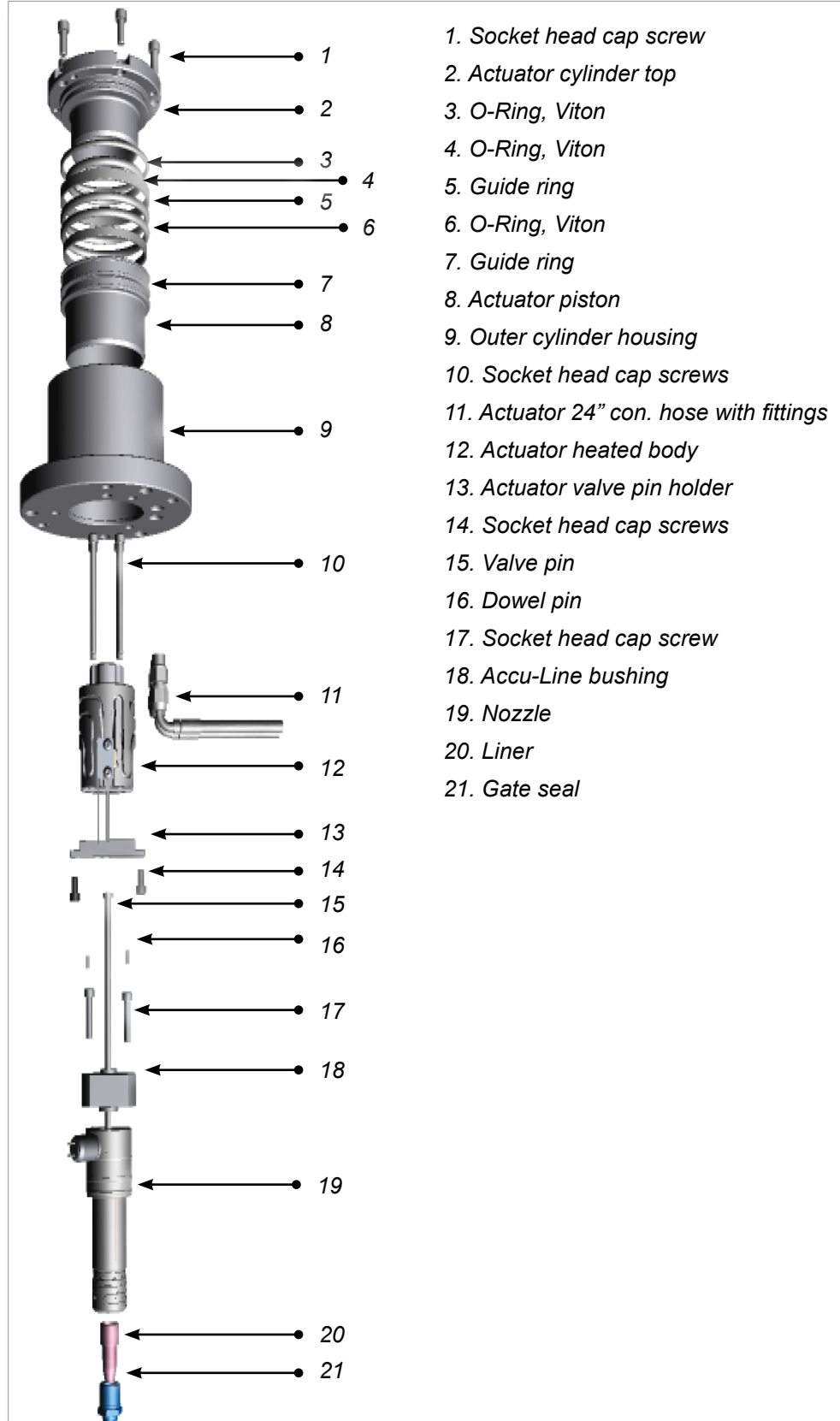


Figure 5-67 Centi Accu-Line body assembly

5.22.1.1 Pre-Assembly

The Accu-Line with valve bushing is used in Centi systems only. For Deci and Hecto applications, see 5.22.2 Deci and Hecto Accu-Line with Valve Insert on page 5-94.

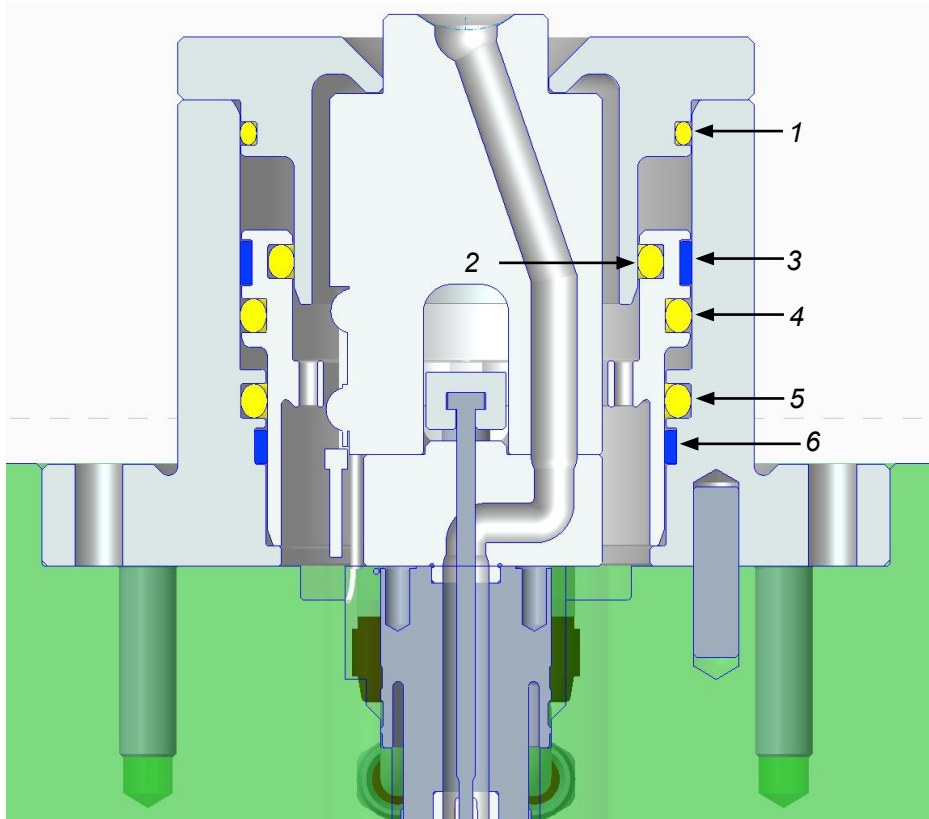
1. Cut pin to calculated length as specified in your general assembly drawing. Refer to Finishing the Tip of a Valve Pin on page 5-43.

5.22.1.2 Assembling an Accu-Line System



CAUTION

Do not use any tools to install the backup washer. Doing so may overstretch and damage the hard ring.



- | | |
|--------------------------------|-----------------------------|
| 1. Hydraulic o-ring (HYORG233) | 4. Piston seal (PS0006) |
| 2. Piston seal (PS0005) | 5. Piston seal (PS0007) |
| 3. Guide ring (GUIDERING03) | 6. Guide ring (GUIDERING04) |

1. Check components against the parts list.



2. Put cylinder backup washer and O-ring into cylinder body groove. Bend the cylinder hard ring into a kidney shape and insert into position in cylinder body.



3. Carefully push the protruding segment of the hard ring into the groove and reshape it using your finger. Make sure it seats firmly in the groove.



4. Repeat steps 1 through 3 to install the inner seal into the piston.



5. Use your hand and install piston backup washer and O-ring into the designated outer groove.

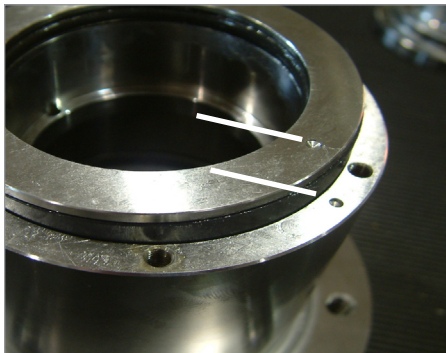
6. Place the back up washer on the shorter side of the piston.
7. Place one side of piston hard ring into position and carefully push it into the groove using your fingers. Apply a small amount of lubrication to O-ring and the inner side of the hard ring to help assembly.



8. Apply a small amount of lubrication to all outside faces of seals prior to step 8 to help assembly.
9. Insert the piston (with seals and guide ring) into the cylinder body (with seal and guide ring).



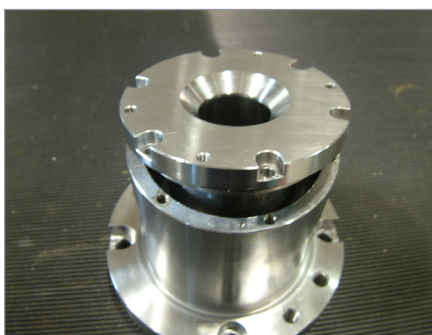
10. Ensure that timing marks on both components are aligned.



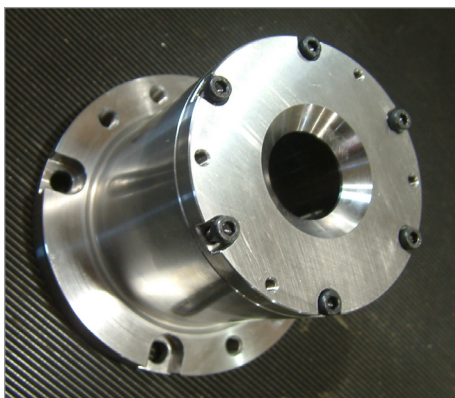
11. Make sure installed seals engage into guiding chamfer. Press piston smoothly and gently, applying even force.



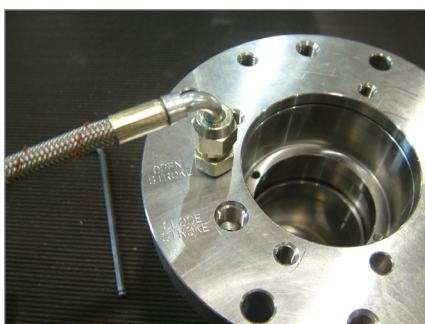
12. Insert O-ring into cylinder top and assemble it to cylinder body.



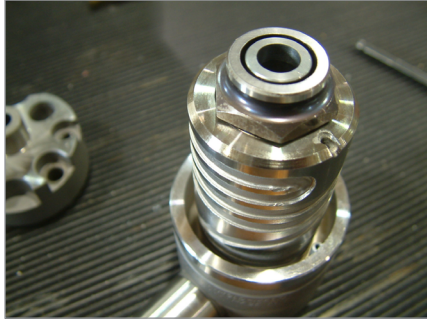
13. Tighten fasteners to specifications detailed in general assembly drawings.



14. Turn assembled unit over and attach actuator connection hose fittings to the supply ports. Tighten to specifications detailed in your general assembly drawing.



15. Attach gate seal and liner to nozzle. Tighten to specifications detailed in your general assembly drawings. Attach nozzle thermocouple.



16. Attach valve bushing. Tighten to specifications detailed in your general assembly drawing.



17. Slide the valve pin into the nozzle assembly.

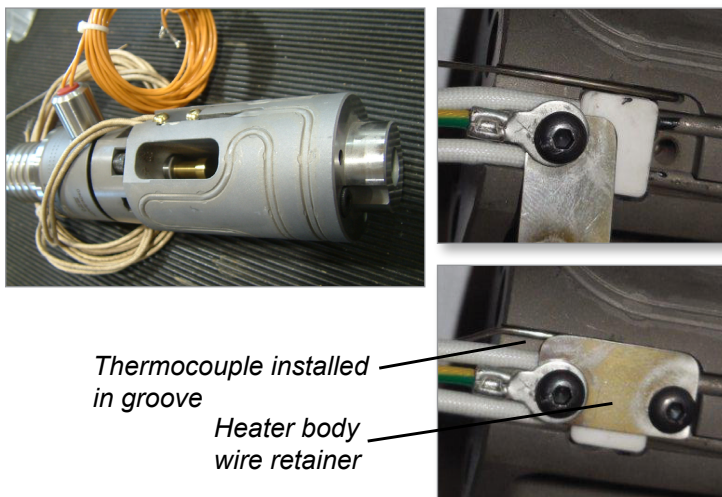


18. Place the heater body over the assembly.

19. Install the heater body thermocouple as follows:

- a) Remove the body wire retainer.
- b) Fully insert the end of the thermocouple into the mating hole and bend it into the thermocouple groove.
- c) Reinstall the wire retainer.

20. Finish installing the heater body onto the nozzle assembly and torque to the specification given in your general assembly drawing.



21. Slide the valve pin holder into the heater body slot and over the valve pin head.

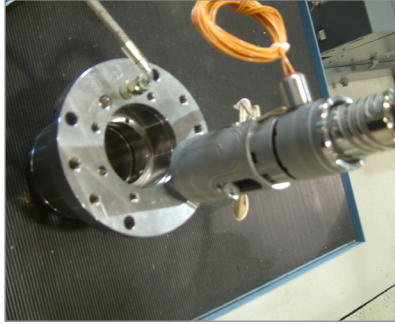


22. The valve pin holder should be locked with and move together with the valve pin. See Figure 5-68.

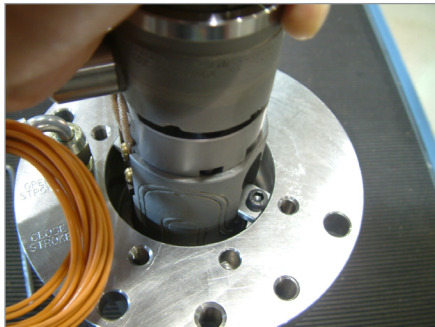


Figure 5-68 Accu-Line valve pin holder and valve pin

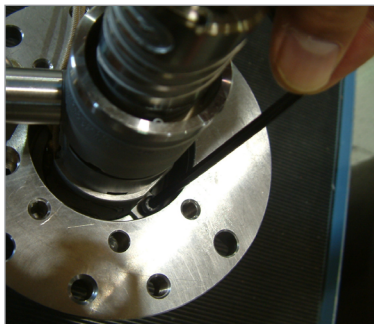
23. Carefully place the nozzle assembly into the hydraulic unit as shown.



24. Ensure that the nozzle terminal end is correctly oriented.



25. Secure the valve pin holder to piston. Tighten to specifications detailed in your general assembly drawing.



26. Assemble inside mold and verify assembly and all connections for accuracy.



5.22.2 Deci and Hecto Accu-Line with Valve Insert

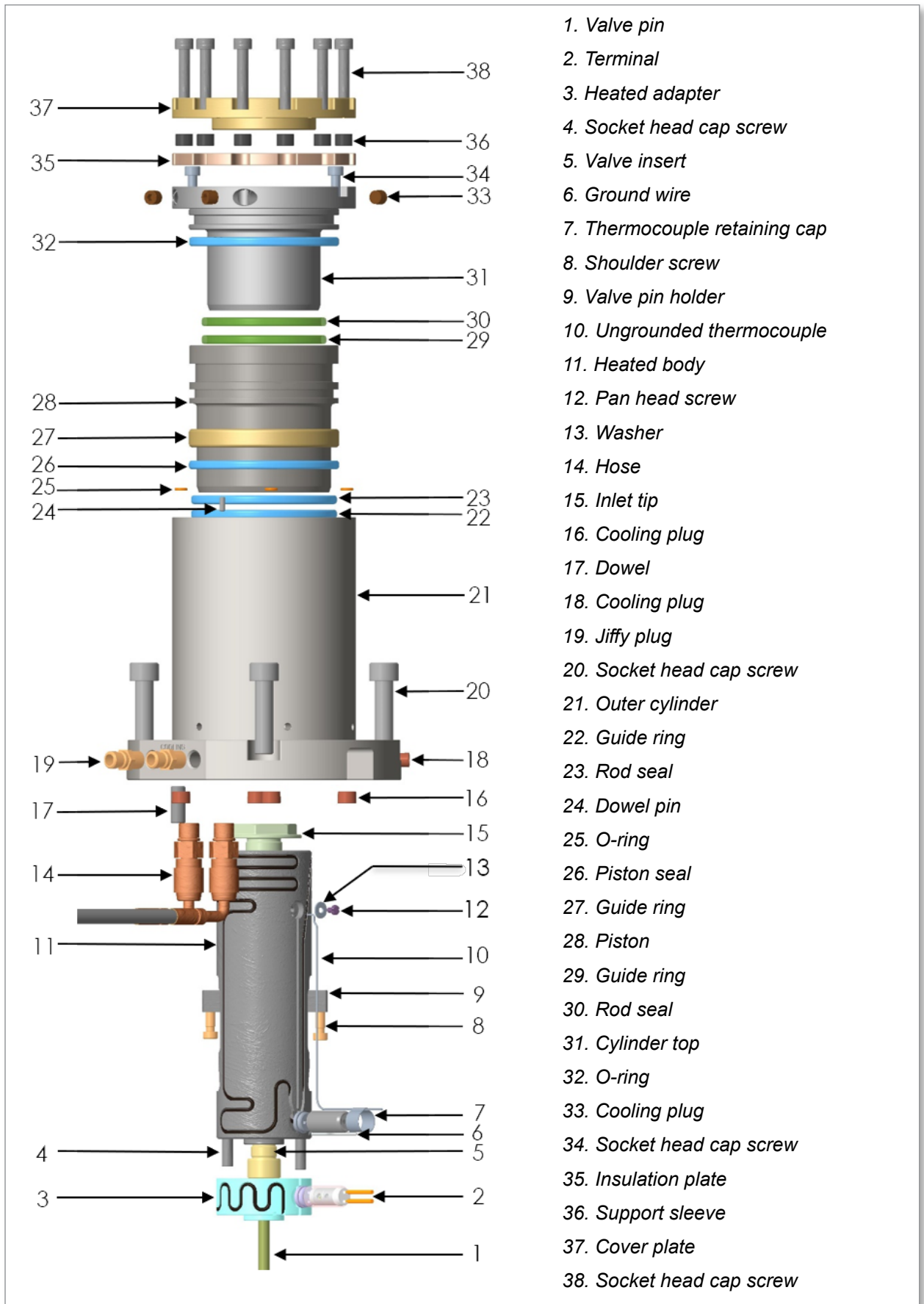
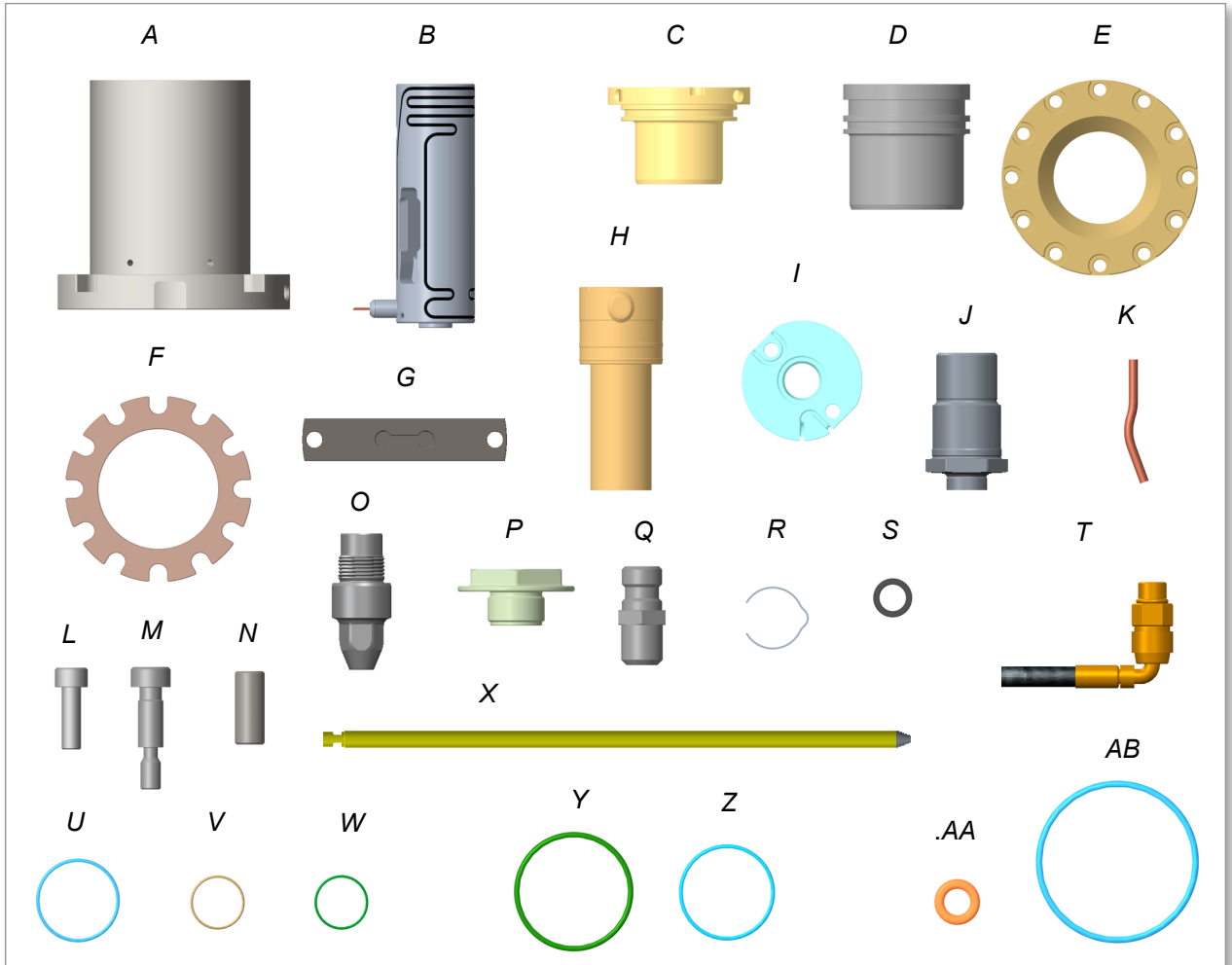


Figure 5-69 Deci and Hecto Accu-Line body assembly

5.22.2.1 Pre-Assembly

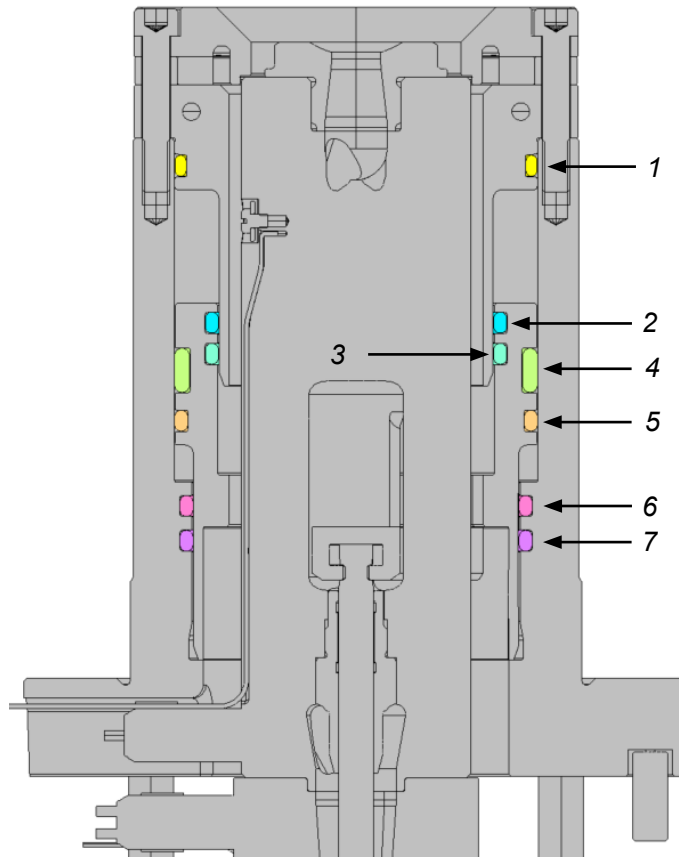
The Accu-Line with valve insert is used in Deci and Hecto systems only. For Centi applications, see 5.22.1 Femto, Pico, Centi Accu-Line with Valve Bushing on page 5-86.

1. Make sure that the length of your valve pin is the same as that of your general assembly drawing.
2. Make sure that your components match those of the parts list:



- | | |
|--------------------------|---------------------|
| A. Outer cylinder | O. Valve insert |
| B. Heated body | P. Inlet tip |
| C. Cylinder top | Q. Jiffy plug |
| D. Piston | R. TC retaining cap |
| E. Cover plate | S. Support sleeve |
| F. Insulation plate | T. Hose |
| G. Valve pin holder | U. Guide ring |
| H. Nozzle | V. Guide ring |
| I. Adapter | W. Guide ring |
| J. Gate seal | X. Valve pin |
| K. Ground wire | Y. Rod seal |
| L. Socket head cap screw | Z. Rod seal |
| M. Shoulder screw | AA.O-ring* |
| N. Dowel pin | AB.O-ring* |

*O-ring kit ORIA18KIT consists of these parts.

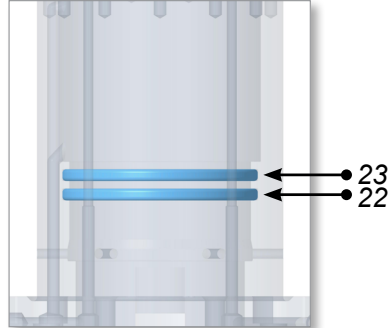
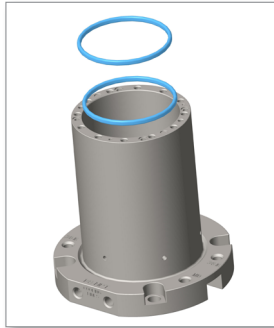


- | | |
|-----------------------------|-----------------------------|
| 1. O-Ring (ORNG0044) | 5. Piston seal (PS0026) |
| 2. Rod seal (RODSEAL19) | 6. Rod seal (RODSEAL20) |
| 3. Guide ring (GUIDERING15) | 7. Guide ring (GUIDERING16) |
| 4. Guide ring (GUIDERING17) | |

5.22.2.2 Assembling an Accu-Line System

Before doing the following procedure, check the stroke height stated on your general assembly drawing.

1. Apply grease to the rod seal and guide ring grooves in the inner surface of the cylinder.
2. Use your fingers to gently push the rod seal and guide ring into the grooves in the cylinder. Make sure that both sit firmly in the grooves.



22. Guide ring

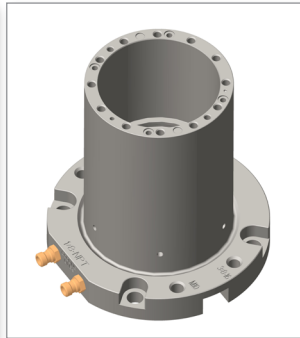
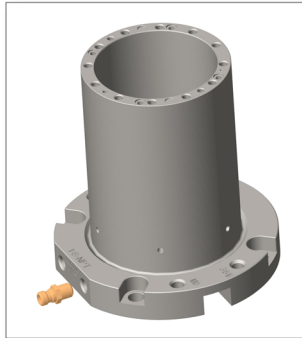
23. Rod seal



CAUTION

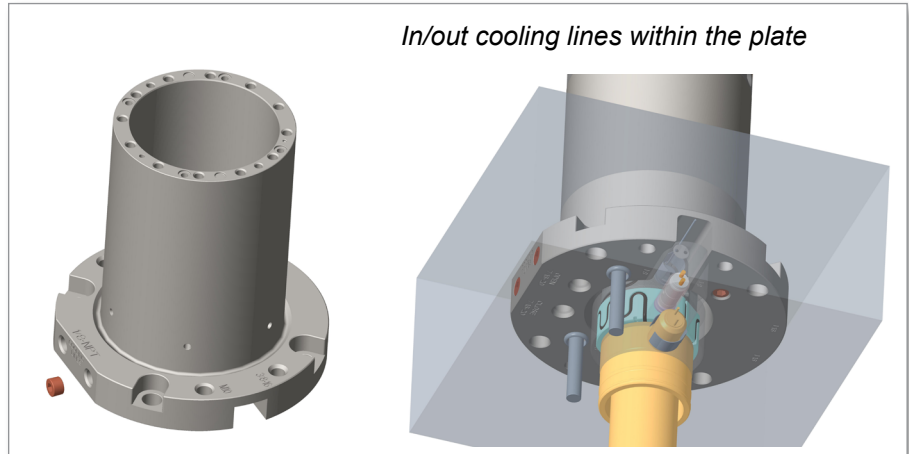
The mold temperature must be greater than 80°C to use chillers.

3. Insert the jiffy plugs (for the cooling connection) into the supply ports of the cylinder.

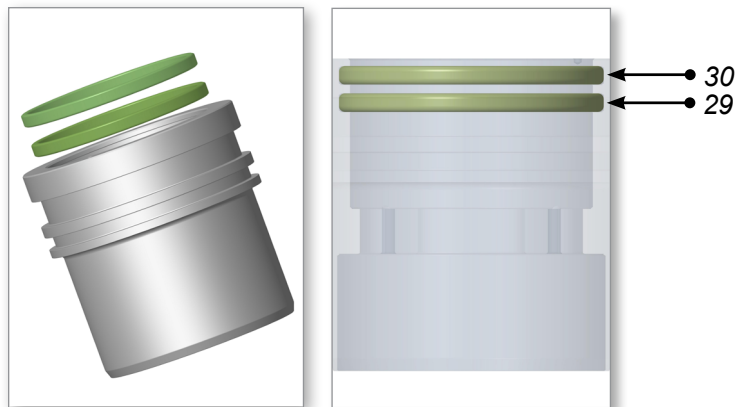


4. Do the following step when there are cooling lines within the plates. Use the bottom ports for the cooling connections as shown in your general assembly drawing.

5. Insert the plugs into the supply ports of the cylinder, and seal the lines.

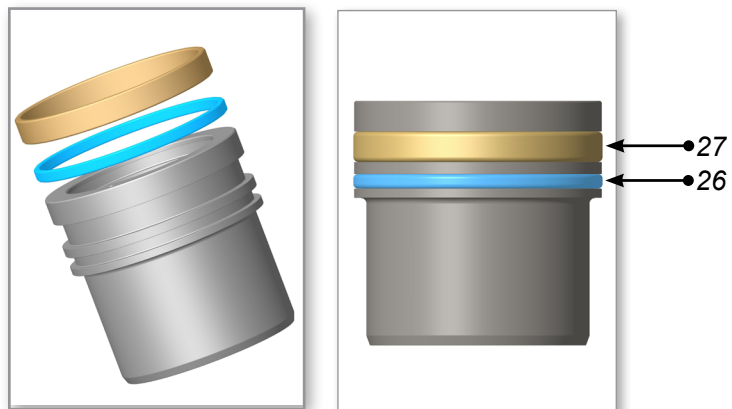


6. Apply grease to the guide ring, piston seal, and rod seal assembly grooves in the outer surface of the piston.
7. Use your fingers to gently push the rod seal, guide ring, and piston seal into the grooves in the piston. Make sure that they sit firmly in the grooves.



29. Guide ring

30. Rod seal



26. Piston seal

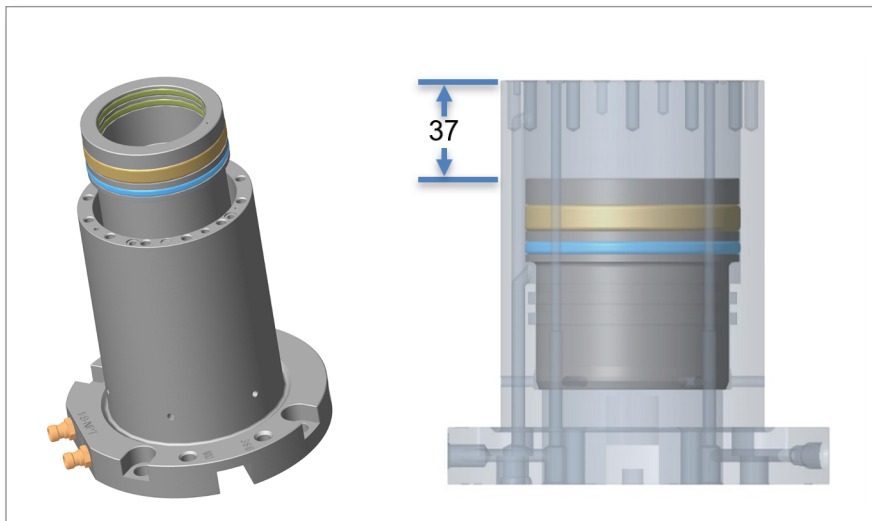
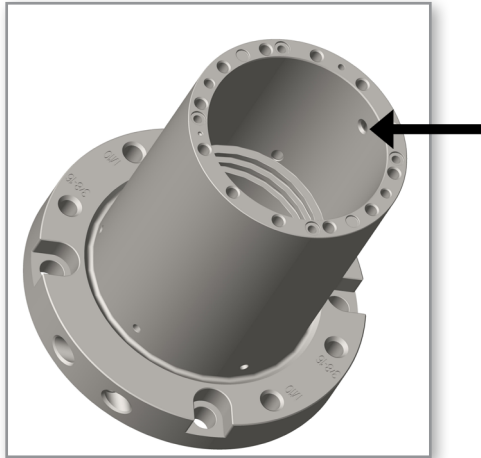
27. Guide ring

- Use both hands, apply even force, and gently insert the piston into the outer cylinder until it sits evenly. Make sure that there is 37 mm between the top surfaces of the piston and the cylinder.

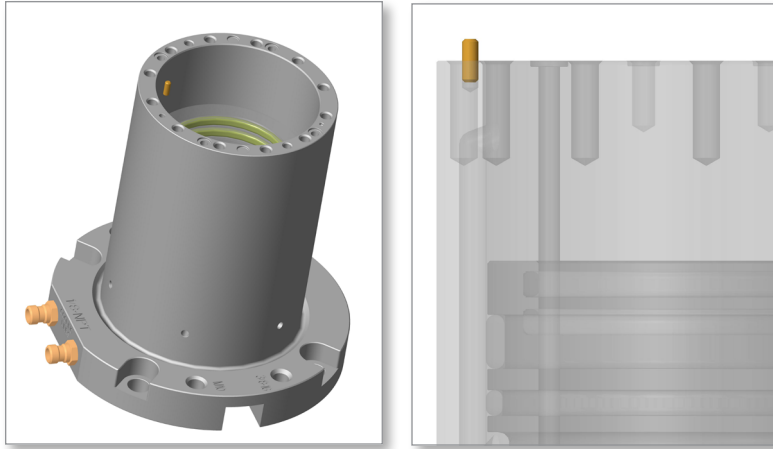


CAUTION

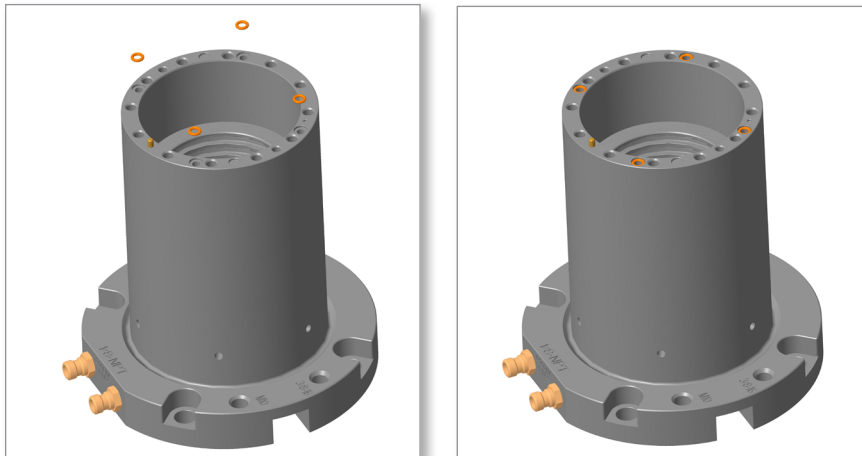
The hole shown in the following figure has a chamfer. Be careful to avoid damaging the piston seal when inserting the piston assembly.



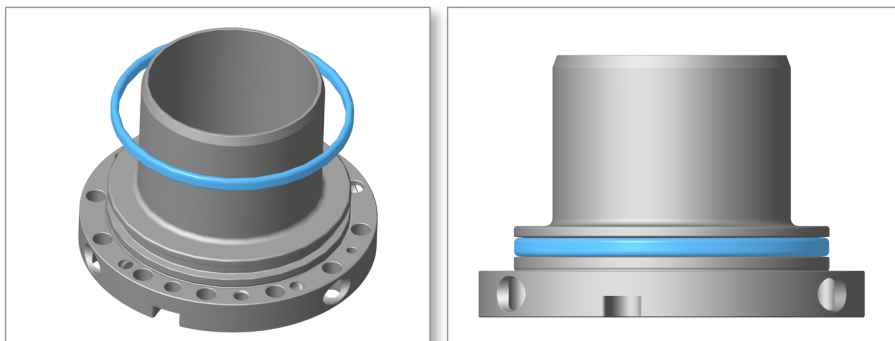
9. Insert the dowel pin into the outer cylinder assembly.



10. Use your fingers to gently push the O-rings into the outer grooves in the cylinder. Make sure that the O-rings sit firmly in the grooves.

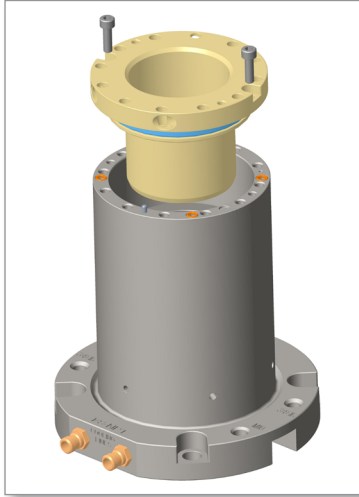


11. Apply grease to the O-ring assembly groove in the outer surface of the cylinder top.
12. Use your fingers to gently push the O-ring into the outer groove of the cylinder top. Make sure that the O-ring sits firmly in the groove.

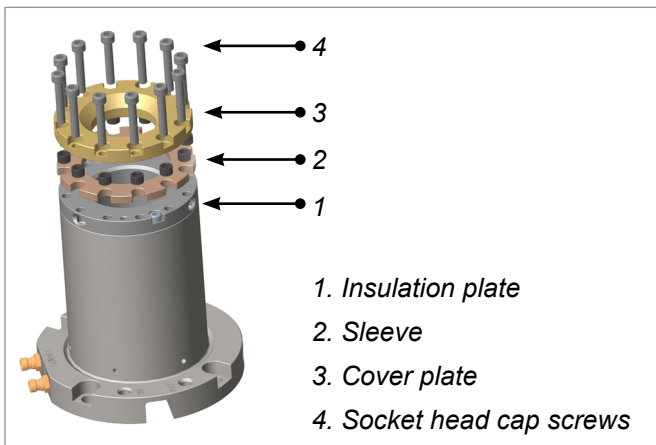


13. Install the cylinder top into the outer cylinder, making sure that the O-rings are not disturbed from their positions. Align it with the anti-rotation dowel.

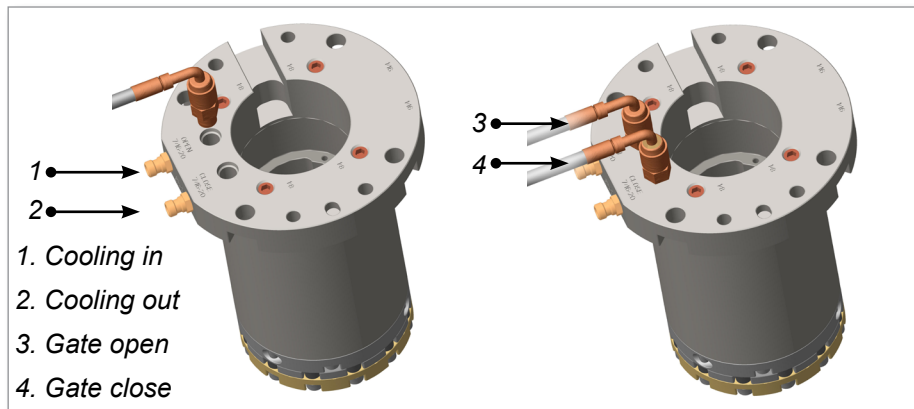
14. Insert the screws and torque them to 7 N·m (5 lbf-ft).



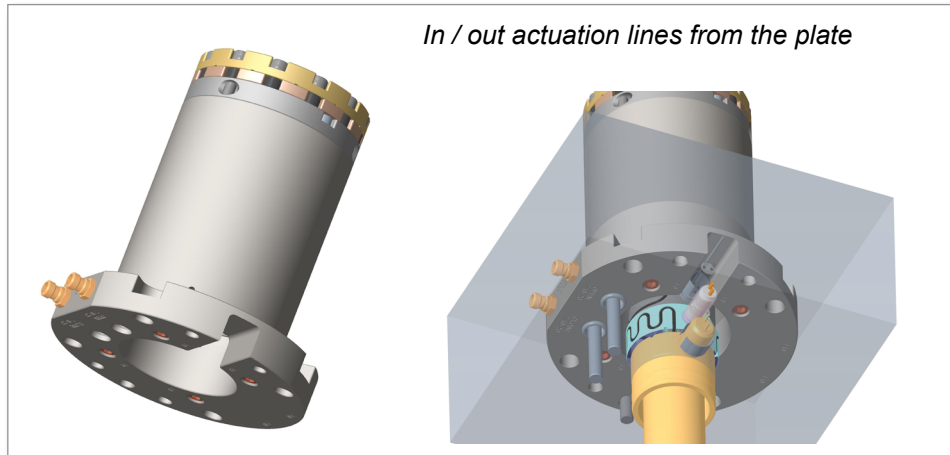
15. Place the insulation plate on the cylinder body, and install the support sleeves. Place the cover plate on the insulation plate. Insert the socket-head cap screws and tighten them to a torque of 14 N·m (10 lbf-ft).



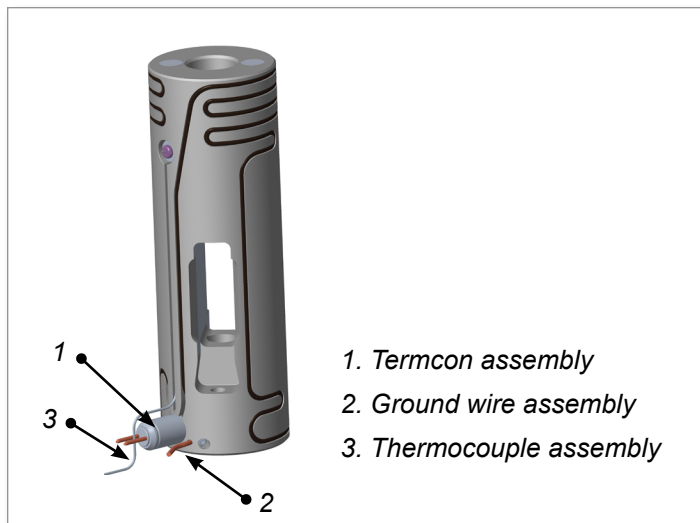
16. Insert the actuator connection hose fittings into the supply ports on the bottom of the unit assembly.



17. Optional (must be done when there are actuation connections within the plates): Install the actuation connections into the bottom supply ports of the cylinder. Pressure test the cooling connection. Make sure that there are no leaks.



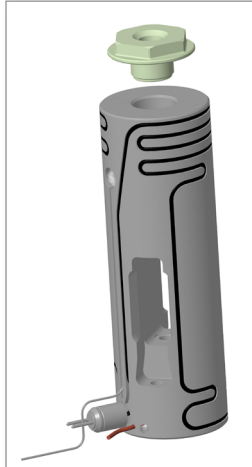
18. Install the termcon assembly, ground wire assembly, and thermocouple assembly in the heated body. Insert the end of the thermocouple fully into the mating hole and bend it into the thermocouple groove.



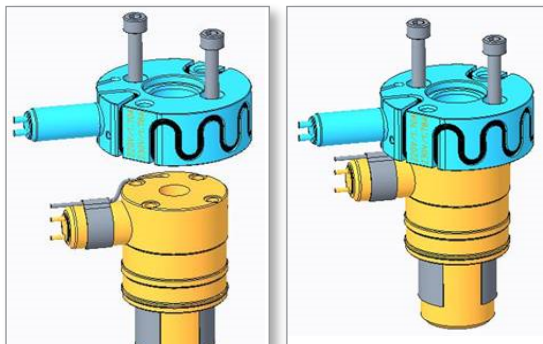
19. Use a box spanner to install the valve insert in the heater body, and tighten to a torque of 68 N·m (50 lbf-ft).



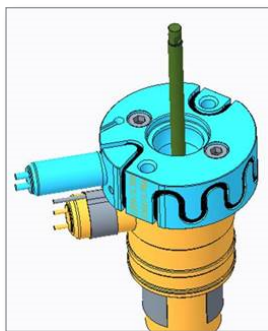
20. Install the inlet tip in the heated body, and tighten to a torque of 61 N·m (45 lbf-ft).



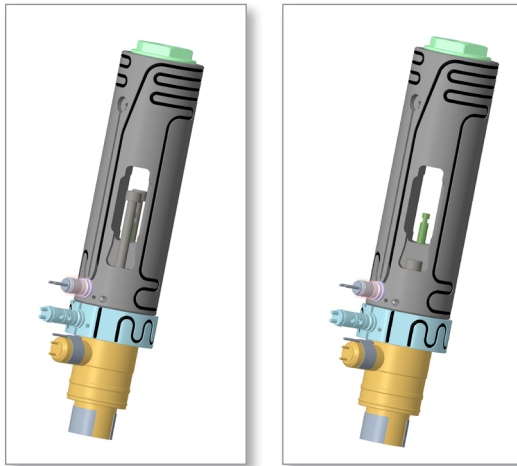
21. Attach the gate seal and liner to the nozzle.
 22. Attach the nozzle thermocouple.
 23. Install the adapter on the nozzle.
 Optional (do not do for Hecto nozzles; two screws will be installed in the heated body):
 Insert the screws, and tighten them to a torque of 7 N·m (5 lbf-ft).



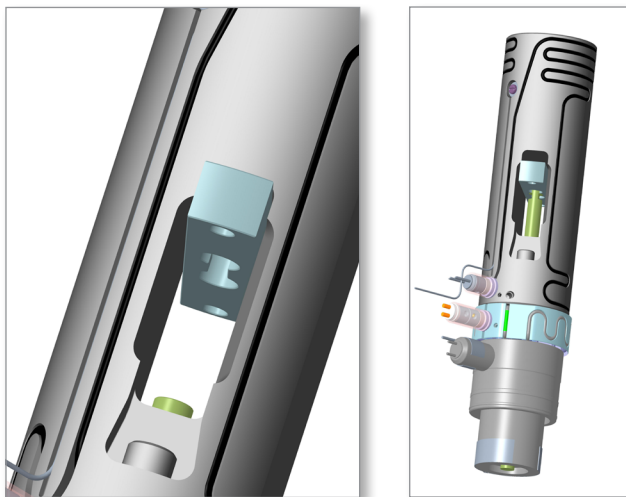
24. Slide the valve pin into the nozzle assembly.



25. Install the heated body onto the nozzle assembly.
Insert the screws, and tighten them to a torque of 14 N·m (10 lbf·ft).



26. Slide the valve pin holder into the heated body slot and over the valve pin head.
Insert the valve pin head into the keyhole slot in the valve pin holder.
Slide the holder so that the pin head is located in the narrow portion of the slot.

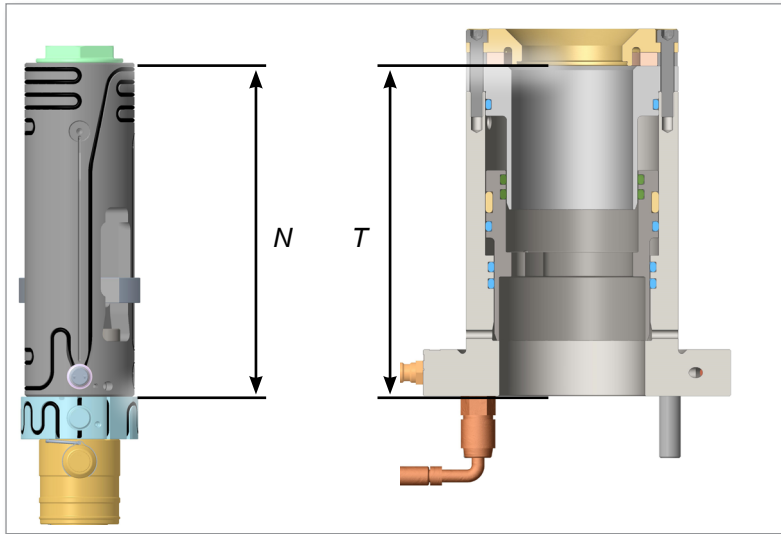


27. In the cold condition, measure the dimension N of the heated body and the dimension T of the cylinder body. Make sure that they are the same.

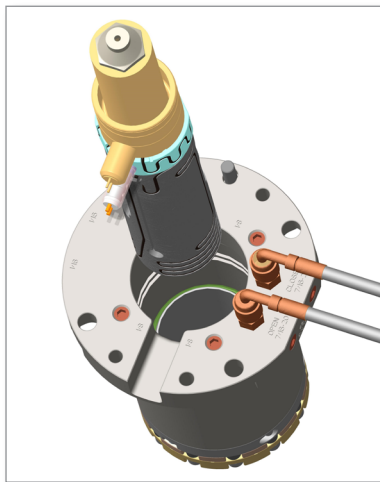


NOTE

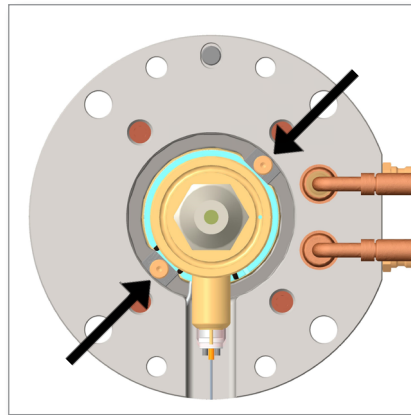
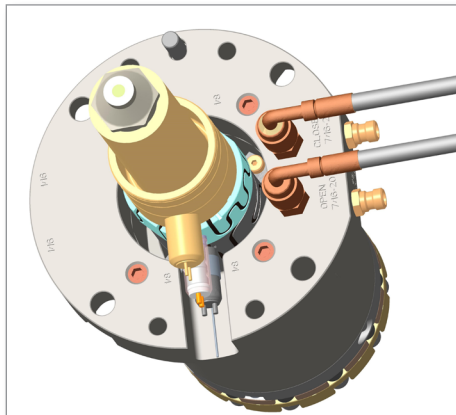
The air gap is determined by the flange depth of the mold plate.



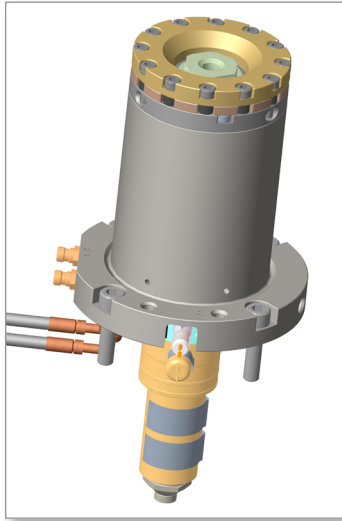
28. Carefully place the nozzle assembly into the hydraulic unit. Make sure that the nozzle terminal end is correctly oriented.



29. Attach the valve pin holder to the piston using shoulder head screws, and tighten them to a torque of 3 N·m (2.2 lbf-ft).



30. Install the unit in the mold.
Examine all the connections and actuations.



5.23 TIT Edge-Gated System



WARNING - READ MANUAL

Read Section 3 - Safety on page 3-1 before assembling, installing or removing any non-standard components.

The following section contains procedures on non-standard components.

Edge gated systems are supplied with gate seals that are oversized. They must be ground prior to installing the nozzle into the nozzle well bore (minus heat expansion).

The exception is gate seals supplied without the gate. The gate must be placed into gate seal after the seal is ground to the final dimension. Refer to the gate detail on your general assembly drawing.

Heat expansion of the nozzle must also be considered.

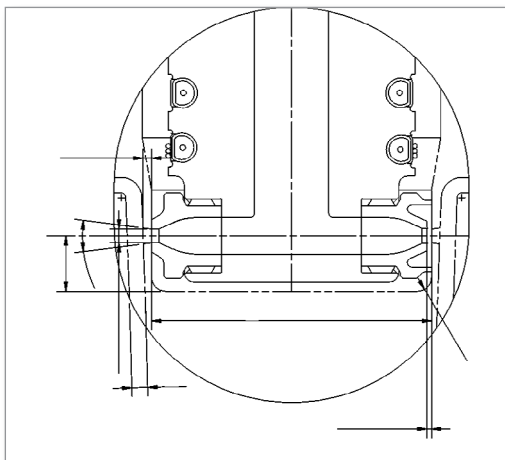


Figure 5-70 TIT Edge gated system

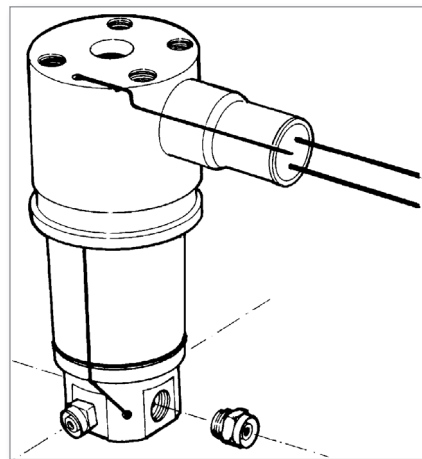


Figure 5-71 TIT Edge gate seal

5.23.1 Removing TIT Edge Gate Seals

The following procedure applies to TIT Edge nozzles only. The gate seals have an M6 thread.



NOTE

If the cavity plate can be easily removed, you can access the nozzle seals while still in the system.



CAUTION

Hot Runner systems must be cold before the cavity plate can be removed. Failure to obey may cause damage to parts.

1. Apply penetrating oil to the threads.
2. Heat the nozzle to processing temperature to melt any residual plastic that may be in the gate seal area.
3. When the nozzle approaches set temperature, use Mold-Masters supplied socket to remove the seal.



CAUTION

Cylindrically ground gate seals cannot be re-installed. Failure to obey may cause damage to parts.

5.24 Melt-Disk System



WARNING - READ MANUAL

Read Section 3 - Safety on page 3-1 before integrating, operating or doing maintenance procedures on the Melt-Disk system.

5.24.1 Identifying a Reverse Melt-Link

Some Melt-Disk systems are fitted with a Reverse Melt Link. To determine whether your system contains a Reverse Melt Link, check the plate which is located on the side of the Hot Half. See Figure 5-72.

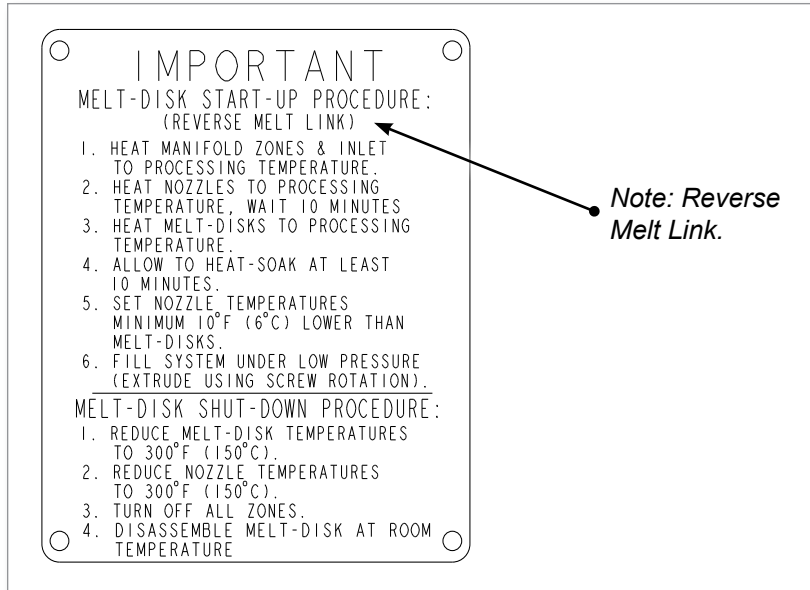


Figure 5-72 Reverse Melt Link plate

You can also check your parts list on your general assembly drawing for the Reverse Melt Link part numbers:

- MTL014A (female in nozzle)
- MTL014B (male in Melt-Disk)

If your system has a Reverse Melt Link, you will need to follow the Reverse Melt Link startup and shutdown procedures. See Sections 8.2.3.2 and 8.3.3.2 for more information.

5.24.2 Example

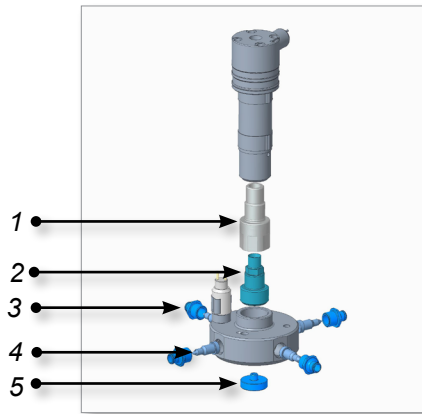


Figure 5-73 Melt-Disk system with brazed/paste heater element

1. Melt transfer link on nozzle
2. Melt transfer link on Melt-Disk
3. Transfer seal
4. Torpedo tip
5. Melt-Disk locator

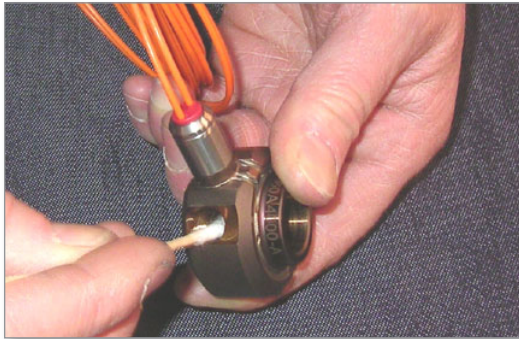
5.24.3 Preparing and Cleaning



CAUTION
Tighten the gate seals at processing temperature. Failure to do so may result in leaks.

All nozzles, manifolds and components must be free of the rust inhibitor applied at the factory.

1. Disassemble the Melt-Disk assembly.
2. Wipe down the Melt-Disk.
3. Remove the part and wipe clean. If necessary, use a cotton swab to clean narrow interior surfaces or screw threads. For larger surfaces, such as mold plates use thinner in spray form to clean channels and recesses.



4. Apply anti-seize compound to the threads of the gate seals, using Mold-Masters supplied compound.



5. Insert the pointed end of the tips (torpedoes) into the threaded end of the gate seal.



6. Thread the gate seal assembly into the Melt-Disk. Secure the Melt-Disk in a soft vice

and torque gate seals in the cold condition to value specified below or in your general assembly drawing. Do not over tighten the vice. Ensure none of the components are damaged.

Thread size	Imperial	Metric
M9	10 - 11 ft-lb	14 - 15 Nm

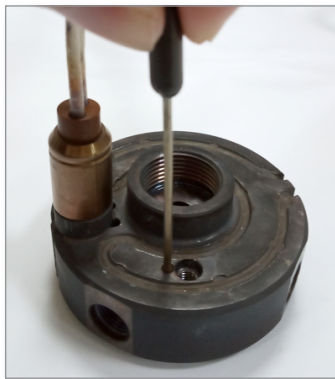
7. Tighten gate seals in heated condition at processing temperature as specified in your general assembly drawing.

5.24.4 Assembling a Melt-Disk Thermocouple

1. Remove the thermocouple retaining screw from the Melt-Disk.



2. Insert the thermocouple tip into the thermocouple hole until it touches the bottom of the hole.



3. Bend the thermocouple 90° towards the terminal.



4. Attach the thermocouple with the thermocouple retaining screw.



5. Use heat resistant tape just above the insulator pod to attach the nozzle wires and thermocouple wires together.



6. Set the thermocouple assembly aside.



5.24.5 Installing a Melt Disk in a Nozzle

5.24.5.1 Reverse Two-Piece Melt-Link

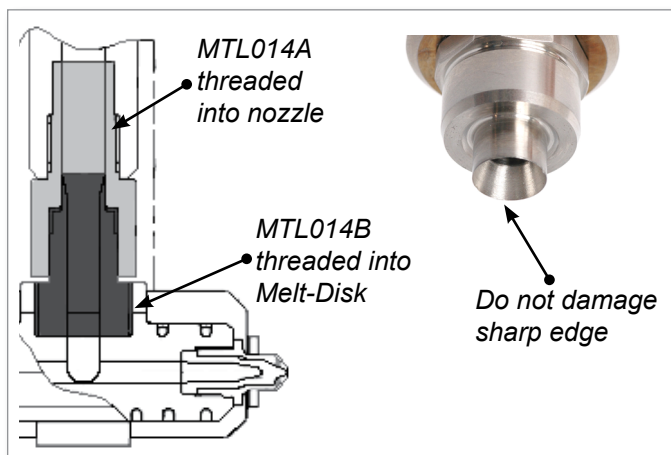
1. Apply anti-seize compound to the threads of the Melt-Link using Mold-Masters supplied compound.



2. Thread Melt-Link MTL14A into the nozzle and Melt-Link MTL14B into the Melt-Disk.



3. Tighten COLD to 27-30 Nm (20-22 ft-lb).
4. Assemble Melt-Disks onto the nozzles according to mold design via the Melt-Link.
5. Ensure the sharp edge of the Melt-Link does not get damaged when pushing the two halves together.



5.24.5.2 One-Piece Melt-Link

1. Apply anti-seize compound to the threads of the 1-piece Melt-Link, using Mold-Masters supplied compound.



2. Thread the Melt-Link into the nozzle.



3. Tighten the Melt-Link COLD to the value specified in your general assembly drawing.
4. Assemble Melt-Disks onto the nozzles according to mold design.
5. Ensure the sharp edge of the Melt-Link does not get damaged.



5.24.6 Optional Quick Disconnect Terminal Ends

Optional quick disconnect terminal end kits are available on request. The kit consists of:

- QDISC-CRIMP Tool
- TERMCON09 (Power)
- TERMCON10 (Thermocouple)

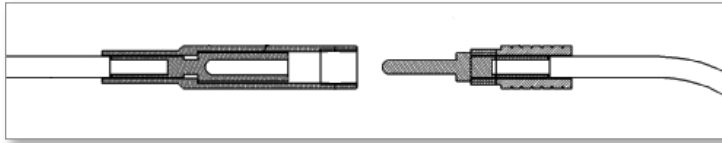


Figure 5-74 Power quick disconnect terminal ends

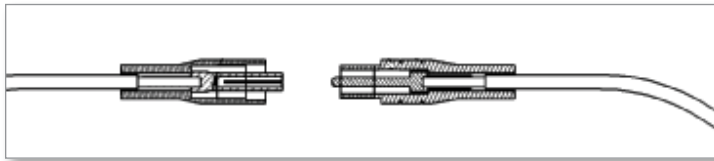


Figure 5-75 Thermocouple quick disconnect terminal ends

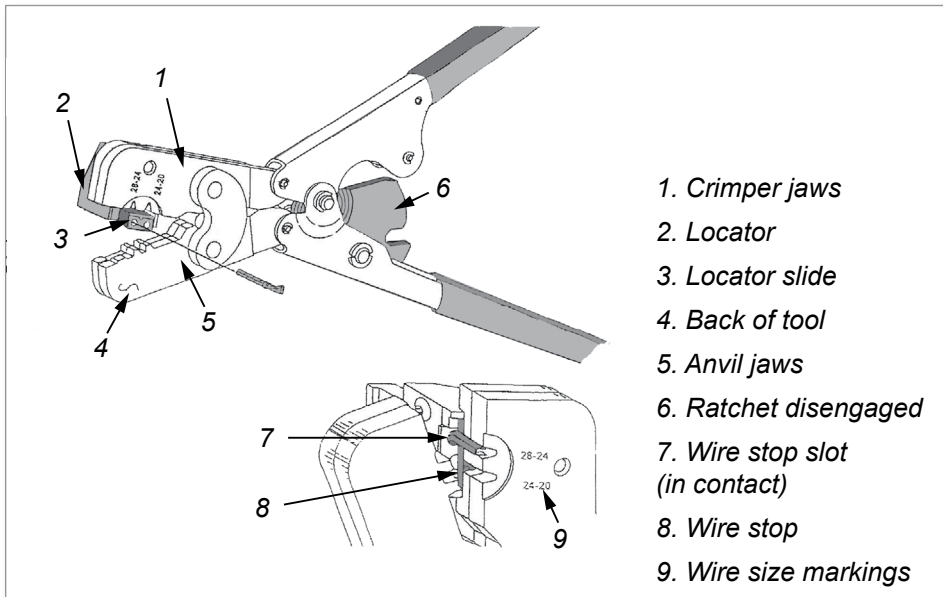


Figure 5-76 QDISC - CRIMP tool

5.24.6.1 Crimping the Quick Disconnects

**CAUTION**

Do not attempt to close the tool handles when a locator slide is positioned between the crimping jaws. Damage to the tool jaws and/or locator slide may result.

Select the appropriate loose-piece contact and identify the crimp cavity according to the wire size markings on the tool.

1. Hold tool so wire side is facing you. Make sure ratchet is released. Squeeze tool handles together and allow them to open fully.
2. Grasp locator and simultaneously move locator toward anvil jaws and push locator slide into crimper jaws. Spring tension will hold locator position against crimper jaws.
3. Insert contact mating end into appropriate hole in locator slide. Orient contact so wire barrel and insulation barrel are facing crimper jaws (wire size markings).
4. Pull locator slide out of crimping jaws. Spring tension will pull locator down and allow wire stop to enter the slot between barrel and contact shoulder.
5. Make sure both sides of the insulation barrel are started evenly into the crimper jaws. Do not attempt to crimp an improperly positioned contact.
6. Squeeze tool handles together until ratchet engages. Do not deform insulation barrel or wire barrel.
7. Insert properly stripped wire contact into the wire barrel until wire butts against the wire stop.
8. Holding wire in place, squeeze tool handles together until ratchet releases. Allow tool handles to open fully. Move locator toward anvil jaws and remove crimped contact.

5.25 Melt-Cube Systems



WARNING - READ MANUAL

Read Section 3 - Safety on page 3-1 before integrating, operating or doing maintenance procedures on a Melt-Cube system.



CAUTION

Determine the type of Melt-Cube in your system before assembling, installing or doing maintenance on your Melt-Cube. The assembly and installation instructions are different for each design. Ensure that the correct instructions are followed for your design of Melt-Cube. Failure to do the correct instructions will damage the parts.

Mold-Masters has different Melt-Cube designs. See 5.25.1 Identifying Your Melt-Cube Design for more information. If in doubt, contact your Mold-Masters representative for assistance.

For Melt-Cube design A, see 5.25.5 Melt-Cube Design A on page 5-121.

For Melt-Cube design B, see 5.25.6 Melt-Cube Design B on page 5-136.

5.25.1 Identifying Your Melt-Cube Design

Melt-Cube design A and Melt-Cube design B are not interchangeable.

5.25.2 Melt-Cube Design A (Angled version)

Melt-Cube design A uses five screws. See Figure 5-77.

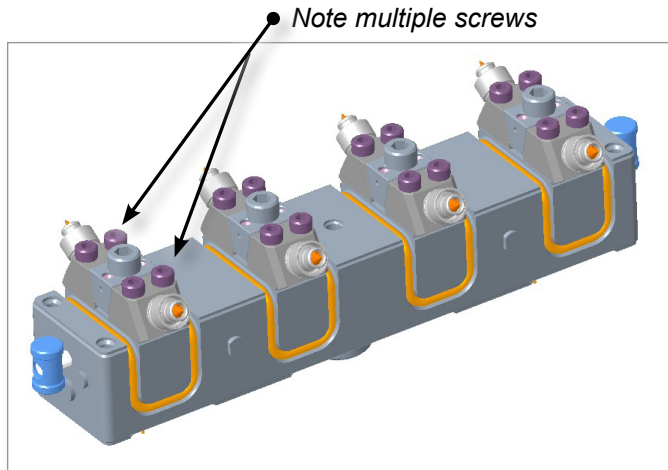


Figure 5-77 Melt-Cube design A

5.25.3 Melt-Cube Design B (Horizontal version)

Melt-Cube design B uses a single screw. See Figure 5-78.

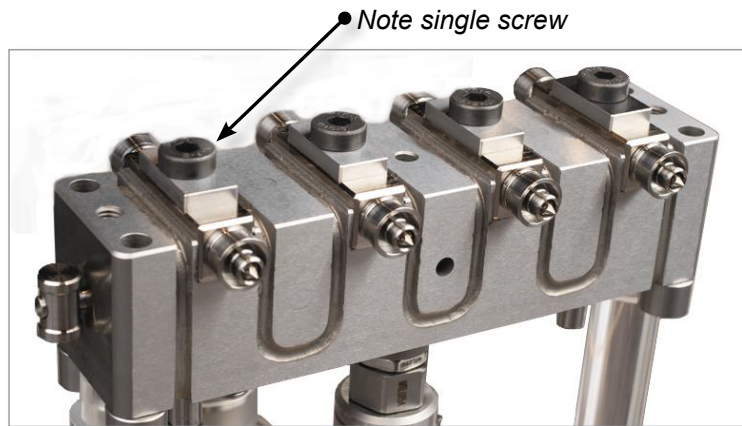


Figure 5-78 Melt-Cube design B

5.25.4 Example

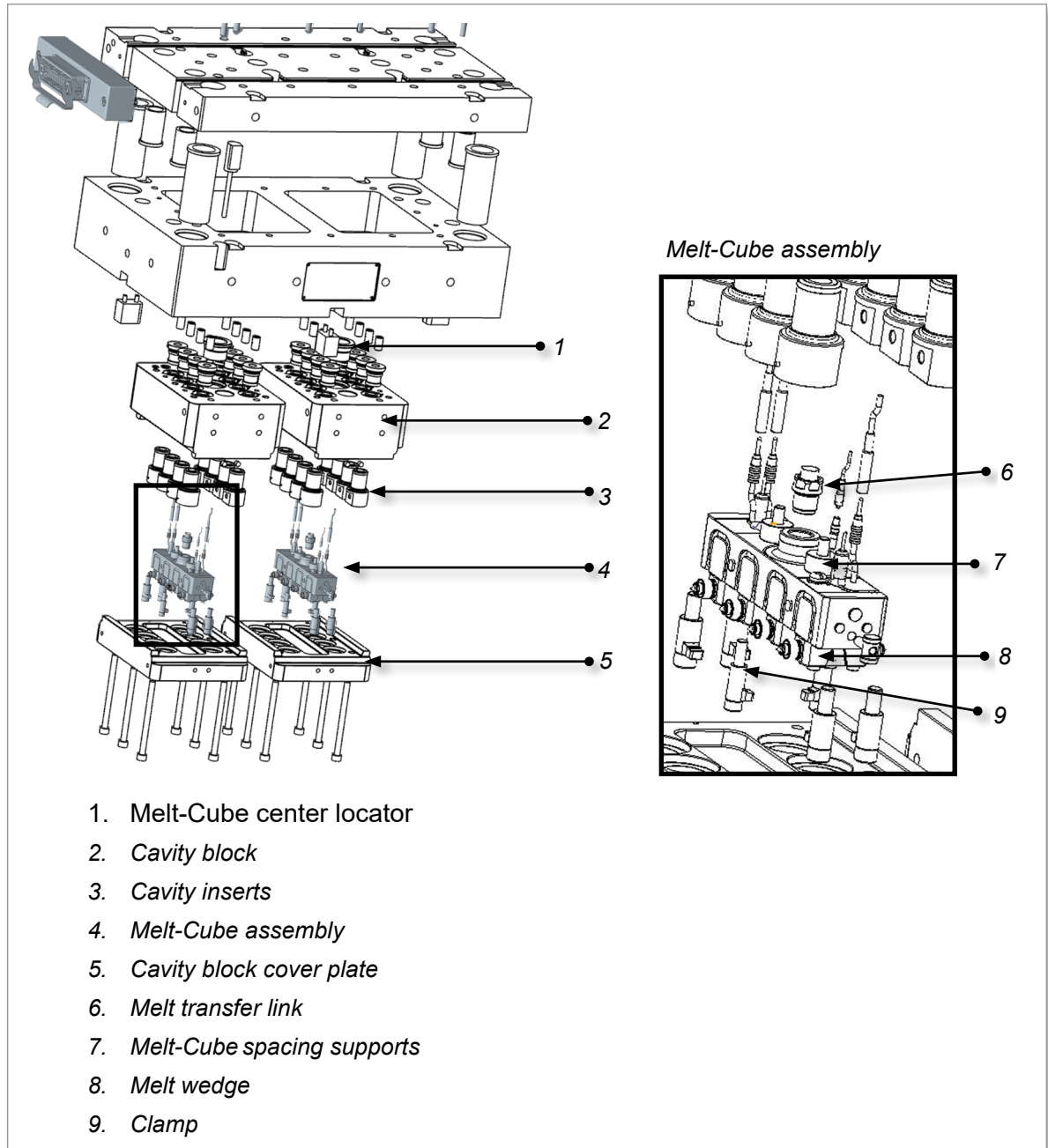


Figure 5-79 Example of a Melt-Cube system

5.25.5 Melt-Cube Design A

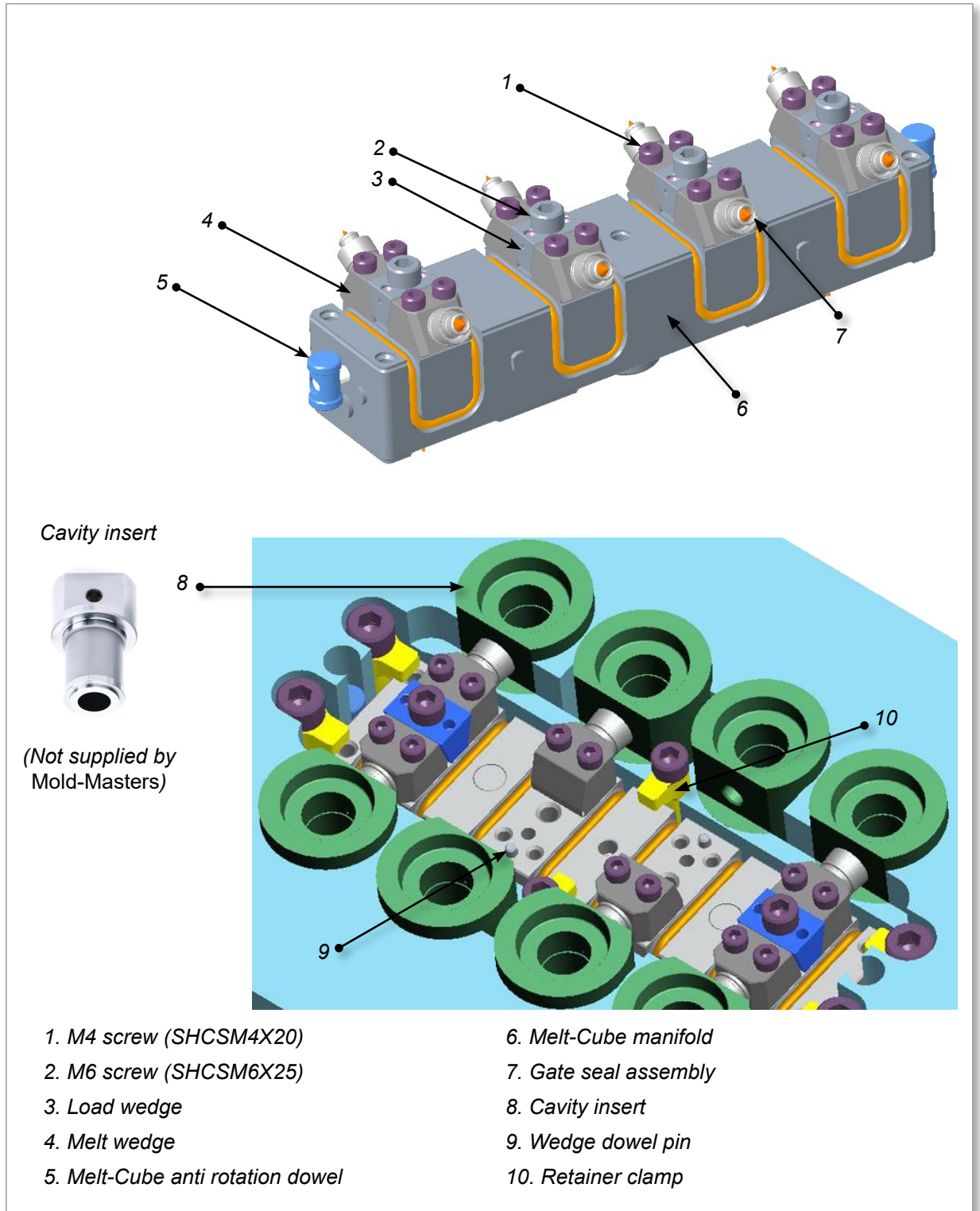


Figure 5-80 Melt-Cube design A components

5.25.5.1 Gate Seal Assembly

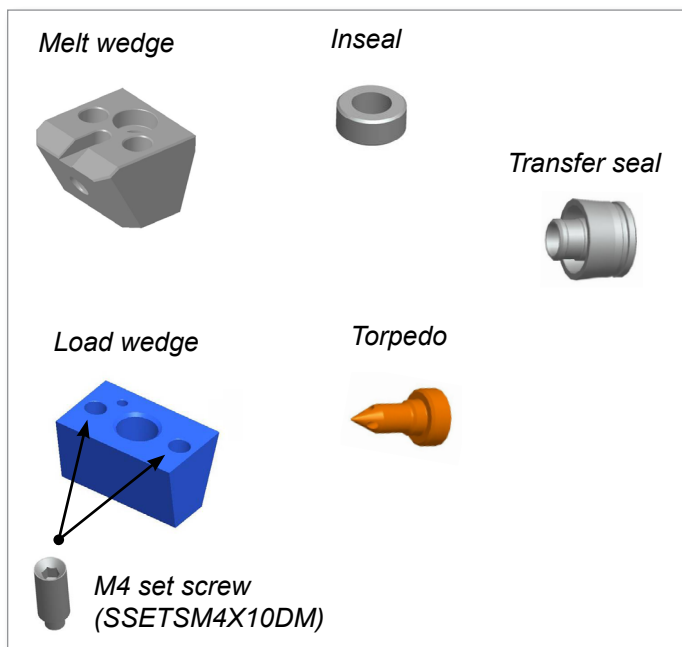


Figure 5-81 Gate seal assembly

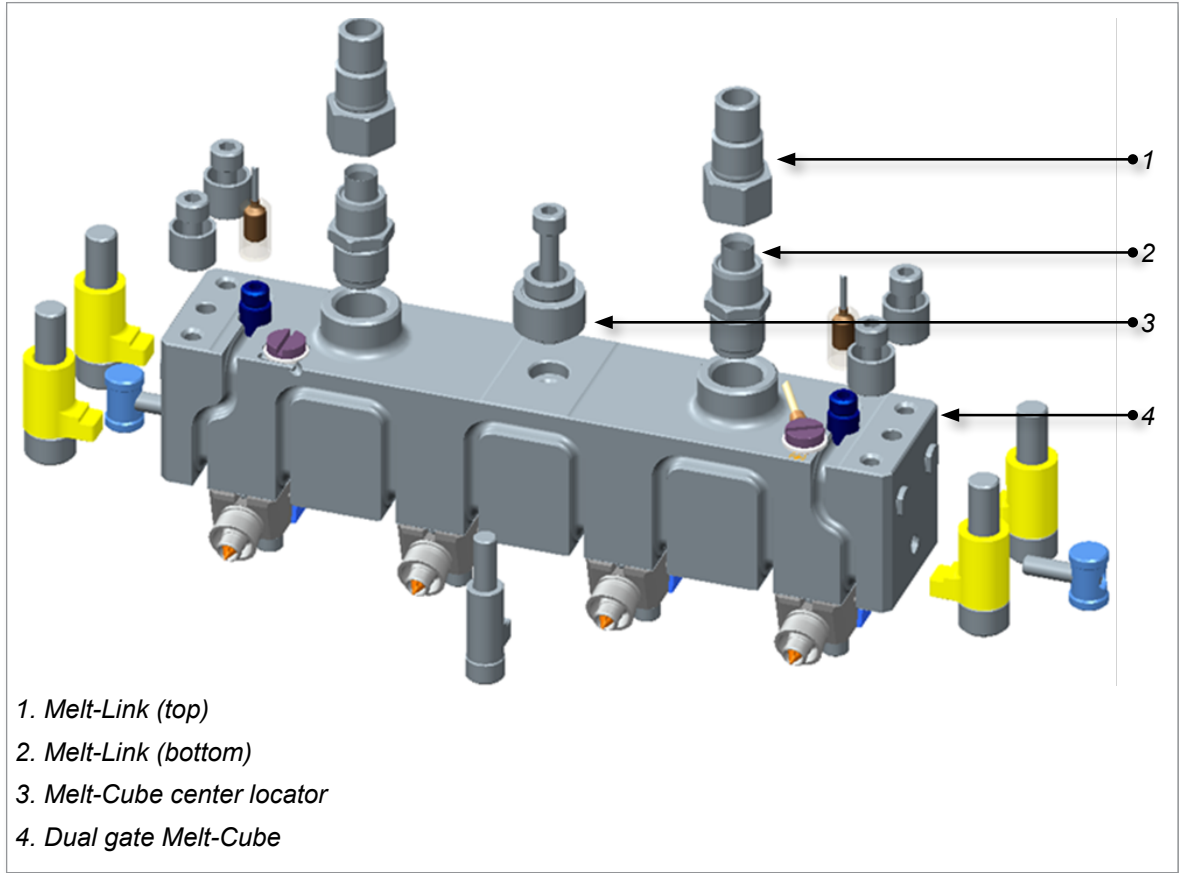
5.25.5.2 Maintenance Toolkit

- Melt-Cube inseal extraction tool (EXTOOL20)



- 2 mm (0.08 in.) hex wrench - use for M4 set screws
- 3 mm (0.12 in.) hex wrench - use for M4 screws
- 5 mm (0.2 in.) hex wrench - use for M6 screws
- SHCSM5x90mm (2) - to extract melt wedge
- SHCSM4x60mm (2) - to extract load wedge

5.25.5.3 Dual Nozzle Assembly



5.25.5.4 Inspecting

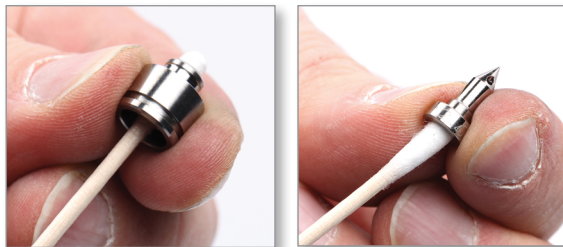
Inspect the critical dimensions for the cavity cutout. These dimensions must match those of your general assembly drawing.

5.25.5.5 Cleaning



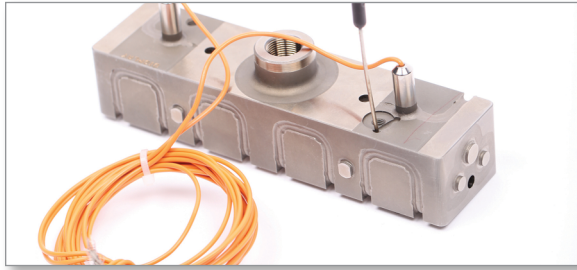
CAUTION
 Ensure that the critical surfaces are not damaged during the cleaning process.

1. Wipe down the Melt-Cube.
2. If necessary, use a cotton swab to clean narrow interior surfaces or screw threads. Spray lacquer thinner on larger surfaces, such as the manifold, to clean channels and recesses.

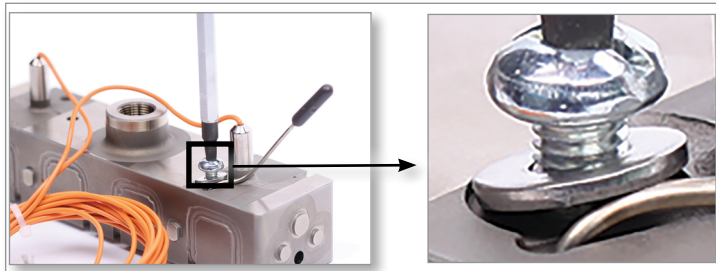


5.25.5.6 Assembling a Melt-Cube Thermocouple

1. Insert the thermocouple tip into the thermocouple hole. Make sure that the thermocouple touches the bottom of the hole.

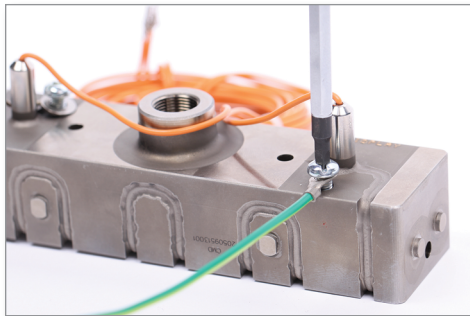


2. Bend the thermocouple back 90° to sit in the manifold channel.
3. Apply anti-seize compound to the retaining screw. Secure the thermocouple with the screw.



5.25.5.7 Assembling a Ground Wire

1. Apply anti-seize compound to the retaining screw. Secure the ground wire with the screw.

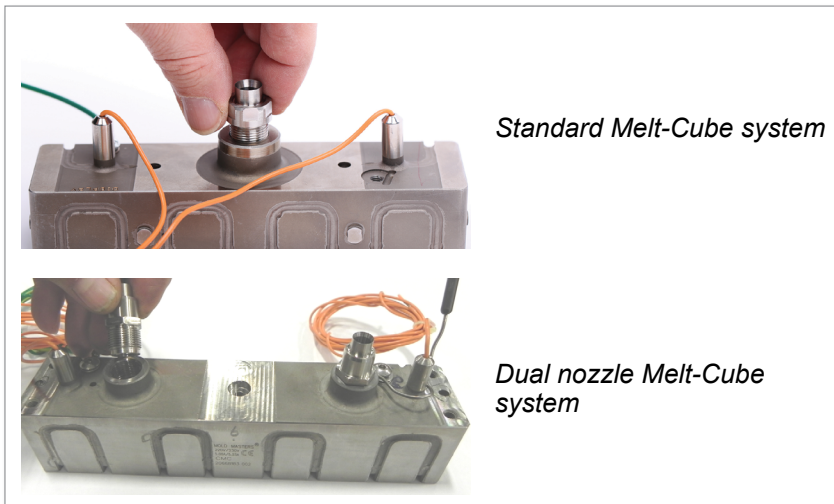


5.25.5.8 Installing a Melt Transfer Link

1. Apply anti-seize compound to the threads of the melt transfer link (top half and bottom half).



2. Thread the melt transfer link bottom half into the Melt-Cube and the melt transfer link top half into the nozzle.



CAUTION

Melt transfer links must be tightened at room temperature, between 10°C and 40°C (50°F and 104°F).

3. Tighten the melt transfer link to the value specified in the torque chart or the general assembly diagram.

Part Number	Description	Tighten Value Nm (ft-lb)	Socket Size (mm)
MTL015A	Melt Transfer Link Deci Top Half (to nozzle)	34-38 (25-28)	19
MTL016A	Melt Transfer Link Centi Top Half (to nozzle)	27-30 (20-22)	16
MTL015B	Melt Transfer Link Deci Bottom Half (to Melt-Cube)	27-30 (20-22)	17
MTL016B	Melt Transfer Link Centi Bottom Half (to Melt-Cube)	27-30 (20-22)	15

5.25.5.9 Installing in a Cavity Block

If the system has been running:

1. Make sure water to the cover plate is off, then remove the cover plate.
2. Turn on cooling to the rest of the plates, especially the cavity plates.



NOTE

Mold-Masters recommends using a separate cooling circuit for the cover plate, to be able to assemble and disassemble it without affecting other cooling circuits.

5.25.5.10 Assembling (Cold Condition)

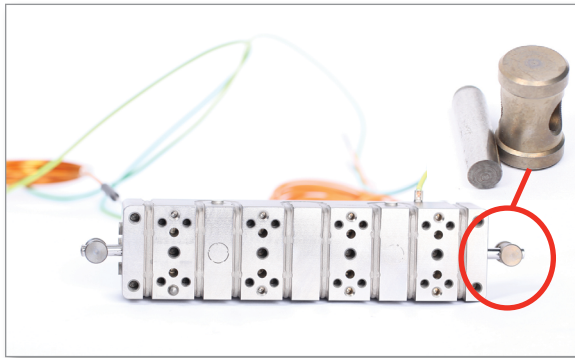


CAUTION

Failure to retighten wedge screws at process temperature could cause leaks.

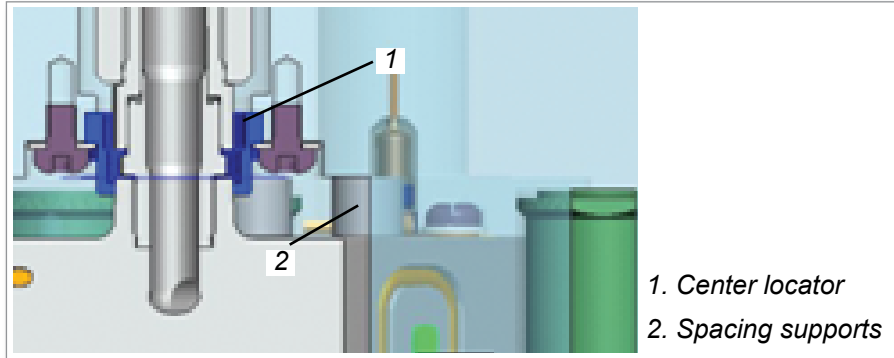
Assembly at cold condition, as follows. For clarity, an example 8-cavity demo system is shown.

1. Install Melt-Cube anti-rotation dowel in each end of the Melt-Cube.



2. Install Melt-Cube center locator into the back of the cavity block. Install spacing supports into the back of the Melt-Cube.
3. Insert Melt-Cube into the cavity block. Align the anti-rotation dowels with the slots in the cavity block, while also aligning the Melt-Cube to the Melt-Cube center locator and spacing supports.

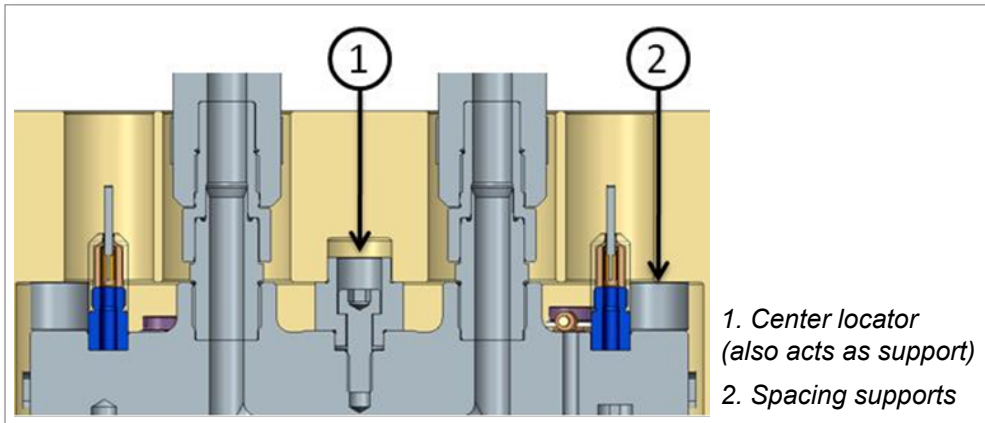




NOTE

For the dual nozzle Melt-Cube, the center locator is bolted onto the Melt-Cube.

4. Optional (for dual nozzle Melt-Cube systems): Insert the Melt-Cube into the cavity block.
Align the anti-rotation dowels and Melt-Cube center locator with the slots in the cavity block.



5. Apply anti-seize compound to the clamp SHCS. Install the proper SHCS into each retainer clamp. Install clamps over Melt-Cube at locations shown in your general assembly drawing. Tighten as specified in Table 5-3 Clamp Screw Tighten Chart.

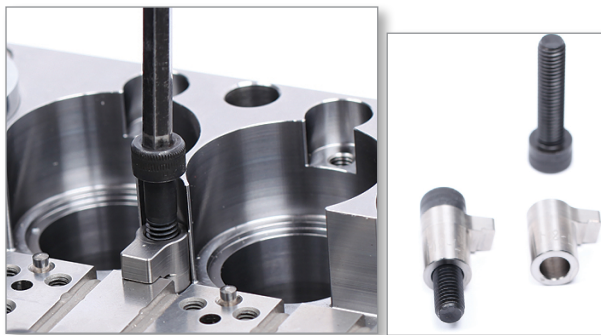
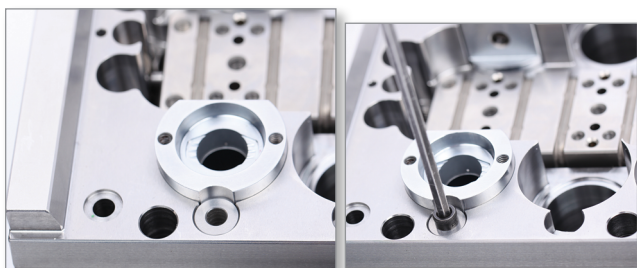


Table 5-3 Clamp Screw Tighten Chart		
SHCS	Component	Tighten Value Nm (ft-lb)
M6X35	CLAMP16	10 (7.5)
M8X35	CLAMP17	16 (12)
M8X35	CLAMP18	20 (15)

6. Install cavity inserts, if applicable, aligning hole with cavity.



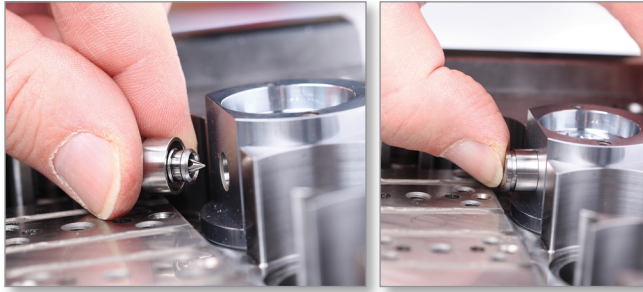
7. Any cavity alignment features, such as dowels or cams, must be properly inserted at this time. In the example below cavity side retainers / anti-rotation dowels are installed. Repeat for all cavities.



8. Prepare the gate seal assembly:
- a) Ensure transfer seal and torpedo are clean.
 - b) Install torpedo into transfer seal.



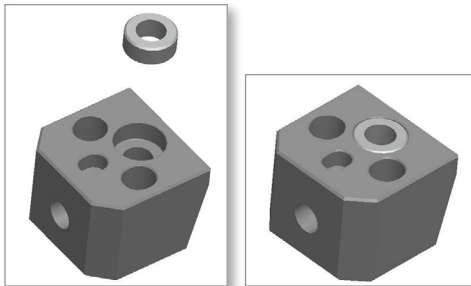
9. Ensure outside of transfer seal is clean. Slide fit transfer seal into cavity insert hole.



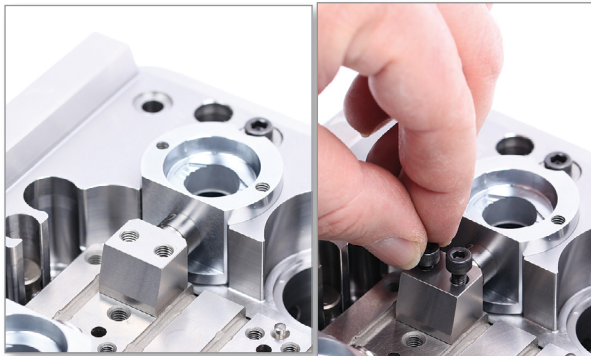
10. Install wedge dowel pins for locating melt wedges.



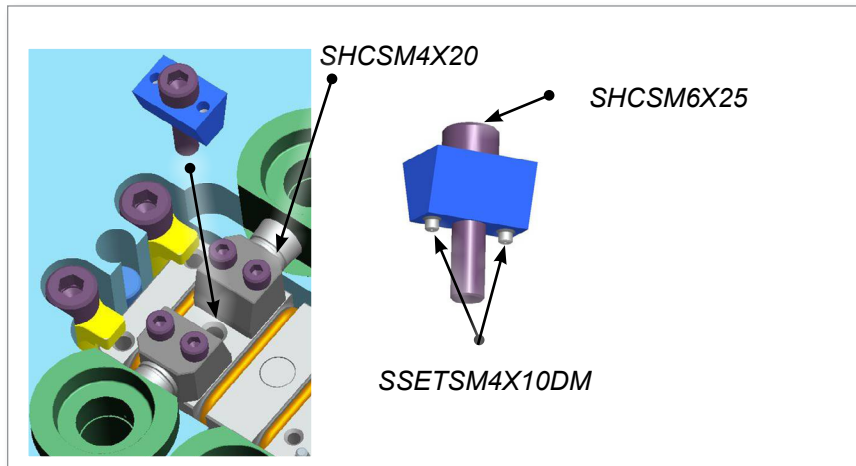
11. Ensure all melt wedge surfaces and inseals are clean. Place inseals into melt wedges.



12. While holding inseal, place melt wedge on dowel pin. Apply anti-seize compound to two SHCSM4X20. Insert melt wedge and hand tighten (less than 0.56 Nm or 5 in-lb) until head of screw bottoms. Repeat for opposite cavity melt wedge.



13. Install load wedge between melt wedges. Ensure the M4 set screws (SSETSM4X10DM) are retracted and will not contact the Melt-Cube at this stage. Apply anti-seize compound to SHCSM6X25 and hand tighten to about 0.79 Nm (7 in-lb) torque to make sure all components are in proper contact condition.
14. Loosen load wedge screw (SHCSM6X25) one full turn in counter clockwise direction to assure no engagement. Repeat for all load wedges.
15. Once the system is assembled, melt wedge and load wedge screws must be retightened at process temperature.
See 5.25.5.11 Tightening the Melt Wedge Screws (Hot Condition) on page 5-131.



5.25.5.11 Tightening the Melt Wedge Screws (Hot Condition)



WARNING - BURN HAZARD

Use a socket extension and wear heat resistant gloves when doing the following procedure.



CAUTION

Wedge screws must be tightened once the system is heated to processing temperature. Failure to do so could cause leaks.

Do not over tighten screws. Use a proper torque wrench for in-lb or fraction of Nm scale. Do not use torque wrenches with a ft-lb scale or a large scale Nm scale to tighten the M4 and M6 screws.

If the processing temperature is changed by more than 30°C (54°F) then all wedge screws should be loosened at cold condition and the assembly process repeated at cold and process temperature, as explained in the following.

1. Set the temperatures of all Hot Runner components to the processing temperature according to the startup procedure.
2. Make sure that all cooling lines other than the cover plate are connected properly.
3. After the Melt-Cube reaches the processing temperature, let it soak for at least five minutes.
4. Tighten the melt wedge screws to the torque of 1.69 Nm (15 in-lb) .
5. Tighten the screws at the center of the load wedge (load wedge screws) to the torque shown in Table 5-4.
6. Tighten the melt wedge screws to the torque shown in section Table 5-5 on page 5-132. See the following image.



Table 5-4 Load-Wedge Screw Tightens—Design A				
Screw (SHCS)	Tip Angle (°)	Transfer Seal	Temperature	Tighten Value Nm (in-lb)
M6X25	0°	TSM269	Process Temp	8.5 (75)
	15°			8.2 (73)
	30°			7.9 (70)
	45°			6.8 (60)
	60°			5.6 (50)

Table 5-5 Melt-Wedge Screw Tighten			
SHCS	Tip Angle (°)	Temperature	Tighten Value Nm (in-lb)
M4X20	All	Process Temp	3.4 (30)

7. Tighten the load wedge screws in two steps:
 - a) Tighten the two M4 set screws in the load wedge until they just touch the Melt-Cube (about 0.56 Nm or 5 in-lb).
 - b) Tighten the SHCSM6X25 screw in the center of the load wedge to a torque of 11.3 Nm (90 in-lb) to lock the load wedge in place.
8. Assemble the cavity-block cover plate.
9. Connect the cooling lines.
10. Allow all Hot Runner components to reach the processing temperature.
11. Fill the system under low pressure extrude using screw rotation.
12. Set the nozzle temperature 6°C (43°F) lower than the temperature of the Melt-Cube.

5.25.5.12 Replacing a Transfer-Seal/Torpedo



WARNING - BURN HAZARD

Use a socket extension and wear heat resistant gloves.

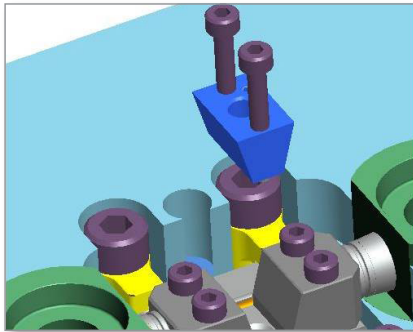


CAUTION

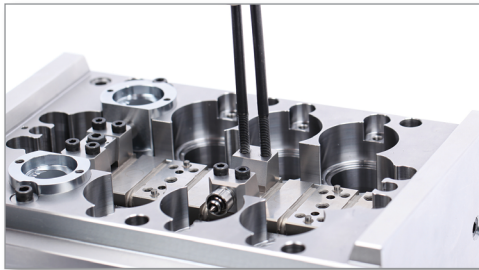
Any rough scratch may become a source of leaks. The flat sealing interfaces of the removed melt wedges should be handled very gently.

Before shutting down the molding machine and mold, use maximum screw decompression to remove as much molten plastic from the Hot Runner system as possible.

1. Make sure the Melt-Cube and related nozzle are at a temperature such that the plastic is soft enough to be able to detach runners at gate area.
2. Drain water inside cooling lines of the cover plate of the cavities and then remove the cover plate.
3. Loosen and take out the SHCSM6X25 at the center of the load wedge of transfer seal to be replaced.
4. Remove the two set screws (SSETSM4X10DM) from the load wedge.
5. Use two SHCSM4X60 screws in the tool kit to extract the load wedge.



6. Loosen and take out the two SCHSM4X20 on the melt wedge.
7. Use two spare SHCSM5X90 screws to extract related melt wedge.



8. Let the system cool down to almost room temperature.

9. Remove the transfer seal and related torpedo assembly from the cavity plate. You can use pliers (not supplied by Mold-Masters) with soft tips (brass) and a suitable hole, or you can use a screwdriver with a soft tip (brass) to pry the transfer seal at the groove at its outer diameter.



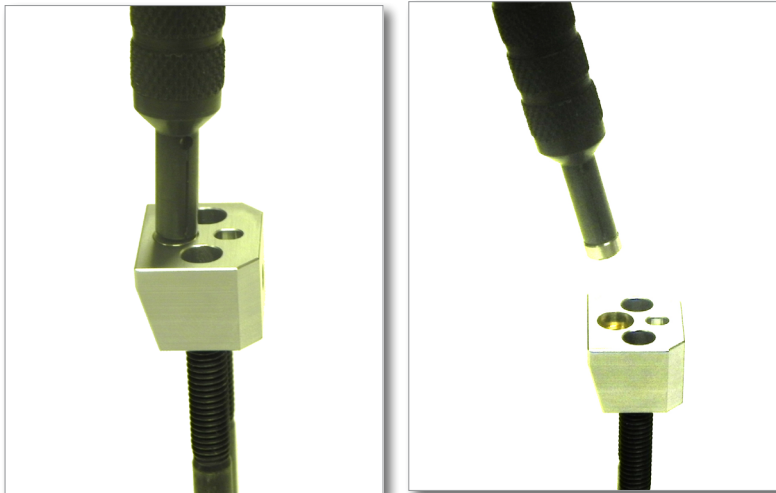
10. Remove the inseal from the melt wedge as follows:
 - a) Insert the two SHCSM5X90 screws from the toolkit into the melt wedge, to aid in handling.



NOTE

It may be helpful to secure the SHCSM5X90 screws in a vise clamp to hold the melt wedge upwards.

- b) Heat the melt wedge to approximately the melting temperature of the plastic material.
- c) Adjust the inseal extraction tool to the smallest position such that it can easily enter the inseal.
- d) Insert the extraction tool into the inseal and adjust the tool to engage the inseal.
- e) Retract the extraction tool to remove the inseal.
- f) While still hot, wipe the inseal with a cloth to remove plastic material.
- g) Allow the parts to cool.
- h) Remove the SHCSM5X90 screws from the melt wedge. See the following images.



11. Clean the inseal gently with an abrasive cloth.

12. Clean the sealing surfaces of the removed melt wedges with a nylon pad (1,200–1,500 grit; Scotch-Brite: S ULF (silicon carbide ultra-fine)):
 - a) Place the melt wedge on a completely flat surface.
 - b) Rub the melt wedge surfaces gently on the nylon pad for a few strokes.



13. Replace any parts (usually the torpedo).
14. Loosen the screws (SHCSM4X20) on the other side of the melt wedge so that the torque is only 5 in-lb (0.56 Nm).
15. Reassemble following steps in 5.25.5.10 Assembling (Cold Condition) on page 5-126. Complete these steps for both sides of any pair of seals that have been loosened to have balanced forces on interfaces of both sides during reassembly.

5.25.6 Melt-Cube Design B



CAUTION

All cleaning, assembly and installation procedures for the Melt-Cube must be done at room temperature, between 10°C and 40°C (50°F and 104°F). Failure to do so may cause damage to parts.

5.25.6.1 Components

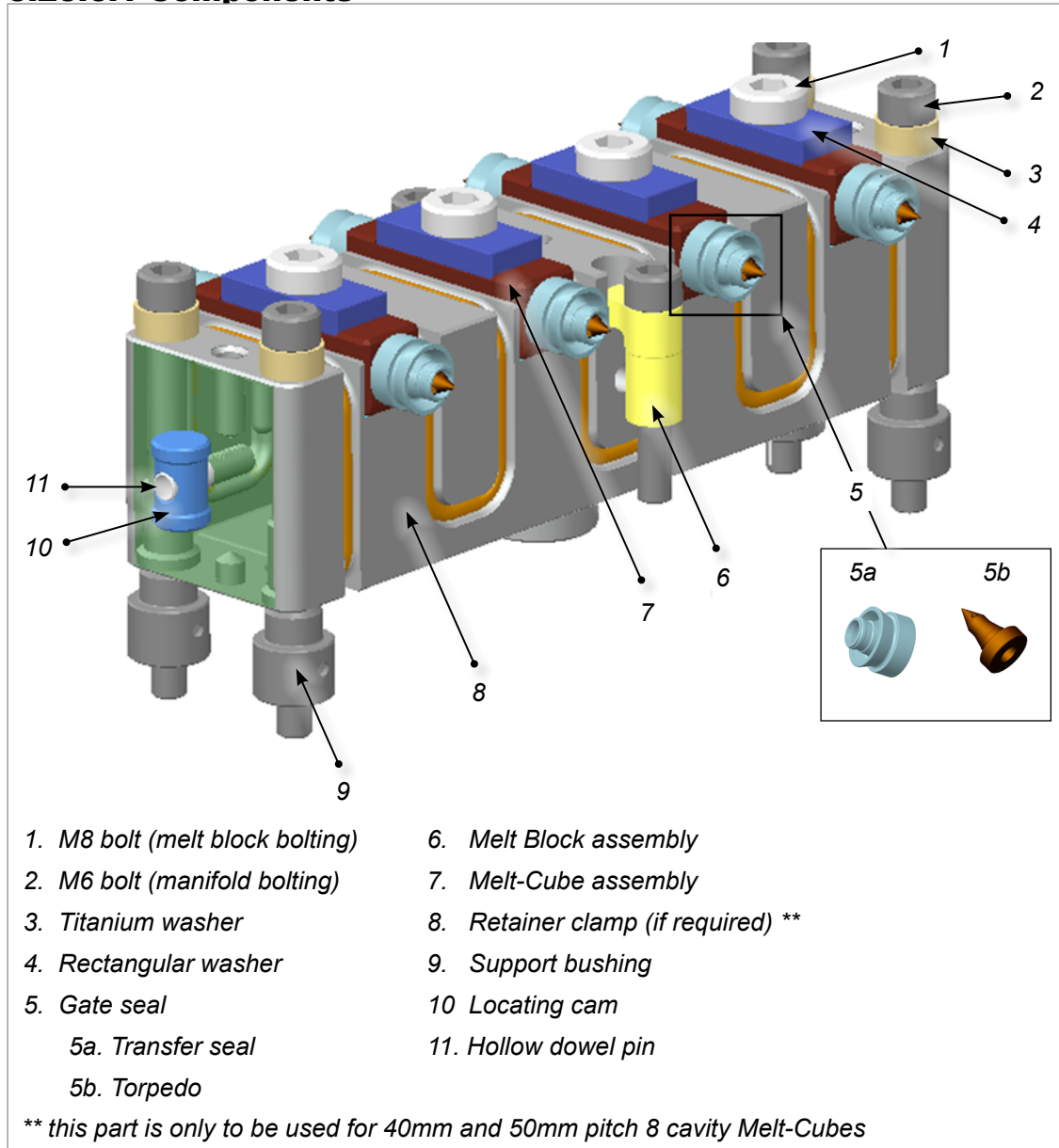


Figure 5-82 Melt-Cube Design B components

5.25.6.2 Maintenance Toolkit

Toolkit MCKITM10 has two components:

- M10-1.5 jack bolt (SHCSM10X50-A) — see Figure 5-83
- Needlenose pliers (COTS0254)

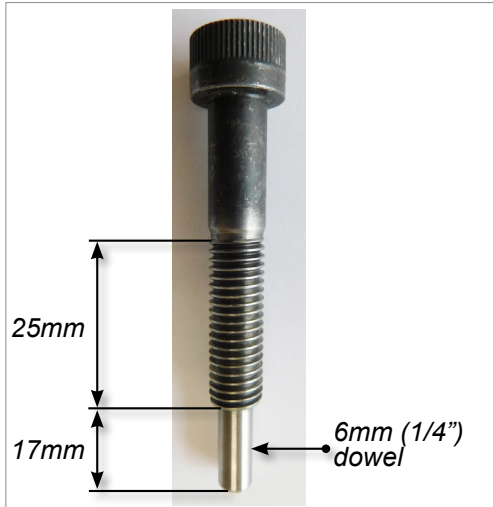


Figure 5-83 M10-1.5 jack bolt (SHCSM10X50-A)

5.25.6.3 Inspecting

Inspect and document the critical dimensions for cavity cutout as shown in Figure 5-84. The measure critical dimensions must match those of your general assembly drawing.

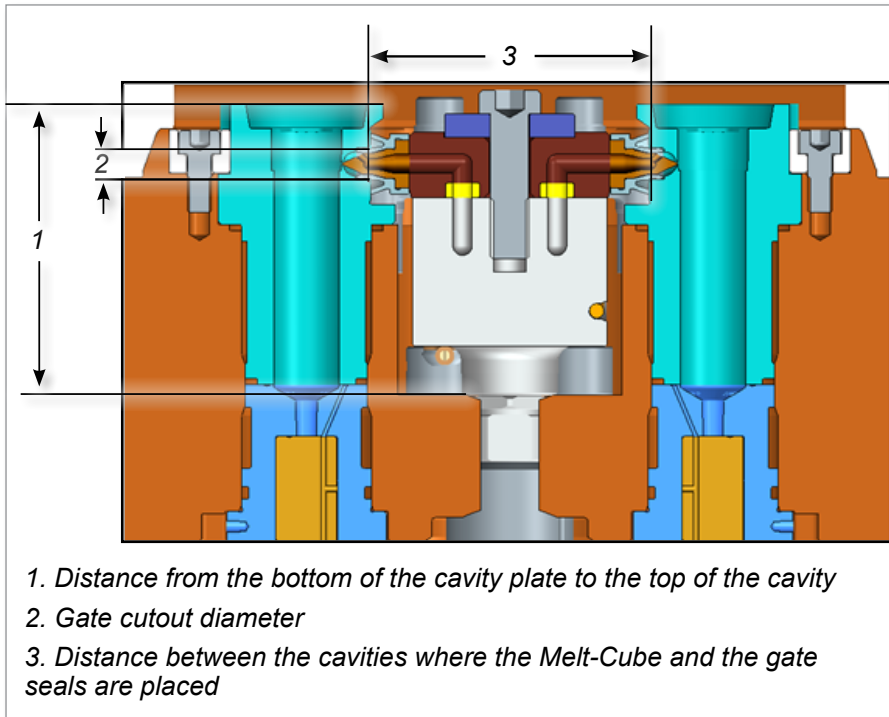


Figure 5-84 Critical cutout dimensions

5.25.6.4 Cleaning

When doing the following cleaning process, make sure that the critical surfaces are not damaged.

1. Clean any plastic residue from hot runner interface surfaces. See Figure 5-85.

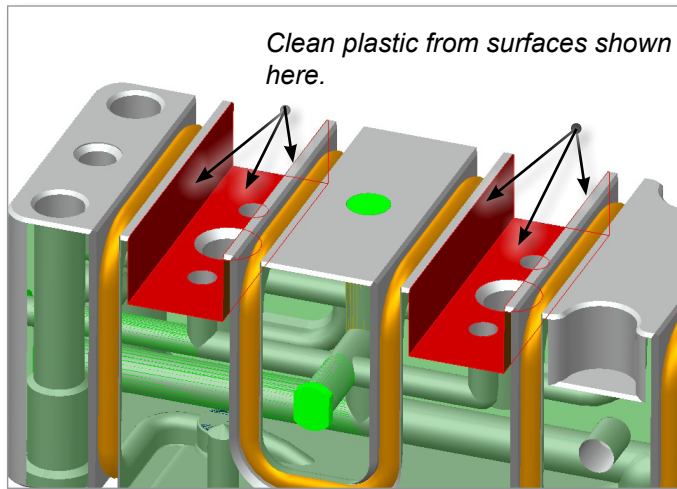


Figure 5-85 Remove plastic residue from surfaces

2. Clean the manifold interfaces with a fine grade (400 or 600 grit) polishing stone. See Figure 5-86.

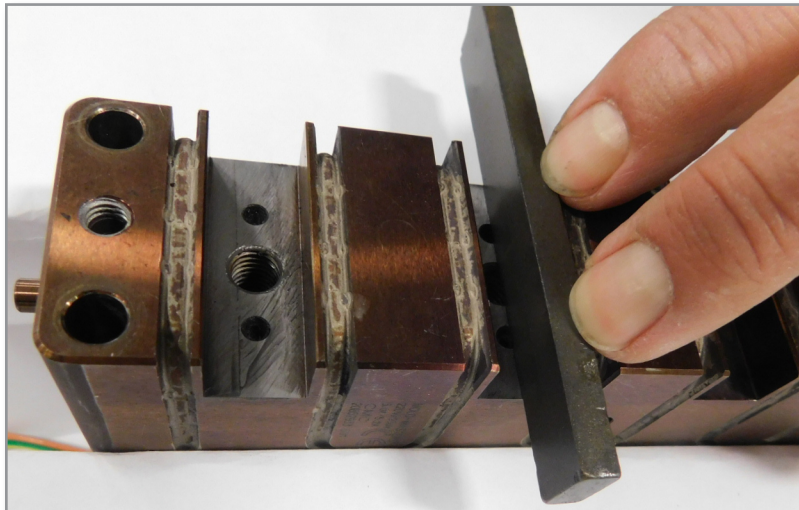


Figure 5-86 Clean manifold interfaces

3. Wipe down the melt block critical surface and the Melt-Cube manifold interfaces with lacquer thinner.

4. If necessary, clean the interior surfaces and screw threads with a cotton swab. See Figure 5-87.

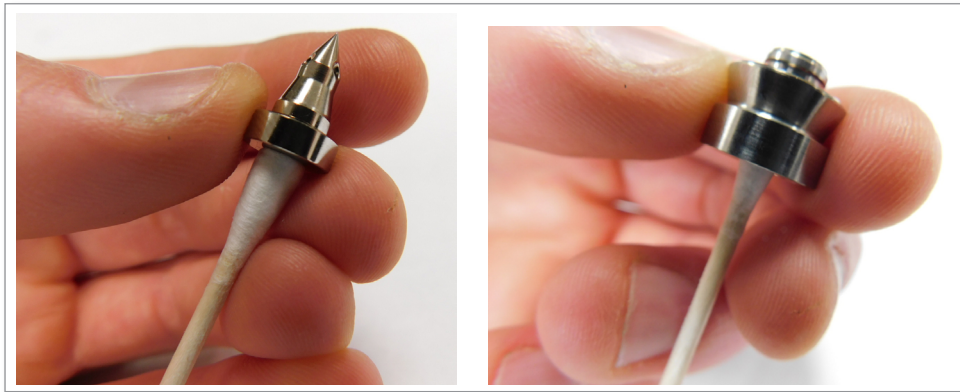


Figure 5-87 Clean torpedo and transfer seal

5.25.6.5 Installing a Thermocouple

1. Insert the thermocouple tip into the thermocouple hole. See Figure 5-88. Make sure that the thermocouple touches the bottom of the hole.

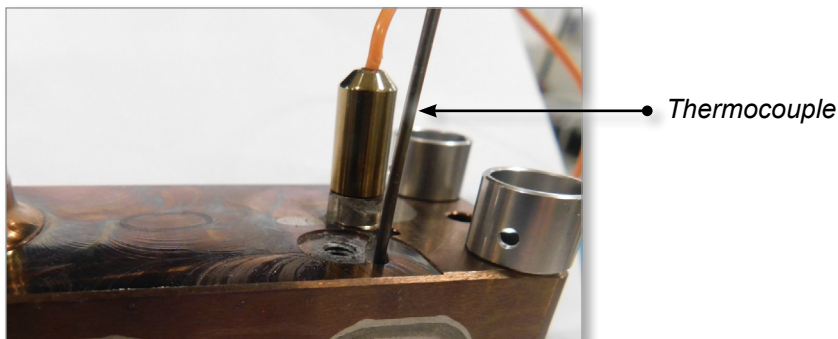


Figure 5-88 Insert thermocouple tip

2. Bend the thermocouple back 90° to sit in the manifold channel. See Figure 5-89.

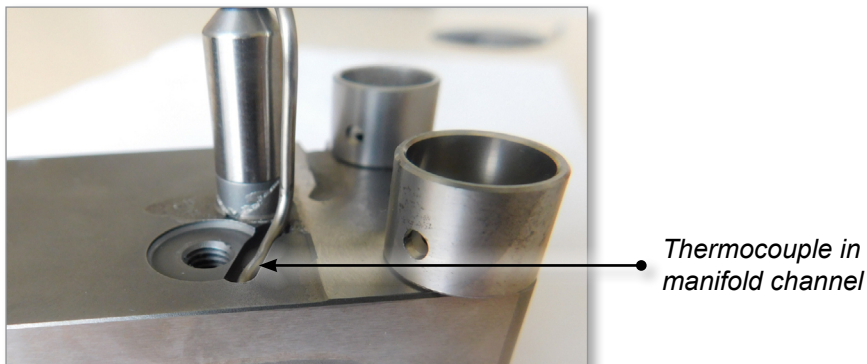


Figure 5-89 Bend thermocouple

3. Apply anti-seize compound to the retaining screw and secure the thermocouple with the screw.



5.25.6.6 Attaching a Ground Wire

1. Apply anti-seize compound to the retaining screw.
2. Secure the ground wire with the retaining screw. See Figure 5-90.

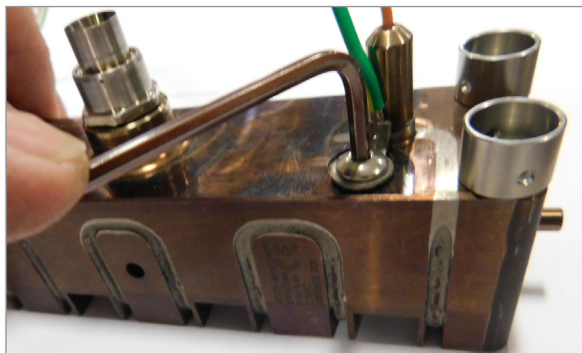


Figure 5-90 Secure the ground wire

5.25.6.7 Installing a Melt Transfer Link



CAUTION

The following procedure must be done with the Melt-Cube at room temperature, between 10°C and 40°C (50°F and 104°F).

1. Apply anti-seize compound to the threads on the top and bottom halves of the melt transfer link.
2. Install the bottom half of the melt transfer link on the Melt-Cube. See the following image.



Figure 5-91 Install the bottom half of the melt transfer link

3. Install the top half of the melt transfer link on the nozzle. See the following image.

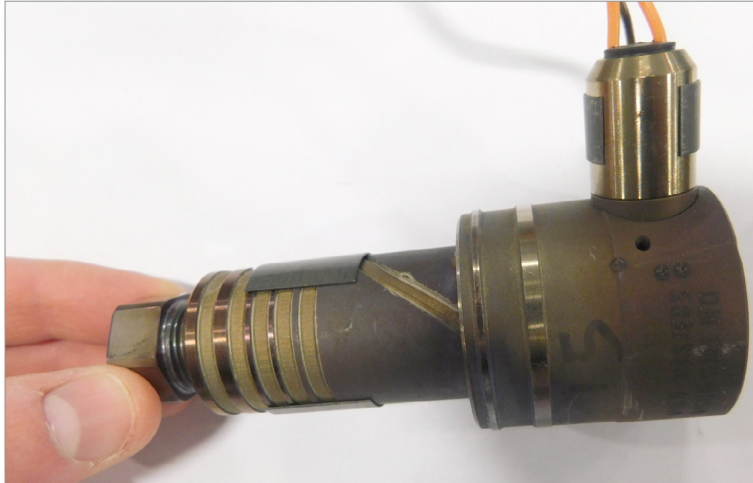


Figure 5-92 Installing the top half of the melt transfer link

4. Tighten the melt transfer link to the torque value specified in Table 5-6.

Table 5-6 Melt-Cube Design B: Melt Transfer Link Tighten Chart			
Part Number	Description	Tighten Value Nm (ft.-lb)	Socket Size (mm)
MTL015A	Melt Transfer Link Deci Top Half (to nozzle)	34-38 (25-28)	19
MTL016A	Melt Transfer Link Centi Top Half (to nozzle)	27-30 (20-22)	16
MTL015B	Melt Transfer Link Deci Bottom Half (to Melt-Cube)	27-30 (20-22)	17
MTL016B	Melt Transfer Link Centi Bottom Half (to Melt-Cube)	27-30 (20-22)	15



NOTE

Torque values can also be found on your general assembly drawing.

5.25.6.8 Assembling



CAUTION

The following procedure must be done with the Melt-Cube at room temperature, between 10°C and 40°C (50°F and 104°F). Failure to do so may cause damage to parts.

1. Install the anti-rotation dowel into each end of the Melt-Cube. See Figure 5-93.

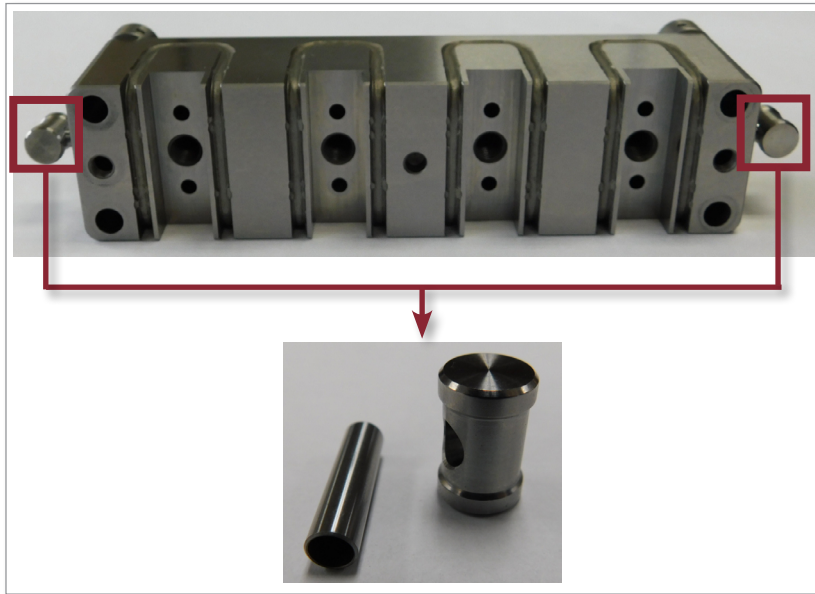


Figure 5-93 Install the anti-rotation dowel

2. Install the Melt-Cube center locator into the bottom of the cavity block and finger tighten. See Figure 5-94.



Figure 5-94 Install the center locator

3. Install the four support bushings into the bottom of the Melt-Cube manifold and hand tighten. See Figure 5-95.

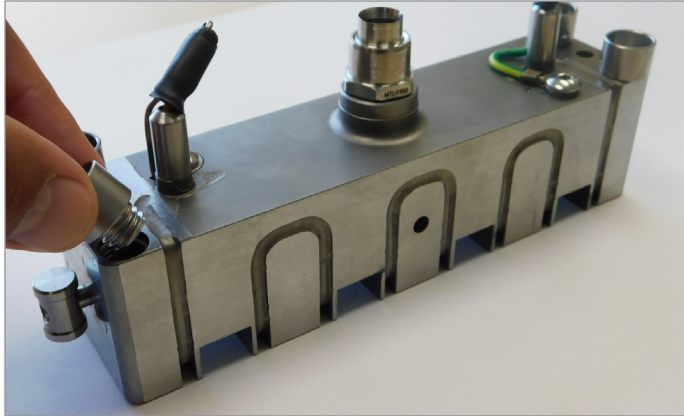


Figure 5-95 Install bushings

4. Place the Melt-Cube manifold into the cavity block using M6 lifting bolts. See Figure 5-96.



Figure 5-96 Install Melt-Cube manifold

5. Install the four titanium washers and the four M6 bolts. Tighten to 14 Nm (10 ft.-lb). See Figure 5-97.

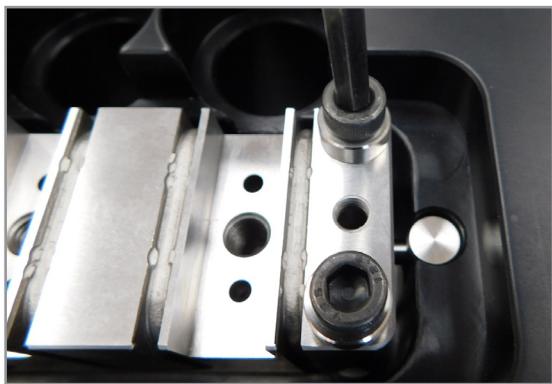


Figure 5-97 Install washers and bolts

- For 8-drop Melt-Cube systems with either a 40 or a 50 mm pitch, a side clamp must be installed and tightened to 10 Nm (7.5 ft.-lb). See Figure 5-98.

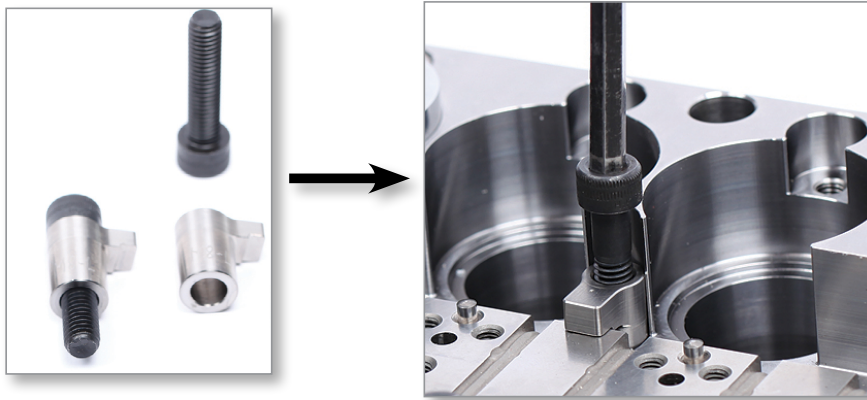


Figure 5-98 Install side clamp - specific systems only

- Install the torpedo into the transfer seal. See Figure 5-99.



Figure 5-99 Install torpedo

5.25.6.9 Installing Gate Seals and Cavity Inserts



CAUTION

The following procedure must be done with the Melt-Cube at room temperature, between 10°C and 40°C (50°F and 104°F). Failure to do so may damage parts.

- Install the cavity insert into the cavity block.

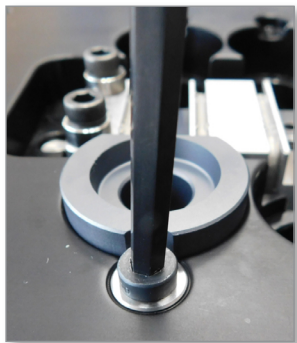


Figure 5-100 Install cavity insert

2. Install the gate seal into the cavity insert. See Figure 5-101.

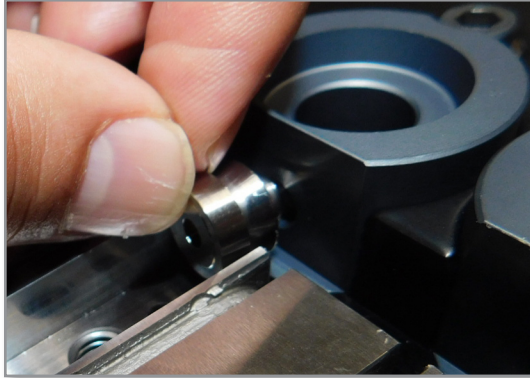


Figure 5-101 Install gate seal

5.25.6.10 Installing a Melt Block



CAUTION

The following procedure must be done with the Melt-Cube at room temperature, between 10°C and 40°C (50°F and 104°F). Failure to do so may cause damage to parts.

1. Install the melt block assembly with an M10 lifting bolt or by hand. See Figure 5-102 and Figure 5-103.

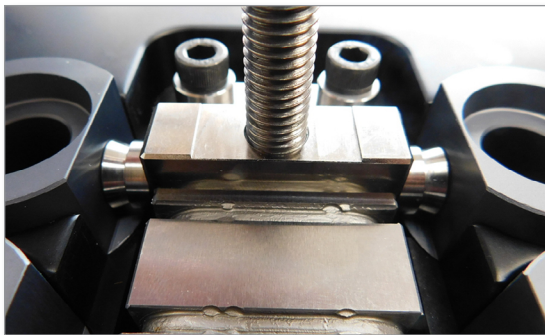


Figure 5-102 Install with an M10 lifting bolt

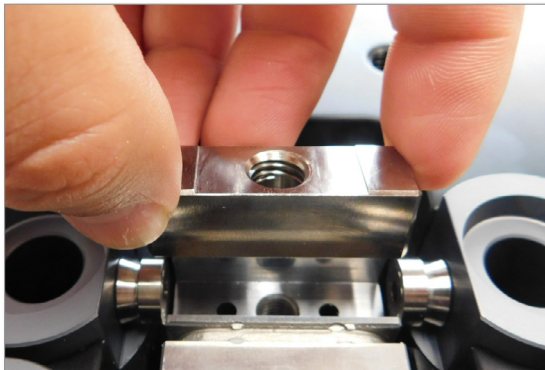


Figure 5-103 Install by hand

2. Insert the rectangular washer and the M8 bolt onto the melt block. Tighten bolt at 27 Nm (20 ft.lbs). See Figure 5-104.

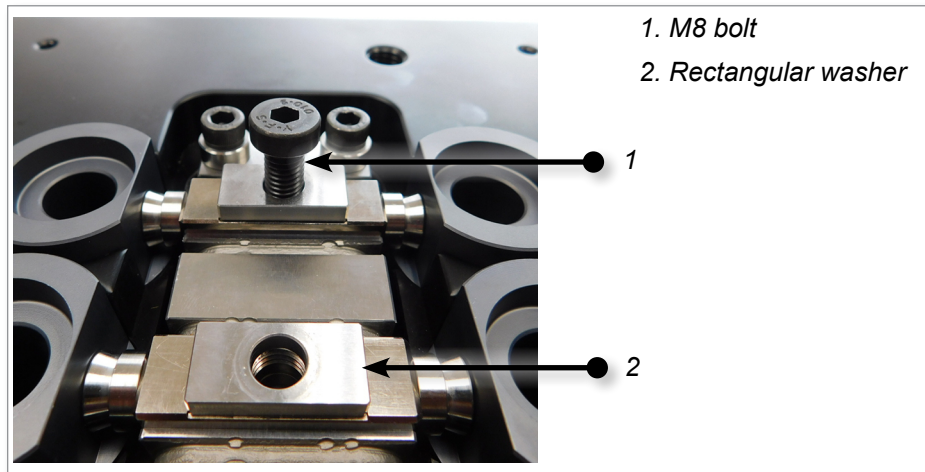


Figure 5-104 Install rectangular washer and bolt

5.25.6.11 Disassembling a Transfer-Seal/Torpedo and a Melt Block



CAUTION

This procedure must be done with the Melt-Cube at a temperature between 10°C and 40°C (50°F and 104°F). Failure to do so may cause damage to parts.



CAUTION

The flat sealing interfaces of the removed melt blocks should be handled very gently. Any scratch may become a source of leaks.

1. Before shutting down the molding machine and mold, use maximum screw decompression to remove as much molten plastic from the Hot Runner system as possible. If hard resin was used in the system, purge with a softer resin before shutting down.
2. Drain the water inside the cooling lines of the cover plate of the cavities.
3. Remove the cover plate.
4. Use the jack bolt from the toolkit to carefully extract the melt block.

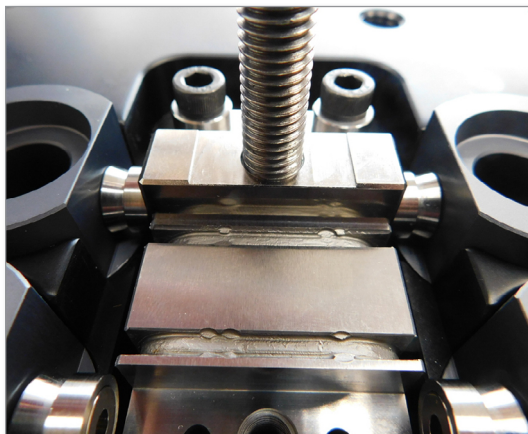


Figure 5-105 Extract the melt block

5. Insert the extraction tool or pliers into the groove of the transfer seal, and gently twist the gate seal out of the cavity. See the following or Figure 5-106.

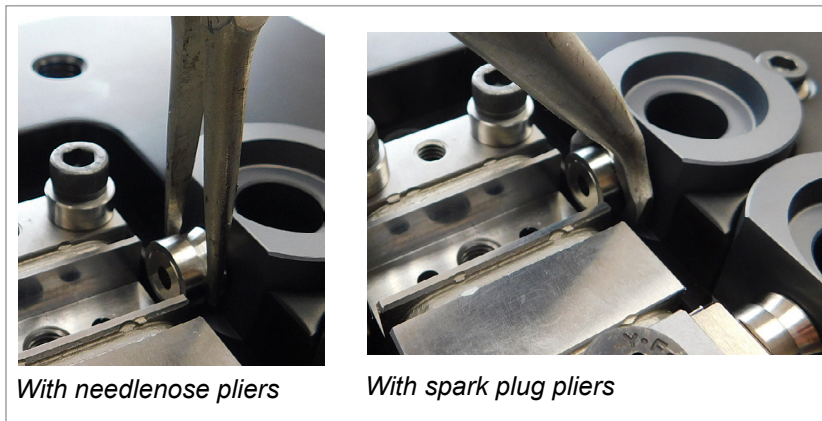
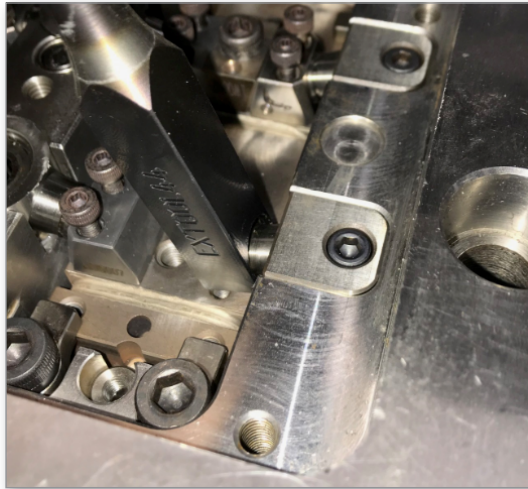


Figure 5-106 Remove the gate seal

6. Gently clean the sealing interfaces of the melt block and the gate with an abrasive cloth. See Figure 5-107.



Figure 5-107 Clean the melt block and gate seal

7. Clean the manifold interfaces on Melt-Cube using a fine polishing stone. See Figure 5-86 Clean manifold interfaces on page 5-138.
8. Inspect the sealing surfaces for any damage. If the sealing surfaces on either the gate seal or the melt block show significant damage, the part should be replaced to avoid leaks.
9. Reassemble the Melt-Cube. See 5.25.6.8 Assembling on page 5-142.

5.25.6.12 Installing a Melt-Cube in a Cavity Block

If the system has been running:

1. Make sure water to the cover plate is off.
2. Remove the cover plate.
3. Turn on cooling to the rest of the plates, especially the cavity plates.

**NOTE**

Mold-Masters recommends using a separate cooling circuit for the cover plate, to be able to assemble and disassemble it without affecting other cooling circuits.

5.26 DeXa Systems (Side Gating)



WARNING - READ MANUAL

Read Section 3 - Safety on page 3-1 before integrating, operating, or doing maintenance procedures on a DeXa system.

- Identify the type of DeXa nozzle in your system: two- or four-tip.
- Nozzle gates are controlled by separate individual heater zones. It is important to identify the zone with the appropriate gate. See 5.26.6 Orientations of Nozzle Terminal Ends and Wiring Diagrams on page 5-152 for further details.

5.26.1 Two-Tip DeXa Nozzle

The two-tip DeXa nozzle:



Figure 5-108 Two-tip DeXa nozzle (bottom view)

5.26.2 Four-Tip DeXa Nozzle

The four-tip DeXa nozzle:

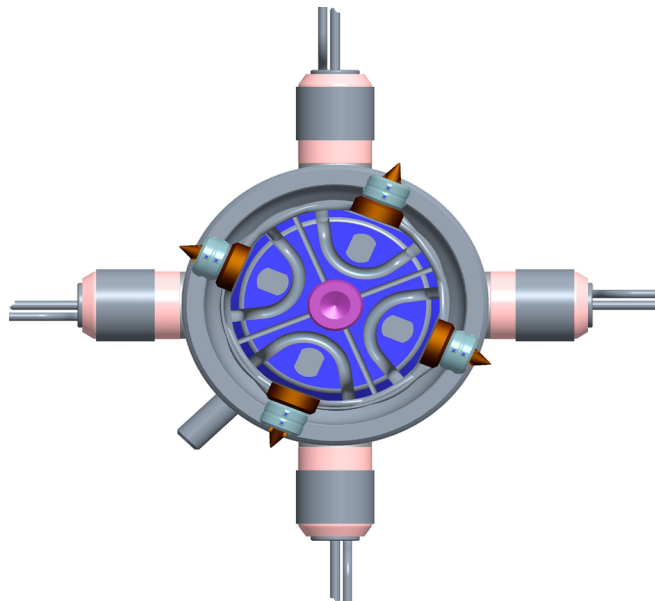


Figure 5-109 Four-tip DeXa nozzle (bottom view)

5.26.3 DeXa Nozzle Package—Four Tip

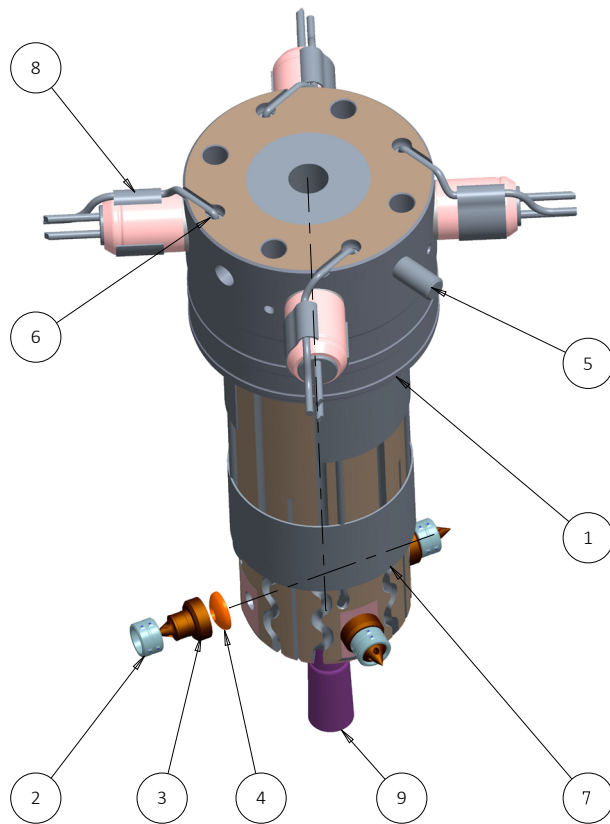


Figure 5-110 Four-tip DeXa nozzle

Table 5-7 Four-Tip DeXa Nozzle Package		
Figure Callout No.	Quantity	Description
1	1	Nozzle
2	4	Transfer seal
3	4	Torpedo
4	4	Nozzle inseal for side gate
5	1	Dowel pin
6	4	Ungrounded thermocouple
7	2	Nozzle-thermocouple retaining clip
8	4	Terminal-thermocouple retaining clip
9	1	Speed-LOK center bolt

5.26.4 Installing a DeXa Nozzle

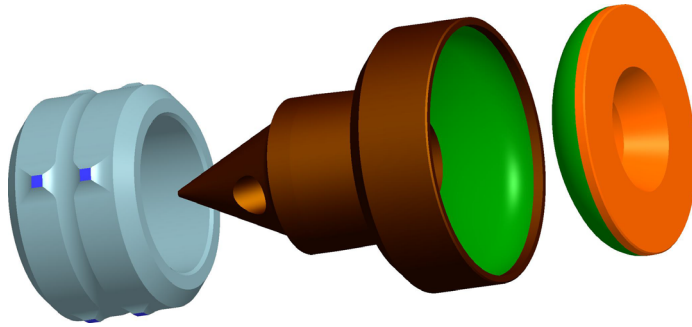


Figure 5-111 Gate seal package (left to right: transfer seal, Torpedo, and inseat)

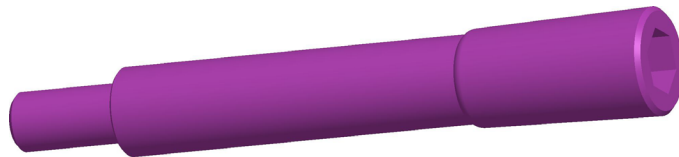


Figure 5-112 Speed-LOK center bolt (torque: 7.34–9.60 Nm (65–85 in-lb))

1. Make sure that all contact surfaces of the gate seal package are clean.
2. Install the Torpedo in the transfer seal.
3. Apply food-grade grease to the spherical surface of the Torpedo.
4. Insert the inseat on the Torpedo and rotate to ensure full contact.
5. Install the gate seal package (transfer seal, Torpedo, and inseat) in the cavity block. Make sure the gate seal package is fully seated in the cavity block.
6. Install the Speed-LOK center bolt in the nozzle. Make sure that the center Speed-LOK is loose when installing the DeXa nozzle.
7. Install the DeXa nozzle body.
8. Tighten the Speed-LOK center bolt until it fully stops (**torque: 7.34–9.60 Nm (65–85 in-lb)**) to supply a mechanical preload to the gate seals,

5.26.5 Disassembling a DeXa Nozzle

1. Make sure that the Speed-LOK center bolt is completely loose before disengaging the nozzle body from the gate seals.
2. Remove the nozzle body from the cavity plate.
3. Remove the gate seal packages from the cavity plate.
4. Disassemble the gate seal packages into the inseat, Torpedo, and transfer seal. See Figure 5-111 Gate seal package (left to right: transfer seal, Torpedo, and inseat) for further details.

5.26.6 Orientations of Nozzle Terminal Ends and Wiring Diagrams

Nozzle gates are controlled by separate individual heater zones. It is important to identify the zone with the appropriate gate. Each gate terminal end of the heater is opposite to the gate. Each gate thermocouple (TC) is arranged according to the gate location.

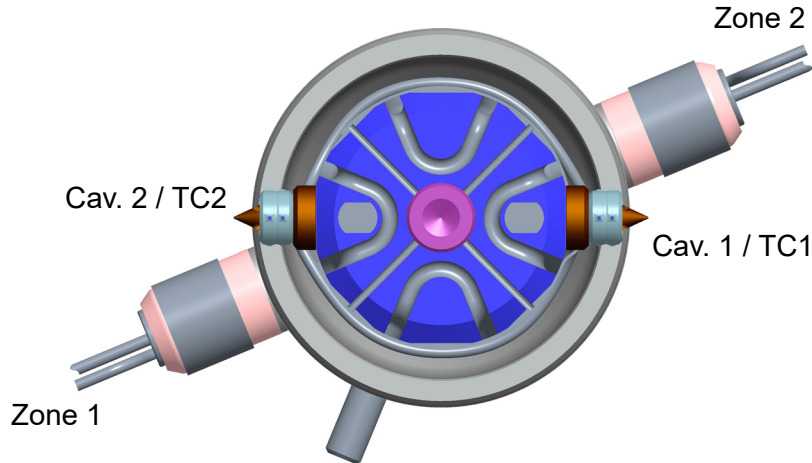


Figure 5-113 Orientation and wiring of the two-tip DeXa nozzle

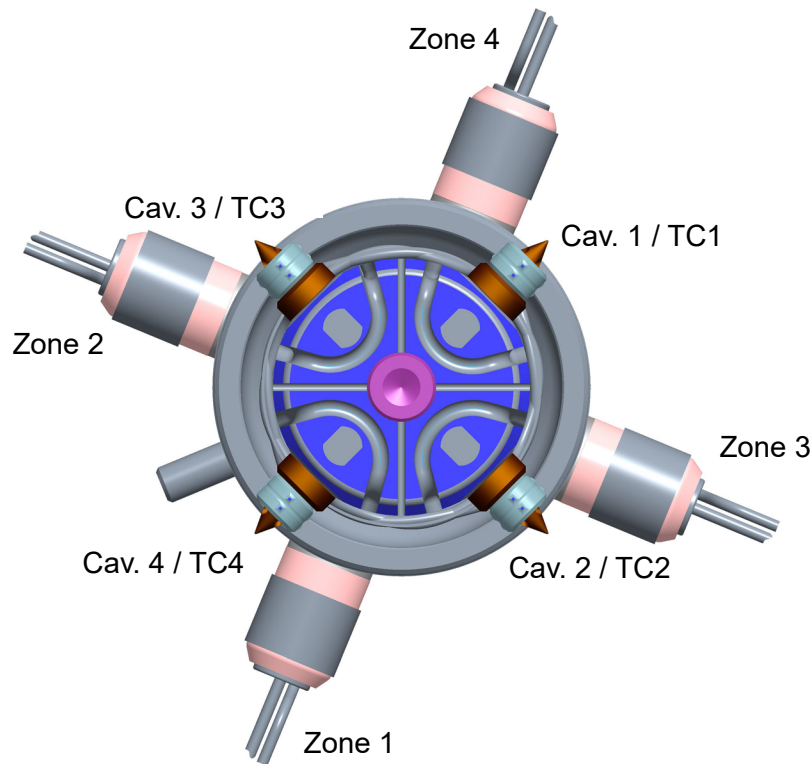


Figure 5-114 Orientation and wiring of the four-tip DeXa nozzle

Section 6 - Hot Half Assembly



WARNING - READ MANUAL

Read Section 3 - Safety on page 3-1 before assembling the Hot Half.

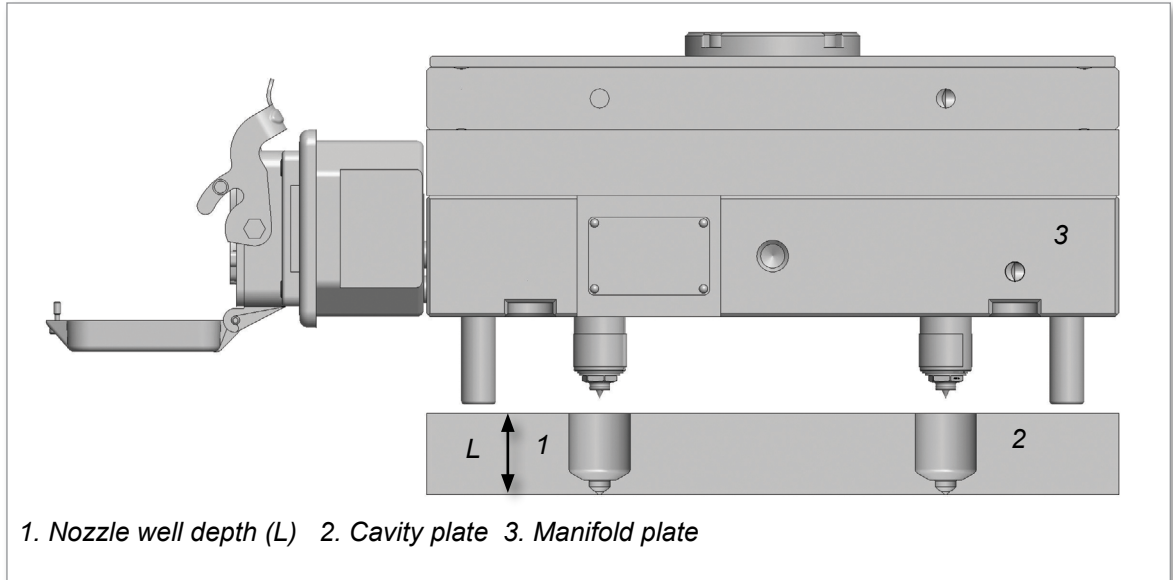


Figure 6-1 Nozzle depth

6.1 Assembling a Hot Half



WARNING - CRUSH HAZARD

Make sure that the lifting eyebolt, lifting chain, and crane are rated to support the weight of the plate.



WARNING - LOCKOUT/TAGOUT

When required, lockout and tagout the machine according to the documented procedures. Failure to do so may result in serious injury or death.



CAUTION

Do not assemble/disassemble the cavity plate with the valve pins forward. Valve pins must be retracted before installing the cavity plate.



CAUTION

Install the cavity plate when nozzle temperatures are less than 55°C (130°F) hotter than the temperature of the cavity plate. Otherwise, the nozzles will have expanded too much and may be damaged during insertion.



NOTE

For valved systems, the Hot Half is provided with valve pins installed. Refer to your general assembly drawing for instructions. For valve assembly details refer to 5.14 Hydraulic and Pneumatic Actuators on page 5-39.

1. Check that the nozzle well depth (L) in the cavity plate is to Mold-Masters specifications. See Figure 6-1.
2. Attach a crane that is rated to support the weight of the cavity plate.
3. Check that all wires are in the retainer grooves.
4. Be careful to not damage the gates seals when installing the cavity plate to the manifold plate.
5. Leave the Hot Half in a horizontal position.
6. Ensure the cavity plate is clean and undamaged before assembly.
7. Heat the manifolds to 180°C (365°F).

**CAUTION**

Do not install the cavity plate on a cold manifold. Failure to do so may damage parts.

**NOTE**

Heating the manifolds expands the system slightly to eliminate the cold clearance and ensures the nozzles are perpendicular to the manifold.

8. When the manifolds reach 180°C (365°F), install the cavity plate on the manifold plate. If the plate does not assemble easily, remove the cavity plate and check for interference. Be careful to not damage the gate seals.
9. Install the mounting screws and torque to the required specifications. See the Table 4-4 Tightens of Plate Assembly Screws on page 4-4.
10. Attach a crane that is rated to support the weight of the mold (Cold Half).
11. Lock out and tag out the machine according to the documented procedures.
12. Latch the Hot Half to the Cold Half.
13. Install the mold into the molding machine. Refer to the machine manufacturer's documentation for procedures.
14. Tighten the mold mounting screws to required specifications. Refer to the machine manufacturer's documentation for torque values.
15. Connect wire lines, hydraulic, pneumatic and electrical components, as required.
16. Remove latches.

6.2 Installing a Stack-Mold Cavity Plate



WARNING

Ensure the lifting eyebolt, lifting chain and crane are rated to support the weight of the plate. When required, lockout and tagout the machine according to the documented procedures. Failure to do so may result in serious injury or death.



CAUTION

Install the cavity plates before nozzle temperatures become more than 55°C (130°F) hotter than the cavity plates. Otherwise the nozzles will have expanded too much and may be damaged during insertion.



CAUTION

Be careful to not damage the gate seals when attaching the cavity plates to the manifold plate.



NOTE

The assembly sequence will vary depending on the stack mold design. The following instructions should be considered as guidelines only.

1. Check that the nozzle well depth (L) in the cavity plate is to Mold-Masters specifications. See Figure 6-1.



NOTE

For valved systems, the Hot Half is provided with valve pins installed. Refer to your general assembly drawing for instructions. For valve assembly details refer to 5.14 Hydraulic and Pneumatic Actuators on page 5-39.

2. Make sure that the valve pins are retracted. Do not assemble / disassemble the cavity plates with the valve pins forward.
3. Attach a crane that is rated to support the weight of the cavity plates.
4. Check that all wires are in the retainer grooves.
5. Ensure the cavity plates are clean and undamaged before assembly.
6. Heat all manifolds to 180°C (365°F).



CAUTION

Do not install the cavity plate on a cold manifold. Failure to do so may damage parts.



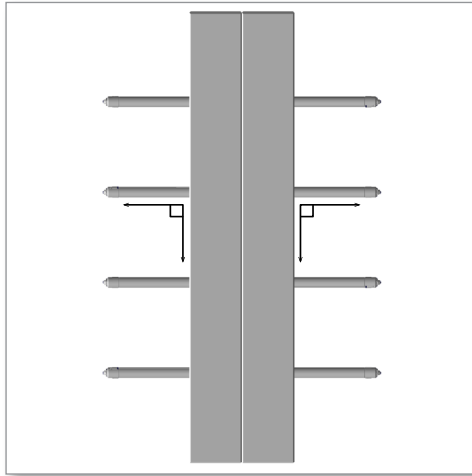
NOTE

Heating the manifolds expands the system slightly to eliminate the cold clearance and ensures the nozzles are perpendicular to the manifold.



CAUTION

Do not install the cavity plate on a cold manifold. Heating the manifolds expands the system slightly to eliminate the cold clearance and ensures the nozzles are perpendicular to the manifold.



7. When the manifolds reach 180°C (365°F), install the cavity plates on the manifold plate. If the plates do not assemble easily, remove the cavity plates and check for interference. Be careful to not damage the gate seals.
8. Install the mounting screws and torque to the required specifications. See the Table 4-3 Tightens of System Assembly Screws on page 4-4.
9. Attach a crane that is rated to support the weight of the mold.
10. Lock out and tag out the machine according to the documented procedures.
11. Latch the center section to the Cold Half.
12. Install the mold into the molding machine. Refer to the machine manufacturer's documentation for procedures.
13. Tighten the mold mounting screws to required specifications. Refer to machine manufacturer's documentation for torque values.
14. Connect wire lines, hydraulic, pneumatic and electrical components, as required.
15. Remove the latches.
16. Set the mold-opening sequence mechanism.

Section 7 - Electrical Testing



WARNING - READ MANUAL

Read Section 3 - Safety on page 3-1 before doing electrical testing. .

This section contains guidelines for electrical testing of your Mold-Masters Hot Runner system. The testing is based on the following European and North American standards:

- EN 60204-1 / DIN EN 60204-1 (IEC 60204-1, modified) Safety of machinery - electrical equipment of machines
- NFPA 79 Electrical Standard for Industrial Machinery

The standards themselves are the final authority for testing requirements (also any additional testing requirements from any national standards where the Hot Runner is in use).

7.1 Safety

The user is responsible to ensure protection against shock by indirect contact, by protective earth conductors and automatic disconnection of supply. Mold-Masters components and systems are either equipped with a protective earth conductor or there is a connector for this purpose.

Ensure that all wiring and connection work is performed by a qualified electrician according to DIN EN 60204-1 / NFPA79.



WARNING - ELECTRICAL HAZARD

Before you carry out electrical work, make sure that the Hot Runner system is securely grounded. Turn the temperature control off and disconnect all electric wires coming from the mold.

If performing work on a disassembled nozzle, the nozzle should only be connected to an electrical supply when the nozzle has been grounded or a safety isolating transformer is used.

Failure to do so may lead to serious injury or death.



WARNING - BURN HAZARD

Contact with a disassembled, heated, nozzle would cause serious burns. Use a sign in a visible location indicating "Danger: Do Not Touch". Wear protective heat-resistant gloves and a full face shield over safety glasses.

7.2 Doing a Check of the Electrical Wiring



WARNING - ELECTRICAL HAZARD

Electrical mains should only be connected to the injection mold when all electrical connections are grounded and the mold is closed. Failure to do so may result in serious injury or death.

1. Check that each wire and thermocouple has a zone number.
2. Check that wires are organized and taped together by zone and plug.
3. Check all wires are secured in wire channels.
4. Connect all power leads and thermocouple wires to mold plugs.

7.3 Electrical Safety Testing



WARNING

Electrical safety tests must be performed according to DIN EN 60204-1, paragraph 18, and NFPA79. Testing guidelines are given in the following; however, the standards identified earlier in the introduction are the final authority.

7.3.1 Doing a Check of Equipment

Make sure that the electrical equipment complies with its technical documentation.

7.3.2 Doing a Test of the Insulation Resistance

Measure the insulation resistance between each pin of the Mold-Masters power connector, in particular the heating circuit and ground.

The insulation resistance is measured at 500 V_{DC}. The insulation resistance must not be less than 1 MΩ.

If this value is not reached when heating, the cause is often moisture inside the heating element, which should be removed using a control unit equipped with this function.

Where a mold has not been in use for several weeks or months, it should be retested.

7.3.3 Doing a Test of the Conditions for Protection by Automatic Disconnection of the Power Supply



WARNING

Take protective measures against shock by indirect contact while performing the following tests.

The conditions for automatic shutdown of the supply is set at Mold-Masters and is usually set such that the protective conductor resistance between the grounding conductor connection and all of the protective earth conductor connected parts, is Maximum 0.3 Ω .

In TN systems the following two checks must be made:

7.3.4 Doing a Test of the Continuity of the Protective Bonding Circuit

Verifies the continuity of the protective bonding circuit. The purpose of this test is to check whether all relevant touchable conductive parts are properly grounded. See the relevant requirements of the standard DIN EN 60204-1 / NFPA79.

The protective conductor resistance is measured with a special instrument with a current between at least 0.2 A and approximately 10 A derived from an electrically separated supply source (for example SELV, see 413.1 of IEC 60364-4-41) having a maximum no-load voltage of 24 V AC or DC. The resistance must be within the expected range.

7.3.5 Doing a Test of the Impedance of the Fault Loop

Fault loop impedance verification and suitability of the associated overcurrent protective device.

The power supply connections and incoming external grounding connections to the Hot Runner system must be verified by inspection (usually through a temperature control device).

The conditions for protection by automatic disconnection of supply must be checked by both:

- Checking the impedance of the fault loop by calculation or measurement.
- Confirming that the setting and characteristics of the associated overcurrent protective device are in accordance with the requirements of the standard.

For more information, see the text of the EN 60204-1/ NFPA79 standards must be verified by inspection.

7.3.6 Doing a Test of the Continuity of a Thermocouple

1. Measure the resistance between each pair of thermocouple wires on the mold's thermocouple connector. The resistance should be between 2.5 Ω and 25 Ω. See Figure 7-1.
2. To verify alignment of thermocouple in the heating element, turn on one zone after the other and check that the temperature responds accordingly if the set temperature is adjusted.

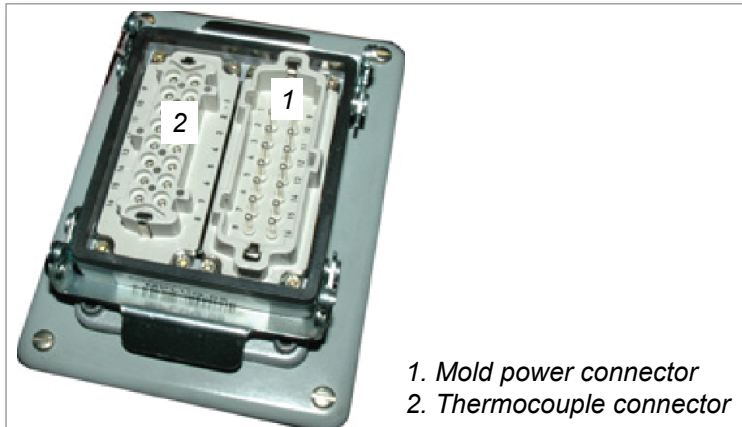


Figure 7-1 Mold plug

7.3.7 Doing a Pinch Point Test

1. If there is a suspected pinch point on the thermocouple, remove the thermocouple from the Hot Runner.
2. Connect a temperature control device to read the temperature.
3. Immerse the sheath of the thermocouple in boiling water to the point where the thermocouple reads the temperature.

A good thermocouple will show a temperature rise as soon as the tip of the thermocouple is immersed in water.

If there is a pinch point in the thermocouple there will be no change in the reading until the pinch point on the thermocouple is immersed in water.

7.3.8 Doing a Check of the Heating Element

Measure the resistance between each pair of heater power wires at the mold power connector.

Compare your reading with your general assembly drawing.

Where:

$$R = \frac{V^2}{P}$$

R = resistance **V** = voltage **P** = power

7.3.9 Doing a Test of the Continuity of the Ungrounded Thermocouple

With an ungrounded thermocouple, there is no circuit or Ohms reading to ground, unless the thermocouple is damaged or pinched. This allows for an Ohms resistance (non-voltage) check prior to and after installation. To do this test, do these steps:

1. Set up a multimeter to read Ohms resistance.
2. Connect one lead to the red thermocouple wire.
3. Connect the other lead to the mold plate that the hot runner system is installed in.
4. If you see an Ohms resistance, replace the thermocouple (faulty thermocouple).
5. Repeat steps 2–4 for the white thermocouple wire.

Do this test on all thermocouples.

7.4 Thermocouple Wiring Guidelines



CAUTION

Exceeding the controller zone amperage will destroy the controller fuses and disconnect power from the controller.

- Thermocouples are Type “J” ungrounded and color coded to ASA standards. (White “+”/ Red “-”).
- The tip must not be truncated or squeezed and must touch the bottom of the bore in order to measure the correct temperature.
- Each heat source should have its own closed loop temperature control in order to achieve accurate control.
- If there are not enough control zones, heat sources that have the same wattage and affect the same environment, may be grouped together.

7.5 Doing a Functional Test with a Temperature Controller



CAUTION

Never start the heating at more than 40% power. Failure to do so may damage equipment.

The functions of the electrical equipment must be checked. This test is carried out with an appropriate temperature control device.

- Monitor the initial heating of the system to minimize risk.
- Stay a minimum of 5 minutes at 100°C (212°F) before increasing heat.

7.6 Retesting

Where a portion of the electrical equipment is changed or modified, that portion must be reverified and retested, as appropriate.

Section 8 - System Startup and Shutdown



WARNING - READ MANUAL

Read Section 3 - Safety on page 3-1 before assembling the Hot Half.

8.1 Pre-Startup

When running thermally sensitive materials, use a thermally stable material as recommended by the material supplier for the initial startup.



WARNING

Assume that the system is pressurized and hot at all times. Take appropriate safety precautions. Failure to do so may result in serious injury or death.



CAUTION

Actuator water temperature must not exceed 29.4 °C (85°F). Water must be turned on for Hot Runner actuation before turning on temperature controls.



CAUTION

The maximum operating temperature for Hot Runner systems is 400°C (750°F).

1. After the Hot Runner system is installed in the molding machine, bleed all the air out of the hydraulic lines, if applicable.
2. Install the mold into the molding machine.
3. Make sure that the machine nozzle opening is the same size as, or is not more than 1.0 mm (0.040 in.) smaller than, the back plate bore.
4. Connect all water lines and test to ensure there are no leaks and that the required flow is achieved in all water circuits.
5. Connect all hydraulic / pneumatic lines, if applicable.
6. Connect all electrical components and monitor to ensure that all zones are receiving heat and all thermocouples are reacting appropriately.
7. Make sure that the system is heated to processing temperature.
8. Optional: Test the valve pin actuation.

8.2 Startup



WARNING

When the mold is open, never inject material through the Hot Runner system under high pressure. Failure to obey can cause serious injury or death.

The correct startup procedure for your Hot Runner system depends on the type of system:

- Standard systems: see 8.2.1 Standard Hot Runner Systems on page 8-2
- Stack mold systems: see 8.3.2 Stack Mold Systems on page 8-5
- Melt Disk systems: see 8.2.3 Melt-Disk on page 8-3 or 8.2.3.2 Reverse Melt-Link on page 8-4.
- Melt Cube systems: see 8.2.4 Melt Cube on page 8-4

8.2.1 Standard Hot Runner Systems



CAUTION

Failure to do the following procedure may result in leaks/damage occurring in the Hot Runner.

For the initial startup, when running thermally sensitive materials, use a thermally stable material as recommended by the material supplier.

1. Turn on the machine barrel and mold cooling system.
2. Prior to start up, ensure the:
 - a) Machine barrel is up to processing temperature.
 - b) Mold cooling is on and at cooling temperature.
3. Heat up all Hot Runner manifolds and/or bridges and inlets (excluding the nozzles) to processing temperature.
4. Begin nozzle heating when the manifolds and/or bridges have come within 50°C of processing temperature. Wait until all heating zones have reached processing temperature for five minutes before continuing. For Hot Runner systems using heater plates, allow ten minutes of soak time after the system reaches processing temperature.
5. Startup the system.
 - a) For empty systems or where there is no material in the gate detail, extrude material through the Hot Runner system using 34.4 bar (500 PSI) of back pressure. The purpose is to fill the Visco-Seal at low pressure. This prevents any possibility of leaks past the nozzle seal.
 - b) For systems filled with material, purge intended shot size twice from the barrel prior to bringing the machine barrel forward to the Hot Runner interface.
6. Set injection time and pressure according to part size, gate size and material.

8.2.2 Stack Mold Systems



CAUTION

Failure to do the following procedure may result in leaks/damage occurring in the Hot Runner.

For the initial startup, when running thermally sensitive materials, use a thermally stable material as recommended by the material supplier.

1. Heat up all Hot Runner manifolds, submanifolds, bridges, sub-bridges, and inlets (excluding the nozzles) to processing temperature.
2. After manifolds, submanifolds, bridges and sub-bridges reach setpoint, heat nozzles and spacers to 150°C (300°F).
3. Heat soak for 15 minutes.
4. Raise nozzle temperature to setpoint.
5. Heat soak for 20 minutes.

8.2.3 Melt-Disk



CAUTION

Failure to follow the correct procedure could result in damage occurring in the Hot Runner.

For systems with a standard Melt Link, see 8.3.4 Melt-Cube on page 8-6.

For systems with a Reverse Melt Link, see 8.2.3.2 Reverse Melt-Link on page 8-4.

See also your controller user manual.

8.2.3.1 Melt-Link



WARNING

When the mold is open, never inject material through the Hot Runner system under high pressure. Failure to obey so can result in serious injury or death.



CAUTION

Failure to do the following procedure may result in leaks or damage occurring in the Hot Runner.

For the initial startup, when running thermally sensitive materials, use a thermally stable material as recommended by the material supplier.

1. Turn on the machine barrel and mold cooling system.
2. Prior to start up, ensure the:
 - a) Machine barrel is up to processing temperature.
 - b) Mold cooling is on and at cooling temperature.
3. Heat manifold zones and inlets to processing temperature.
4. Heat Melt-Disks to processing temperature.

IMPORTANT

Set the Melt-Disk temperature at least 6°C (10°F) lower than the temperature of the nozzles.

5. Heat nozzles to processing temperature.
A small amount of material may weep at this stage.
6. Heat soak for a minimum of 10 minutes.
7. Fill the system under low pressure extrude using screw rotation.

8.2.3.2 Reverse Melt-Link

**WARNING**

Never inject material through Hot Runner system under high pressure when the mold is open. Failure to obey can result in serious injury or death.

**CAUTION**

Failure to do the following procedure may result in leaks or damage occurring in the Hot Runner.

Please see 5.24.1 Identifying a Reverse Melt-Link for more information on how to identify if your system has a Reverse Melt Link.

When running thermally sensitive materials, use a thermally stable material as recommended by the material supplier for the initial startup.

1. Turn on the machine barrel and mold cooling system.
2. Prior to start up, ensure the:
 - a) Machine barrel is up to processing temperature.
 - b) Mold cooling is on and at cooling temperature.
3. Heat manifold zones and inlets to processing temperature.
4. Heat nozzles to processing temperature.
A small amount of material may weep at this stage.
5. Set the nozzle temperatures at least 6°C (10°F) lower than the temperature of the Melt-Disks.
6. Heat Melt-Disks to processing temperature.
7. Heat soak for a minimum of 10 minutes.
8. Fill the system under low pressure extrude using screw rotation.

8.2.4 Melt Cube

**CAUTION**

Failure to do the following procedure may result in leaks or damage occurring in the Hot Runner.

When running thermally sensitive materials, use a thermally stable material as recommended by the material supplier for the initial startup.

1. Heat the bridge and inlet to the processing temperature.
2. Heat the nozzles to the set-point temperature.
3. Wait 10 minutes.
4. The nozzle temperature must be set 6°C (10°F) lower than the Melt-Cube temperature.
5. Heat the Melt-Cube to the processing temperature.
6. Heat soak for a minimum of 5 minutes.
7. Fill the system under low pressure extrude using screw rotation.

8.3 Shutdown

8.3.1 Standard Hot Runner Systems



CAUTION

Failure to do the following procedure may result in leaks/damage occurring in the Hot Runner.

IMPORTANT

Thermally sensitive materials should be purged from the Hot Runner system prior to shutdown using a thermally stable material with a similar processing temperature.

1. Turn off all heat to the system.
2. Leave the mold cooling system turned on until the Hot Runner system temperature is within 55°C (130°F) of the mold temperature.

8.3.2 Stack Mold Systems



CAUTION

Failure to do the following procedure may result in leaks/damage occurring in the Hot Runner.

IMPORTANT

Thermally sensitive materials should be purged from the Hot Runner system prior to shutdown using a thermally stable material with a similar processing temperature.

1. Shutdown spacers, bridges and sub-bridges.
2. Reduce nozzle temperatures to 230°F (110°C).
3. Wait 20 minutes.
4. Shutdown manifolds, submanifolds, inlets and nozzles.

8.3.3 Melt-Disk



CAUTION

Failure to follow the correct procedure could result in damage occurring in the Hot Runner.

For systems with a standard Melt Link, see 4. Shutdown manifolds, submanifolds, inlets and nozzles. on page 8-5.

For systems with a Reverse Melt Link, see:8.3.3.2 Reverse Melt Link on page 8-6.

See also your controller user manual.

8.3.3.1 Melt Link



CAUTION

Failure to do the following procedure may result in leaks or damage occurring in the Hot Runner.

Thermally sensitive materials should be purged from the Hot Runner system prior to shutdown using a thermally stable material with a similar processing temperature.

Maximize decompression stroke prior to shutdown. Doing so will minimize drool at startup when there is limited gate cooling.

1. Reduce nozzle temperatures to 150°C (300°F).
2. Reduce Melt-Disk temperatures to 150°C (300°F).
3. Turn off all zones.

8.3.3.2 Reverse Melt Link



CAUTION

Failure to do the following procedure may result in leaks or damage occurring in the Hot Runner.

Thermally sensitive materials should be purged from the Hot Runner system prior to shutdown using a thermally stable material with a similar processing temperature.

Maximize the decompression stroke prior to shutdown. Doing so will minimize drool at startup when there is limited gate cooling.

See 5.24.1 Identifying a Reverse Melt-Link on page 5-108 for more information on how to identify if your system has a Reverse Melt Link.

1. Reduce Melt-Disk temperatures to 150°C (300°F).
2. Reduce nozzle temperatures to 150°C (300°F).
3. Turn off all zones.

8.3.4 Melt-Cube



WARNING

When the mold is open, never inject material through the Hot Runner system under high pressure. Failure to obey can result in serious injury or death.



NOTE

The startup and shutdown procedures for Melt-Cube design A and Melt-Cube design B are identical.



CAUTION

Failure to do the following procedure may result in leaks or damage occurring in the Hot Runner.

Thermally sensitive materials should be purged from the Hot Runner system prior to shutdown using a thermally stable material with a similar processing temperature.

1. Reduce the Melt-Cube system temperature to 150°C (300°F).
2. Reduce the nozzle temperature to 150°C (300°F).
3. Turn off all zones.

Section 9 - Color Change



WARNING

Make sure that you have fully read Section 3 - Safety before purging the Hot Runner system.

Although it is not possible to make a generic color change procedure that will give the best performance in all circumstances because the flow characteristics of the plastic polymers in use can influence color changes, there are specific procedures which work to enhance color changes.

9.1 General Tips

- Always process a natural / clear color for the first shot on an empty Hot Runner system to coat the melt channel walls and gate bubbles with a neutral color.
- Ensure the hopper and conveying system are free of all contamination from the previous production color. Many times the previous color will hang up in the hopper or conveying system and be slowly released into the mold resulting in contaminated parts. Also, make sure there is no contamination in the resin being used in production.
- Schedule color changes from light to progressively darker.
- Understand the economics of your color change to decide if it is economically better to take the time to latch over the cavity plate and clean out the gate bubbles or just run scrap parts slightly longer to clean out the gate bubble area.
- Use purge compounds for color change in the machine barrel and Hot Runner.

9.2 Procedure A: Simple and Effective



WARNING

Wear a protective heat-resistant coat, heat-resistant gloves, and a full face shield over safety glasses.

Use adequate ventilation for fumes. Some plastics develop gases that may be dangerous to personal health. Follow the plastics supplier's recommendations.

Do not look directly into the feed throat of a hopper; use a mirror. An unexpected release of resin may cause serious burns.

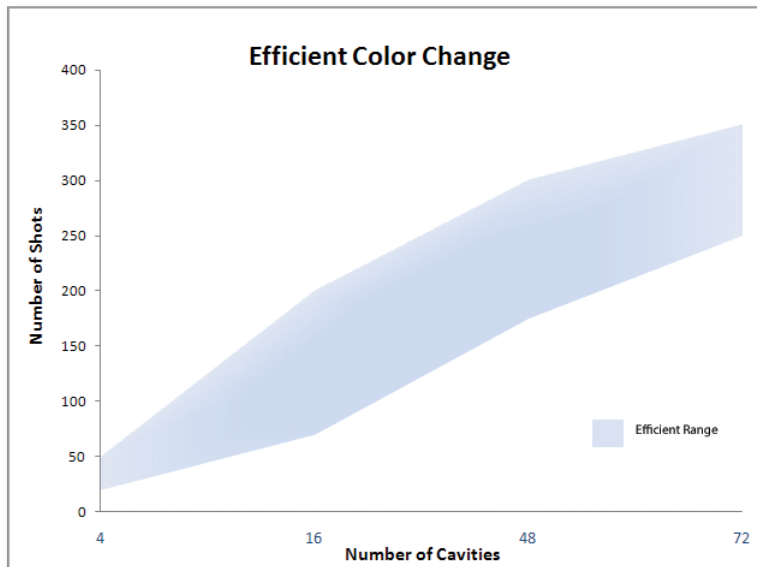
Never handle plastic purgings or drool until they have completely cooled. Purgings may appear solid but may still be hot and cause serious injury.

1. Empty the hopper of existing color and clean thoroughly.
2. Increase the Hot Runner system temperature of all zones to 20°C (68°F) above the processing temperature. On Mold-Masters controllers, simply push the boost button on the controller to increase temperatures for a pre-determined time and temperature.
3. Back off the machine barrel, introduce the appropriate purge compound and purge until previous material is cleaned, then introduce new color. Increase the barrel/extruder heats to help flush the previous color (see the machine maker recommendations).
4. Increase the injection speed to help flush the previous material.
5. Use a Hot Runner purging compound (e.g., *DME's Fresh Start Purging Solutions™ MC-2-HH or GP-HH*) at the recommended temperature to further reduce the color change time.

6. Run parts until the color has been completely flushed.
7. Continue processing while resetting the Hot Runner system temperatures and injection speed back to normal.
8. Return all settings to normal and confirm acceptable part quality.

9.3 Procedure B: Comprehensive

1. Empty hopper of existing color and clean thoroughly.
2. Increase Hot Runner system temperature on all zones 20°C (68°F) above processing temperatures. On Mold-Masters controllers, simply push the boost button to increase temperatures for a pre-determined time and temperature.
3. Back off the machine barrel, introduce the appropriate purge compound and purge until previous material is cleaned, then introduce new color. Increase barrel / extruder heats to help flush previous color (see machine maker recommendations).
4. Increase injection speed to help flush previous material.
5. Use Hot Runner purging compound (e.g. ASACLEAN™, Dyna-Purge®) at recommended temperatures to further reduce color change time.
6. Run 10 - 15 shots with natural material.
7. Back off the injection unit and switch off all heat on the Hot Runner.
8. Allow the Hot Runner system to cool down.
9. Latch over cavity plate.
10. Remove and clean gate bubbles.
11. Latch back cavity plate.
12. Turn on the Hot Runner system and heat to processing temperature.



13. Bring machine barrel back in.
14. Fill the Hot Runner with natural color resin to coat the melt channels with a neutral color (1-2 shots).
15. Introduce the new color.
16. Leave mold in open position and set the shot size to maximum possible.

17. Purge the entire shot through the Hot Runner and out the gates into the exposed cavity at the highest injection rate possible. Repeat this several times.

**NOTE**

Optional: Put a protective shield over the core side to prevent plastic from injecting and cooling on the core side.

18. Set the shot size back to normal levels and begin processing parts with increased injection speeds and mold temperature.
19. Continue processing while resetting Hot Runner system temperatures and injection speed back to normal.
20. Return all settings to normal and confirm acceptable part quality.

Section 10 - Maintenance

**WARNING - READ MANUAL**

Read Section 3 - Safety on page 3-1 before doing maintenance procedures on a Hot Runner System.

This chapter is a guide to maintaining selective components. Repairs that should be performed by Mold-Masters personnel are not included. If you need an item repaired that is not included in this section, please call Mold-Masters support. The phone number and system identifier is located on the mold.

10.1 Extraction Puller Overview

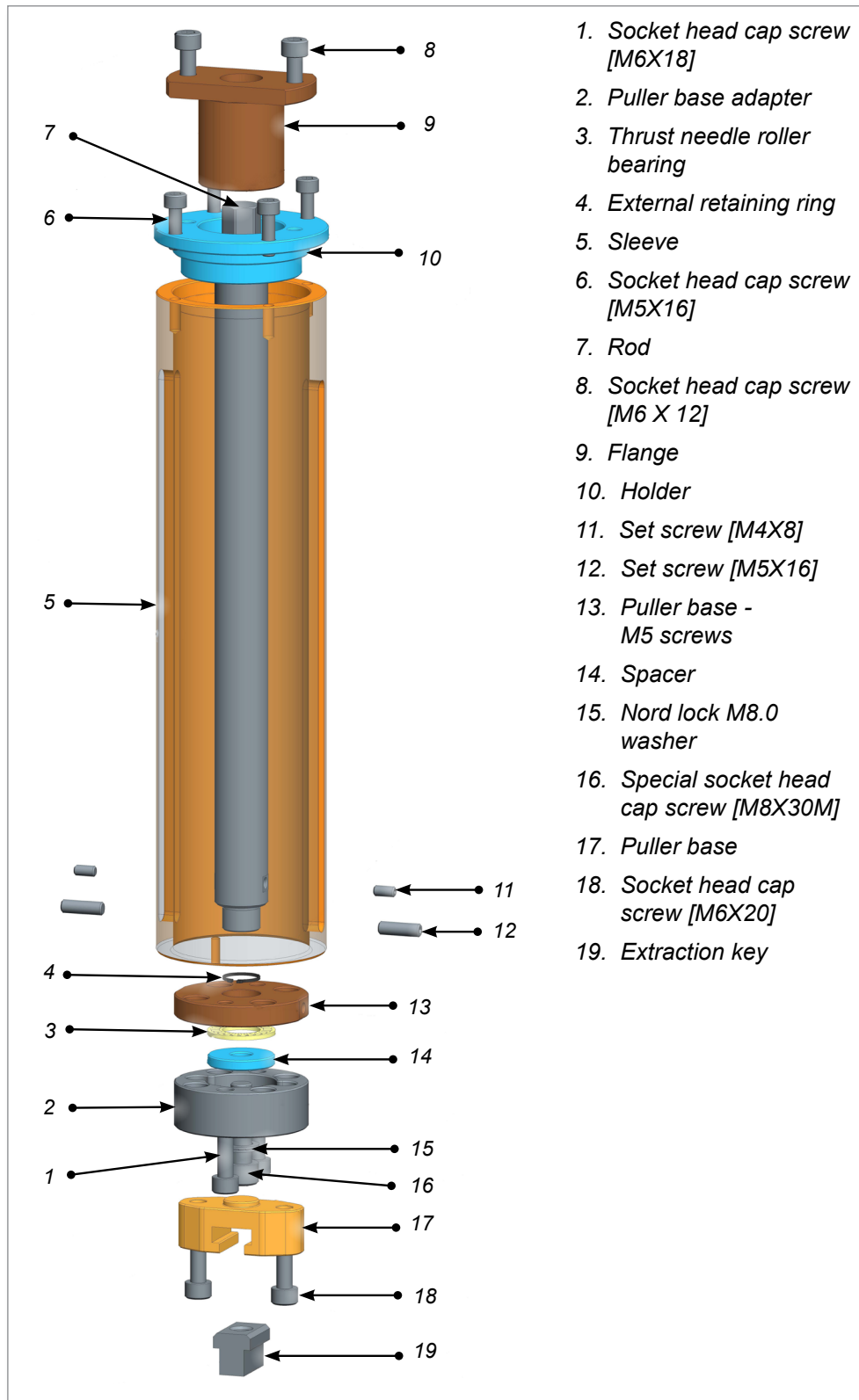


Figure 10-1 Extraction puller (EXTOOLAS10)

10.2 Valve Disks

All maintenance on Mold-Masters products should be performed by properly trained personnel based on local law or regulation requirements. Electrical products may not be grounded when removed from the assembled or normal operating condition. Assure proper grounding of all electrical products before performing any maintenance to avoid potential risk of electrical shock.



WARNING

To avoid serious burns, wear safety clothing consisting of a protective heat resistant coat and heat-resistant gloves. Failure to do so can result in serious injury.



WARNING

Use adequate ventilation for fumes. Failure to do so can result in serious injury.



CAUTION

Never heat up the system without first clamping the main manifold, especially if the nozzles are not secured with the Hot Half. Check that the manifold is secure. For cast-in systems, secure the manifold with clamps to prevent movement.

10.2.1 Removing a One-Piece Valve Disk

Table 10-1 Extraction Tool Parts					
Assembly	A	B	C	D	Description
EXTOOL28	EXTOOL28A	EXTOOL28B	EXTOOLPIN01	SPACER86 Can be used without, if space permits	For VD's with 35 mm OD's
EXTOOL29	EXTOOL29A	EXTOOL29B			For VD's with 39 mm OD's
EXTOOL30	EXTOOL30A	EXTOOL30B			For VD's with 42 mm OD's
EXTOOL31	EXTOOL31A	EXTOOL31B		SPACER87	For VD's with 49 mm OD's
EXTOOL52	EXTOOL52A	EXTOOL28B		SPACER86 Can be used without, if space permits	Valve disk (Ø31) extraction tool assembly

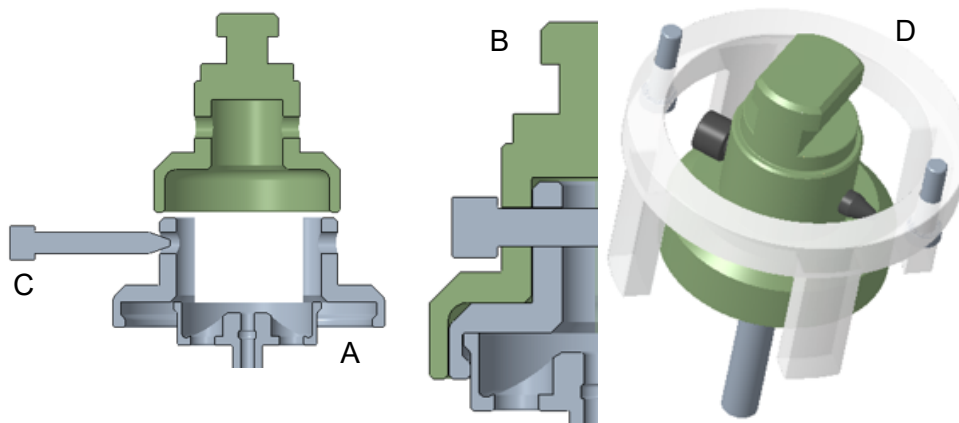
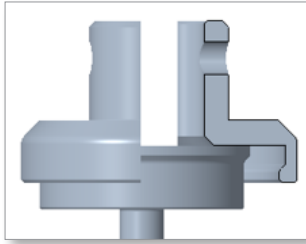


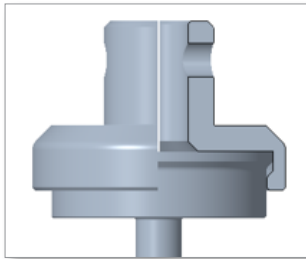
Figure 10-2 Overview of the extraction adapter for the 1-piece valve disk

1. Heat the manifold to soften any plastic still in the system.

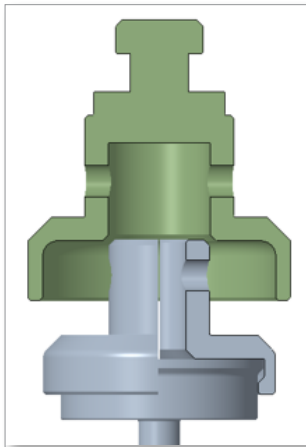
2. Attach the half clamps (A) to the valve disk.



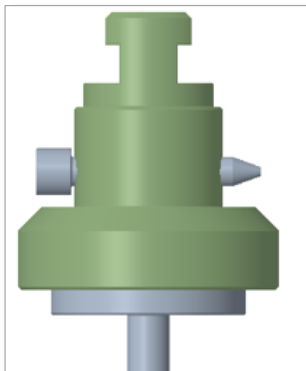
3. Shift the half clamps toward the center to lock on to the valve disk.



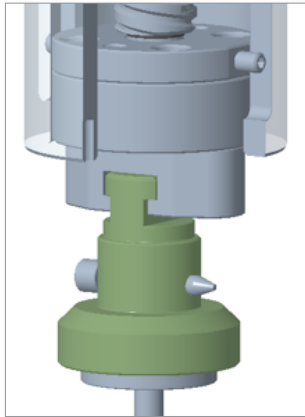
4. Install the holder (B) on to the half clamps



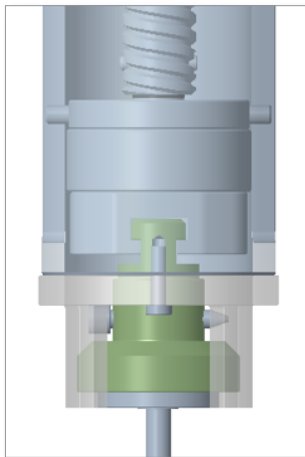
5. Insert the quick release pin (C) to lock the half clamps and holder together.



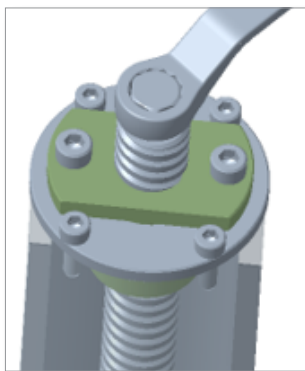
- Slide the valve-disk-extraction adaptor into the extraction puller (see section 10.1 Extraction Puller Overview on page 10-2 for more information on the extraction puller) .



- Optional: Install the spacer (D).



- Use a 13 mm (1/2") wrench or power tool to unscrew the bolt and extract the valve disk from the manifold. Make sure that the pulling direction is perpendicular to the manifold surface.



10.2.2 Removing a One-Piece Valve Disk (Close pitch)

Table 10-2 Extraction Tool Parts					
Assembly	A	B	C	D	Description
EXTOOL53	EXTOOL53A	EXTOOL54B	EXTOOLPIN01	SPACER217 with SPACER218 (4)	For VDs with 31 mm ODs
EXTOOL54	EXTOOL54A	EXTOOL54B		SPACER217 with SPACER218 (4)	For VDs with 35 mm ODs
EXTOOL55	EXTOOL55A	EXTOOL55B		SPACER217 with SPACER218 (4)	For VDs with 39 mm ODs
EXTOOL56	EXTOOL30A	EXTOOL30B		SPACER217 with SPACER218 (4)	For VDs with 42 mm ODs
EXTOOL57	EXTOOL31A	EXTOOL31B		SPACER217 with SPACER218 (8)	For VDs with 49 mm ODs

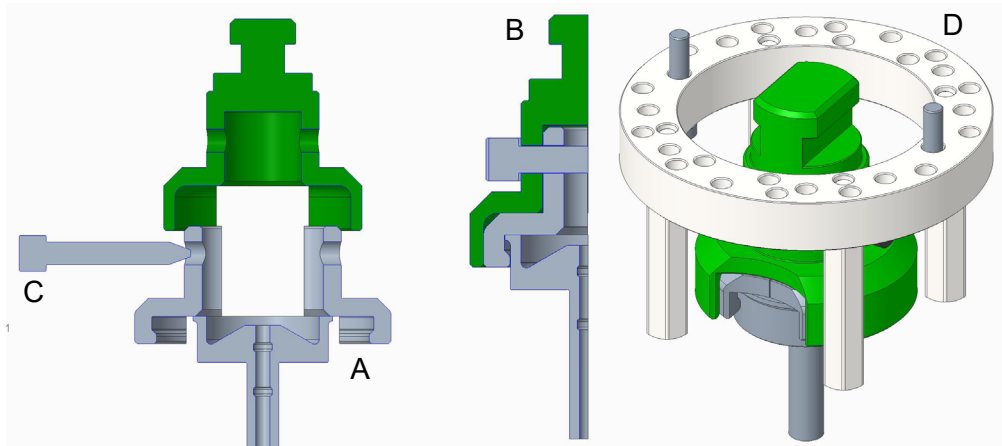
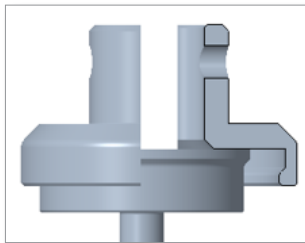
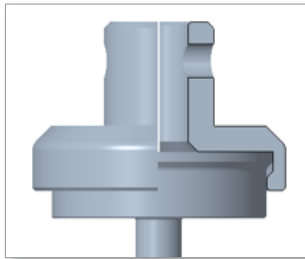


Figure 10-3 Overview of the extraction adapter for the one-piece valve disk

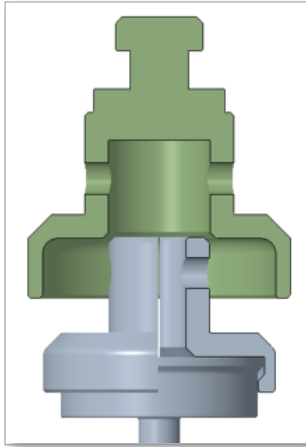
1. Heat the manifold to soften any plastic still in the system.
2. Attach the half clamps (A) to the valve disk.



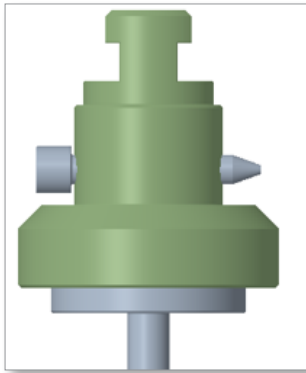
3. Shift the half clamps toward the center to lock on to the valve disk.



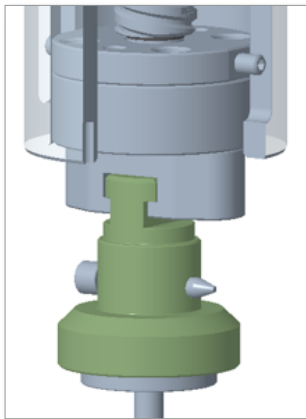
4. Install the holder (B) onto the half clamps



5. Insert the quick release pin (C) to lock the half clamps and holder together.

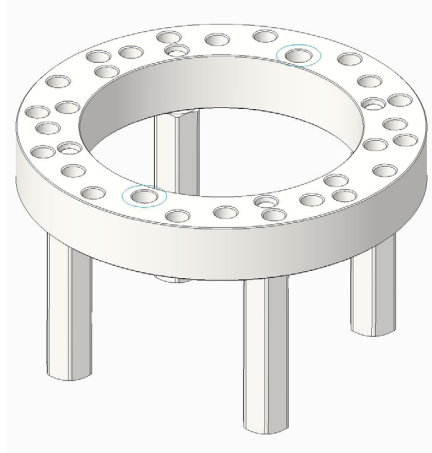
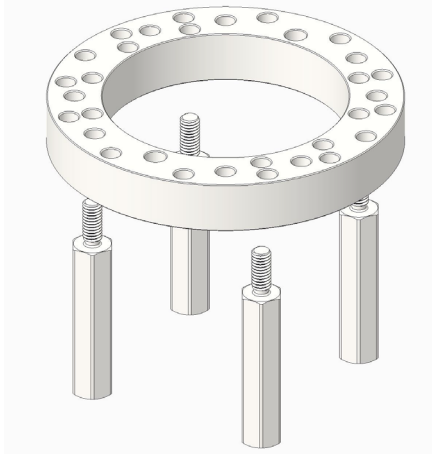


6. Slide the valve-disk-extraction adaptor into the extraction puller (see section 10.1 Extraction Puller Overview on page 10-2 for information on the extraction puller) .

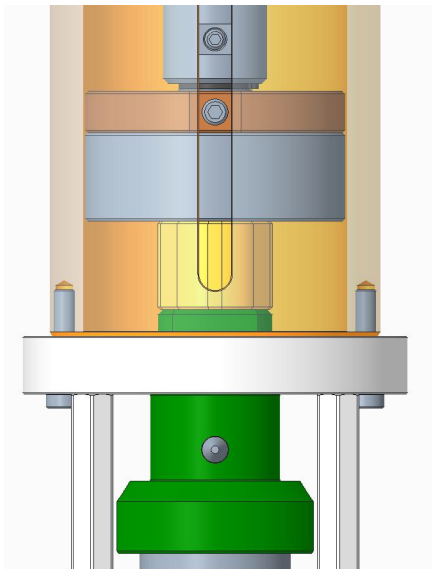
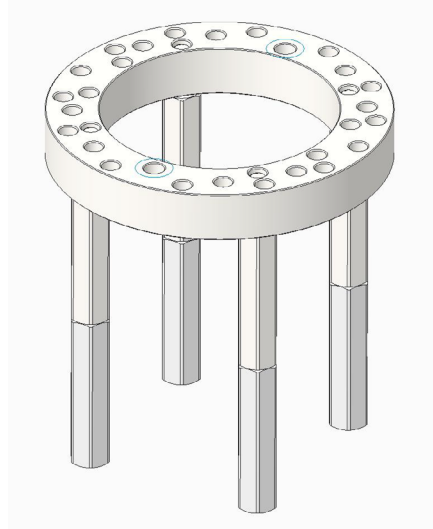
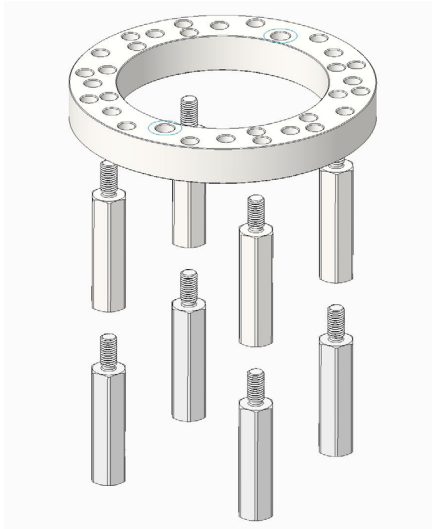


7. Optional: Install the spacer (D).

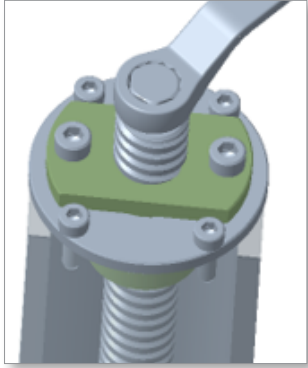
One-level spacer:



Two-level spacer:



8. Use a 13 mm (1/2") wrench or power tool to unscrew the bolt and extract the valve disk from the manifold. Make sure that the pulling direction is perpendicular to the manifold surface.



10.2.3 Removing a Two-Piece Valve Disk (Thread extraction)

Table 10-3 Extraction Tool Parts			
A	Used With	B	C
EXTOOL41	VDSTEM048* (FEMTO) VDSTEM052* (FEMTO) VDSTEM060*/65* (FEMTO) VDSTEM049* (PICO) VDSTEM053* (PICO) VDSTEM050* (CENTI) VDSTEM054* (CENTI)	SPACER86	LHCSM4X16
EXTOOL42	VDSTEM051* (DECI) VDSTEM055* (DECI)		
EXTOOL43	VDSTEM056*-59* (HECTO) VDSTEM061*-64* (HECTO)		

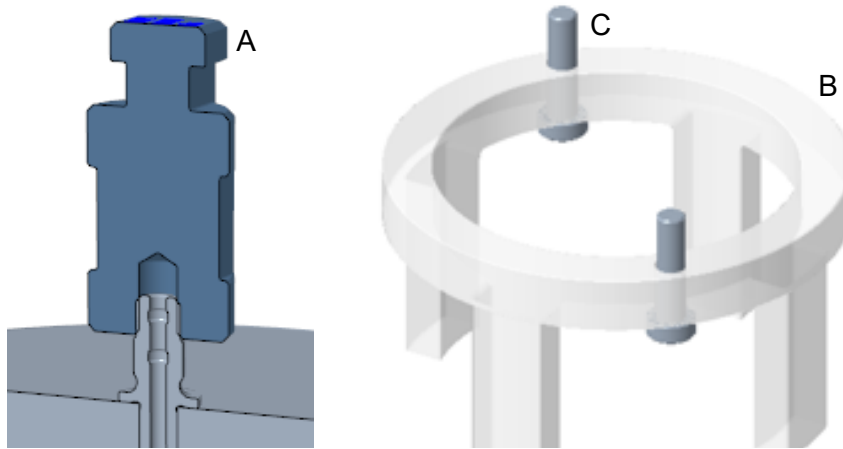
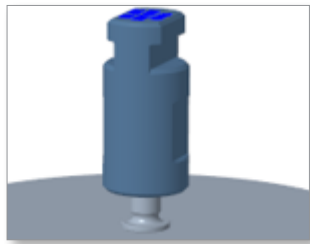
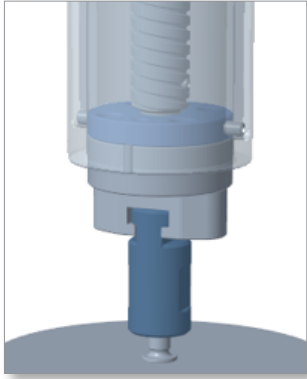


Figure 10-4 Overview of the extraction adapter for the 2-piece valve disk (Thread extraction)

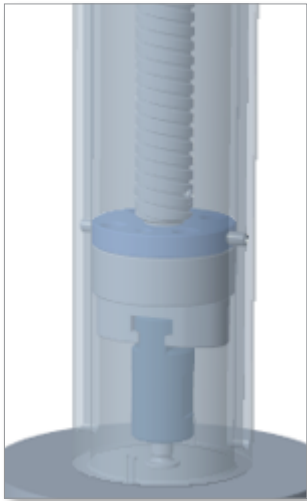
1. Heat the manifold to allow any plastic still in the system to become soft.
2. Attach the valve-disk (VD) extraction adapter (A) to the VD stem.



3. Slide the extraction puller (see section 10.1 Extraction Puller Overview on page 10-2) onto the extraction adapter, and make sure they are aligned.



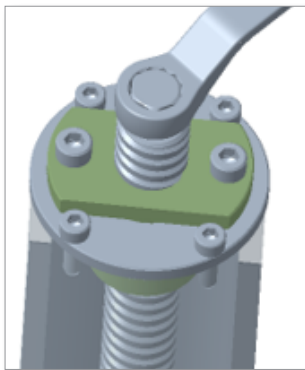
4. If there is a sufficient gap between the drops, use the extraction puller without a spacer to extract the VD stem.



5. For close pitch conditions, use a spacer (B and C) with the extraction puller.



6. Use a 13 mm (1/2") wrench or power tool to unscrew the bolt and extract the valve disk from the manifold. Make sure that the pulling direction is perpendicular to the manifold surface.



10.2.4 Removing a Two-Piece Valve Disk (Groove extraction)

Table 10-4 Extraction Tool Parts					
Assembly	Used With	A	B	C	D
EXTOOL35AP	VDSTEM048* (FEMTO) VDSTEM052* (FEMTO) VDSTEM060*/ 65* (FEMTO) VDSTEM049* (PICO) VDSTEM053* (PICO) VDSTEM50* (CENTI) VDSTEM54* (CENTI)	EXTOOL35-A	EXRING09	EXKEY012	BHCSM4X8
EXTOOL36AP	VDSTEM051* (DECI) VDSTEM055* (DECI)	EXTOOL36-A	EXRING10	EXKEY012	BHCSM4X8
EXTOOL37AP	VDSTEM056* -59* (HECTO) VDSTEM061* -64* (HECTO) VDSTEM081 (HECTO)	EXTOOL37-A	EXRING11	EXKEY012	BHCSM4X8
EXTOOL38AP	VDSTEM078*-80* (MEGA) VDSTEM082*-84* (MEGA)	EXTOOL38-A	EXRING14	EXKEY012	BHCSM4X10

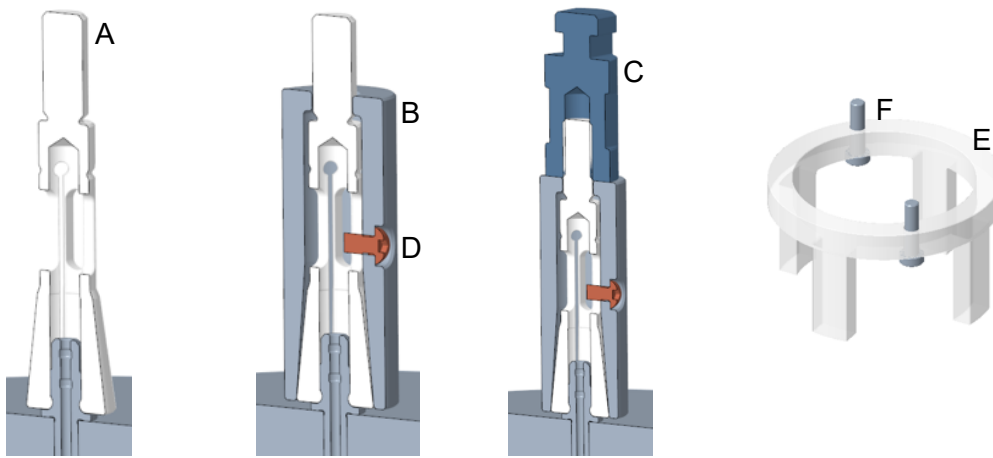


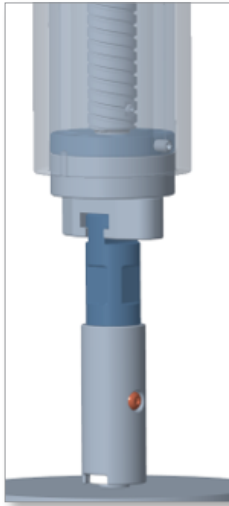
Figure 10-5 Overview of the extraction adapter for the two-piece valve disk (Groove extraction)

E = SPACER86

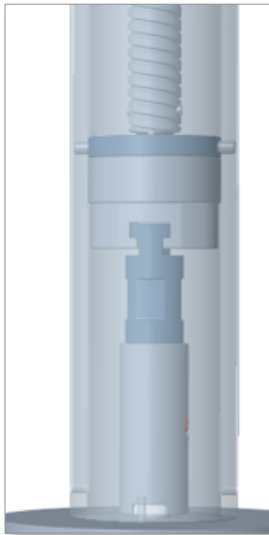
F = LHCSM4X16

1. Heat the manifold to allow any plastic still in the system to become soft.
2. Install A until it catches the VD stem groove.
3. Install B.
4. Use the screw (D) to fasten the parts together.
5. Screw on the extraction key (C).

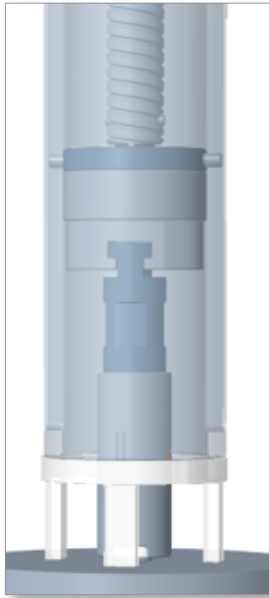
- Slide the extraction puller (see section 10.1 Extraction Puller Overview on page 10-2) onto the extraction adapter, and make sure they are aligned.



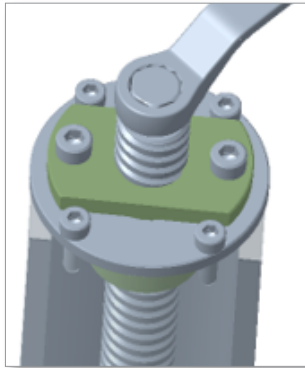
- If there is a sufficient gap between the drops, use the extraction puller without a spacer to extract the VD stem.



8. For close pitch conditions, use a spacer (E and F) with the extraction puller to extract the VD stem.



9. Use a 13 mm (1/2") wrench or power tool to unscrew the bolt and extract the valve disk from the manifold. Make sure that the pulling direction is perpendicular to the manifold surface.



10.3 Terminal Ends

Although the following procedure shows a nozzle terminal end, the process is the same for manifold terminal ends.

10.3.1 Removing



CAUTION

When removing the element sleeve, be careful to avoid damaging the ceramic sleeve and terminal nut.

1. If the terminal end is covered with plastic, warm the terminal end prior to removing the element sleeve.

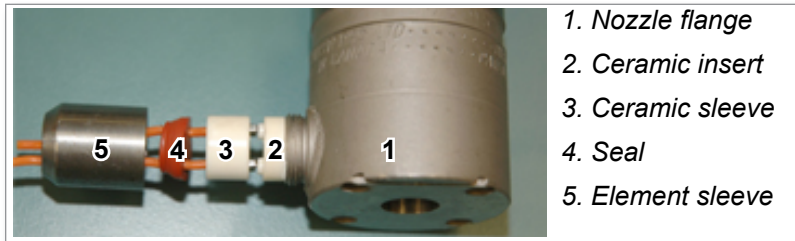


Figure 10-6 Nozzle terminal assembly

2. Grip the element sleeve at the threaded area and turn counter clockwise. If the wires rotate with the sleeve, damage may result.
3. Remove the seal.
4. Remove the set screw from the ceramic sleeve.
5. Remove the power leads.

10.3.2 Installing

Please contact Mold-Masters to ensure you have the correct repair kit and crimping tool. The tools, along with the lead wire replacement kit, are available through the Mold-Masters MasterCare.

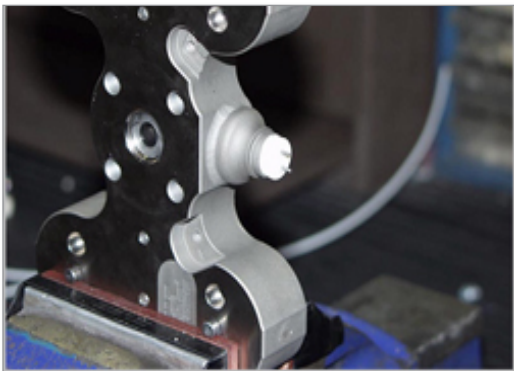
Although the following procedure shows a manifold, the process is the same for nozzle terminal ends.

10.3.3 Assembling a Terminal End

1. Assemble the repair kit components.



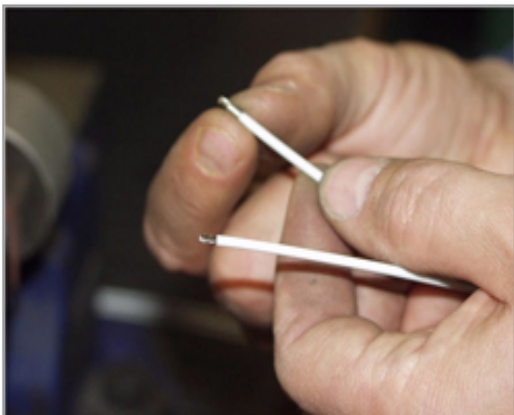
2. Ensure the terminal end is clean.



3. Slide the element sleeve, silicon seal and ceramic insulator onto the wires.



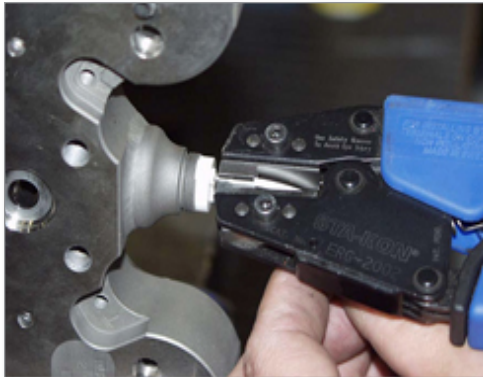
4. Slide crimps onto leads. Stranded wire should extend beyond the crimp.



5. Spread the wire strands and insert the lead wire onto the terminal posts.



6. Grasp the crimp with the crimping tool, slide the crimp into position over the terminal post and crimp the connection.



7. Slide the ceramic insulator and silicon seal into place.



8. Screw the element sleeve into the position. Make sure that the silicon sleeve does not rotate with the sleeve which may damage the wire.

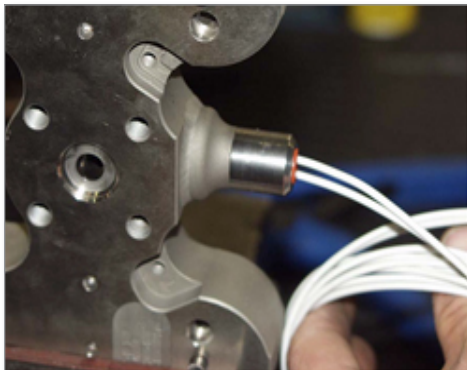


Table 10-5 Crimping Tool Chart	
Product Name	Description
PUNCHHANDLE01	Ratchet tool for securing crimp to terminal end assemblies
CRIMPDIE01	4.0mm Heater Element (Mates with CRIMPPUNCH01)
CRIMPPUNCH01	4.0mm Heater Element (Mates with CRIMPDIE01)
CRIMPDIE02	2.5 - 3.0mm Heater Element (Mates with CRIMPPUNCH02)
CRIMPPUNCH02	2.5 - 3.0mm Heater Element (Mates with CRIMPDIE02)
CRIMPDIE03	1.8 - 2.0mm Heater Element (Mates with CRIMPPUNCH03)
CRIMPPUNCH03	1.8 - 2.0mm Heater Element (Mates with CRIMPDIE03)
CRIMPREMOVEB01	Bottom Crimp Removal Insert for shearing HE crimps (Mates with CRIMPREMOVET01)
CRIMPREMOVET01	Top Crimp Removal Insert for shearing HE crimps (Mates with CRIMPREMOVEB01)

10.4 Heater Plates

10.4.1 Removing a Power Lead

1. Remove the set screws.
2. Slide ceramic sleeve off.
3. Remove the power leads using crimp removal tool.

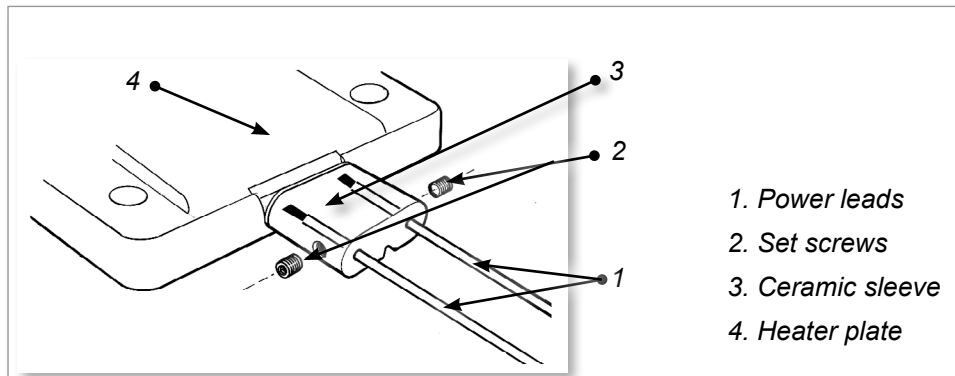


Figure 10-7 Terminal end assembly

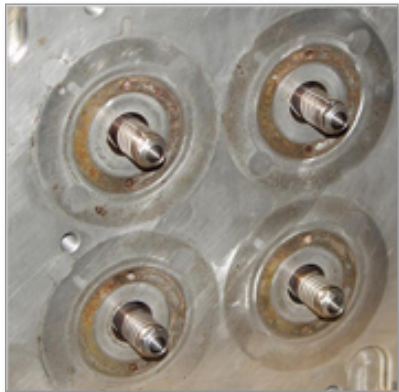
10.4.2 Installing a Power Lead

1. Push the replacement leads into the holes in the ceramic sleeve.
2. Crimp the leads to the terminal ends.
3. Slide ceramic sleeve over the terminal end.
4. Tighten the set screws on the ceramic sleeve to secure the terminal assembly.

10.5 Gate Seals

Reasons for Gate Seal Maintenance

- Tip damage
- Obstruction to melt flow
- Gate seal damage
- Tip wear



10.5.1 Heating the System

It is advisable to heat the system to ensure the temperature condition is met to remove the gate seals.



NOTE

Use the socket supplied in the Mold-Masters tool kit to loosen the gate seal.

It is recommended to use a temperature controller for this procedure. If a temperature controller is not available, contact your nearest Mold-Masters Service Department.

For gate seal installation and torquing procedures refer to “Replacing a Gate Seal” section.

10.5.2 Removing a Gate Seal



WARNING

High temperature on the nozzle. Wear safety clothing such as heat-resistant coat and heat-resistant gloves. Failure to do so may cause serious injury.



CAUTION

Seals and liners for Accu-Valve MX, Accu-Valve EX and Accu-Valve CX are a sub-assembly utilizing a manufactured interference fit. Disassembly of this sub-assembly may affect alignment of the valve pin to the gate, causing wear.

The terminal end is a sensitive area and can easily break if not handled to specifications.



NOTE

If the cavity plate is easily removed you can access the nozzle seals while still in the system.

Hot Runner systems must be within 40°C (104°F) of mold temperature before the cavity plate can be removed. It is recommended the nozzle be removed from the system before removing the gate seal.

Use the socket supplied in the Mold-Masters tool kit to loosen the gate seal.

The following procedure applies to all gate seals (including carbide) with threads larger than an M6 (excluding TIT Edge).

1. Apply penetrating lubricant to gate seal area.



2. Leave the nozzle in the mold or remove it to a vice and clamp carefully.
3. Using the temperature controller, heat the nozzle body until all residual plastic is melted from the gate area. If the nozzle is inside the mold, heat up the whole system and turn on the cooling or remove all O-rings.
4. While the nozzle is still hot, apply a loosening pressure to the gate using the socket to remove the seal.



5. Turn off the controller and wait for five minutes.
6. Remove the gate seals.

10.5.3 Replacing a Gate Seal



WARNING

High temperature nozzles. Ensure that the nozzles have cooled to room temperature. Failure to do so may cause serious injury.

Wear safety clothing such as a heat-resistant coat and heat-resistant gloves. Failure to do so may cause serious injury.



CAUTION

It is critical that seal surface is perfectly clean. Failure to clean properly may result in nozzle and seal damage and leaks.

Any anti-seize compound that enters the internal runner must be removed to prevent contamination of melt.

Failure to torque the gate seals at processing temperatures may result in leaks.

1. Clean the nozzle, especially the thread and runner.
2. Clean all residual plastic from the threads and counter bore of the gate seal.

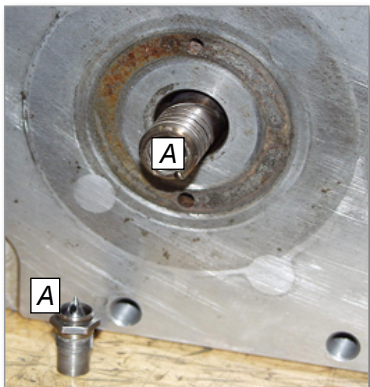


Figure 10-8 (A) Cleaning location

3. Check the bottom face of the nozzle counterbore for damage. If damaged, lap the bottom face of the nozzle in a circular fashion with a hardened tool and 300 grit lapping compound. If the nozzle counterbore is free of damage, proceed to step 5.



4. After lapping is complete, apply die spotting blue compound to the liner to the nozzle to ensure proper mating. If the liner is making good contact, clean the die spotting blue compound off both faces.



5. Apply nickel based anti-seize compound to the gate seal threads ONLY. Make sure that the internal runner is clean and free from anti-seize compound.



6. Using a socket wrench, re-install the gate seal being careful not to damage it.
7. Tighten the gate seal to the appropriate value. Refer to Tighten Settings on page 4-3.
8. Check that the seal has bottomed out, heat nozzle to process temperature and re-torque seal.

10.6 Nozzle Tips

10.6.1 Checking the Height of a Nozzle Tip

1. Correct nozzle tip height and nozzle reference point is found on the gate detail of your general assembly drawing.
2. Assemble spacer blocks to same value as correct nozzle tip height.
3. Zero indicator to spacer blocks.



4. Move indicator to correct reference point on nozzle tip (per drawing).
5. Check that nozzle height is within drawing specification.
6. Repeat for each nozzle.



10.7 Melt-Disk/Melt-Cube

10.7.1 Disassembling a Melt Link / Reverse Melt-Link

IMPORTANT

Before shutting down the molding machine and mold, use maximum screw decompression to remove as much molten plastic from the Hot Runner system as possible.

Plate insertion and removal are to be done with all components in the cold condition.

1. Disassemble the mold to expose the Melt-Disk.
2. Heat the Melt-Disk to 120–138°C (250–280°F).
3. Remove the Melt-Disk as soon as it reaches the setpoint. You can use two M4 screws to help remove the Melt-Disk.

10.7.2 Re-assembling a Melt-Disk/Melt-Cube

1. Inspect all sealing surfaces for defects and clean the sealing surfaces if necessary.
2. Make sure that the inside bore of the Melt-Disk is free of material so that when it is installed in the Melt-Link there is no interference.
3. Install the Melt-Disk cold onto a cold Melt-Link.

10.7.2.1 Re-assembling a Melt-Disk/Melt-Cube with a Reverse Melt-Link

1. Heat the manifold and nozzle to processing temperature.
2. Gently insert the room-temperature male part of the reverse Melt-Link of the Melt-Cube/ Melt-Disk into the female mating part on the nozzle. Make sure that the sharp edge of the male part of the Melt-Link has no plastic residue and is not damaged during assembly. The male part of the Melt-Link should easily move into the heated mating female part and center itself.

10.8 Actuators



WARNING

Extreme heat. Avoid contact with heated surfaces.

Use appropriate protective clothing. Failure to do so can cause serious injury. If possible keep cooling on within Hot Half.

Do not assemble new O-rings if the plates are still hot.
Drain the oil before removing the pin from the hydraulics.



CAUTION

Heat sensitive materials should be purged from the system prior to maintenance. Failure to do so may result in degradation of material in the system.

When heating the Hot Runner system for maintenance, mold cooling should be on to protect seals and O-rings.

For systems with Accu-Valve EX, Accu-Valve MX or Accu-Valve CX gate seals:

Gate seals must be removed prior to removing or re-installing valve pins.

If material is present in the mold, raise nozzle temperature enough to allow removal or installation of the valve pin. However, nozzle temperature should not be high enough to allow excessive material flow from the nozzle into the thread area.

After installing valve pins thoroughly clean the nozzle seat and thread area.

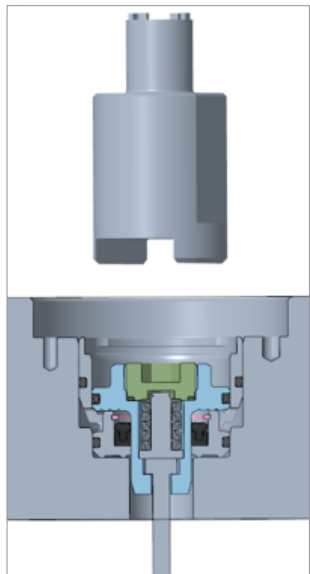
Actuator units should be inspected every 12 months or according to the pre-determined maintenance schedule.

Table 10-6 Actuator Extraction Packages (Uses extraction puller EXTOOLAS10)			
Actuator Series	Extraction Tool Package	Parts	Used to Extract
PN2310x/PN2310xL PN2310xAR/ PN2310xLAR	EXTOOL2300P1	EXTSTUDM6	Piston bottom
		EXTOOL04	Piston top
HY5500x HY550Xx/HY550XxL	EXTOOL5500P1	EXTOOL06	Piston top/bottom
		EXTOOL39A	Cylinder body
HY6500x/HY6500xAR HY650Xx/HY650XxAR HY650XxL/HY650XxLAR HY6600x/HY6600xAR HY6700x/HY6700xAR HY7100x/HY7100xAR HY710Xx/HY710XxAR HY710XxL/HY710XxLAR HY8700x VPAC0008/VPAC0009 VPAC0010/VPAC0011	EXTOOL6500P1	EXTOOL01	Piston top
		EXTOOL32A	Piston bottom
		EXTOOL38A	Cylinder body
HY680SA/HY680SAL	EXTOOL680SAP	EXTOOL33A	Piston bottom
		SPACER88	Supporting parts for extraction
		LHCSM4X16	
		EXTOOL01	Piston top
HY681SA/HY681SAL	EXTOOL681SAP	EXTOOL46A	Piston bottom
		SPACER88	Supporting parts for extraction
		LHCSM4X16	
		EXTOOL47	Piston top
HY8400x HY8500x HY8600xAR HY8800x	EXTOOL8400P1	EXTOOL32A	Piston bottom/ Cylinder-body
		SPACER88	Supporting parts for extraction
		LHCSM4X16	
		RGNR3000-X187	
		EXTOOL01	Piston top
PN6400x/PN6400xAR PN6410x/PN6410xAR	EXTOOL6400P	EXTOOL25	Piston bottom/ Cylinder-body
		SPACER88	Supporting parts for extraction
		LHCSM4X16	
		RGNR3000-X250	
		EXTOOL24	Piston top
PN6400SA	EXTOOL6400SAP	EXTOOL33A	Piston bottom/ Cylinder-body
		SPACER88	Supporting parts for extraction
		LHCSM4X16	
		RGNR3000-X250	
		EXTOOL01	Piston top

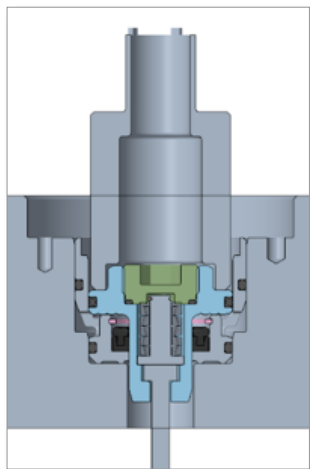
10.8.1 Extracting a Piston Top

10.8.1.1 HY65*, HY66*, HY67*, HY71*, HY87*, VPAC0008/9/10/11, HY680SA/SAL and HY681SA/SAL, HY8400X/85/86AR/88, PN6400X/XAR, PN6410X/XAR, PN6400SA

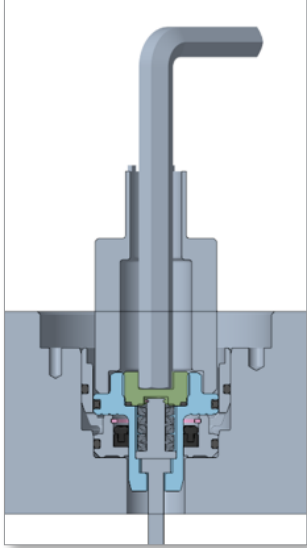
1. Insert the extraction tool in the piston bottom.



2. Align the extraction tool A/F and the piston bottom A/F to prevent the piston bottom from moving.



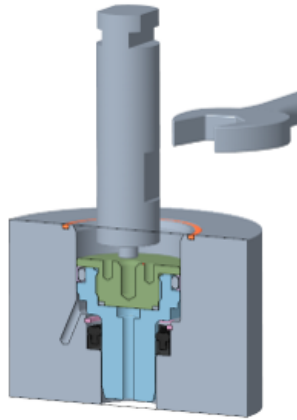
3. Insert an Allen key in the piston top.



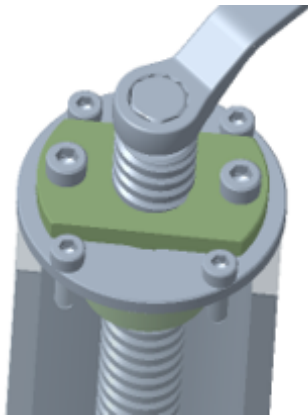
4. Use a wrench to hold the extraction tool and use an Allen key to unscrew the piston top from the assembly.

10.8.1.2 PN2310x/PN2310xL and PN2310xAR/ PN2310xLAR

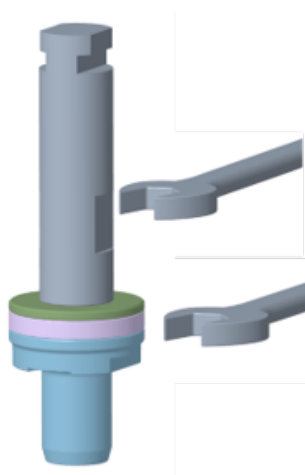
1. Screw the extraction stud into the piston top. Use a wrench if necessary.



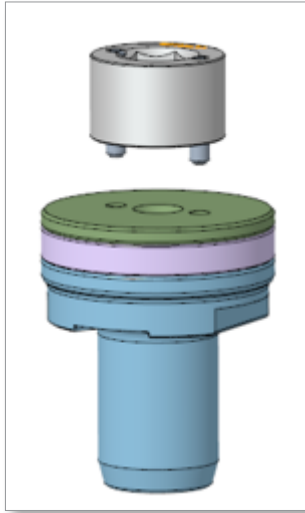
2. Attach the extraction puller (see section 10.1 Extraction Puller Overview on page 10-2) to the extraction stud.
3. Use a 13 mm (1/2") wrench or power tool to unscrew the bolt and extract the piston bottom assembly from the plate.



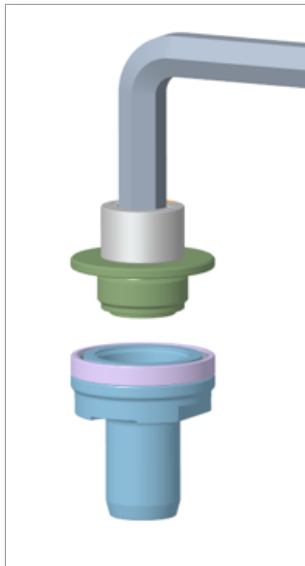
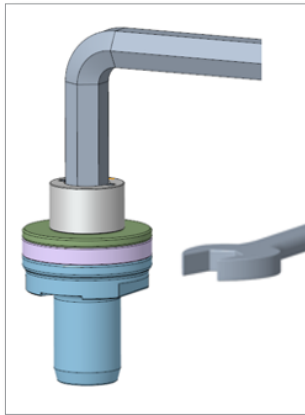
4. Attach a 28 AF wrench to the piston bottom and use a 16 AF wrench to remove the extraction stud.



5. Install the extraction tool in the piston top by aligning the two dowel holes.

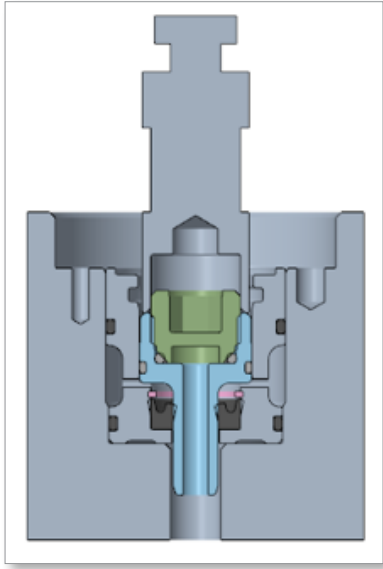


6. Hold the piston bottom with a 28 AF wrench and use a 10 mm Allen key to remove the piston top.



10.8.1.3 HY5500x/HY5500Xx/HY5500XxL

1. Screw the extraction tool into the piston top.

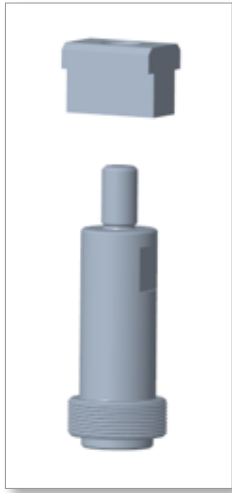


2. Attach the extraction puller (see section 10.1 Extraction Puller Overview on page 10-2) to the extraction key and remove the piston top.

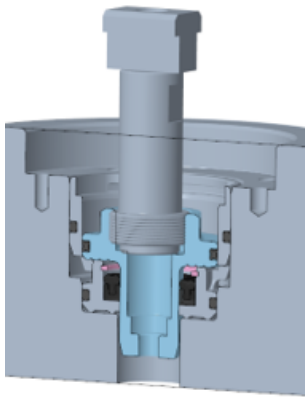
10.8.2 Extracting a Piston Bottom

10.8.2.1 HY65*, HY66*, HY67*, HY71*, HY87*, VPAC0008/9/10/11

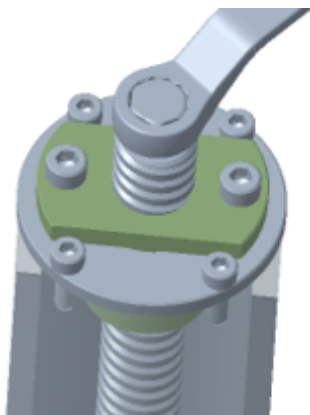
1. Screw the extraction key onto the extraction tool.



2. Screw the extraction tool assembly in the piston bottom.

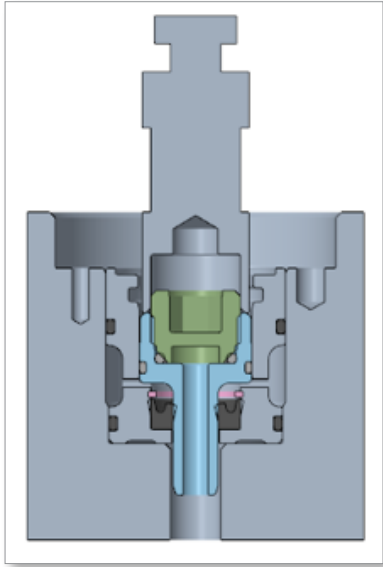


3. Attach the extraction puller (see section 10.1 Extraction Puller Overview on page 10-2) to the extraction key.
4. Use a 13 mm (1/2") wrench or power tool to unscrew the bolt and extract the piston bottom assembly from the plate.



10.8.2.2 HY5500x/HY5500Xx/HY5500XxL

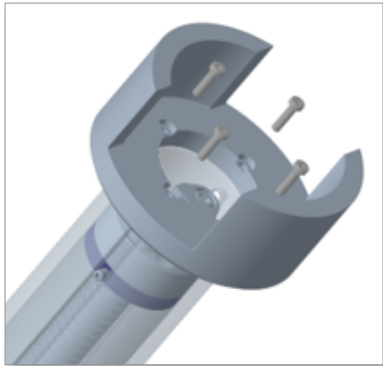
1. Screw the extraction tool into the piston top.



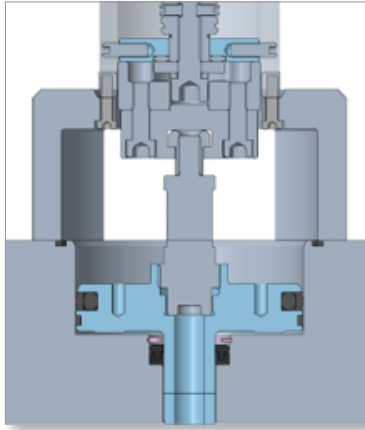
2. Attach the extraction puller (see section 10.1 Extraction Puller Overview on page 10-2) to the extraction key and remove the piston bottom.

10.8.2.3 HY680SA/SAL and HY681SA/SAL

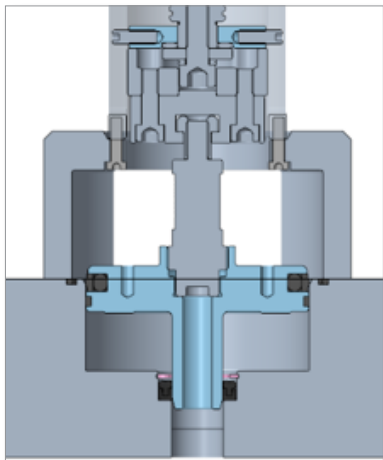
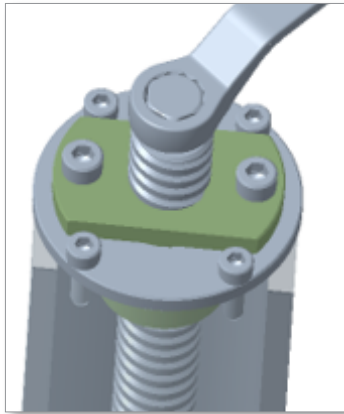
1. Screw the extraction key into the extraction tool.
2. Screw the extraction tool into the piston bottom.
3. Attach the spacer to the extraction puller (see section 10.1 Extraction Puller Overview on page 10-2).



4. Attach the extraction tool to the extraction key.

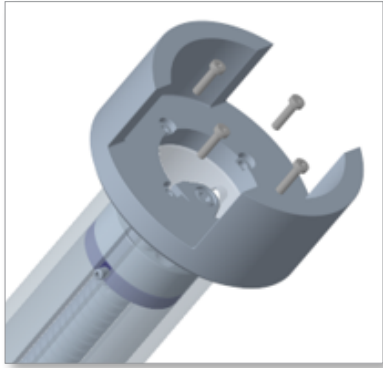


5. Use a 13 mm (1/2") wrench or power tool to unscrew the bolt and extract the piston bottom assembly from the plate.

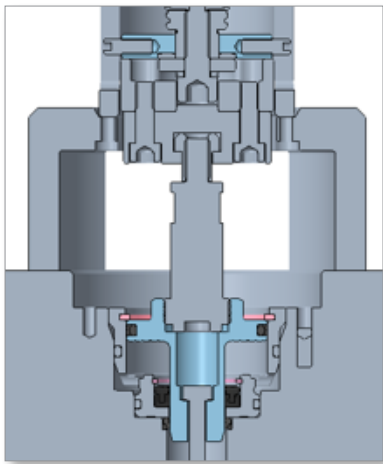
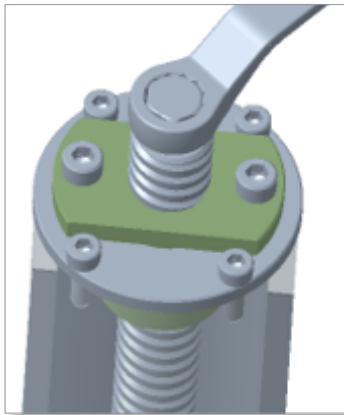


**10.8.2.4 HY8400X/85/86AR/88, PN6400X/XAR,
PN6410X/XAR, PN6400SA**

1. Screw the extraction key into the extraction tool.
2. Screw the extraction tool into the piston bottom.
3. Attach the spacer to the extraction puller (see section 10.1 Extraction Puller Overview on page 10-2).



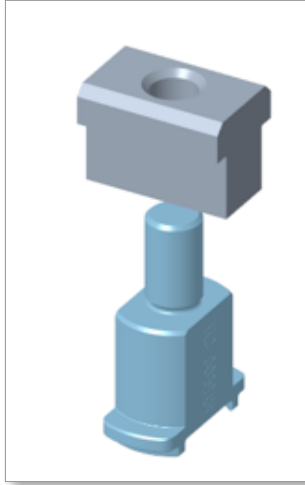
4. Use a 13 mm (1/2") wrench or power tool to unscrew the bolt and extract the piston bottom assembly from the plate.



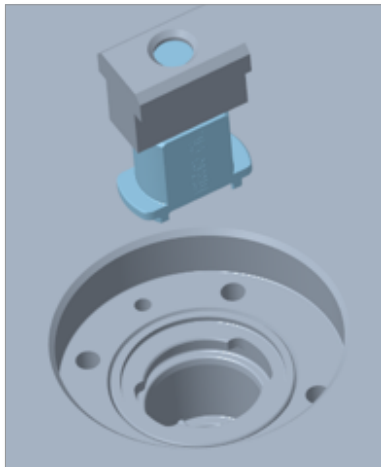
10.8.3 Extracting a Cylinder Body

10.8.3.1 HY5500x/HY5500Xx/HY5500XxL, HY65*, HY66*, HY67*, HY71*, HY87*, VPAC0008/9/10/11

1. Screw the extraction key onto the extraction tool.



2. Insert the extraction tool assembly using the slots on the cylinder body.



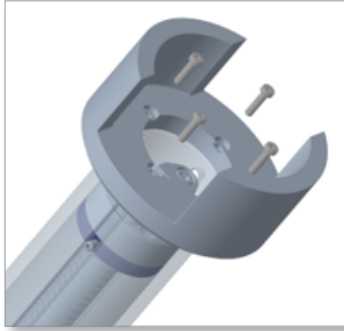
3. Rotate the extraction tool assembly by 90 degrees to lock it into position.



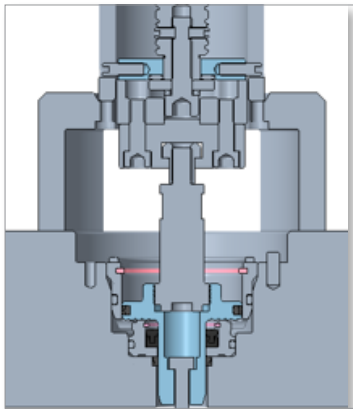
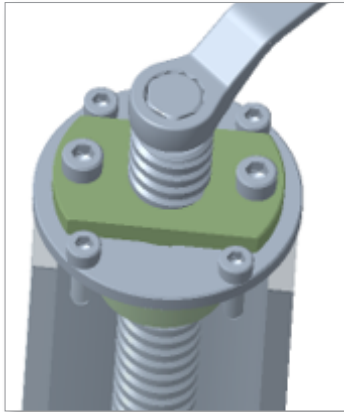
4. Attach the extraction puller (see section 10.1 Extraction Puller Overview on page 10-2) to the extraction key and remove the cylinder body.

**10.8.3.2 HY8400X/85/86AR/88, PN6400X/XAR,
PN6410X/XAR, PN6400SA**

1. Insert the retaining ring.
2. Screw the extraction key into the extraction tool.
3. Screw the extraction tool into the piston bottom.
4. Attach the spacer to the extraction puller (see section 10.1 Extraction Puller Overview on page 10-2).



5. Use a 13 mm (1/2") wrench or power tool to unscrew the bolt and extract the piston bottom assembly from the plate.



10.8.4 Extracting a Synchro Valve Pin

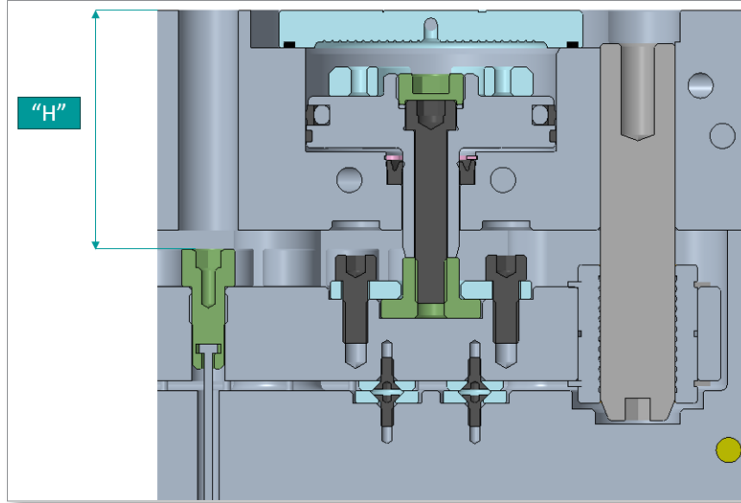


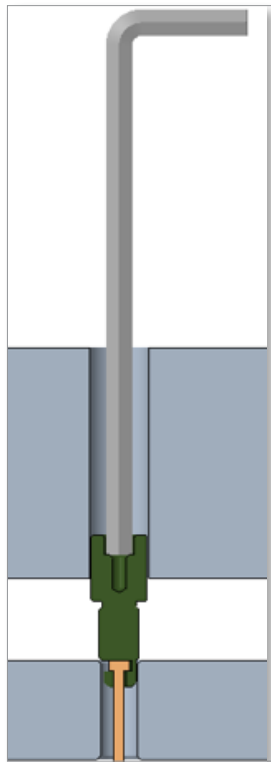
Figure 10-9 Screw length calculation

Screw length = H + 20 mm

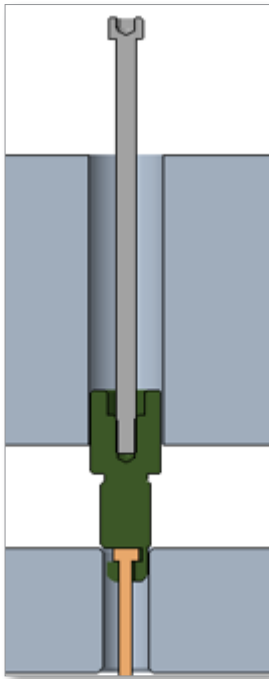
H is the distance from the top of the valve pin holder to the top of the actuator plate

Choose the nearest available standard screw length.

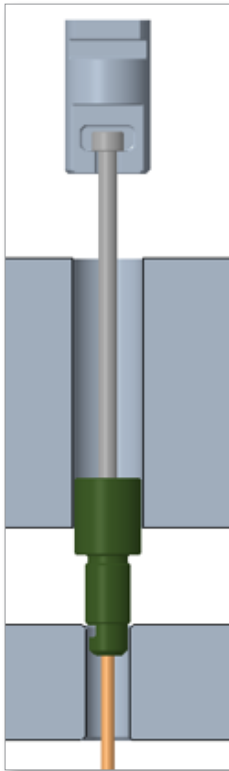
1. Use an Allen key to unscrew the valve pin holder.



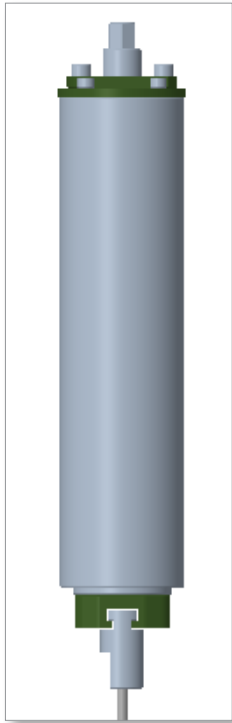
2. Insert a socket-head cap screw (M5X100; grade 10.9 or above recommended; see Figure 10-9 Screw length calculation on page 10-39 for more details) into the valve pin holder. Make sure that you are not re-inserting the valve pin holder into the synchro plate.



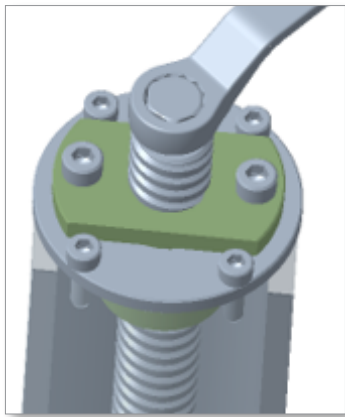
3. Attach the extraction tool (EXTOOL51) to the screw.



4. Attach the extraction puller (see section 10.1 Extraction Puller Overview on page 10-2) to the extraction tool.

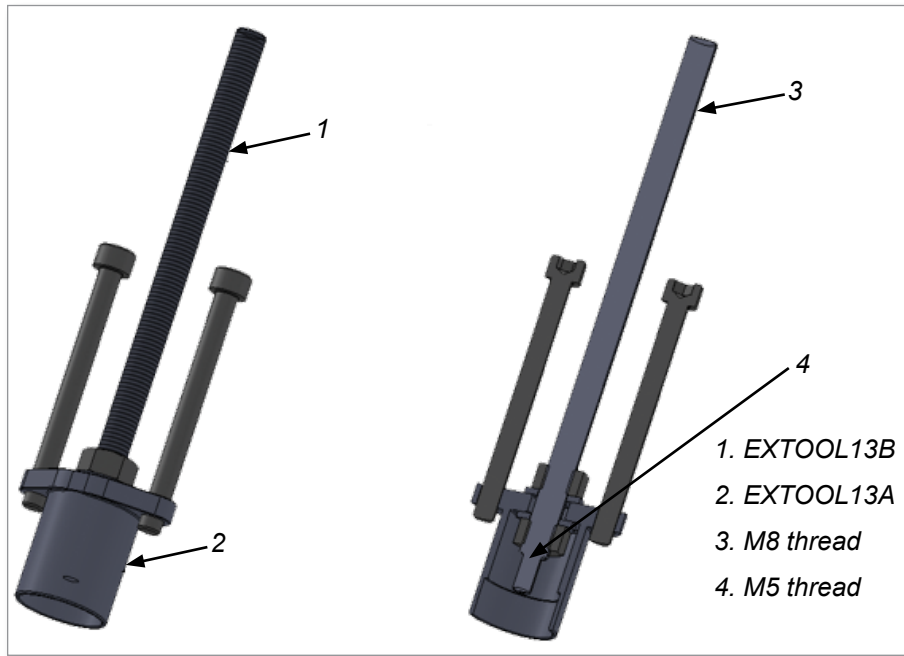


5. Use a 13 mm (1/2") wrench or power tool to unscrew the bolt and extract the valve pin.

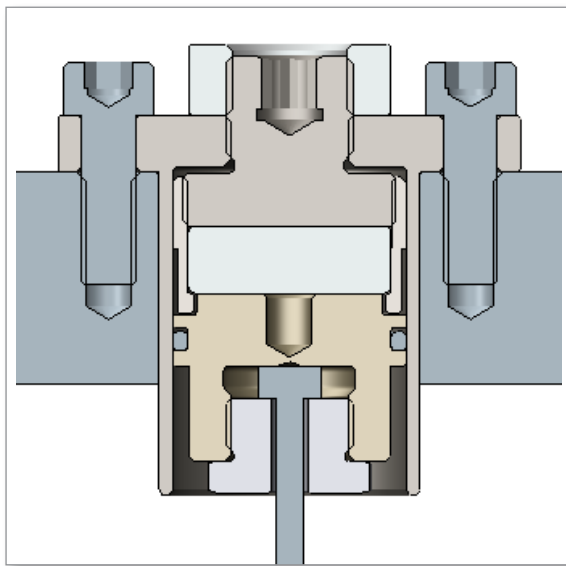


10.9 Extracting a Mag-Pin

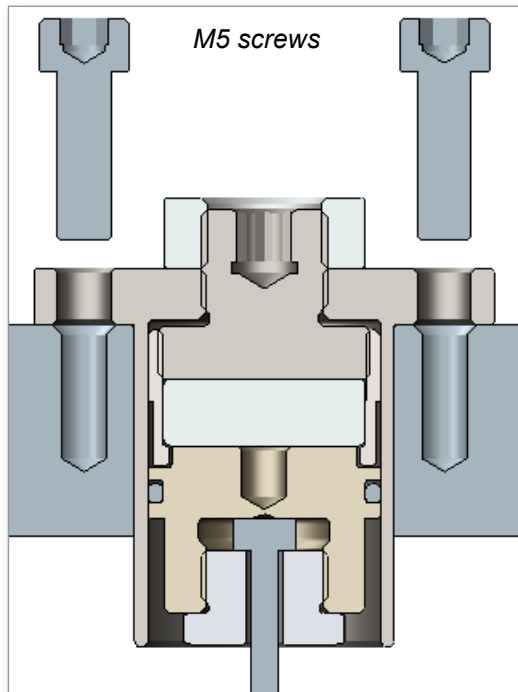
For Mag-Pin extraction, Mold-Masters recommends using the extraction tool Mold-Masters part no. EXTOOL13 (see the following) with extraction tool Mold-Masters part no. EXTOOLAS10.



1. Heat the system to the processing temperature.
2. Make sure that the manifold reaches the required temperature.
3. Extract the Mag-Pin assemblies one by one.
4. Do not lift the whole synchro-plate when the Mag-Pin assemblies are installed.

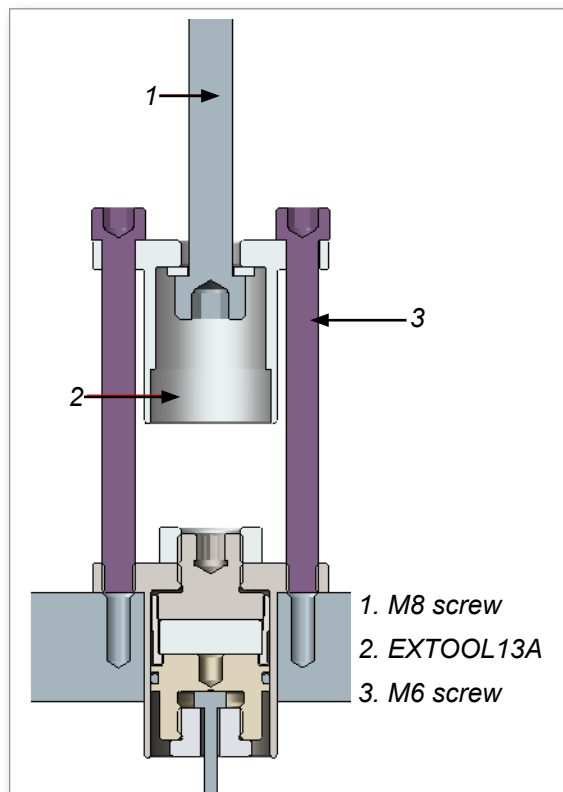


5. Remove the M5 screw from the Mag-Pin assembly.



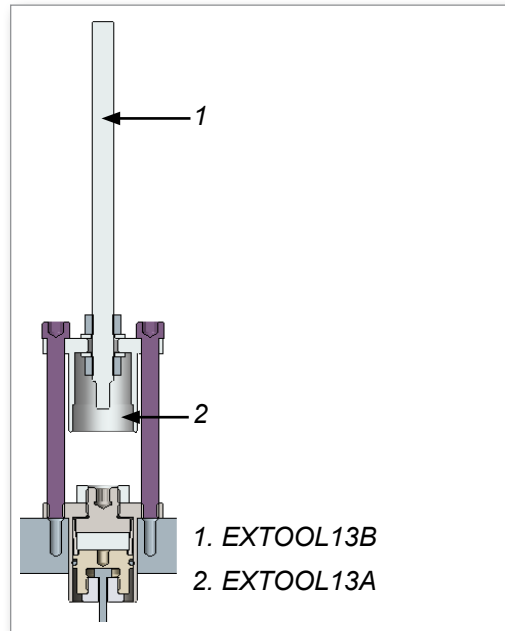
Extraction Method 1:

- a) Place the extraction tool EXTOOL13A on top of the valve pin holder.
- b) Couple the extraction tool with the M8 screw and M8 washer and extract the Mag-Pin assembly.



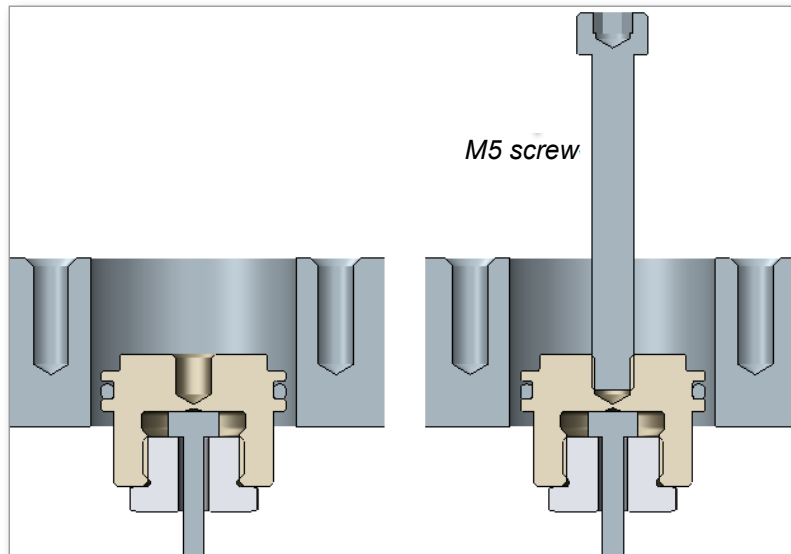
Extraction Method 2:

- a) Place the extraction tool EXTOOL13A on top of the valve pin holder.
- b) Couple the extraction tool EXTOOLAS10 with EXTOOL13B and extract the Mag-Pin assembly.

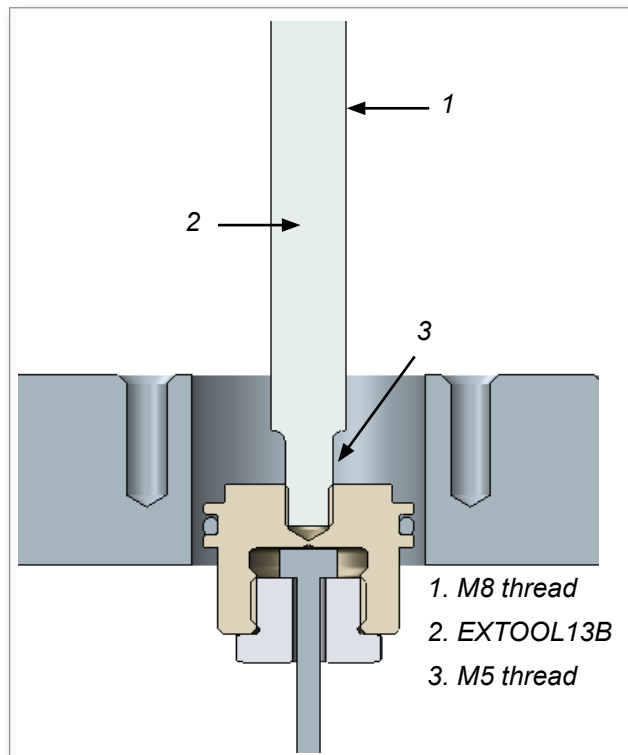


If the valve pin gets stuck in the mechanism or if it detaches from the magnet interface, choose one of the methods that follow:

- a) Method 1: Extract the valve pin and holder with a M5 screw or other adaptor with a M5 thread in front.



b) Method 2: Extract the valve pin and holder using extraction tool EXTOOLAS10 with extraction tool EXTOOL13B. Use the M5 thread end for extraction of valve pin.



10.10 Latches

There are two reasons latches are used in a mold:

1. To tie the mold halves together for transportation and handling.
2. To gain access between two mold plates which are screwed together during normal mold operation.

Latches are always used in pairs mounted on diagonally opposite sides of the mold to provide equal pull on the plates.

The latches are located on:

- The operator's side.
- Non-operator's side of the mold.
- Top and bottom of the mold.

Under no circumstances are plates to be pulled or handled with only one latch attached.

Latch locations are shown on the assembly drawings. During mold operation the latches must be removed from the mold and stored elsewhere.

10.10.1 Latching a Cavity Plate to a Core Half (Cold Half)



WARNING - LOCKOUT/TAGOUT

Make sure the machine has been locked out and tagged out in accordance to the machine's documented procedures.



WARNING - CRUSH HAZARD

Make sure the lifting eyebolt, lifting chain and crane are rated to adequately support the weight of the plate(s).



WARNING - CRUSH HAZARD

Install latches before removing the cavity plate mounting screws. Failure to do so could cause serious injury.



CAUTION

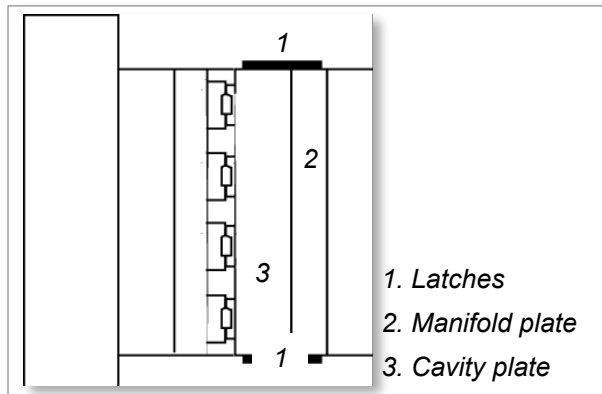
Nozzles must be within 55°C (130°F) of the mold temperature to prevent damage to the Hot Runner and mold components. For cylindrical valve gated systems, valve pins should be in the open position prior to removal of the cavity plate to prevent damage.

Use this procedure for reference purposes only. For latch locations, refer to the assembly drawings.

For additional instructions on latching in the machine refer to the machine manufacturers manual.

1. Open the mold.
2. Ensure that the machine and Hot Runner controller has been locked out and tagged out.

3. Apply lockout/tagout to the machine power source and Hot Runner controller. Refer to the controller and machine manufacturer's documentation for procedures.
4. Allow the mold to cool to room temperature. Continue to circulate the mold cooling water in all plates to cool the mold more quickly.



5. If the mold has no leader pins, attach a crane that is rated to adequately support the weight of the cavity plate.
6. Latch the cavity plate to the manifold or manifold backing plate.
7. Check that the cavity plate hoses are long enough to allow the cavity plate to be latched over to the core half (Cold Half), without damaging the hoses.
8. Remove all cavity plate mounting screws.
9. Remove lockout / tagged out.
10. Place the machine in Mold Set mode.
11. Close the mold slowly.

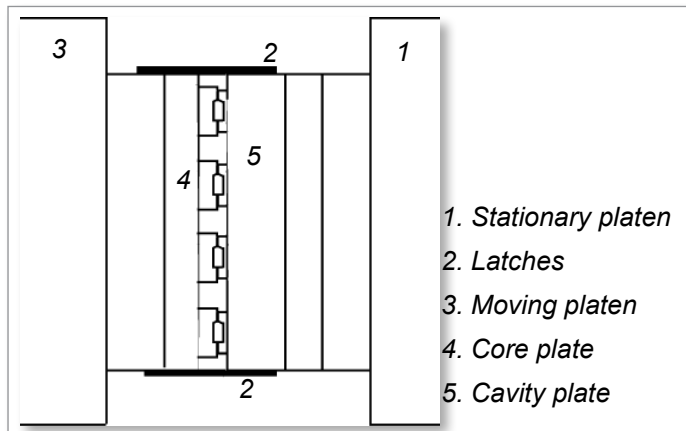


Figure 10-10 Cavity plate to core plate

12. Apply lockout / tagged out. Refer to machine manufacturer's documentation for procedures.
13. Remove the latches.
14. Latch the cavity plate to the core plate or Cold Half.
15. Remove lockout/tagout.

16. Check the machine is in Mold Set mode.
17. Open the mold moving the cavity plate away from the manifold plate.

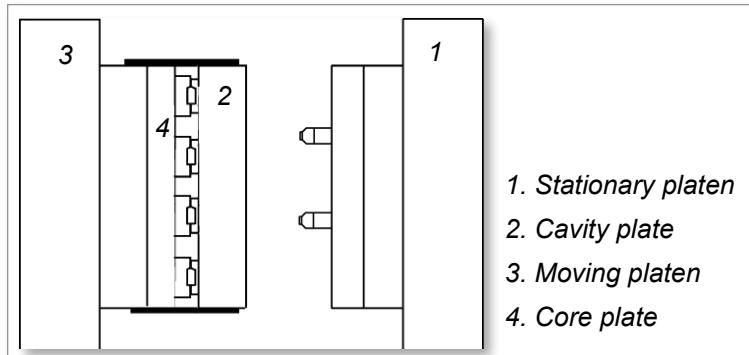


Figure 10-11 Latch cavity plate to core plate

18. Apply lockout/tagout. Refer to the controller and machine manufacturer's documentation for procedures.

10.10.2 Latching a Cavity Plate to a Manifold Plate (Hot Half)



WARNING - LOCKOUT/TAGOUT

Make sure the machine has been locked out and tagged out in accordance to the machine's documented procedures. Failure to do so could lead to serious injury or death.

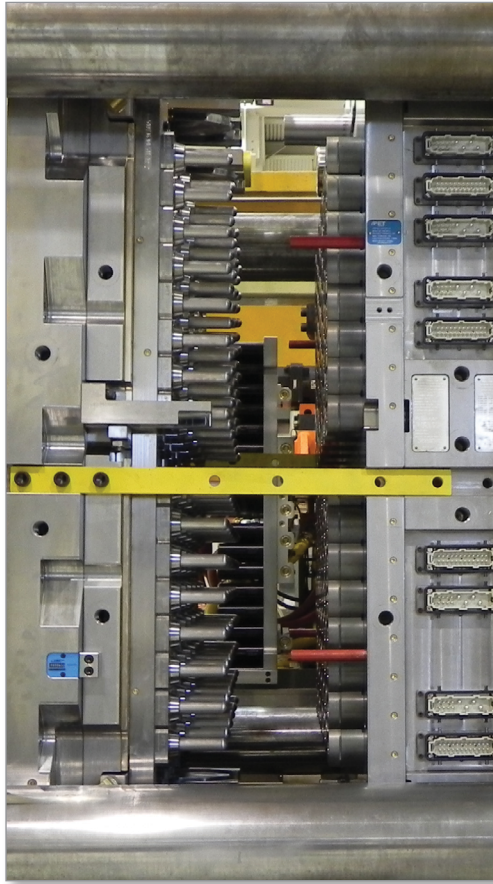


CAUTION

Nozzles must be within 55°C (130°F) of the mold temperature to prevent damage to the Hot Runner and mold components. For cylindrical valve gated systems, valve pins should be in the open position prior to removal of the cavity plate to prevent damage.

1. Check the machine is locked out / tagged out.
2. Lubricate the guide pins on the Hot Half.
3. Remove lockout/tagout.
4. Check the machine is in Mold Set mode.
5. Slowly close the mold.
6. Check the machine has been locked out / tagged out. Refer to the controller and machine manufacturer's documentation for procedures.
7. Remove the latches on both sides of the mold.
8. Latch the cavity plate to manifold plate or manifold backing plate.
9. Remove lockout/tagout.
10. Open the mold.
11. Check the machine has been locked out / tagged out. Refer to the controller and machine manufacturer's documentation for procedures.
12. Install and torque the cavity plate mounting screws. Tighten to required specifications. Refer to assembly drawings for required torque settings.
13. Install hoses if required.

14. Remove latches from both sides of the mold.



Section 11 - Troubleshooting

Molding is a complicated process with many variables to consider. If you are having problems, take a step-by-step systematic approach to find a solution that optimizes the process.

Some basic rules for troubleshooting:

- Define the problem; what is observed is only a symptom of the underlying problem.
- Develop a method to isolate the problem.
- Test one item at a time to verify results.
- Monitor the final solution to verify that the problem has been solved. Repeat occurrences of the same symptom may indicate other problems.
- Document the solution so that a repeat occurrence can be solved quickly.
- Consult other resources to augment the troubleshooting information in the attached guide. One of the best resources may be your resin supplier.

To help in this process, we welcome you to reference Mold-Masters Troubleshooting Guide which offers general information related to common issues. This document can be found in the troubleshooting section of Mold-Masters' website www.moldmasters.com. If you cannot find your issue within the documentation and continue to have problems, please contact your local Mold-Masters hot runner expert for assistance.

Section 12 - Glossary of Terms

EDM: Electrical discharge machining

TERMCON: Terminal connector

Aspect Ratio: Ratio of total flow length to average wall thickness.

Back Pressure: The pressure applied to the plastic during screw recovery. By increasing back pressure, mixing and plasticating are improved; however, screw recovery rates are reduced.

Backplate: Inlet component to the Hot Runner manifold.

Barrel: The part of the molding press where resin is melted.

B-side: The mold half that mounts to the moving side of the injection molding press. Sometimes referred to as the core side of the mold or the Cold Half, the B-side has ejector pins to push the part out of the open mold. An analysis of the part geometry determines the optimal part orientation to ensure that it will remain on the B-side when the mold is opened

Cast-in Heater Element: A heater element that is brazed in the manifold.

Clamp Force: The force required to hold the mold shut so resin cannot escape during injection.

Con.: Connector

Contoured Pins: Ejector pins with the ends shaped to match a sloping surface on the part.

Core: A convex feature on either side of the mold that will enter an opposing cavity when the mold is closed. The void between the cavity and core is where the resin solidifies and forms the part. Often the B-side of a mold is referred to as the core side.

Core-cavity: The design of a mold where the A-side forms the outside of the part and the B-side forms the inside. The advantage to this approach is that the part will shrink onto the B-side so it can be ejected, and if the inside and outside are drafted with equal and opposite draft the wall thickness will be constant.

Cycle Time: The time it takes to make one part including the closing of the mold, the injection of the resin, the solidification of the part, the opening of the mold and the ejection of the part.

Cavity: The space inside a mold into which material is injected.

Clamp: The part of an injection molding machine incorporating the platens that provides the force necessary to hold the mold closed during injection of the molten resin and open the mold to eject the molded part.

Clamping Plate: A plate fitted to a mold and used to fasten the mold to a platen.

Clamping Pressure: The pressure applied to the mold to keep it closed during a cycle, usually expressed in tons.

Closed-loop Control: System for monitoring complete, injection molding- process conditions of temperature, pressure and time, and automatically making any changes required to keep part production within preset tolerances.

Cooling Channels: Channels located within the body of a mold through which a cooling medium is circulated to control the mold surface temperature.

Cushion: Extra material left in barrel during cycle to try and ensure that the part is packed out during the hold time.

Cycle: The complete sequence of operations in a process to complete one set of moldings.

The cycle is taken at a point in the operation and ends when this point is again reached and moving platens of the clamp unit in the fully open position.

Cycle Time: The time required by an injection molding system to mold a part.

Dwell: A pause in the applied pressure to a mold during the injection cycle just before the mold is completely closed. This dwell allows any gases formed or present to escape from the molding material.

Ejector Pins: Pins that are pushed into a mold cavity from the rear as the mold opens to force the finished part out of the mold. Also called knockout pins.

Ejector Return Pins: Projections that push the ejector assembly back as the mold closes. Also called surface pins or return pins.

Ejector Rod: A bar that actuates the ejector assembly when the mold opens.

Family Mold: A multi-cavity mold where each of the cavities forms one of the component parts of an assembled finished part.

Fleeting angle: The angle at which the belt enters and exits the pulleys; it equals the sum of the parallel and angular misalignments.

Fill: The packing of the cavity or cavities of the mold as required to give a complete part or parts that are free of flash.

Flow: A qualitative description of the fluidity of a plastic material during the process of molding. A measure of its moldability generally expressed as melt flow rate or melt index.

Gate: An opening through which the melt enters the mold cavity.

Hot Tip Gate: An injection molding method that uses a heated gate on the A-side of the part to eliminate the creation of any runner or sprue. The gate vestige will be a small sharp bump that can be trimmed if necessary.

Hot Runner Mold: A mold in which the runners are insulated from the chilled cavities and are kept hot. Hot Runner molds make parts that have no scrap.

Inseal: Inlet seal

Injection: The process of forcing melted resin into a mold.

Injection Pressure: The pressure on the face of the injection screw or ram when injecting material into the mold, usually expressed in PSI or BAR.

Knockout Pins: A rod or device for knocking a finished part out of a mold.

Land: The walls of the gate, parallel or angled to the molding surface.

L/D Ratio: A term used to help define an injection screw. This is the screw length-to-diameter ratio.

Manifolds: distribute melt from the inlet component to one or more submanifolds within a Hot Runner.

Melt Flow Rate: A measure of the molten viscosity of a polymer determined by the weight of polymer extruded through an orifice under specified conditions of pressure and temperature. Particular conditions are dependent upon the type of polymer being tested. MFR usually is reported in grams per 10 minutes. Melt flow rate defines the flow of a polypropylene resin. An extrusion weight of 2160 grams at 446°F (230°C) is used.

Melt Flow Index: Term that defines the melt flow rate of a polyethylene resin. An extrusion weight of 2160 grams at 310°F (190°C) is used.

Mold: A series of machined steel plates containing cavities into which plastic resin is injected to form a part.

Mold Frame: A series of steel plates which contain mold components, including cavities, cores, runner system, cooling system, ejection system, etc.

Mold-Temperature-Control Unit: Auxiliary equipment used to control Hot Runner temperature. Some units can both heat and cool the mold. Others, called chillers, only cool the mold.

Moving Platen: The platen of an injection molding machine that is moved by a hydraulic ram or mechanical toggle.

Multi-Cavity Mold: A mold having two or more impressions for forming finished items in one machine cycle.

Multi-Material Molding: The injection of two-or-more materials, in sequence, into a single mold during a single molding cycle. The injection molding machine is equipped with two-or-more plasticators. (See also co-injection)

Nest Plate: A retainer plate in the mold with a depressed area for cavity blocks.

Non-Fill: See short shot.

Non-Return Valve: Screw tip that allows for material to flow in one direction and then closes to prevent backflow during injection.

Machine Nozzle: The hollow-cored, metal nose screwed into the injection end of a plasticator. The nozzle matches the depression in the mold. This nozzle allows transfer of the melt from the plasticator to the runner system and cavities.

Packing: The filling of the mold cavity or cavities as full as possible without causing undue stress on the molds or causing flash to appear on the finished parts. Over- or under-packing results in less than optimum fill.

PET: Polyethylene Terephthalate, a type of polyester and a leading recyclable plastic material.

Pinpoint Gate: A restricted gate of 0.030 in. or less in diameter, this gate is common on Hot Runner molds.

Platens: The mounting plates of a press on which the mold halves are attached.

Preform: A plastic test tube shaped part produced by injection molding systems in the first step of a two-stage injection molding and blow molding process used to produce PET bottles or containers. The preform is subsequently re-heated and stretch blown through a blow molding process into the final container shape.

Pressure Disk: Manifold component designed to be compressed by thermal expansive forces to form part of the plastic sealing mechanism. Also helps to reduce thermal transfer to a minimum.

Process: The injection molding environment consisting of input variables such as temperature, pressure, injection rates and time that are controlled to fill the mold while optimizing the trade-offs between cosmetics and dimensional accuracy.

Ram: The forward motion of the screw in the barrel that forces the melt into the mold cavity.

Recovery Time: The length of time for the screw to rotate and create a shot.

Retainer Plate: The plate on which demountable pieces, such as mold cavities, ejector pins, guide pins and bushings are mounted during molding.

Ring Gate: Used on some cylindrical shapes. This gate encircles the core to permit the melt to first move around the core before filling the cavity.

Runner: The channel that connects the sprue with the gate for transferring the melt to the cavities.

Runnerless Molding: See Hot Runner mold.

Scrap: Parts that do not meet the quality standards.

Screw Travel: The distance the screw travels forward when filling the mold cavity.

Shear: The force between layers of resin as they slide against each other or the surface of the mold. The resulting friction causes some heating of the resin.

Short Shot: Failure to completely fill the part or cavities of the mold. Edges may appear melted.

Shot: The complete amount of melt injected during a molding cycle, including that which fills the runner system.

Shot Capacity: Generally based on polystyrene, this is the maximum weight of plastic that can be displaced or injected by a single injection stroke. Generally expressed as ounces of polystyrene.

Single-Cavity Mold: A mold having only one cavity and producing only one finished part per cycle.

Sprue Bushing: A hardened-steel insert in the mold that accepts the Screw nozzle and provides an opening for transferring the melt.

Sprue Gate: A passageway through which melt flows from the nozzle to the mold cavity.

Sprue: The feed opening provided in injection molding between the nozzle and cavity or runner system.

Stationary Platen: The large front plate of an injection molding press to which the front plate of the mold is secured. This platen does not move during normal operation.

Step: A transition component that provides a slight separation between the bridge and the manifold and that allows the melt passage to connect the bridge and manifold.

Thermal gate: A gate that is closed by temperature. Resin solidifies in the gate to block resin from flowing out of the hot runner.

Thermoplastic: A polymer which melts or flows when heated. Thermoplastic polymers are usually not highly cross-linked, and act much like molecular solids: low melting and boiling points, high ductile strength.

Thermoset: A polymer that does not melt when heated. Thermoset polymers “set” into a given shape when first made and afterwards do not flow or melt, but rather decompose upon heating. They are often highly cross-linked polymers, with properties similar to those of network covalent solids, i.e., hard and strong.

Valve Disk: Manifold component designed to be compressed by thermal expansive forces to form part of the plastic sealing mechanism. Its high tolerance bore allows the valve pin to shift through it without plastic leaks and part of it enters the melt stream and helps guide the plastic flow without stagnation.

Valve Gating: An injection molding method that uses a mechanical shut off to open and close the gate orifice.

Vent: A shallow channel or opening cut in the cavity to allow air or gases to escape as the melt fills the cavity.

Some glossary content © DRM Associates 2008 / © Protomold 1999-2009

Index

A

- Accu-Line system
 - assembling...5-90, 5-100
 - assembly
 - single nozzle valved...5-89
 - with valve insert...5-97
- actuator. *See also* valve actuator
- extraction tools...10-27
- actuators...10-26

B

- backup ring...5-44
- ball screw...5-65
 - assembly...5-65
 - lubricating...5-70
 - maintenance...5-72
- belt. *See* tension belt
- bolt-in system...5-2
- brazed-in system...5-1

C

- center heater
 - direct mount...5-38
 - indirect mount...5-39
- color change
 - comprehensive method...9-2
 - general...9-1
 - simple method...9-1
- crimping tool...5-119, 10-19
- cylinder
 - body: extraction...10-37
 - bottom: installation...5-44
 - top: assembly...5-46

D

- DeXa systems (side gating)
 - four-tip nozzle description...5-152
 - four-tip nozzle package...5-153
 - overview...5-152
 - terminal and wiring orientation...5-153
 - two-tip nozzle description...5-152
- disposal...3-12
- dowel pin
 - manifold-locating...5-23

E

- E-Drive...5-63
 - belt misalignment...5-77
 - components...5-65
 - tension belt
 - assembly...5-72
 - installation...5-75
- electrical testing...7-1 to 7-5
- external heater plates...5-34
- extraction
 - general...10-2
 - mag-pin...10-42
 - tools: extraction puller...10-2
 - valve disk
 - one-piece...10-3, 10-6
 - two-piece: groove extraction...10-13
 - two-piece: thread extraction...10-10

F

- fix idler...5-65

G

- gate insert
 - water-cooled: installation...5-4
- gate seal
 - cleaning...10-22
 - finishing...5-4
 - maintenance...10-20
 - removing...10-21
 - replacing...10-22
 - TIT edge: removal...5-110
- gating
 - two- vs. four-gate nozzles...5-152
- glossary of terms...12-1
- ground shorts test...7-2

H

- hazard areas...3-2
- heater continuity...7-4
- heater plate
 - installing...5-34
- heater zones
 - four-tip zoning diagram...5-155
 - two-tip zoning diagram...5-155
- hot half
 - assembly...6-1
- hydraulic limit switch
 - installing...5-58
 - testing...5-61

I

- IMM
 - overview...3-2
- injection molding machine. *See* IMM
- inlet components
 - inlet extension...5-40
 - inlet extension with pressure sleeve...5-41
 - inlet seal installation...5-25
 - installing...5-36
- insulation plate...5-74

L

- latches...10-46
- lubricant. *See* ball screw, lubricant

M

- magnets...5-82
- mag-pin
 - assembling...5-83
 - assembly...5-79
 - extraction...10-42
 - operation...5-80
- maintenance...10-1
 - general...10-1
 - Melt-Cube. *See* Melt-Cube system, maintenance
 - toolkit
 - Melt-Cube design A...5-125
 - Melt-Cube design B...5-140
- manifold
 - installation...5-21
 - locator...5-22
 - main: installation...5-25
 - thermocouple installation...5-24
- Master-Shield system...5-3
 - components...5-10
 - non-valved system...4-9
 - valve gate system...4-10
- Melt-Cube system
 - clamp-screw torque chart...5-131
 - components...5-124
 - design A/B: identifying...5-122
 - example system...5-123
 - general...5-121
 - installing in cavity block...5-145
 - maintenance
 - toolkit...5-125, 5-140
 - melt-transfer-link torque chart...5-128
 - shutdown...8-6
 - startup...8-4
- Melt-Disk
 - attaching to nozzle...5-117
 - preparing and cleaning...5-113
 - re-assembly after maintenance...10-25

- startup and shutdown...8-3
- thermocouple assembly...5-115
 - with cast-in heater element...5-112
- Melt-Link
 - installing...5-128
 - one-piece...5-118
 - reverse two-piece...5-117
- melt wedge screws
 - tightening...5-134
- mold plug...7-4
- motor mount...5-65

N

- non-valved system...4-6
 - with Master-Shield...4-9
- nozzle
 - bore depth: calculating...5-27
 - four-tip DeXa
 - package components...5-152
 - four-tip DeXA...5-152
 - installing...5-9
 - step: installing...5-17
 - tip height: checking...10-24
 - two-tip DeXa...5-152
 - well depth...6-1
 - wire: layout...5-18

P

- paste-in system. *See* brazed-in system
- piston
 - assembly...5-45
 - bottom: extracting...10-33
 - top: extracting...10-28
- power lead
 - installing...10-20
 - removing...10-19
- pressure disk...5-26
 - final grinding...5-27
 - installing...5-29
- proximity sensor
 - installing...5-59
- puller. *See* extraction puller

Q

- quick disconnects
 - crimping...5-120
 - general...5-119

R

- release details
 - document...1-1
- reverse Melt-Link system
 - identifying...5-111
 - shutdown...8-6

S

- safety
 - general symbols...3-7, 3-13
 - hazard areas...3-2
 - lockout...3-10
- screws...4-2
- shutdown
 - general...8-5
 - Melt-Cube...8-6
 - Melt-Disk...8-5
 - Melt-Link...8-6
 - reverse Melt-Link...8-6
- side gating
 - DeXa...5-152
- single nozzle
 - valved system (Accu-Line)...5-89
- speed-LOK bolt...5-154
- stack-mold cavity plate
 - installing...6-3
- startup
 - general...8-1
 - pre-startup checks...8-1
- support...2-1
- support bushing
 - installing...5-31
- synchro-plate
 - assembling...5-69
- synchro valve pin
 - extracting...10-39

T

- temperatures...5-66
- tension belt
 - assembling...5-72
 - installing...5-75
 - torque...5-73
- tensioning idler assembly...5-65
- terminal ends
 - assembling...10-17
 - assembly
 - heater plate...10-19
 - nozzle...10-16
 - installing...10-16
 - removing...10-16
- testing. *See* electrical testing
- thermocouple
 - back mounted...5-18
 - continuity test...7-3
 - front mounted...5-18
 - installing...5-5
 - manifold: installing...5-24
 - removing...5-8

- TIT edge-gated system
 - gate seal removal...5-110
- tools
 - crimping tool...5-119
 - extraction puller...10-2
 - required...4-1
- torque settings...4-3
 - components...4-4
 - Melt-Cube clamp screw...5-131
 - melt transfer link...5-128
 - plate assembly screws...4-4
 - system assembly screws...4-4
- transfer-seal/torpedo
 - disassembling...5-136
 - replacing...5-136
- troubleshooting...11-1

U

- user-manual release details...1-1

V

- valve actuator
 - assemblies...5-42
 - cylinder bottom assembly...5-44
 - cylinder top assembly...5-45
 - installing in hydraulic plate...5-56
- valve bushing
 - installing...5-19
 - types...5-19
- valve disk
 - installing...5-26
 - removal...10-3
 - two-piece...5-30
- valve gate system...4-7
 - air circuits...5-43
 - with Bridge...4-8
 - with Master-Shield technology...4-10
- valve pin
 - head finishing...5-53
 - tapered: lapping...5-52
 - tip finishing...5-46
 - 5500 series...5-46
 - 7100 series...5-48, 5-50, 5-51

W

- warranty...1-2
- wiring check...3-8
- wiring diagram
 - four-tip nozzle...5-155
 - two-tip nozzle...5-155



Scan the QR code for our global contacts: