



E-Multi[®]



Auto-Lube User Manual

version 1



Contents

Section 1 - Introduction	1-1
1.1 Copyright	1-1
1.2 Units of Measure and Conversion Factors	1-1
1.3 Warranty	1-2
1.4 Document Release Details	1-2
Section 2 - Global Support	2-1
2.1 Worldwide Locations	2-1
Section 3 - Safety Information.....	3-1
3.1 Personal Protective Equipment	3-1
3.2 Warning Labels.....	3-1
3.3 General Safety Information.....	3-1
3.3.1 User Responsibility	3-2
3.3.2 Safety First.....	3-2
3.3.3 Operation Zone.....	3-2
3.3.4 Hazards	3-2
3.3.5 Reasonable Use	3-3
3.3.6 Intended Purpose	3-3
3.3.7 Waste Disposal.....	3-3
3.3.8 Lubricant Use.....	3-3
Section 4 - User Interface	4-1
4.1 Control Panel of the Lubrication Pump.....	4-1
4.2 Auto-Lube Screen of the E-Multi Controller	4-3
Section 5 - Components	5-1
5.1 Specifications	5-1
5.2 Orientation of Auto-Lube System for a Horizontal E-Multi	5-2
5.3 Orientation of the Auto-Lube System for a Vertical E-Multi	5-3
Section 6 - Installation	6-1
6.1 Material Handling.....	6-1
6.1.1 Inspection	6-1
6.2 Transport and Storage.....	6-1
6.2.1 Packaging	6-1
6.2.2 Transport.....	6-1
6.2.3 Storage	6-1
6.3 Electrical Connections	6-2
6.3.1 E-Multi controller.....	6-2
6.3.2 Auto-Lube pump	6-3
6.3.3 Extension cable	6-3
6.3.4 Connecting the power/data cable	6-4
6.3.5 Changing the operating mode to pulse control	6-5

Section 7 - Operation	7-1
7.1 Activation Key	7-1
7.1.1 Installing the activation key	7-1
7.1.2 Removing the activation key	7-2
7.2 Priming the Auto-Lube system	7-3
7.2.1 Stopping the priming of the Auto-Lube system	7-5
Section 8 - Maintenance	8-1
8.1 Maintenance Schedule	8-1
8.1.1 Visual inspection	8-1
8.1.2 Cleaning the Auto-Lube system	8-2
8.1.3 Replacing the lubrication cartridge	8-2
8.1.4 Filling a lubrication cartridge	8-8
8.1.5 Decommissioning	8-12
8.1.6 Recommissioning	8-12
Section 9 - Troubleshooting	9-1
9.1.1 Error E1	9-1
9.1.2 Error E2	9-2
9.1.3 Error E3	9-3
9.1.4 Error E4	9-4
9.1.5 Error E7	9-5
Section 10 - Service	10-1
10.1 Spare Parts	10-1
Index	I

Tables

Table 1-1 Units of Measure and Conversion Factors	1-1
Table 1-2 Document Release Details	1-2
Table 4-1 Control Panel	4-1
Table 4-2 Modes and Functions	4-2
Table 4-3 Auto-Lube Screen of the E-Multi Controller	4-3
Table 5-1 Specifications.....	5-1
Table 6-1 E-Multi Controller Connections	6-2
Table 6-2 Auto-Lube Pump Connections	6-3
Table 8-1 Maintenance Schedule	8-1
Table 9-1 Error Messages	9-1
Table 9-2 Error E1	9-1
Table 9-3 Error E2	9-2
Table 9-4 Error E3	9-3
Table 9-5 Error E4	9-4
Table 9-6 Error E7	9-5

Figures

Figure 4-1 Control panel.....	4-1
Figure 5-1 Orientation of Auto-Lube system for a horizontal E-Multi.....	5-2
Figure 5-2 Orientation of Auto-Lube system for a vertical E-Multi.....	5-3
Figure 6-1 Connecting the power/data cable.....	6-4
Figure 7-1 Activation key.....	7-1
Figure 8-1 Installing a lubrication cartridge.....	8-5
Figure 9-1 Error E1.....	9-1
Figure 9-2 Error E2.....	9-2
Figure 9-3 Error E3.....	9-3
Figure 9-4 Error E4.....	9-4
Figure 9-5 Error E7.....	9-5

Section 1 - Introduction

This manual provides information about the Auto-Lube system for Injection machines. The Injection machine is equipped with a manual Auto-Lube system by default. The E-Multi Auto-Lube system is an optional setup that can replace the manual Auto-Lube system.

The E-Multi Auto-Lube system eliminates the requirement for manual lubrication and can deliver the precise quantity of lubricant required. The E-Multi Auto-Lube system is equipped with a Auto-Lube pump that has four pump bodies (P1, P2, P3, and P4). Each pump body has two lubrication outlets.

1.1 Copyright

© 2025 Mold-Masters (2007) Limited. All Rights Reserved. Mold-Masters® and the Mold-Masters logo are trademarks of Mold-Masters.

1.2 Units of Measure and Conversion Factors



NOTE

The dimensions given in this manual are from original manufacturing drawings.

All values in this manual are in S.I. units or subdivisions of these units. Imperial units are given in parentheses immediately after the S.I. units.

Table 1-1 Units of Measure and Conversion Factors		
Abbreviation	Unit	Conversion Value
bar	Bar	14.5 psi
in.	Inch	25.4 mm
kg	Kilogram	2.205 lb
kPa	Kilopascal	0.145 psi
gal	Gallon	3.785 l
lb	Pound	0.4536 kg
lbf	Pound force	4.448 N
lbf.in.	Pound force inch	0.113 Nm
l	Litre	0.264 gallon
min	Minute	
mm	Millimeter	0.03937 in.
mΩ	Milli Ohm	
N	Newton	0.2248 lbf
Nm	Newton Meter	8.851 lbf.in.
psi	Pound per square inch	0.069 bar
psi	Pound per square inch	6.895 kPa
rpm	Revolutions per minute	
s	Second	
°	Degree	
°C	Degree Celsius	0.556 (°F -32)
°F	Degree Fahrenheit	1.8 °C +32

1.3 Warranty

For current warranty information please refer to the documents available in the support section of our website: <https://www.moldmasters.com> or contact your Mold-Masters representative.

1.4 Document Release Details

Table 1-2 Document Release Details		
Document Number	Release Date	Version
UM--AL--ENG--01	March 2026	1.0

Section 2 - Global Support

2.1 Worldwide Locations

To find your nearest Mold-Masters office for sales or service support, please visit www.moldmasters.com/location-map or scan this QR code:



Section 3 - Safety Information

3.1 Personal Protective Equipment

You must wear personal protective equipment (PPE) when you work with the machine. PPE includes safety glasses, ear plugs with specified noise reduction ratings (NRR) for the task and a respirator with a proper filter.

3.2 Warning Labels

The following information is given for your personal safety and for the protection of the plant or individual units, or of devices and machines connected thereto. If this information is unclear, please ask your supervisor.



DANGER

Danger means that death or severe injury will be caused. Appropriate safety precautions must be taken.



WARNING

Warning means that personnel injury can be caused. Appropriate safety precautions must be taken.



CAUTION

Caution means that material damage can be caused. Appropriate safety precautions must be taken.



NOTE

Note means that there is an additional information that is useful. Appropriate actions should be taken.

3.3 General Safety Information



DANGER

Damaged or electrical connections that are not approved by the manufacturer can cause personal injury or death. Only approved personnel can work with the electrical connections. Damaged electrical connections must be replaced immediately.



DANGER

Lubricants are flammable. Do not use water to extinguish the fire. Extinguish the fire with the correct extinguisher: powder, foam, or carbon dioxide. For more information, refer to the safety data sheet from the lubricant manufacturer.

**WARNING**

Lubricants can cause irritation to your skin. Be careful that you do not get lubricant on your skin.

**CAUTION**

Mounting bolts that are not tight or that are overloaded can cause damage to the Auto-Lube system. Make sure that the mounting bolts are tightened with a calibrated torque wrench as per the torque specification.

**NOTE**

Lubricants can contaminate soil and water. Make sure that you properly discard of lubricants. Only approved personnel who have read this manual can work with the Auto-Lube system. Follow local and/or company regulations.

3.3.1 User Responsibility

Section 3.3 General Safety Information gives basic safety information. A supervisor must use this information when doing the procedures for operation, installation, removal, maintenance, and cleaning of the Auto-Lube system.

When you make changes to the Auto-Lube system, make sure to review all the safety procedures and change the procedures if necessary. Speak with the manufacturer to make sure that the changes can be made to the machine.

3.3.2 Safety First

Modern machines are made as per the accepted safety standards.

The conditions for safe operation are as follows.

- Follow the safe operation procedures.
- Regular maintenance and service done by certified personnel.

3.3.3 Operation Zone

Prepare an operation zone around all installed machines and identify the zone with warning stripes or a brightly painted rail guard. The operation zone must have sufficient space for the personnel to work safely with the Auto-Lube system. Only approved personnel can be in the operation zone when the Auto-Lube system is in operation. Keep the operation zone clear of unnecessary tools, equipment, and any objects that may interfere with the safe operation of the machine.

3.3.4 Hazards

Make sure that you operate Auto-Lube system only in technically safe conditions. Before you operate the machine, read *Section 3.3 General Safety Information*.

3.3.5 Reasonable Use

Make sure that you operate the Auto-Lube system as per the technical specifications given in *Section 5.1 Specifications on page 5-1*. Failure to do so can cause damage to the Auto-Lube system.

3.3.6 Intended Purpose

Do the instructions that follow for safe operation of the Auto-Lube system.

- Do not make any changes to the Auto-Lube system.
- When the Auto-Lube system is in operation, do a visual inspection of the system and lubrication points. If you find a problem, correct the problem.
- To refill the lubrication cartridge, do the instructions given in *Section 8.1.4 Filling a lubrication cartridge*
- Obey the rules on work safety, accident prevention, and environmental protection.

3.3.7 Waste Disposal

Obey national regulations when you discard an open or empty lubrication cartridge. For more information, refer to the safety data sheet from the component manufacturer.

3.3.8 Lubricant Use



CAUTION

Make sure you use the correct lubricant. Lubricant information is on the label of the lubrication cartridge.

- Only use lubricants approved by the manufacturer.
- Make sure that the lubricant is manufactured to use with the Auto-Lube system and the lubricant is delivered in its original lubrication cartridge.
- For more information, speak with the lubricant manufacturer to get the safety data sheet and other documentation.

Section 4 - User Interface

4.1 Control Panel of the Lubrication Pump

The control panel of the Auto-Lube system shows information about the current operation and the status of errors. The control panel has seven LED indicators and two input buttons. The LCD shows the status of operation and the status of errors.

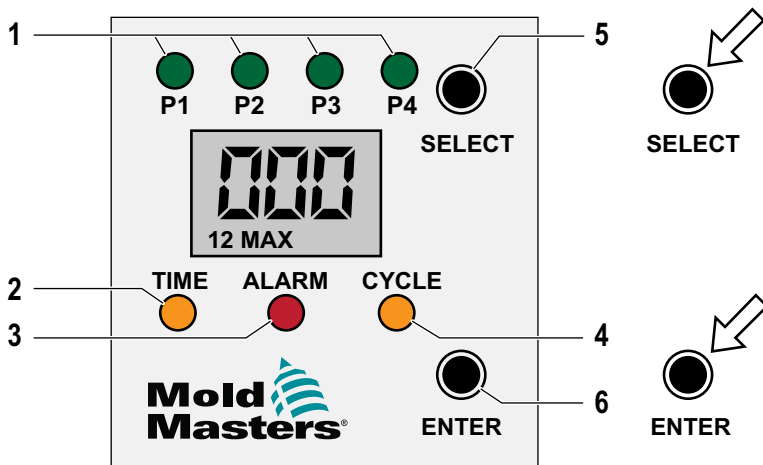

Figure 4-1 Control panel



NOTE

The control panel only responds to inputs made using the activation key. For information about the activation key, see *Section 7.1 Activation Key on page 7-1*.



CAUTION

Do not use the Auto-Lube pump control panel after the Auto-Lube pump is connected to the E-Multi controller, Only use the E-Multi touchscreen to operate the Auto-Lube pump.

Table 4-1 Control Panel			
Callout No.	Category	Name	Description
1	Green LED Indicator	P1, P2, P3, P4	Pump body
2	Orange LED Indicator	TIME	Active pump indicator
3	Red LED Indicator	ALARM	Error messages
4	Orange LED Indicator	CYCLE	Number of delivery strokes in one operation
5	Input button	SELECT	The Select button is used to select the different input parameters.
6	Input button	ENTER	The Enter button is used to confirm the selected input parameter.

Refer to the table that follows for information about the functions of the control panel.

Table 4-2 Modes and Functions	
Function	Description
Run	Back pressure check by special delivery of lubrication
Pro	Programming mode (other functions). PIN protected
ESC	Exit the menu level.
On	Operating mode: time control
PuO	
PAU	Operating mode: pulse control
Pul	
PIN	Enter/change PIN
CLr	Delete critical error message and terminate fill cycle (FIL) prematurely.
FIL	Control function for commissioning
FO	Feedback function (motor run control)
FI	

4.2 Auto-Lube Screen of the E-Multi Controller

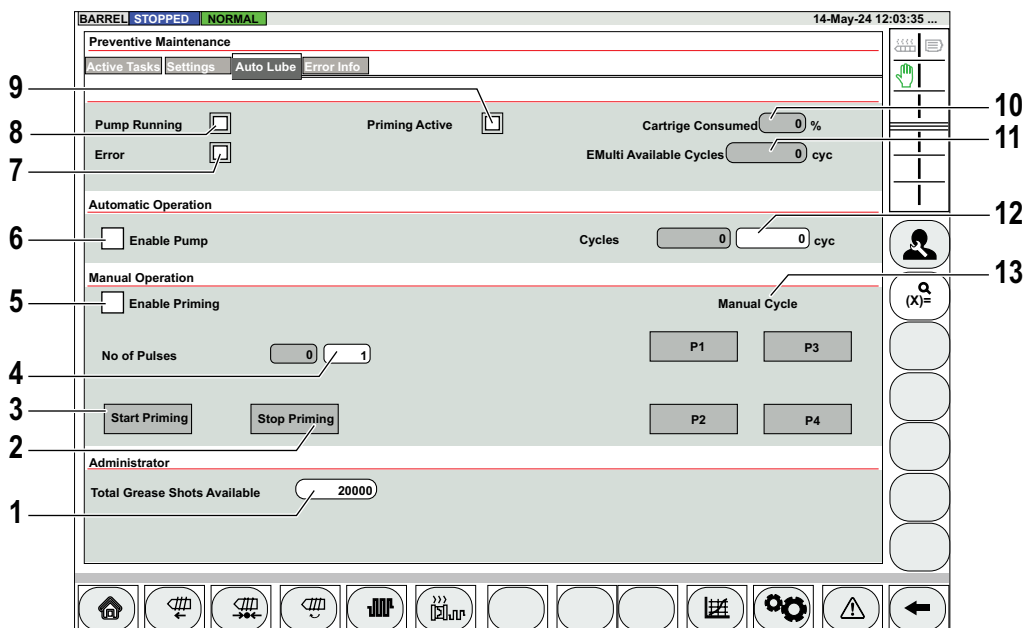

NOTE

The Auto-Lube system requires controller software version v134_250328 or newer.

Table 4-3 Auto-Lube Screen of the E-Multi Controller

Callout No.	Name	Description
1	Total Lubrication Shots Available	<ul style="list-style-type: none"> The total number of lubrication shots available is displayed in this field. This function is available only to the administrator.
2	Stop Priming	<ul style="list-style-type: none"> "Stop Priming" is an input button. Click "Stop Priming" to stop the operation of the Auto-Lube pump in priming mode.
3	Start Priming	<ul style="list-style-type: none"> "Start Priming" is an input button. Select "Start Priming" to operate the Auto-Lube pump in priming mode.
4	No of pulses	<ul style="list-style-type: none"> "No of Pulses" is an input field. Enter the number of pulses for one cycle.
5	Enable Priming	Click the "Enable Priming" checkbox to enable or disable the priming function.
6	Enable Pump	The "Enable Pump" checkbox will be checked automatically when the pump is operating to supply lubricant.
7	Error	<ul style="list-style-type: none"> The "Error" checkbox will be checked when there is an error in the Auto-Lube system. Refer to the LCD of the control panel for the error code.
8	Pump Running	The "Pump Running" checkbox is enabled when the Auto-Lube pump is in operation.

Callout No.	Name	Description
9	Priming Active	The "Priming Active" checkbox is enabled when the priming function is in operation.
10	Cartridge Consumed	The percentage of cartridge used is displayed in this field.
11	EMulti Available Cycles	The total number of E-Multi cycles available is displayed in this field.
12	Cycles	<ul style="list-style-type: none"> "Cycles" is an input field. Supervisors and admins can set this value depending on the size of the E-Multi (EM1, EM2, for example).
13	Manual Cycle	<ul style="list-style-type: none"> Manual cycle can be used to enable or disable the individual pump activation and purging. Only the pump P1 will be operational. The pumps P2, P3 and P4 are disabled for the EM3 by default.

Section 5 - Components

This chapter provides information about the components of the Auto-Lube assembly and its connections.

5.1 Specifications

The specifications of the Auto-Lube system are the same for both the horizontal and vertical orientations of the E-Multi.

Table 5-1 Specifications	
Category	Value
Temperature	-20°C to 70°C
Maximum Pressure	70 bar (-10% or 15%)
Input voltage	24 V-DC ± 10%
Rated current	$I_{max} < 0.35 \text{ A}$ $I_{rest} < 0.05 \text{ A}$
Protection class	IP65
Fuse	1 A - delayed action

5.2 Orientation of Auto-Lube System for a Horizontal E-Multi

The following information is about the orientation of the Auto-Lube system for a horizontal E-Multi.



CAUTION

The Auto-Lube pump must always be vertical.

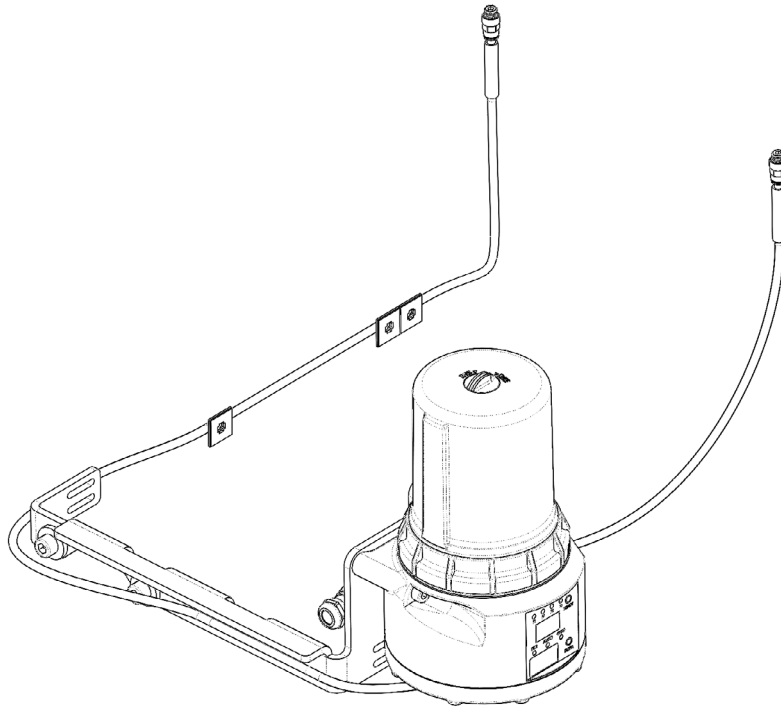

Figure 5-1 Orientation of Auto-Lube system for a horizontal E-Multi

5.3 Orientation of the Auto-Lube System for a Vertical E-Multi

The following information is about the orientation of the Auto-Lube system for a vertical E-Multi.

**CAUTION**

The Auto-Lube pump must always be vertical.

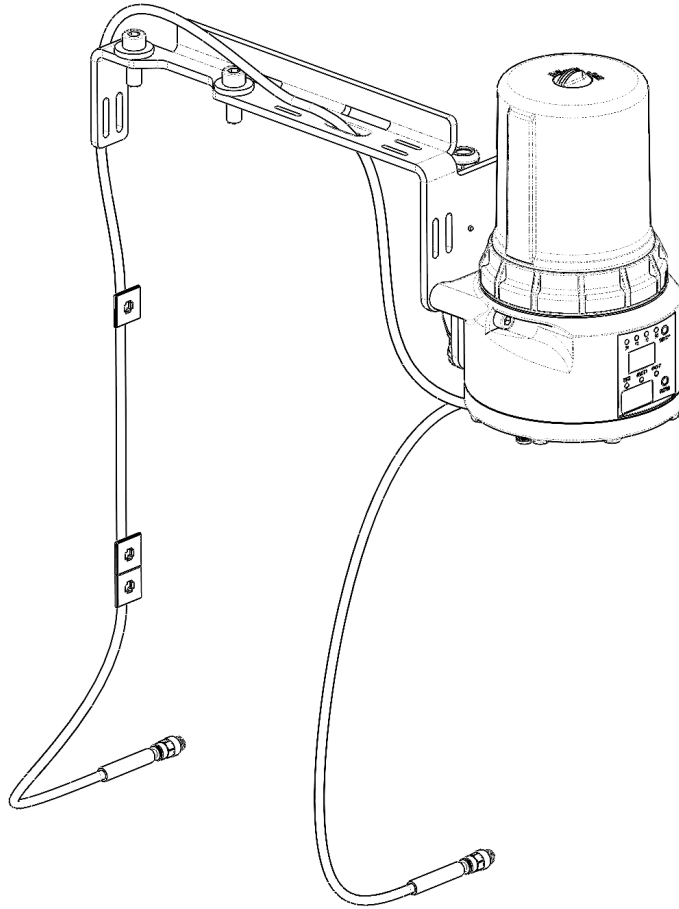

Figure 5-2 Orientation of Auto-Lube system for a vertical E-Multi

Section 6 - Installation

6.1 Material Handling

6.1.1 Inspection

Do the tasks that follow before you install the Auto-Lube unit.

1. Do a check for damage of the Auto-Lube unit.
2. Do a check for lubrication leakage in the Auto-Lube system.

6.2 Transport and Storage

6.2.1 Packaging

- The Auto-Lube unit with lubricant cartridge and other accessories is delivered in a cardboard box. The Auto-Lube unit and its components are covered with a plastic sheet to give protection from moisture and dirt.
- Obey national and company regulations when you discard the packaging materials.
- When you receive the Auto-Lube unit, check the delivery note to make sure that the delivered components are correct.
- If the component is damaged or missing, send a report immediately to the forwarding agent, insurance company, or Mold-Masters.

6.2.2 Transport



CAUTION

Be careful when you transport the Auto-Lube unit. Shocks can damage the Auto-Lube system.

- Do not throw the Auto-Lube system.
 - Keep the Auto-Lube in the correct position.
 - Make sure that you use the correct lifting equipment with a sufficient load capacity.
 - Obey the safety guidelines when you transport the system.
- ### 6.2.3 Storage
- For protection from corrosion, the Auto-Lube system must be stored in its original packaging in a cool and dry place at an ambient temperature of 5°C to 30°C.
 - The maximum storage time for the Auto-Lube system in its original packaging is two years.
 - Mold-Masters recommends the "first in, first out" principle for lubricant storage and use.

6.3 Electrical Connections



WARNING

Only approved electrical personnel should do the electrical installation.

6.3.1 E-Multi controller

Connect the wires from the E-Multi controller to the 8-pin female connector as shown in the table that follows.



CAUTION

- Make sure you install the correct polarity when you install pin 5.
- When you connect pin 6, install relay CR-LUBE "AIUE0000323" in the circuit.

Table 6-1 E-Multi Controller Connections			
Connection	From (DM272 I/O module)	Wire	To (8-pin female connector)
Error output signal from the Auto-Lube pump	DI0	AIUE0000077A-AWG18, blue	Pin 4
DC 24 V	DI1	AIUE0000077A-AWG18, blue	Pin 5
Pulse signal for activation	DI2	AIUE0000077A-AWG18, blue	Pin 6
COM	DI3	AIUE0000312-AWG-18, blue/white	Pin 7

1. Connect pin 8 from the female connector to ground with the wire "AIUE0000077A-AWG18, blue".
2. Connect the control relay for lube pump operation (CR-LUBE) to DO0 of the DM272 I/O module.



NOTE

Pins 1, 2, and 3 of the 8-pin female connector are only for future use.

6.3.2 Auto-Lube pump

Connect the wires from the 4 -pin female connector on the Auto-Lube pump to the 8-pin male connector as shown in the table that follows.



CAUTION

Make sure you install the correct polarity when you install pin 5.



NOTE

Pin 1, pin 2, pin 3, and pin 8 on the 8-pin male connector are only for future use.

Table 6-2 Auto-Lube Pump Connections			
Connection	From (Auto-Lube pump wire)	Wire	To (8-pin male connector)
DC 24 V	Pin 1	Brown	Pin 5
Input signal - pulse control	Pin 2	White	Pin 6
COM	Pin 3	Blue	Pin 7
Error output signal from the Auto-Lube pump	Pin 4	Black	Pin 4

6.3.3 Extension cable

1. Cut the 8-pin extension cable to the necessary length.
2. Connect one end of the 8-pin extension cable to the 8-pin male connector.
3. Connect the other end of the 8-pin extension cable to the 8-pin female connector.



NOTE

- The extension cable connects the 8-pin male connector on the Auto-Lube pump and the 8-pin female connector on the E-Multi controller.
- Make sure you use the “AIUE000151 - OLFLEX 18 AWG 9 conductor tray II cable” wire for the extension cable.

4. Connect the 8-pin male connector on the extension cable to the 8-pin female connector on the E-Multi controller.
5. Connect the 8-pin female connector on the extension cable to the 8-pin male connector on the Auto-Lube pump.

6.3.4 Connecting the power/data cable

1. Connect the 4-pin male power/data cable to the 4-pin female port on the Auto-Lube pump.

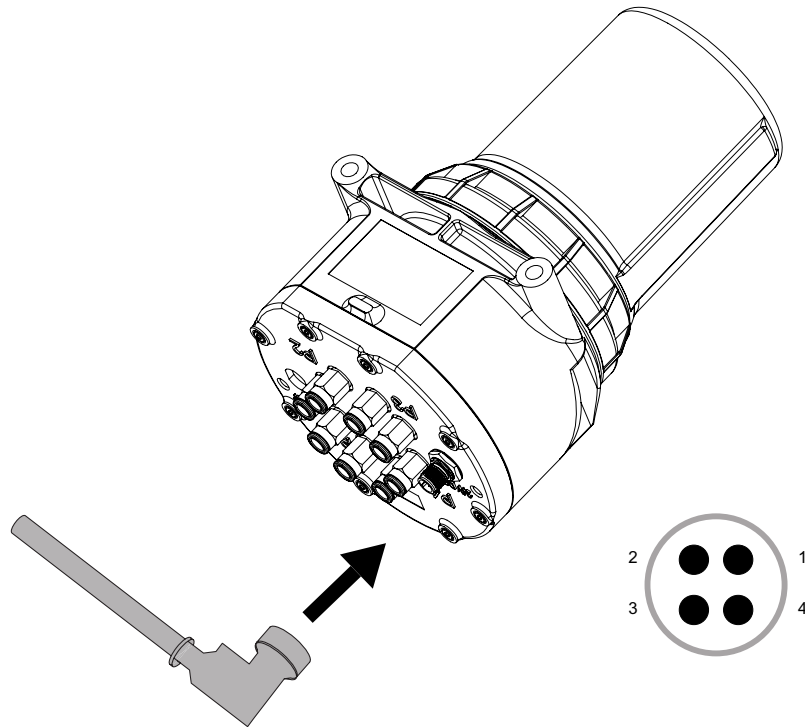
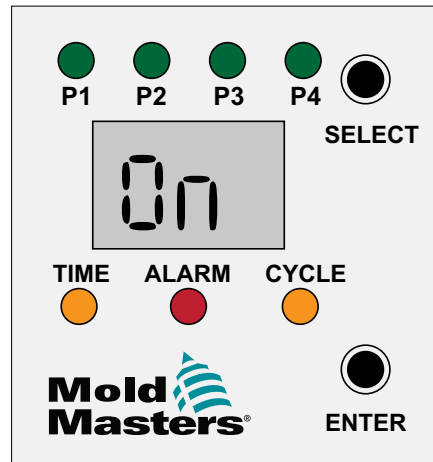

Figure 6-1 Connecting the power/data cable

6.3.5 Changing the operating mode to pulse control

The Auto-Lube pump will operate in time control mode by default. Do the procedure that follows to change the operation mode to pulse control.

1. When power is connected, the LCD of the Auto-Lube pump will show "On".



2. Press the SELECT button two times to go to programming mode ("Pro")

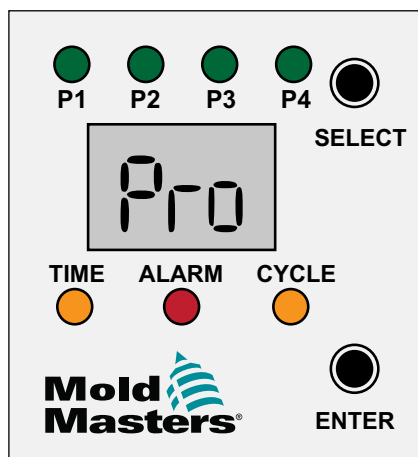
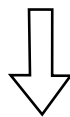
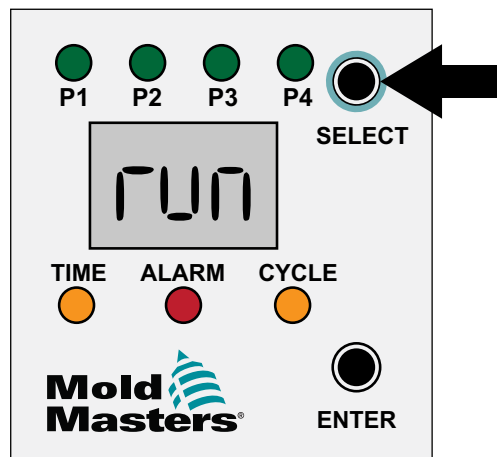
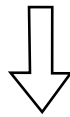
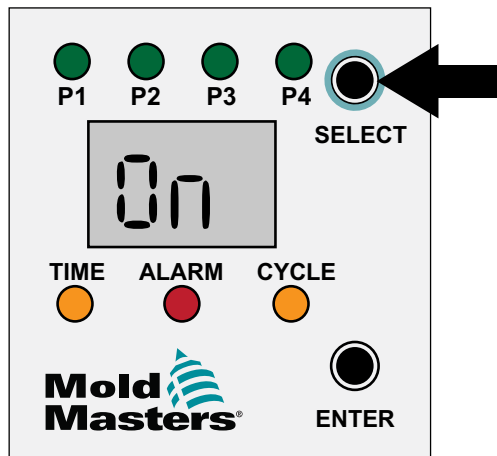

3. Press the ENTER button to confirm the selected mode ("Pro").



NOTE

Programming mode is protected by a pin. You must enter the pin to use programming mode. The default pin is "000".

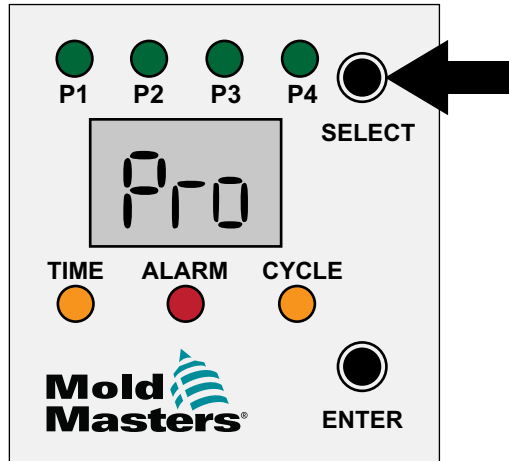

The LCD will show "Pin".

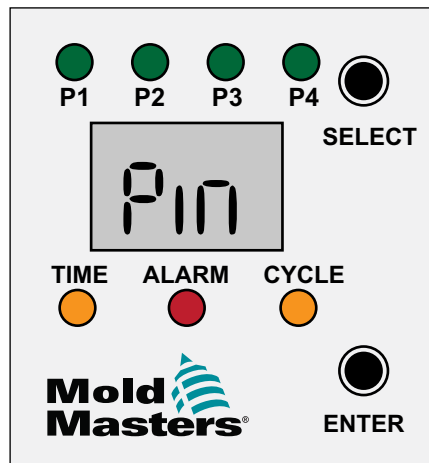

4. Press the SELECT button to enter the last digit of the pin (usually 3).

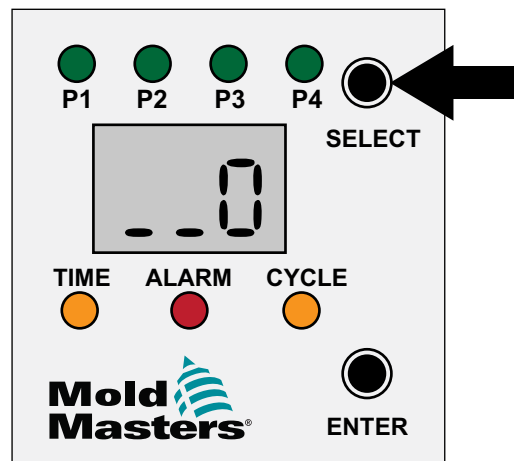

5. Press ENTER to confirm the last digit of the pin.

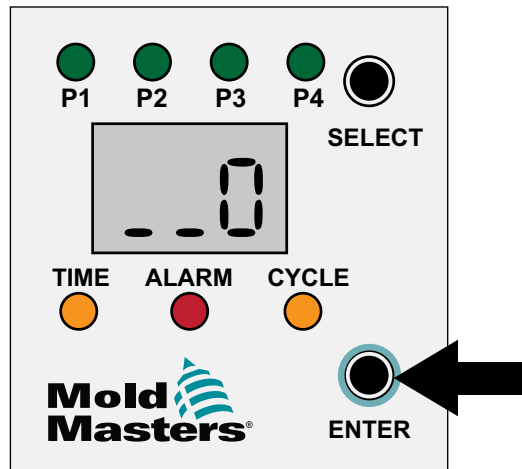

6. Press the SELECT button to enter the second digit of the pin (usually 2).

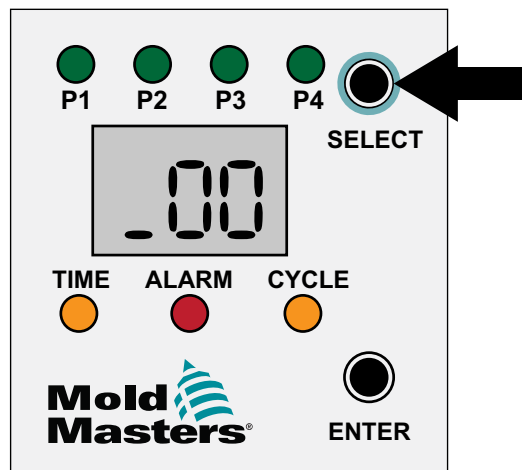

7. Press ENTER to confirm the second digit of the pin.

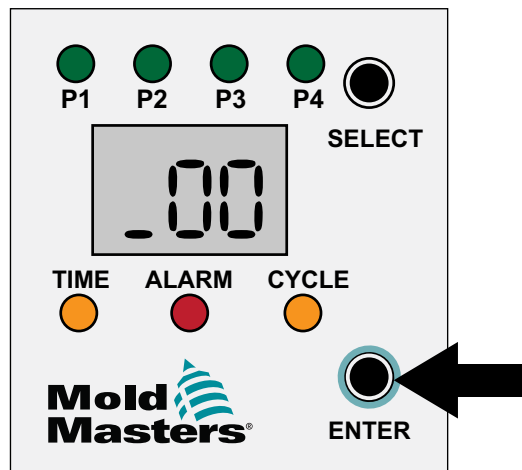

8. Press the SELECT button to enter the first digit of the pin (usually 1).

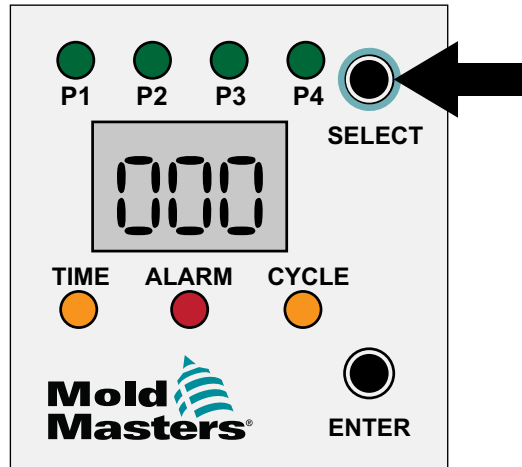

9. Press ENTER to confirm the first digit of the pin.

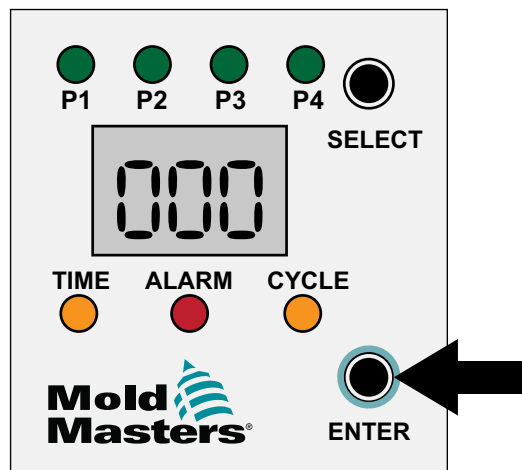

You can now operate the Auto-Lube pump in programming mode.

10. Press the SELECT button multiple times until the LCD shows "PuO".

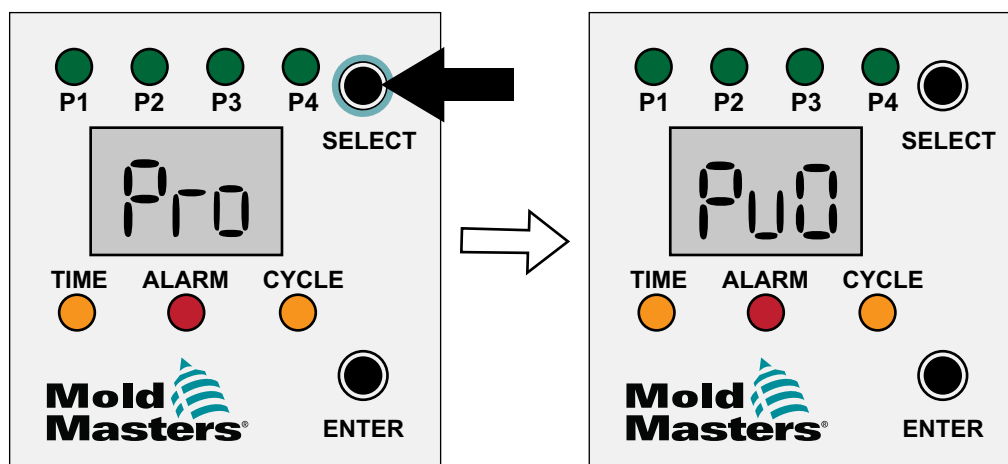

11. Press the ENTER button to change the operating mode.

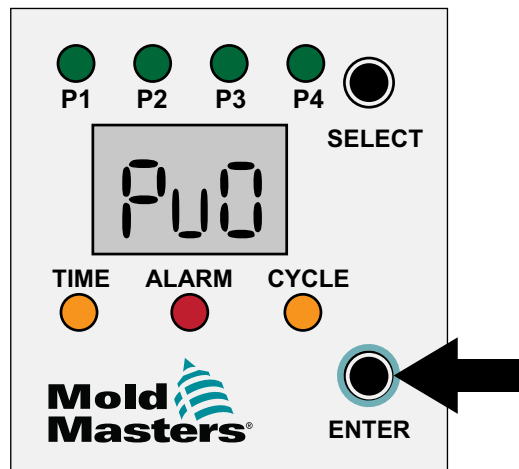

12. Press the SELECT button.

The LCD will show "Pul" (pulse control mode).

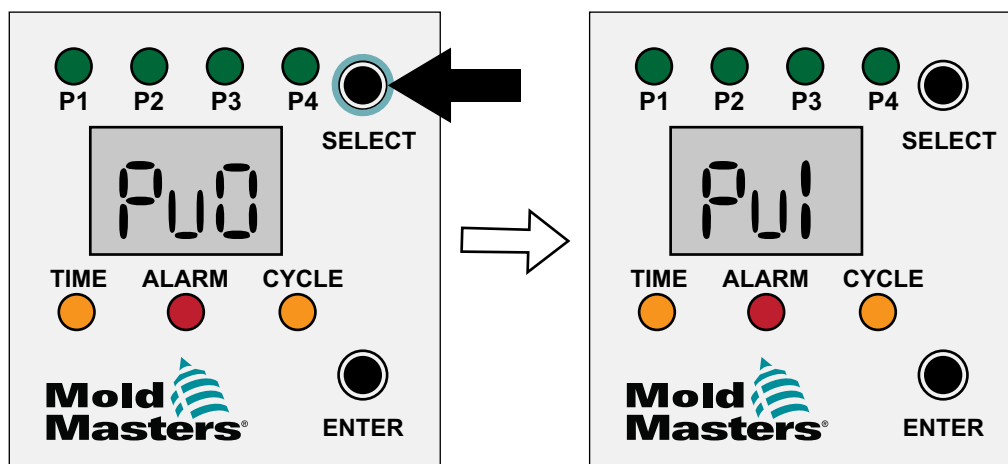

13. Press the ENTER button to confirm the change of operating mode to pulse control.



NOTE

After pulse control mode is selected, the activated pump bodies will be shown by the pump body LEDs on the control panel.

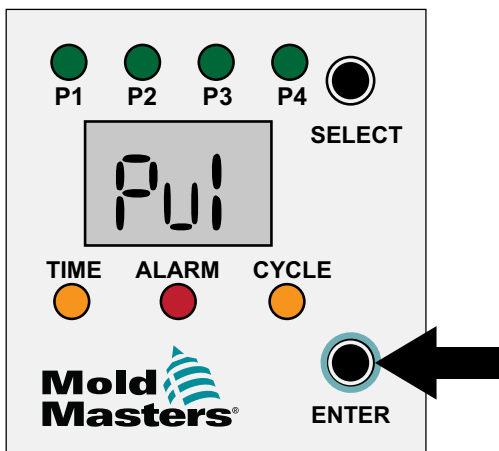

The LCD will show "PAU" (pause) which shows that the operating mode is pulse control. "PAU" shows that the Auto-Lube pump is in pulse control mode and is waiting for control signals from the E-Multi controller.

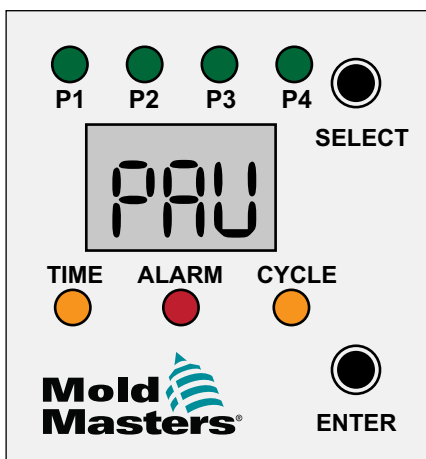

14. Press the SELECT button until "Pro" is shown.

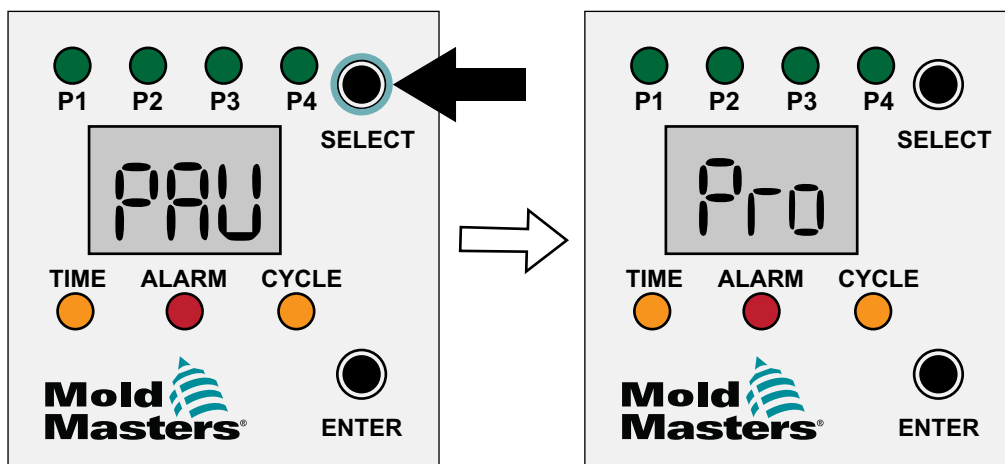

15. Press the ENTER button to confirm the selected mode "Pro"

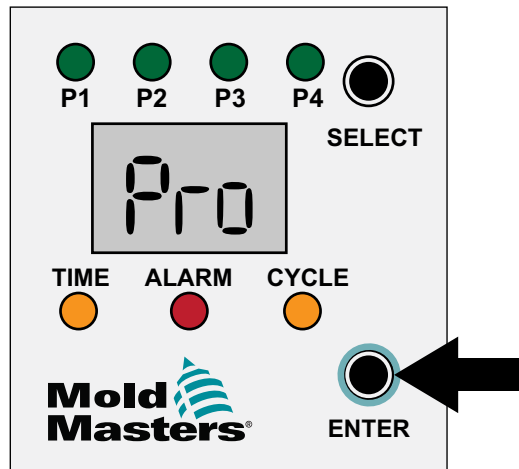

16. Press the SELECT button multiple times until the LCD shows "ESC".

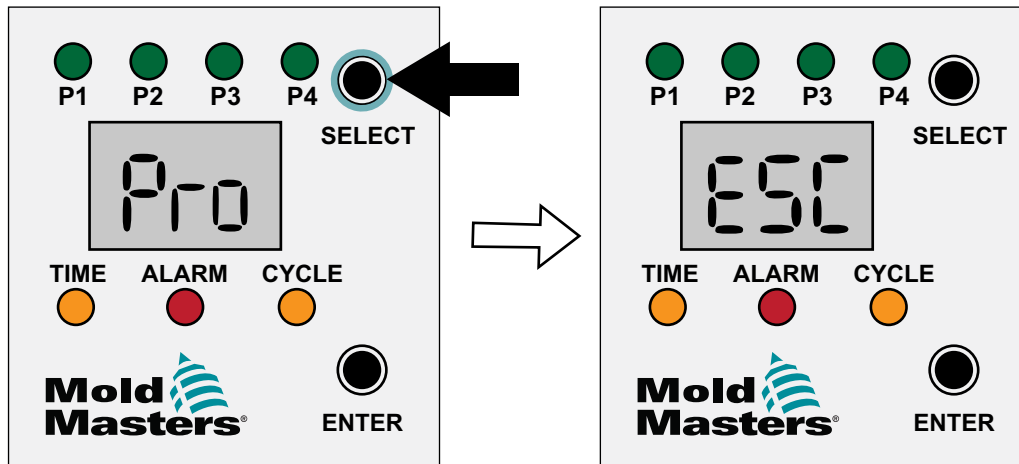

17. Press the ENTER button to confirm the selection "ESC".

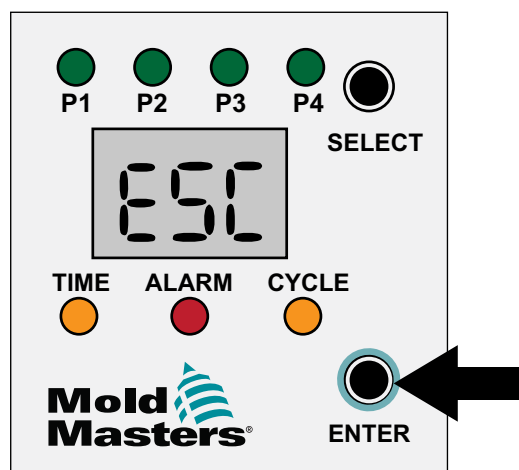

The LCD will show "On". The Auto-Lube pump is in pulse control mode.

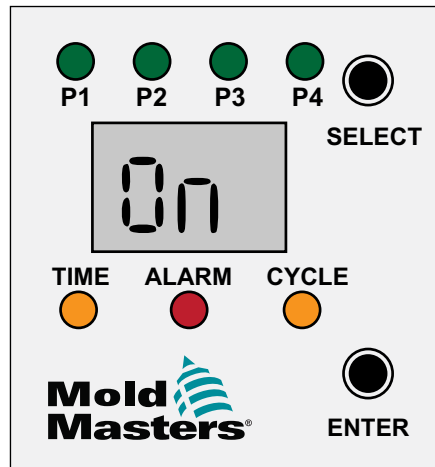

Section 7 - Operation

7.1 Activation Key

IMPORTANT

Do not lose the activation key.

The activation key is installed on the top of the Auto-Lube pump. The activation key must be installed during the first installation of the Auto-Lube pump.

The activation key is a magnetic switch that operates based on inputs received from the E-Multi touchscreen. When the Auto-Lube pump motor is operating, the activation key will not respond to inputs from the E-Multi touchscreen.

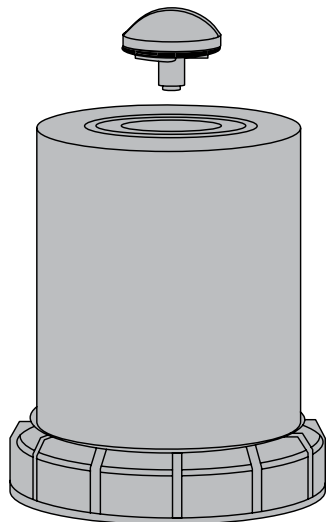
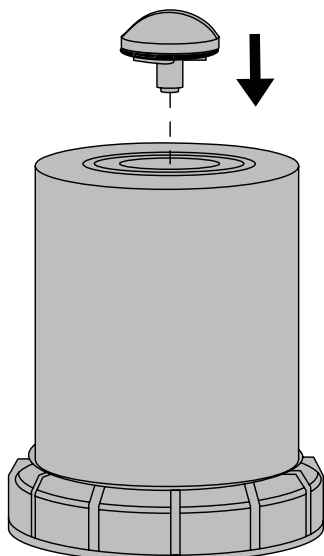

Figure 7-1 Activation key

7.1.1 Installing the activation key

1. Install the activation key in the slot on top of the Auto-Lube pump.



2. Rotate the activation key in the clockwise direction.

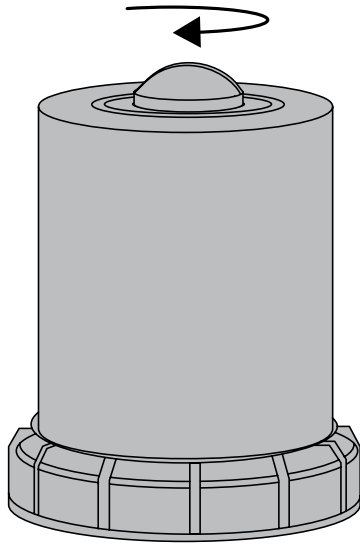

7.1.2 Removing the activation key

1. Rotate the activation key in the counterclockwise direction.

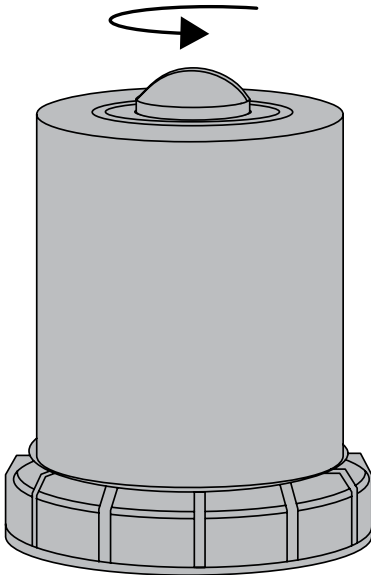

2. Remove the activation key from the slot on the top of the Auto-Lube pump.

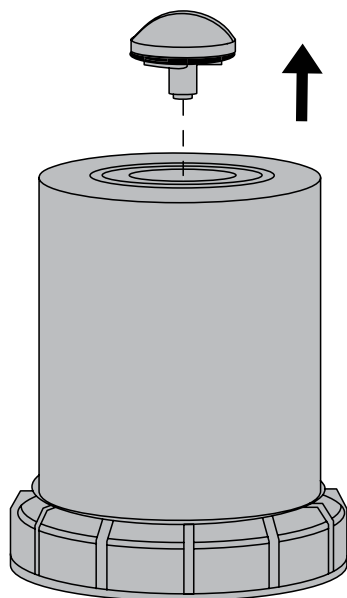

7.2 Priming the Auto-Lube system

This procedure must be done:

- At the time of commissioning the Auto-Lube system.
- After the lubrication cartridge is replaced.

After you complete the electrical connections, you must bleed the Auto-Lube system to remove air from the Auto-Lube system and to ensure smooth operation of the Auto-Lube system. Do the procedure that follows to bleed the Auto-Lube system.



NOTE

- The Auto-Lube pump has a built-in 40 second delay between the priming cycles.
- The pump body LED indicates the pump in which the priming is currently active.
- The pump outlet in which priming is active is shown in the control panel display.

All grease lines must be manually filled and primed with a grease gun prior to starting Auto-Lube pump priming procedure. Use PRO mode to manually purge individual lines if necessary; refer to *Section 6.3.5 Changing the operating mode to pulse control on page 6-5*.

If you are priming after replacing the lubrication cartridge, remove the lines at the pump and verify that lubrication flows through ports before priming the lines.

1. Select the "Enable Priming" checkbox on the E-Multi touchscreen.

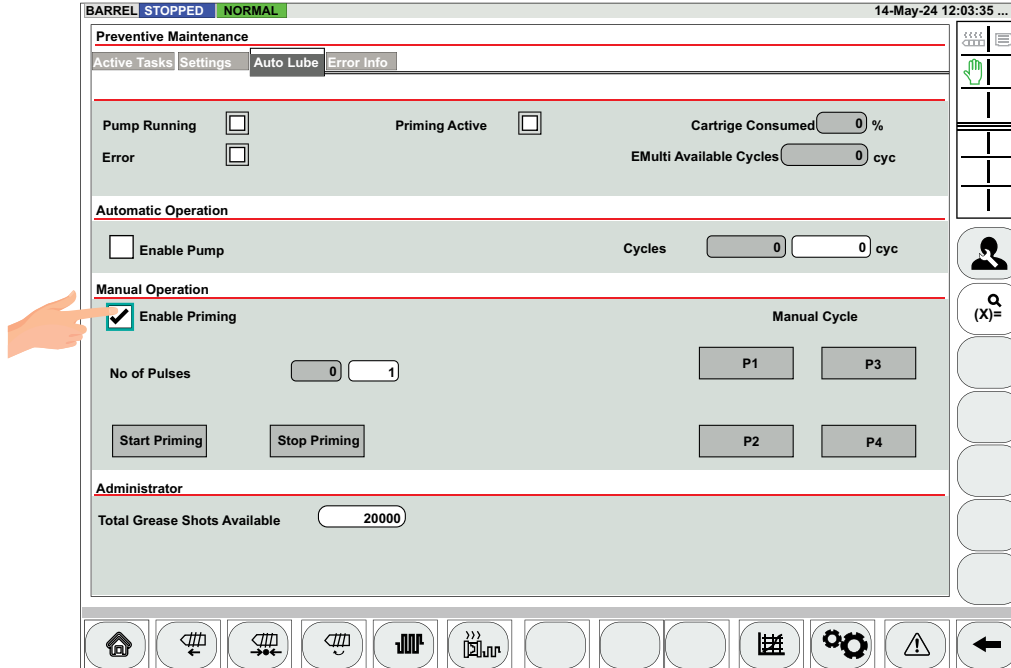

2. Select the "Start Priming" button on the E-Multi touchscreen.

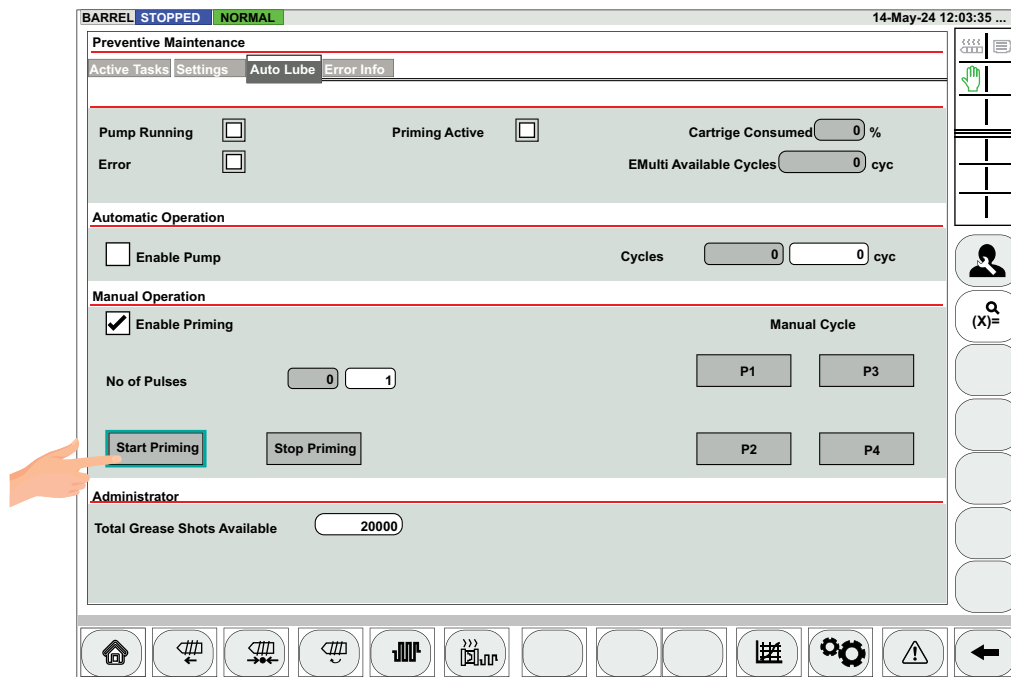

"Priming Active" will be displayed on the E-Multi touchscreen. The Auto-Lube pump is in priming mode.

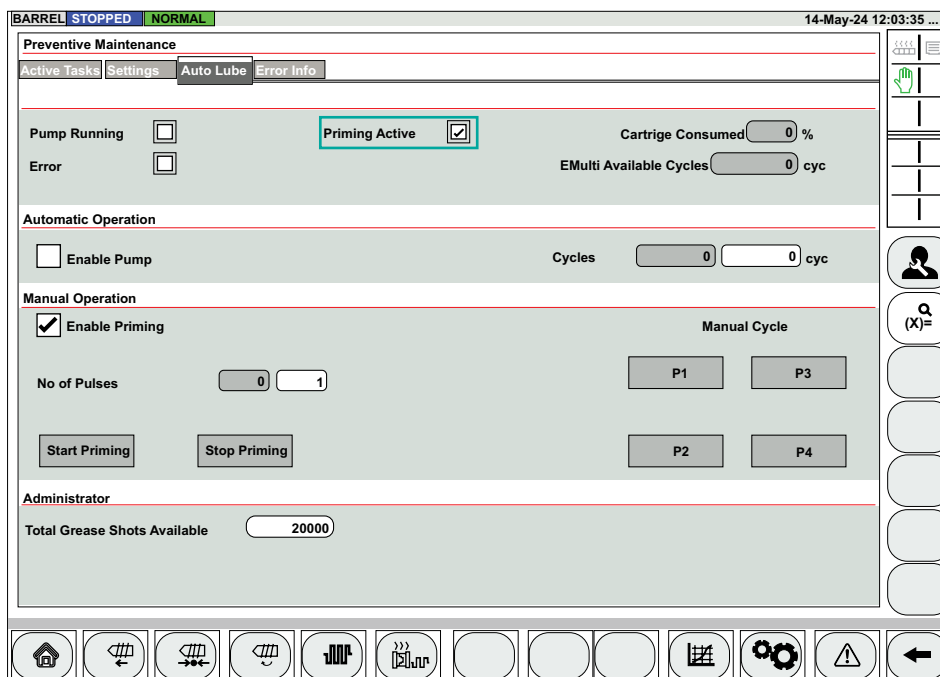

7.2.1 Stopping the priming of the Auto-Lube system

1. Press the "Stop Priming" button to stop the priming of the Auto-Lube system.

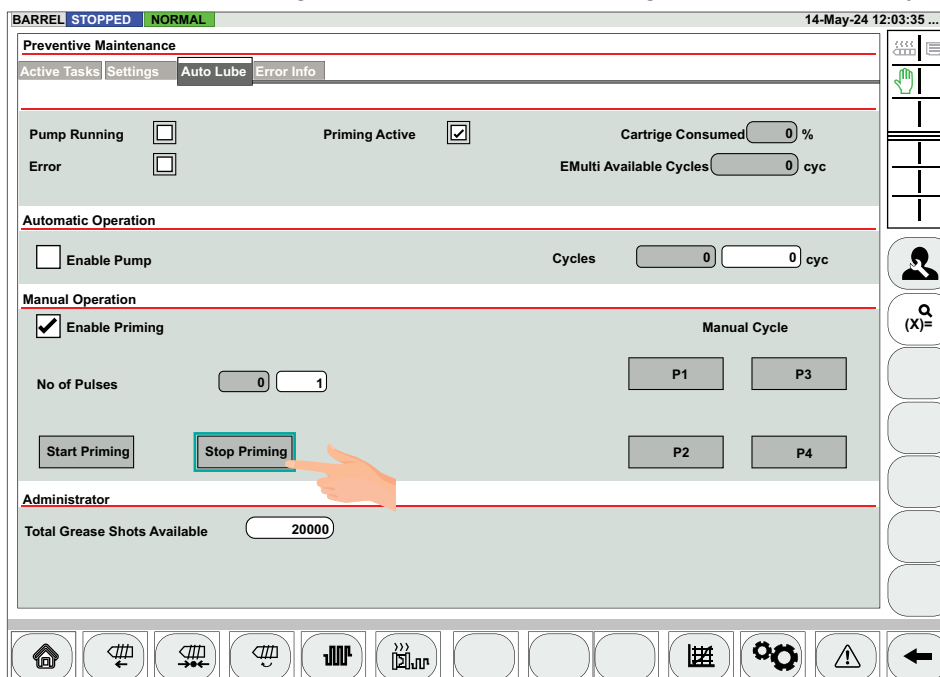

Section 8 - Maintenance

8.1 Maintenance Schedule



DANGER

Do not disconnect a protective device. Only approved personnel can disconnect a protective device.



CAUTION

The lubrication cartridge must be replaced once a year.

Make sure that you have read *Section Section 3 Safety Information* before you do maintenance work on the Auto-Lube system.

Maintenance must be done as detailed in the table that follows.

Table 8-1 Maintenance Schedule			
Procedure	Maintenance Schedule		
	At the time of installation	After 3 months or 500 hours of operation	Once per year
Visual inspection	Yes	Yes	Yes
Clean the system	Yes	Yes	Yes
Cartridge replacement	Yes	Not required	Yes

If necessary, do the maintenance procedures before the recommended time.

8.1.1 Visual inspection

Do the visual inspection procedure that follows.

- Inspect the components of the Auto-Lube system for external damage.
- Inspect the lubrication point to make sure that the lubricant supply is correct.
- Inspect the lubrication level in the lubrication cartridge.
- Inspect the lubricated components. If there is too much or too little lubrication on the ball screws, contact Mold-Masters.
- Correct error messages in the Auto-Lube system.
- Replace defective parts immediately.

8.1.2 Cleaning the Auto-Lube system



CAUTION

Do not use compressed air to clean the Auto-Lube system. Compressed air can damage the Auto-Lube system and contaminate the lubricant.

Only use approved cleaning agents to clean the Auto-Lube system. Some approved cleaning agents are:

- Absorbent towels
- Cloths

8.1.3 Replacing the lubrication cartridge

- Make sure that you use only manufacturer approved lubrication.
- Use of lubrication other than manufacturer approved lubrication can cause failure and lead to breakdown of the machine. Mold-Masters recommends that you maintain a sufficient inventory of lubrication.

8.1.3.1 Removing the lubrication cartridge



WARNING

Be careful when you remove the upper housing. The upper housing is spring-loaded. Parts in the spring load can cause injury when removed.

1. Rotate the retaining ring in the counterclockwise direction.

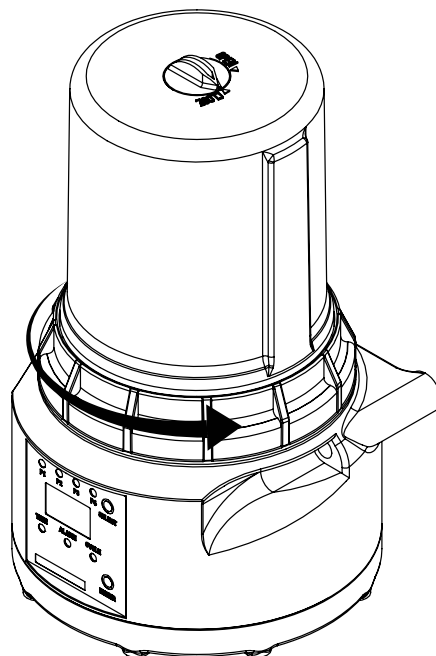

2. Pull up and remove the upper housing.

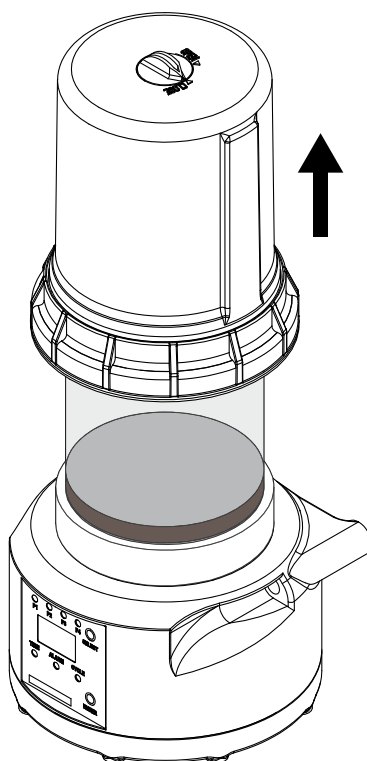

3. Rotate the lubrication cartridge in the counterclockwise direction

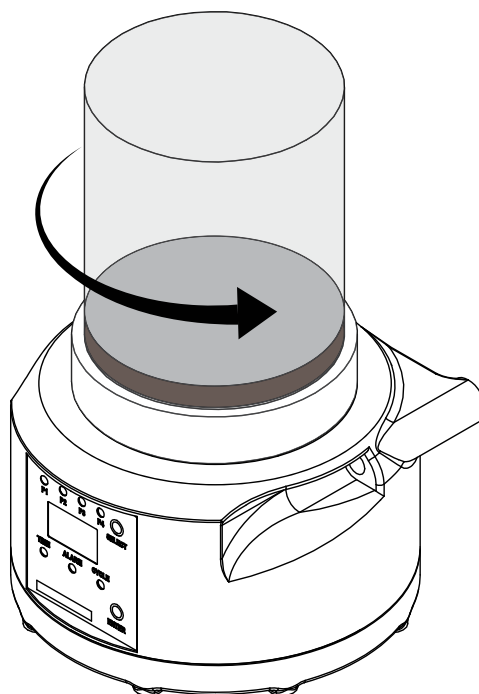

4. Pull up and remove the lubrication cartridge.

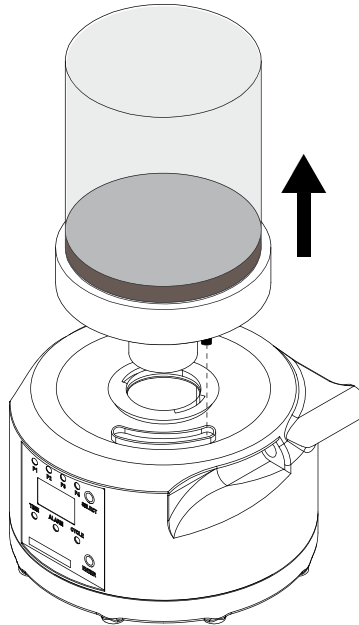

8.1.3.2 Installing a lubrication cartridge



CAUTION

Failure to use a spatula to guide the lubrication into the Auto-Lube pump can cause the Auto-Lube system to malfunction.

1. Push the piston of the lubrication cartridge to fill the Auto-Lube pump with lubrication.
To minimize air pockets in the Auto-Lube system, use a spatula to guide the lubrication into the Auto-Lube pump.



NOTE

The procedure that follows only applies to the first installation of the lubrication cartridge.

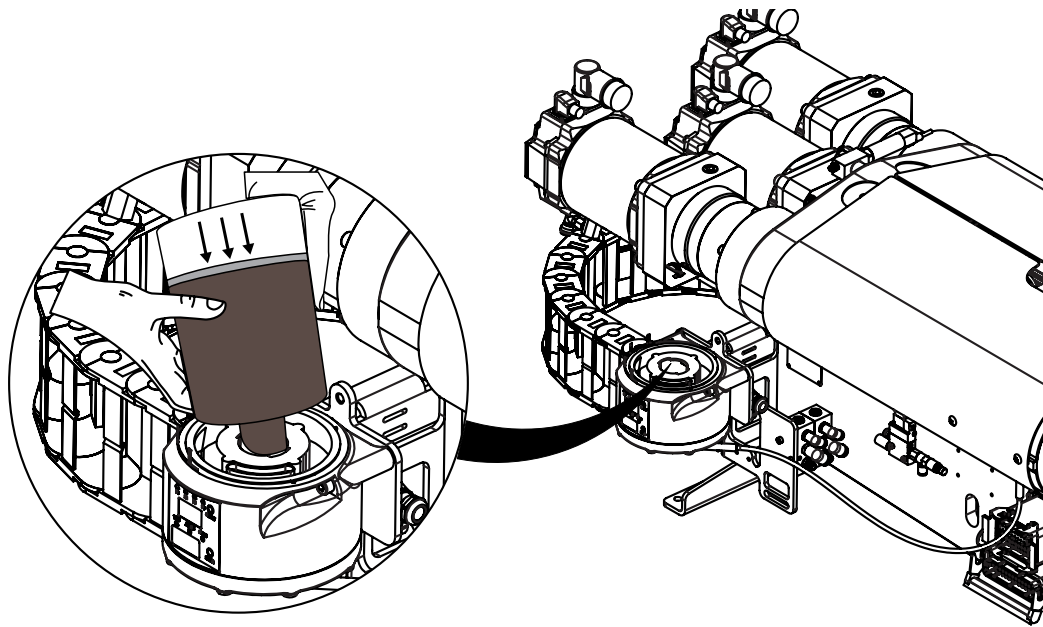
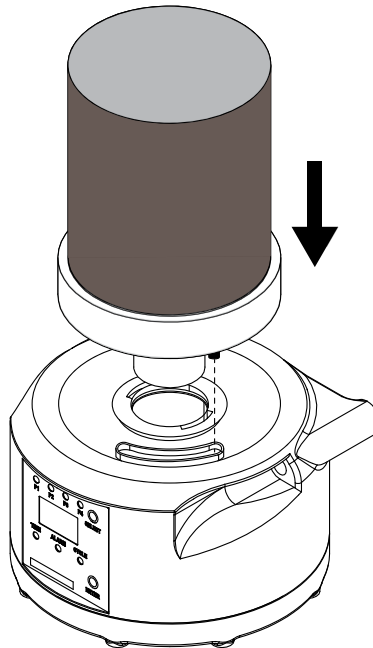

Figure 8-1 Installing a lubrication cartridge

2. Remove the protective cap from the lubrication cartridge.
3. Fill the pump cavity with lubrication to eliminate air bubbles. Failure to do so may prevent lubrication from being pumped.



4. Squeeze the lubrication cartridge until lubricant comes out of port.
5. Insert a new lubrication cartridge in the slot on the Auto-Lube pump.

6. Rotate the lubrication cartridge a quarter turn in the clockwise direction.

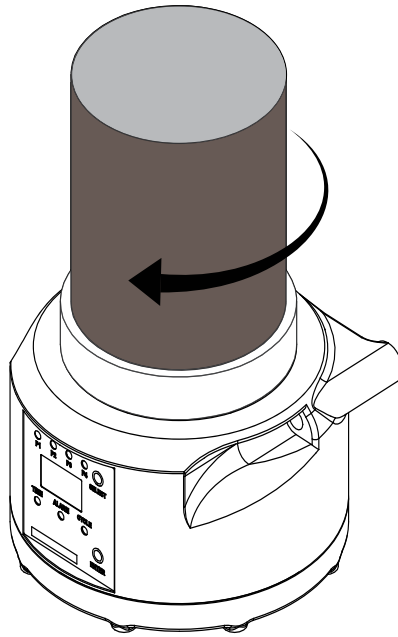

7. Install the upper housing over the lubrication cartridge.

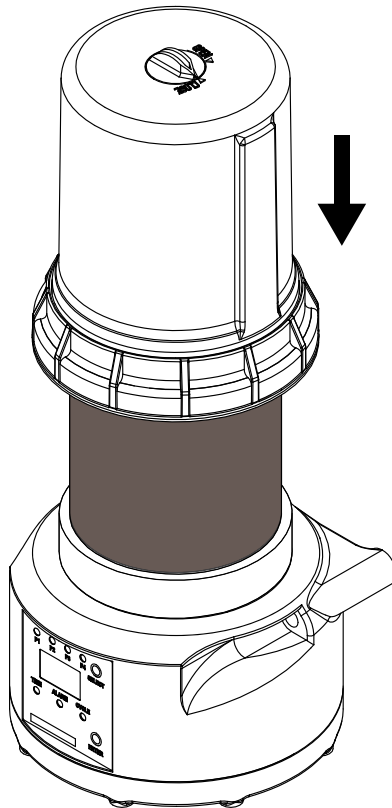

8. Rotate the retaining ring in the clockwise direction to lock the upper housing to the Auto-Lube pump.

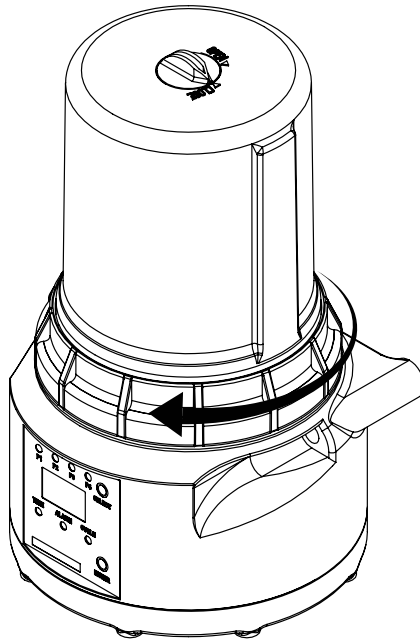

Do the steps in *Section 7.2 Priming the Auto-Lube system on page 7-3.*

8.1.4 Filling a lubrication cartridge



WARNING

Excess pressure can make the lubrication cartridge explode. Stop the cartridge refill procedure once the follower piston reaches the top.



CAUTION

Dust can damage the Auto-Lube system. Make sure you do the cartridge refill procedure in a dust free environment.



CAUTION

Air present in the lubrication cartridge can cause insufficient lubricant supply. Remove any air from the lubrication cartridge.



CAUTION

Filling the lubrication cartridge incorrectly or using an alternative lubrication will invalidate the warranty.



NOTE

Use a manual drum pump to add lubrication to the lubrication cartridge. Contact Mold-Masters to get the filling adapter.

1. Remove the lubrication cartridge from the Auto-Lube pump. Refer to *Section 8.1.3.1 Removing the lubrication cartridge*.
2. Install the filling adapter on the port of the manual drum pump.

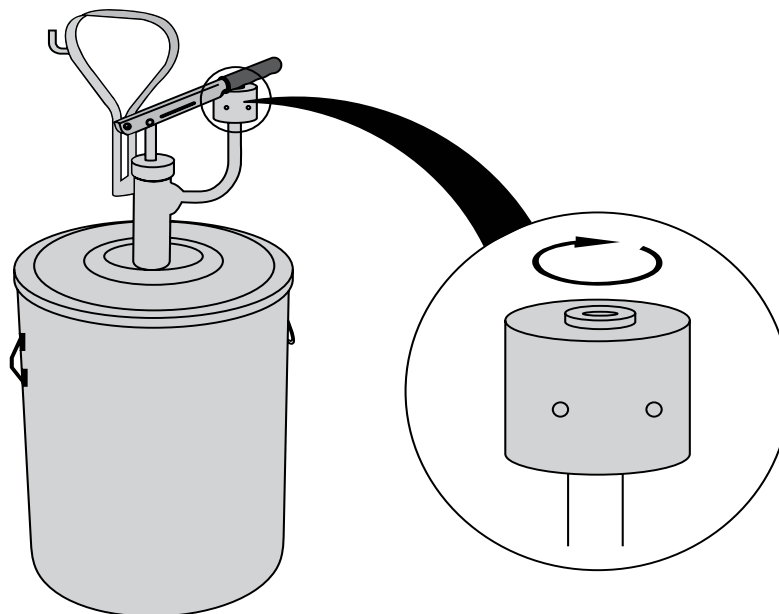

3. Push the follower piston to the bottom of lubrication cartridge.

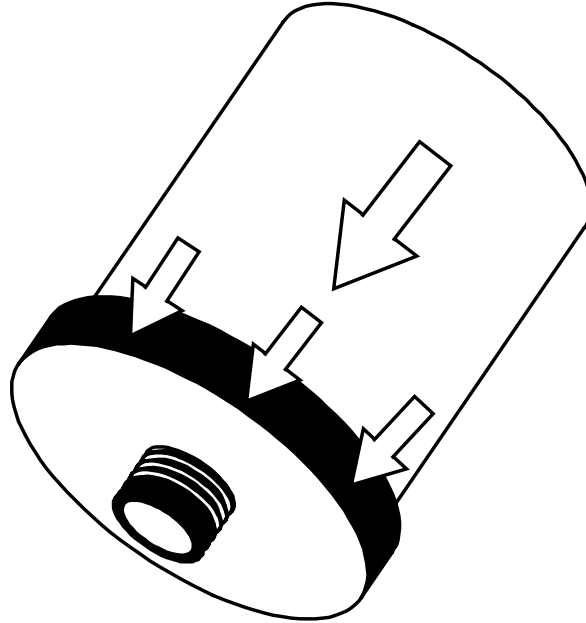

4. Install the lubrication cartridge on the filling adapter.

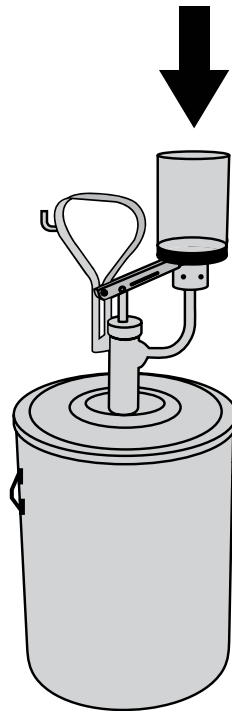

5. Use the handle of the manual drum pump to pump lubrication into the lubrication cartridge.

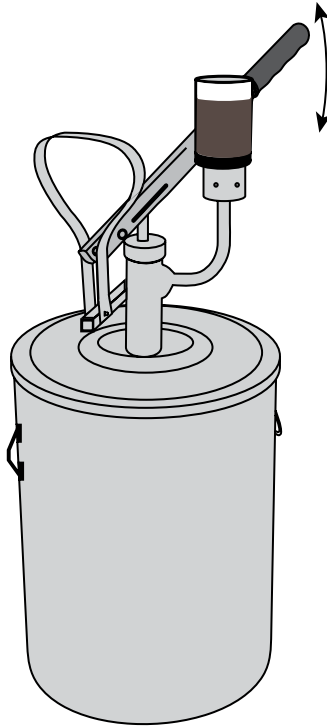

6. Stop the fill procedure when the follower piston reaches the top of the lubrication cartridge.

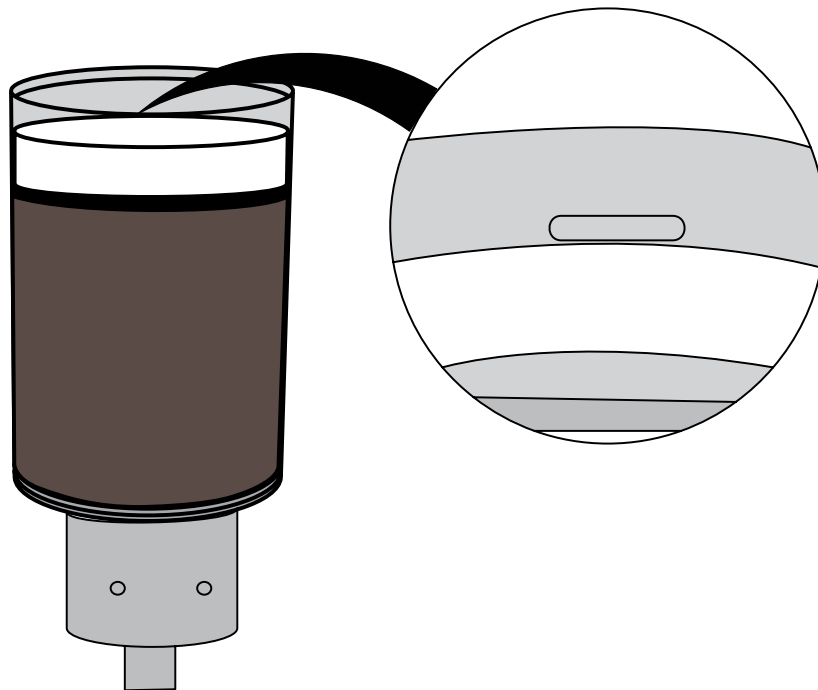

7. Pull up and remove the lubrication cartridge from the filling adapter.

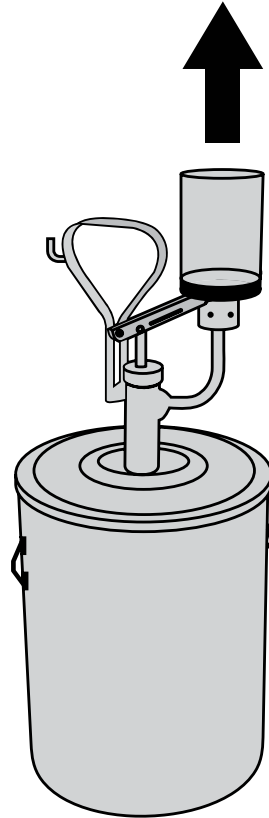

8. Install the cap on the lubrication cartridge.

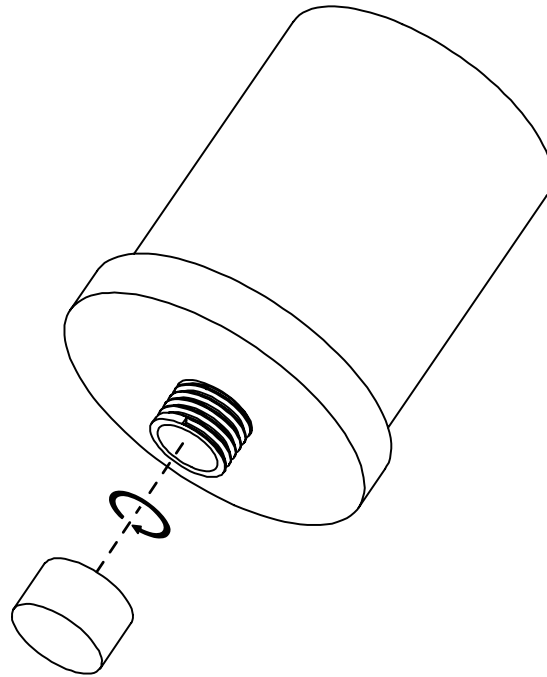

9. Press the sides of the follower piston to remove the air cushion.

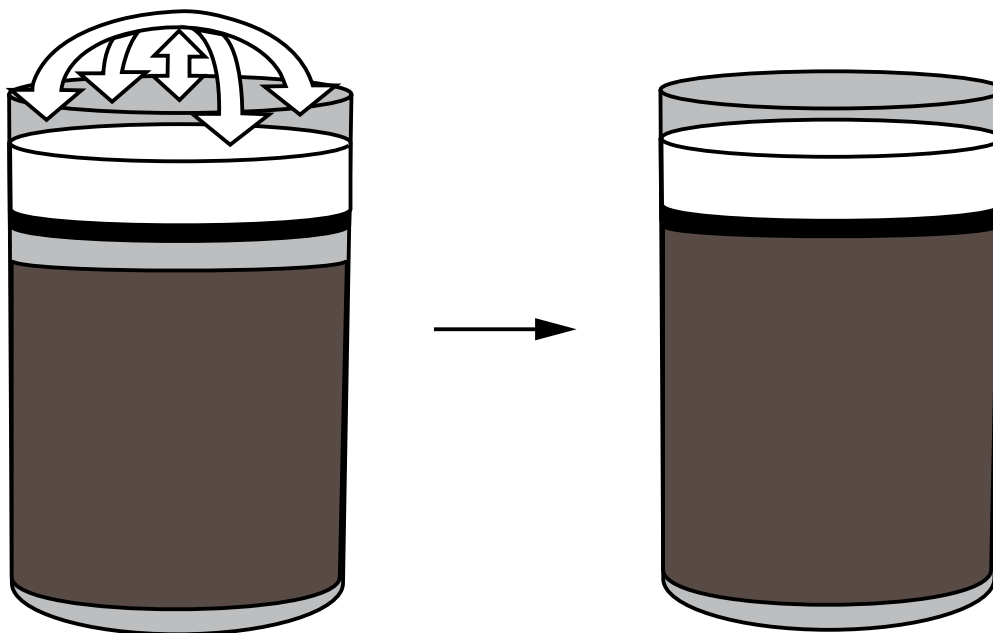

10. Write the lubrication specifications on the label of the lubrication cartridge.

8.1.5 Decommissioning

Do the instructions that follow when you remove the Auto-Lube system from the injection unit.

- Make sure that the machine is not in operation.
- Disconnect and lock out the electrical system.
- Make sure that the lubricant pipes are not pressurized.

8.1.6 Recommissioning

Do the instructions that follow when you re-install the Auto-Lube pump in the injection unit.

- Install the necessary safety devices.
- Make sure that there are no tools in the operation zone.
- Connect the power/data cable to the Auto-Lube system.
- Inspect the operation of the Auto-Lube pump.

Section 9 - Troubleshooting

This chapter gives information about the error messages that are displayed on the LCD of the Auto-Lube pump and procedures to correct the errors. The LEDs (P1, P2, P3, P4) on the control panel of the Auto-Lube pump show which pump has an error.

Table 9-1 Error Messages	
Error	Description
E1	Lubrication cartridge is empty.
E2	Lubrication cartridge is not approved.
E3	Low voltage
E4	Internal electrical problem
E7	Back pressure is greater than the limit.

9.1.1 Error E1



NOTE

The error message “E1” will be cleared automatically when the lubrication cartridge is replaced.

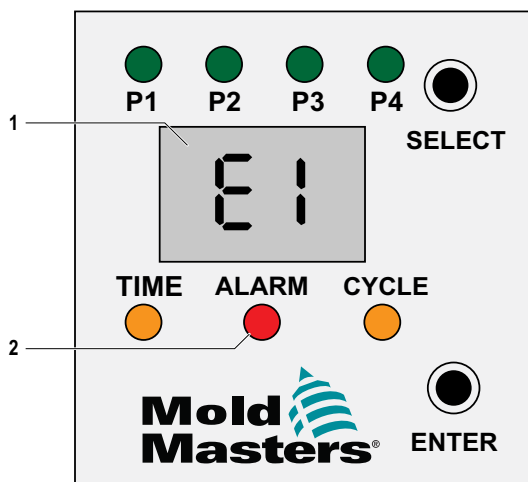

Figure 9-1 Error E1

Refer to the table that follows for information about the error E1.

Table 9-2 Error E1			
Error	Event	Possible Problem	Remedy
E1 (1)	<ul style="list-style-type: none"> The ALARM LED is illuminated. (2) The output signal at PIN 4 = LOW (0 V) (2). The operation of all pump bodies is stopped. 	The lubrication cartridge is empty.	<ul style="list-style-type: none"> Replace with new lubrication cartridge approved by the manufacturer. Refer to section <i>Section 8.1.3 Replacing the lubrication cartridge.</i>

9.1.2 Error E2



NOTE

The error message “E2” will be cleared automatically when a manufacturer-approved lubrication cartridge is installed.

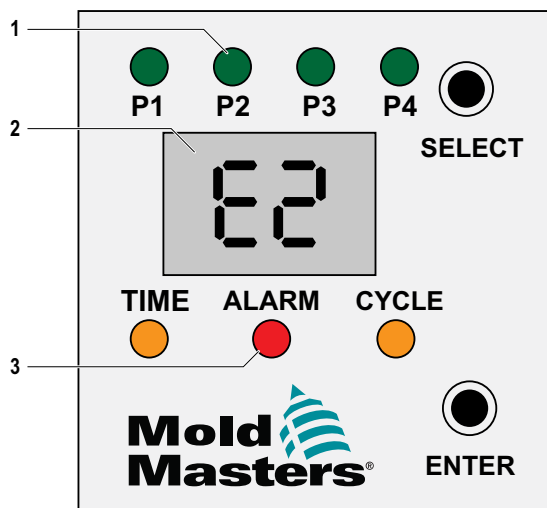

Figure 9-2 Error E2

Refer to the table that follows for information about the error E2.

Table 9-3 Error E2			
Error	Event	Possible Problem	Remedy
E2 (2)	<ul style="list-style-type: none"> The ALARM LED is illuminated (3). The output signal at PIN 4 = LOW (0 V) The operation of all pump bodies (1) is stopped. 	The lubrication cartridge is not approved by the manufacturer.	<ol style="list-style-type: none"> Replace the lubrication cartridge with a new lubrication cartridge approved by the manufacturer. Do the steps in <i>section Section 8.1.3 Replacing the lubrication cartridge.</i>

9.1.3 Error E3

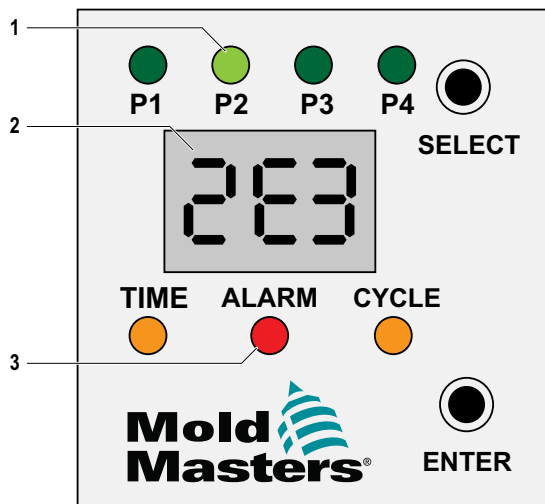

Figure 9-3 Error E3

The "2" in error message "2E3" shows that the error applies to pump body 2 (P2). Refer to the table that follows for further information about the error E3.

Table 9-4 Error E3			
Error	Event	Possible Problem	Remedy
2E3 (2)	<ul style="list-style-type: none"> The ALARM LED is illuminated (3). The output signal at PIN 4 = LOW (0 V) The LED of the affected pump body is illuminated in the control panel (in this example P2) (1). The operation of the affected pump body is stopped. 	The power supplied to the Auto-Lube pump is too low.	<ol style="list-style-type: none"> Use the control panel to put the Auto-Lube pump in programming mode ("PRO"). Use the function "Clr" to delete the error. If step 2 does not clear the error, disconnect the power/data cable for a short time. The pump will restart. If the error continues, inspect the power supplied to the pump.

9.1.4 Error E4

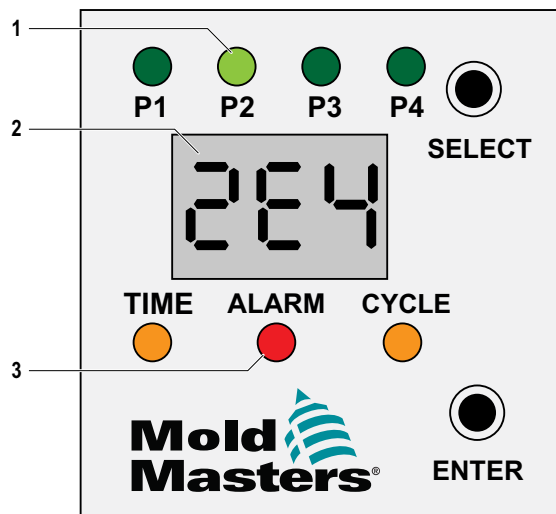

Figure 9-4 Error E4

The "2" in error message "2E4" shows that the error applies to pump body 2 (P2) Refer to the table that follows for further information about the error E4.

Table 9-5 Error E4			
Error	Event	Possible Problem	Remedy
2E4 (2)	<ul style="list-style-type: none"> The ALARM LED is illuminated (3). The output signal at PIN 4 = LOW (0 V). The LED of the affected pump body is illuminated in the control panel (in this example P2) (1). The operation of the affected pump body is stopped. 	Internal electrical problem	<ol style="list-style-type: none"> Use the control panel to put the Auto-Lube pump in programming mode ("PRO") . Use the function "Clr" to delete the error. If step 2 does not clear the error, disconnect the power/data cable for a short time. The pump will restart.

If the possible remedies listed in Table 9-5 Error E4 do not clear the error, contact Mold-Masters to get the Auto-Lube pump repaired.

9.1.5 Error E7

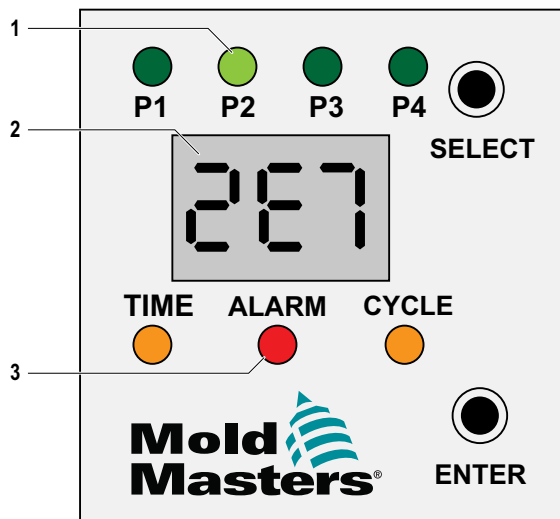

Figure 9-5 Error E7

The "2" in error message "2E7" shows that the error applies to pump body 2 (P2). Refer to the table that follows for further information about the error E7.

Table 9-6 Error E7			
Error	Event	Possible Problem	Remedy
2E7	<ul style="list-style-type: none"> The ALARM LED is illuminated (3). The output signal at PIN 4 = LOW (0 V) The LED of the affected pump body is illuminated in the control panel (in this example P2) (1). The operation of the affected pump body is stopped. 	<p>The back pressure is greater than the limit.</p> <p>Reasons that can cause high back pressure:</p> <ul style="list-style-type: none"> The lubrication point is blocked. The length of the lubricant hose is greater than the limit. The lubrication flow is not smooth. 	<ol style="list-style-type: none"> Find and repair the cause of the high back pressure. Use the control panel to put the Auto-Lube pump in programming mode ("PRO") . Use the function "Clr" to delete the error. If step 3 does not clear the error, disconnect the power/ data cable for a short time. <p>The pump will restart.</p>

If the possible remedies listed in Table 9-6 Error E7 do not clear the error, contact Mold-Masters to get the Auto-Lube pump repaired.

Section 10 - Service

For lubrication cartridge replacement, refer to *Section 8.1.3 Replacing the lubrication cartridge*.

Other than for cartridge replacement, the Auto-Lube unit should never be removed for maintenance. If the Auto-Lube unit must be removed or serviced, please contact your Mold-Masters representative.

10.1 Spare Parts

Contact your Mold-Masters representative if you need any spare parts for the Auto-Lube system.

Index

Symbols

2E3...9-3
2E4...9-4
2E7...9-5

A

activation key...7-1
 installing...7-1
 removing...7-2
Auto-Lube pump
 connections...6-3
 control panel...4-1
 errors...9-1
 operating conditions...5-1
 specifications...5-1
Auto-Lube system
 cleaning...8-2
 decommissioning...8-12
 introduction...1-1
 priming the...7-3
 recommissioning...8-12
 specifications...5-1
 stopping the priming of...7-5
 storage...6-1
 transporting...6-1
Auto-Lube touchscreen...4-3
available cycles
 E-Multi...4-4

C

cartridge. See lubrication cartridge
components
 horizontal orientation...5-2
 vertical orientation...5-3
control panel...4-1. See also Auto-Lube pump, control panel

D

drum pump
 manual...8-8

E

E1...9-1
E2...9-2
E3...9-3
E4...9-4
E7...9-5
electrical connections
 Auto-Lube pump...6-3

E-Multi controller...6-2
 extension cable...6-3
ENTER...4-1
errors. See lubrication pump, errors
ESC. See modes
extension cable. See electrical connections, extension cable

F

filling adapter...8-8
functions...4-2
fuse...5-1

I

installation...6-1

L

LEDs...4-1
lubricant
 recommended...
 safe use of...3-1
 use of...3-3
lubrication cartridge
 filling...8-8
 installing...8-4
 percentage used...4-4
 removing...8-2
 replacement schedule...8-1
 replacing...8-2

M

maintenance schedule...8-1
manual drum pump. See drum pump, manual mode
 time control...4-2, 6-5
modes...4-2

O

On. See modes
operating mode. See modes
 changing to pulse mode...6-5

P

P1, P2, P3, P4...4-1
PAU...6-11
personal protective equipment...3-1
Pin. See modes
power/data cable
 connecting...6-4

PPE...3-1

priming. See Auto-Lube system, priming the
priming, stopping the. See Auto-Lube system, stop-
ping the priming of

Pro. See modes

programming mode
accessing...6-7

R

Run. See modes

S

safety...3-1

SELECT...4-1

service...10-1

spare parts...10-1

specifications. See Auto-Lube system, specifications

storage. See Auto-Lube system, storage of

support...2-1

T

tools. See installation, tools

touchscreen

E-Multi...4-3

transport. See Auto-Lube system, transport

troubleshooting...9-1

U

UI. See user interface, Auto-Lube touchscreen;
See control panel

upper housing

removing...8-2

user interface

Auto-Lube touchscreen...4-3

control panel...4-1. See also Auto-Lube pump,
control panel

W

warning labels...3-1

warranty...1-2



Scan the QR code for our global contacts: