

# E-Multi<sup>®</sup> mini

User Manual

version 1



# Contents

<b>Section 1 - Introduction .....</b>	<b>1-1</b>
1.1 Intended Use .....	1-1
1.2 Documentation .....	1-1
1.2.1 Document Release Details .....	1-1
1.2.2 Document Conventions .....	1-1
1.3 Warranty .....	1-1
1.4 Returned Goods Policy.....	1-1
1.5 Movement or Resale of Mold-Masters Products or Systems .....	1-2
1.6 Copyright .....	1-2
1.7 Units of Measure and Conversion Factors .....	1-2
 <b>Section 2 - Global Support .....</b>	 <b>2-1</b>
2.1 Worldwide Locations .....	2-1
 <b>Section 3 - Safety Information.....</b>	 <b>3-1</b>
3.1 Introduction.....	3-1
3.2 Safety Hazards of an Injection Molding Machine .....	3-1
3.3 Operational Hazards.....	3-5
3.4 Safety Symbols.....	3-7
3.5 Wiring Check .....	3-9
3.6 Lockout Safety.....	3-10
3.6.1 Electrical Lockout.....	3-11
3.6.2 Energy Forms and Lockout Guidelines.....	3-12
3.7 Disposal.....	3-13
3.8 Safety Hazards .....	3-14
3.9 Safety Guards.....	3-16
3.10 Dimensions and Weights.....	3-16
 <b>Section 4 - Components .....</b>	 <b>4-1</b>
4.1 Injection Unit Components .....	4-1
 <b>Section 5 - Installation .....</b>	 <b>5-1</b>
5.1 Crate Contents .....	5-1
5.2 Unpacking the Crate.....	5-2
5.3 Inspecting the injection unit .....	5-4
5.4 Lifting the injection unit .....	5-4
5.4.1 Before lifting the injection unit .....	5-4
5.4.2 Lift Connections .....	5-5
5.4.3 Lift Procedures.....	5-6
5.5 Installing the Injection Unit on a Mold.....	5-8
5.6 Installing the Controller .....	5-9
5.7 Operating Environment.....	5-10

<b>Section 6 - System Setup</b> .....	<b>6-1</b>
6.1 Connecting the Controller to the Injection Unit.....	6-1
6.1.1 Routing and Connecting the Servo Cables.....	6-1
6.1.2 Routing and Connecting the Heater, I/O, and Injection Molding Machine Cables.....	6-1
6.2 Connecting the Controller to a Robot.....	6-2
6.3 Connecting the Controller to an Injection Molding Machine.....	6-2
6.4 Pneumatic Connections.....	6-2
6.5 Cooling Connections.....	6-3
6.5.1 Cooling Water Schematic.....	6-4
6.5.2 Corrosion Caused by Condensation.....	6-5
6.5.3 Cooling Water Quality.....	6-5
<b>Section 7 - Controller Operation</b> .....	<b>7-1</b>
7.1 Introduction.....	7-1
7.2 Controller Startup and Shutdown.....	7-1
7.2.1 Controller Startup.....	7-2
7.2.2 Controller Shutdown.....	7-2
<b>Section 8 - Maintenance</b> .....	<b>8-1</b>
8.1 Preventive Maintenance Schedule.....	8-1
8.2 Torques.....	8-1
8.2.1 Screw Torques.....	8-1
8.2.2 Other Torques.....	8-2
8.3 Lubrication.....	8-3
8.3.1 Lubrication Guidelines.....	8-3
8.3.2 Lubricating the Injection Ball Screw.....	8-5
8.3.3 Lubricating the Linear Guides.....	8-7
8.4 Purging Plastic from the System.....	8-8
8.5 Purging Cooling Water from the System.....	8-9
8.6 Removing the Injection Unit for Maintenance.....	8-9
8.7 Replacing the Adapter Plate.....	8-10
8.7.1 Method 1: Manual Nozzle-Concentricity Adjustment.....	8-10
8.7.2 Method 2: Concentricity Adjustment Using an Alignment Tool.....	8-12
8.8 Replacing the Injection Nozzle.....	8-14
8.9 Calibrating the Linear Carriage Actuator.....	8-15
8.10 Referencing the Injection Axis.....	8-18
8.11 Removing the Hopper.....	8-19
8.12 Replacing the Vibe Tube Assembly.....	8-20
8.12.1 Removing the Feed Assembly.....	8-20
8.12.2 Installing the Vibe Tube Assembly.....	8-20
8.13 Cleaning and Replacing the Feed Screw.....	8-21
8.13.1 Preparing for Feed Screw Removal.....	8-21
8.13.2 Removing the Feed Screw.....	8-22
8.13.3 Cleaning the Feed Screw.....	8-24
8.13.4 Installing the Feed Screw.....	8-25
<b>Section 9 - Component Tests and System Alarms</b> .....	<b>9-1</b>
9.1 Thermocouple Electrical Test.....	9-1

9.2 Heater Continuity Test .....	9-1
9.3 Transducer Output Alarm.....	9-2
9.4 Control System Alarms .....	9-2
9.5 Servo-Motor Temperature Alarms.....	9-2
<b>Section 10 - Euromap 67.....</b>	<b>10-1</b>
10.1 Scope and Application .....	10-1
10.2 Description.....	10-1
10.3 Plugs and Socket Outlets .....	10-1
<b>Section 11 - Cooling Water .....</b>	<b>11-1</b>
11.1 Detailed Water-Quality Specifications.....	11-1
11.2 Cooling Line Contamination.....	11-2
<b>Index .....</b>	<b>I</b>

# Section 1 - Introduction

The purpose of this manual is to assist users in the integration, operation and maintenance of an E-Multi Mini. This manual is designed to cover most system configurations, but should be used in conjunction with E-Multi Mini Controller User Manual. If you need additional information specific to your system, or information in another language, please contact your representative or a Mold-Masters office.

## 1.1 Intended Use

Mold-Masters' E-Multi Mini systems have been built to process thermoplastic material at the required temperature for injection molding and must not be used for any other purpose. The E-Multi Mini is to be integrated with a host injection molding machine and not used as a standalone device. Any other uses would fall outside the engineered intent of this machine, which may be a safety hazard and will void any and all warranties.

## 1.2 Documentation

This manual is part of the documentation package for your order and should be referenced along with the following documents included in the package:

- The Bill of Materials (BOM). Together with the General Assembly drawing, the Bill of Materials should be referenced when ordering spare parts.
- General Assembly drawing
- Electrical drawings
- CE declaration of conformity and declaration of incorporation (EU only)

### 1.2.1 Document Release Details

Table 1-1 Document Release Details		
Document Number	Release Date	Version
UM--EMM--ENG--01	March 2026	1.0

### 1.2.2 Document Conventions

Some of the document and language conventions used in this document:

- The symbol ">>" at the end of a page shows that the text continues on the next page.
- The word "lubrication" is used for grease, and the term "lubrication fitting" is used for "grease nipple".

## 1.3 Warranty

For current warranty information please refer to the documents available on our website [www.moldmasters.com/support/warranty](http://www.moldmasters.com/support/warranty) or contact your Mold-Masters representative.

## 1.4 Returned Goods Policy

Please do not return any parts to Mold-Masters without pre-authorization and a return authorization number supplied by Mold-Masters.

Our policy is one of continuous improvement and we reserve the right to alter product specifications at any time without giving notice.

## 1.5 Movement or Resale of Mold-Masters Products or Systems

This documentation is intended for use in the country of destination for which the product or system was purchased. Mold-Masters takes no responsibility for documentation of products or systems if they are relocated or resold outside the intended country of destination, as stated on the accompanying invoice and/or waybill.

## 1.6 Copyright

© 2025 Mold-Masters (2007) Limited. All Rights Reserved. Mold-Masters® and the Mold-Masters logo are trademarks of Mold-Masters.

## 1.7 Units of Measure and Conversion Factors



### NOTE

The dimensions given in this manual are from original manufacturing drawings.

All values in this manual are in S.I. units or subdivisions of these units. Imperial units are given in parenthesis immediately after the S.I. units.

Table 1-2 Units of Measure and Conversion Factors		
Abbreviation	Unit	Conversion Value
bar	Bar	14.5 psi
in.	Inch	25.4 mm
kg	Kilogram	2.205 lb
kPa	Kilopascal	0.145 psi
gal	Gallon	3.785 l
lb	Pound	0.4536 kg
lbf	Pound force	4.448 N
lbf.in.	Pound force inch	0.113 Nm
l	Litre	0.264 gallon
min	Minute	
mm	Millimeter	0.03937 in.
mΩ	Milli Ohm	
N	Newton	0.2248 lbf
Nm	Newton Meter	8.851 lbf.in.
psi	Pound per square inch	0.069 bar
psi	Pound per square inch	6.895 kPa
rpm	Revolutions per minute	
s	Second	
°	Degree	
°C	Degree Celsius	0.556 (°F -32)
°F	Degree Fahrenheit	1.8 °C +32

# Section 2 - Global Support

## 2.1 Worldwide Locations

To find your nearest Mold-Masters office for sales or service support, please visit [www.moldmasters.com/location-map](http://www.moldmasters.com/location-map) or scan this QR code:



# Section 3 - Safety Information

## 3.1 Introduction

Please be aware that the safety information provided by Mold-Masters does not absolve the integrator and employer from understanding and following international and local standards for safety of machinery. It is the responsibility of the end integrator to integrate the final system, provide necessary e-stop connections, safety interlocks and guarding, to select the appropriate electrical cable for the region of use and to make sure compliance with all relevant standards.

It is the responsibility of the employer to:

- Properly train and instruct its personnel in the safe operation of equipment, including the use of all the safety devices.
- Provide its personnel with all necessary protective clothing, including such items as a face shield and heat resistant gloves.
- Make sure the original and continuing competence of personnel caring for, setting up, inspecting and maintaining injection molding equipment.
- Establish and follow a program of periodic and regular inspections of injection molding equipment to make sure it is in safe operating condition and proper adjustment.
- Make sure that no modifications, repairs, or rebuild of portions are made to the equipment that reduces the level of safety existing at time of manufacture or remanufacture.

## 3.2 Safety Hazards of an Injection Molding Machine

The following safety hazards are most commonly associated with plastic injection molding equipment (see European Standard EN201 or American Standard ANSI/SPI B151.1).



### NOTE

Refer to all machine manuals and local regulations and codes for further safety information.

Refer to Figure 3-1 Hazard areas of an injection molding machine (front view) when reading Table 3-1 Safety Hazards on page 3-2.

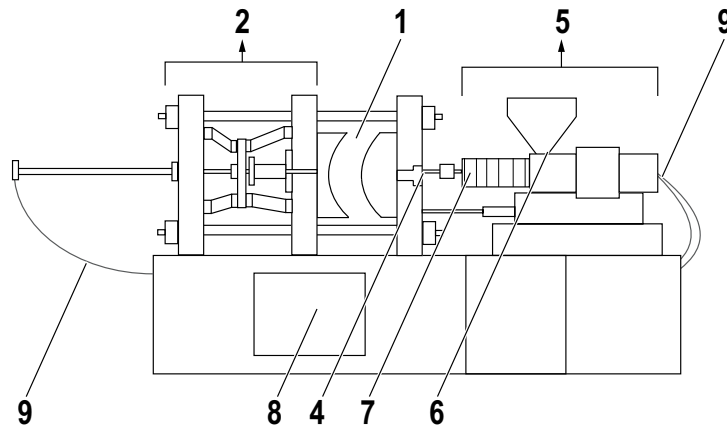

Figure 3-1 Hazard areas of an injection molding machine (front view)

>>

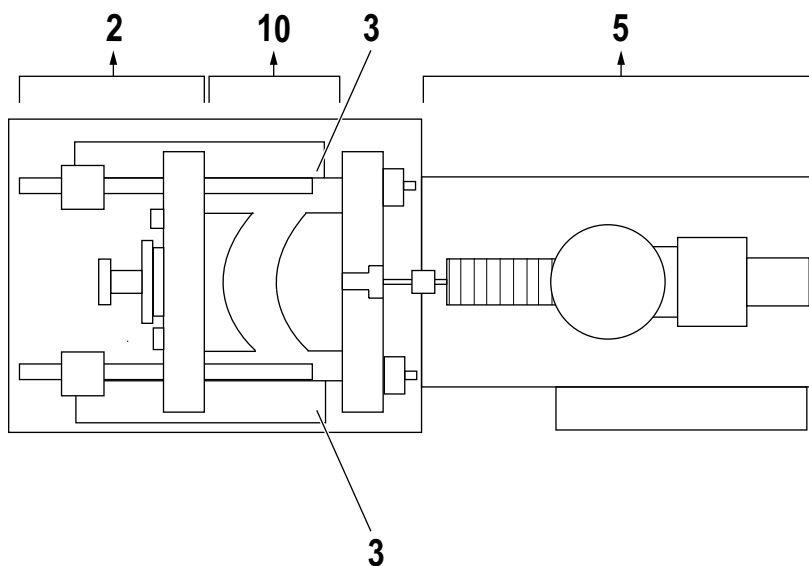

Figure 3-2 Hazard areas of an injection molding machine (top view)

Table 3-1 Safety Hazards		
Position	Hazard Area	Potential Hazards
1	<b>Mold Area</b> Area between the platens.	<b>Mechanical Hazards</b> Crushing and/or shearing and/or impact hazards caused by: <ul style="list-style-type: none"> <li>• Movement of the platen.</li> <li>• Movements of the injection barrel(s) into the mold area.</li> <li>• Movements of cores and ejectors and their drive mechanisms.</li> <li>• Tie bar motion.</li> </ul> <b>Thermal Hazards</b> Burns and/or scalds due to operating temperature of: <ul style="list-style-type: none"> <li>• The mold heating elements.</li> <li>• Plasticized material released from / through the mold.</li> </ul>
2	Clamping Mechanism Area	<b>Mechanical Hazards</b> Crushing and/or shearing and/or impact hazards caused by: <ul style="list-style-type: none"> <li>• Movement of the platen.</li> <li>• Movement of the drive mechanism of the platen.</li> <li>• Movement of the core and ejector drive mechanism.</li> </ul>
3	Movement of Drive Mechanisms Outside the Mold Area and Outside the Clamping Mechanism Area.	<b>Mechanical Hazards</b> Mechanical hazards of crushing, shearing and/or impact caused by the movements of: <ul style="list-style-type: none"> <li>• Core and ejector drive mechanism.</li> </ul>

>>

Position	Hazard Area	Potential Hazards
4	<p><b>Nozzle Area</b> The nozzle area is the area between the barrel and the sprue bushing.</p>	<p><b>Mechanical Hazards</b> Crushing, shearing hazards, and/or impact hazards caused by:</p> <ul style="list-style-type: none"> <li>• Forward movement of the plasticizing and/or injection unit including nozzle.</li> <li>• Movements of parts of the power operated nozzle shutoff and their drives.</li> <li>• Over pressurization in the nozzle.</li> </ul> <p><b>Thermal Hazards</b> Burns and/or scalds due to operating temperature of:</p> <ul style="list-style-type: none"> <li>• The nozzle.</li> <li>• Material discharging from the nozzle.</li> </ul>
5	<p>Plasticizing and/or Injection Unit Area Area from the adapter / barrel head / end cap to the extruder motor above the sled including the carriage cylinders.</p>	<p><b>Mechanical Hazards</b> Crushing, shearing and/or drawn-into hazards caused by:</p> <ul style="list-style-type: none"> <li>• Unintentional gravity movements e.g. for machines with plasticizing and/or injection unit positioned above the mold area.</li> <li>• The movements of the screw and/or the injection plunger in the cylinder accessible through the feed opening.</li> <li>• Movement of the carriage unit.</li> </ul> <p><b>Thermal Hazards</b> Burns and/or scalds due to operating temperature of:</p> <ul style="list-style-type: none"> <li>• The plasticizing and/or injection unit.</li> <li>• The heating elements e.g. heater bands.</li> <li>• The material and/or vapors discharging from the vent opening, feed throat or hopper.</li> </ul> <p><b>Mechanical and/or Thermal Hazard</b></p> <ul style="list-style-type: none"> <li>• Hazards due to reduction in mechanical strength of the plasticizing and/or injection cylinder due to overheating.</li> </ul>
6	<p>Feed Opening</p>	<p>Pinching and crushing between injection screw movement and housing.</p>
7	<p>Area of the Heater Bands of the Plasticizing and/or Injection Cylinders</p>	<p>Burns and/or scalds due to operating temperature of:</p> <ul style="list-style-type: none"> <li>• The plasticizing and/or injection unit.</li> <li>• The heating elements e.g. heater bands.</li> <li>• The material and/or vapors discharging from the vent opening, feed throat or hopper.</li> </ul>

>>

Position	Hazard Area	Potential Hazards
8	Parts Discharge Area	<p><b>Mechanical Hazards</b>            Accessible Through the Discharge Area Crushing, shearing and/or impact hazards caused by:</p> <ul style="list-style-type: none"> <li>• Closing movement of the platen.</li> <li>• Movements of cores and ejectors and their drive mechanisms.</li> </ul> <p><b>Thermal Hazards</b>            Accessible through the discharge area Burns and or scalds due to operating temperature of:</p> <ul style="list-style-type: none"> <li>• The mold.</li> <li>• Heating elements of the mold.</li> <li>• Material released from / trough the mold.</li> </ul>
9	Hoses	<p>Whipping action caused by hose assembly failure.</p> <ul style="list-style-type: none"> <li>• Possible release of fluid under pressure that can cause injury.</li> <li>• Thermal hazards associated with hot fluid.</li> </ul>
10	Area Inside the Guards and Outside the Mold Area	<p>Crushing and/or shearing and/or impact hazards caused by:</p> <p>Movement of the platen.</p> <ul style="list-style-type: none"> <li>• Movement of the drive mechanism of the platen.</li> <li>• Movement of the core and ejector drive mechanism.</li> <li>• Clamp opening movement.</li> </ul>
-	Electrical Hazards	<ul style="list-style-type: none"> <li>• Electrical or electromagnetic disturbance generated by the motor control unit.</li> <li>• Electrical or electromagnetic disturbance that can cause failures in the machine control systems and adjacent machine controls.</li> <li>• Electrical or electromagnetic disturbance generated by the motor control unit.</li> </ul>
-	Hydraulic Accumulators	High pressure discharge.
-	Power Operated Gate	Crush or impact hazards caused by the movement of the power operated gate.
-	Vapors and Gases	Certain processing conditions and/or resins can cause hazardous fumes or vapors.

### 3.3 Operational Hazards









#### **WARNING**

- Refer to all machine manuals and local regulations and codes for safety information.
- The equipment supplied is subjected to high injection pressures and high temperatures. Make sure that extreme caution is observed in the operation and maintenance of the injection molding machines.
- Only fully trained personnel should operate or maintain equipment.
- Do not operate the equipment with unconfined long hair, loose clothing or jewelry, including name badges, neckties, etc. These may get caught in the equipment and can cause death or serious injury.
- Never disable or bypass a safety device.
- A burn hazard exists from material during routine purging. Wear heat-resistant personal protective equipment (PPE) to prevent burns from contact with hot surfaces or splatter of hot material and gases.
- All operators should wear personal protective equipment, such as face shields and use heat resistant gloves when working around the feed inlet, purging the machine or cleaning the gates of the mold.
- Remove purged material from the machine immediately.
- Decomposing or burning material could result in noxious gases being emitted from the purged material, feed inlet or mold.
- Make sure proper ventilation and exhaust systems are in place to help prevent inhalation of harmful gases and vapors.
- Consult manufacturer's Material Safety Data Sheets (MSDS).
- Water and/or hydraulics on the mold may be in close proximity to electrical connections and equipment. Water leakage may cause an electrical short circuit. Hydraulic fluid leakage may cause a fire hazard. Always keep water and/or hydraulic hoses and fittings in good condition to avoid leaks.
- Never perform any work on the mold machine unless the hydraulic pump has been stopped.
- Check frequently for possible oil/water leaks. Stop the machine and make repairs.













>>

- Make sure that the cables are connected to the correct motors. Cables and motors are clearly labeled. Reversing the cables can result in unexpected and uncontrolled motion causing a safety risk or damage to the machine.
- A crushing hazard exists between the nozzle and mold melt inlet during carriage forward motion.
- A possible shearing hazard exists between the edge of the injection guard and the injection housing during injection.
- The open feed port could present a hazard to a finger or a hand inserted during operation of the machine.
- The electric servo motors could overheat presenting a hot surface which could cause burns to someone touching it.
- The barrel, barrel head, nozzle, heater bands and mold components are hot surfaces which could result in burns.
- Keep flammable liquids or dust away from the hot surfaces as they could ignite.
- Follow good housekeeping procedures and keep floors clean to prevent slips, trips and falls due to spilled material on the work floor.
- When doing any work on the machine that requires moving and lifting the machine, make sure that lifting equipment (eyebolts, fork lift truck, cranes, and others) have sufficient capacity to handle the weight of the mold, auxiliary injection unit, or Hot Runner.
- Connect all lifting devices and support the machine using a crane of adequate capacity before commencing work. Failure to support the machine can result in severe injury or death.

### 3.4 Safety Symbols

Table 3-2 Safety Symbols	
Symbol	General Description
	<p><b>General – Warning</b></p> <p>Indicates an immediate or potentially hazardous situation, which if not avoided, could result in a serious injury or death, and/or damage to equipment.</p>
	<p><b>Warning – Barrel Cover Grounding Strap</b></p> <p>Lockout/tagout procedures must be followed before removing the barrel cover. Barrel cover can become energized upon removal of grounding straps and contact can result in death or serious injury. Grounding straps must be reconnected before reconnecting power to machine.</p>
	<p><b>Warning – Crushing and/or Impact Points</b></p> <p>Contact with moving parts can cause serious crushing injury. Always keep guards in place.</p>
	<p><b>Warning – Crush Hazard Closing Mold</b></p> <p>Moving mold on injection molding machine can crush, dismember, snag, hit and entrap causing serious injury or death.</p>
	<p><b>Warning – Hazardous Voltage</b></p> <p>Contact with hazardous voltages will cause death or serious injury. Turn off power and review the electrical schematics before servicing equipment. May contain more than one live circuit. Test all circuits before handling to make sure circuits have been de-energized.</p>
	<p><b>Warning – High Pressure</b></p> <p>Overheated fluids may cause severe burns. Discharge pressure before disconnecting water lines.</p>
	<p><b>Warning – Hot Surfaces</b></p> <p>Contact with exposed hot surfaces will cause serious burn injury. Wear protective gloves when working near these areas.</p>

>>

Symbol	General Description
	<p><b>Mandatory – Lockout/tagout</b></p> <p>Make sure that all energies are properly locked out, and remain locked out until the service work is completed. Servicing equipment without disabling all internal and external power sources can cause death or serious injury. De-energize all internal and external power sources (electrical, hydraulic, pneumatic, kinetic, potential, and thermal).</p>
	<p><b>Warning – Read Manual Before Operation</b></p> <p>Personnel should read and understand all instructions in the manuals before working on equipment. Only properly trained personnel should operate the equipment.</p>
	<p><b>Warning – Slip, Trip or Fall Hazard</b></p> <p>Do not climb on equipment surfaces. Serious slip, trip or fall injuries can result from personnel climbing on equipment surfaces.</p>
	<p><b>Caution</b></p> <p>Failure to follow instructions may damage equipment.</p>
	<p><b>Important</b></p> <p>Indicates additional information or used as a reminder.</p>
	<p><b>Warning – Body Crush Hazard</b></p> <p>End of motor moves back during hold or recovery. Hazard may exist between the end of the injection unit motor assembly and a nearby solid obstacle.</p>
	<p><b>Warning – Tip Over Hazard</b></p> <p>Injection unit could tip over when installed on stand or if stored vertically on the floor or a table without adequate support.</p>
	<p><b>Warning – Electric Shock Hazard</b></p> <p>Contact with hazardous voltages will cause death or serious injury. Turn off power and review electrical schematics before servicing equipment. May contain more than one live circuit. Test all circuits before handling to make sure circuits have been de-energized.</p>
	<p><b>Warning – Hot Surface Hazard</b></p> <p>Contact with exposed hot surfaces will cause serious burn injury. Wear adequate personal protective equipment (PPE) when working near these areas.</p>
	<p><b>Warning – Entanglement Hazard (Belt Drive)</b></p> <p>A person could become entangled in the drive belt of the injection unit. Always keep guards in place.</p>
	<p><b>Warning - Pinch Point Hazard</b></p> <p>A pinch point exists in this area which could result in a pinching, crushing or shearing injury to a person.</p>
	<p><b>Warning – Splash Hazard</b></p> <p>Molten material or high pressure gas can cause death or severe burns. Wear personal protective equipment (PPE) while servicing the feed throat, nozzle, mold areas, and when purging the injection unit.</p>
	<p><b>Mandatory Lift Points</b></p> <p>Mandatory lift points must be used. If wrong lift points are used the unit could become unstable when being moved.</p>

### 3.5 Wiring Check

**CAUTION**

Failure to do wiring or connections properly will result in equipment failure.

**System-Mains Supply Wiring:**

1. Before connecting the system to a power supply, it is important to check that the wiring between the system and the power supply has been done correctly. Refer to the electrical schematic.
2. Particular attention must be given to the current rating of the power supply. For example, if a controller is rated at 63 A, then the power supply must also be rated at 63 A.
3. Check that the phases of power supply are wired correctly.

**Communications Interface and Control Sequence:**

4. It is the customer's responsibility to verify functionality of any custom machine interface at safe speeds, prior to operating equipment in the production environment at full speed in automatic mode.
5. It is the customer's responsibility to verify all required motion sequences are correct, prior to operating equipment in the production environment at full speed in automatic mode.
6. Switching the machinery into Auto mode without having verified the control interlocks and motion sequence are correct, may cause damage to machinery and/or equipment.

### 3.6 Lockout Safety



#### **WARNING - MANDATORY LOCKOUT/TAGOUT**

Use lockout/tagout to prevent machine operation during maintenance.

All maintenance should be performed by properly trained personnel based on local laws and regulation. Electrical products may not be grounded when removed from the assembled or normal operating condition.

Often power sources are inadvertently turned on or valves are opened mistakenly before maintenance work is completed, resulting in serious injuries and fatalities. Therefore, it is important to make sure that all energies are properly locked out and that they remain locked out until the work is completed.

If a lockout is not performed, uncontrolled energies could cause:

- Electrocution from contact with live circuits.
- Cuts, bruises, crushing, amputations or death, resulting from entanglement with belts, chains, conveyors, rollers, shafts, impellers.
- Burns from contact with hot parts, materials or equipment such as furnaces.
- Fires and explosions.
- Chemical exposures from gases or liquids released from pipelines

1. Shut down machine using normal operational shutdown procedure and controls. This should be done by, or in consultation with the machine operator.
2. After ensuring that the machinery has been completely shut down, and all controls in the “off” position, open the main disconnect switch located in the field.
3. Using your own personal padlock, or one assigned by your supervisor, lock the disconnect switch in the off position. Do not lock only the box. Remove the key and retain. Complete a lockout tag and affix to the disconnect switch. Each person working on the equipment must follow this step. The lock of the person doing the work or in charge must be installed first, remain throughout and be removed last. Test the main disconnect switch and make sure it cannot be moved to the “on” position.
4. Try to start the machine using the normal operation controls and point of operation switches to make sure that the power has been disconnected.
5. Other sources of energy that could create a hazard while working on the equipment must also be de-energized and appropriately “locked-out”. This can include gravity, compressed air, hydraulics, steam and other pressurized or hazardous liquids and gases (see table below).
6. When the work is completed, prior to removing the last lock, make sure the operational controls are in the “off” position so that the main disconnect switching is done under “no load”. Make sure all blocks, tools and other foreign materials are removed from machine. Also Make sure that all personnel that may be affected are informed that the lock(s) will be removed.
7. Remove lock and tag, and close the main disconnect switch if permission has been given.
8. When the work has not been completed on the first shift, the next operator should install a personal lock and tag before the first operator removes the original lock and tag. If the next operator is delayed, a lock and tag could be installed by the next supervisor. Lockout procedures should indicate how the transfer is to be conducted.

>>

9. It is important that, for their personal protection, each worker and/or fore person working in or on a machine places his/her own safety lock on the disconnect switch. Use tags to spotlight work in progress and give details of work being done. Only when the work is completed and the work permit signed off, may each worker remove his/her lock. The last lock to be removed should be that of the person supervising the lockout and this responsibility should not be delegated.

© Industrial Accident Prevention Association, 2008.

### **3.6.1 Electrical Lockout**

Employers must provide an effective lockout/tagout program.



#### **WARNING - ELECTRIC SHOCK HAZARD**

Do not enter the cabinet without first isolating the power supplies.

There may be more than one power source feeding the equipment so you must make sure that all sources are effectively locked out. Voltage and amperage cables are connected to the controller and the mold. Electric power must be shut off and lockout/tagout procedures followed prior to installing or removing any cables. Make sure proper grounding of all electrical components before performing any maintenance to avoid potential risk of electrical shock.

### 3.6.2 Energy Forms and Lockout Guidelines

Table 3-3 Energy Forms, Energy Sources and General Lockout Guidelines		
Energy Form	Energy Source	Lockout Guidelines
Electrical Energy	<ul style="list-style-type: none"> <li>• Power transmission lines</li> <li>• Machine power cords</li> <li>• Motors</li> <li>• Solenoids</li> <li>• Capacitors (stored electrical energy)</li> </ul>	<ul style="list-style-type: none"> <li>• Turn off power at machine first (i.e., at point of operation switch), and then at the main disconnect switch for the machine.</li> <li>• Lock and tag the main disconnect switch.</li> <li>• Fully discharge all capacitive systems (e.g., cycle machine to drain power from capacitors) according to the manufacturer's instructions.</li> </ul>
Hydraulic Energy	<ul style="list-style-type: none"> <li>• Hydraulic systems (e.g., hydraulic presses, rams, cylinders, hammers)</li> </ul>	<ul style="list-style-type: none"> <li>• Shut off, lock (with chains, built-in lockout devices, or lockout attachments) and tag valves.</li> <li>• Bleed off and blank lines as necessary.</li> </ul>
Pneumatic Energy	<ul style="list-style-type: none"> <li>• Pneumatic systems (e.g., lines, pressure reservoirs, accumulators, air surge tanks, rams, cylinders)</li> </ul>	<ul style="list-style-type: none"> <li>• Shut off, lock (with chains, built-in lockout devices, or lockout attachments) and tag valves.</li> <li>• Bleed off excess air.</li> <li>• If pressure cannot be relieved, block any possible movement of machinery.</li> </ul>
Kinetic Energy (Energy of a moving object or materials. Moving object may be powered or coasting)	<ul style="list-style-type: none"> <li>• Blades</li> <li>• Flywheels</li> <li>• Materials in supply lines</li> </ul>	<ul style="list-style-type: none"> <li>• Stop and block machine parts (e.g. stop flywheels and Make sure that they do not recycle).</li> <li>• Review entire cycle of mechanical motion, Make sure that all motions are stopped.</li> <li>• Block material from moving into area of work.</li> <li>• Blank as necessary.</li> </ul>
Potential Energy (Stored energy that an object has the potential to release due to its position)	<ul style="list-style-type: none"> <li>• Springs (e.g., in air brake cylinders)</li> <li>• Actuators</li> <li>• Counterweights</li> <li>• Raised loads or movable part of a press or lifting device</li> </ul>	<ul style="list-style-type: none"> <li>• If possible, lower all suspended parts and loads to the lowest (rest) position.</li> <li>• Block parts that might be moved by gravity.</li> <li>• Release or block spring energy.</li> </ul>
Thermal Energy	<ul style="list-style-type: none"> <li>• Supply lines</li> <li>• Storage tanks and vessels</li> </ul>	<ul style="list-style-type: none"> <li>• Shut off, lock (with chains, built-in lockout devices, or lockout attachments) and tag valves</li> <li>• Bleed off excess liquids or gases</li> <li>• Blank lines as necessary.</li> </ul>

### **3.7 Disposal**

Mold-Masters declines any responsibility for personal injury or personal damage arising from reuse of the individual components, if these parts are used other than for the original and proper intended purpose.

Recycling of the materials occupies a forefront position during the disposal process.

1. The injection unit must be disconnected from the power supply fully and properly before disposal, including electricity, pneumatics, and cooling.
2. Make sure that the system to be disposed of is free from fluids. The electrical components are to be dismantled, separating them accordingly as environmentally friendly waste or disposed as hazardous waste if necessary.
3. Remove the wiring. The electronic components are to be disposed in accordance with the national electric scrap ordinance.
4. The metal parts are to be returned for metal recycling (waste metal and scrap trade). The instructions of the corresponding waste disposal company are to be observed in this case.

### 3.8 Safety Hazards

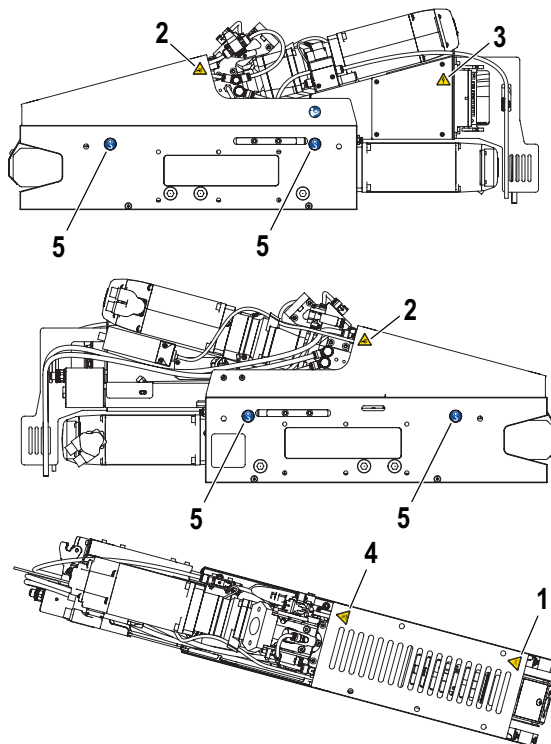

Figure 3-4 Injection unit safety hazards

Table 3-4 Injection Unit Safety Hazards		
S.No	Hazard Type	Potential Hazards
<b>Mechanical Hazards</b>		
1	Molten Material Splashing Hazard	High pressure molten plastic may spray from the nozzle. Always use personal protective equipment (PPE). High temperature molten plastic may spray from a blocked feed port. Always use personal protective equipment (PPE).
2	Pinching Hazard	A possible pinching hazard exists between the top cover and the extruder assembly during carriage stroke.
<b>Electrical Hazard</b>		
3	Contact of Persons with High Voltage	Heaters, servo motors and electrical components in the controller could come in contact with a person. Do not remove covers when energized.
<b>Thermal Hazards</b>		
4	Possible Contact of Persons with High Temperature Material.	The extruder barrel could result in burns. Melted plastic during routine purging could cause burns. Hot plastic or gasses could be released from the feed port when clearing a blockage. The electric servo motors could overheat presenting a hot surface which could cause burns to someone touching it.
<b>Ergonomic Hazards</b>		
5	Lift Hazard	Attempting to lift or support the unit during installation could result in injury.



### 3.9 Safety Guards



**WARNING**

Do not operate the machine with the guards removed. Guards should not be removed unless maintenance is required, and should be replaced after maintenance is complete.



**CAUTION**

When installing the machine guard (top cover) and the barrel covers, make sure that they do not pinch the water lines, air lines, and thermocouples.

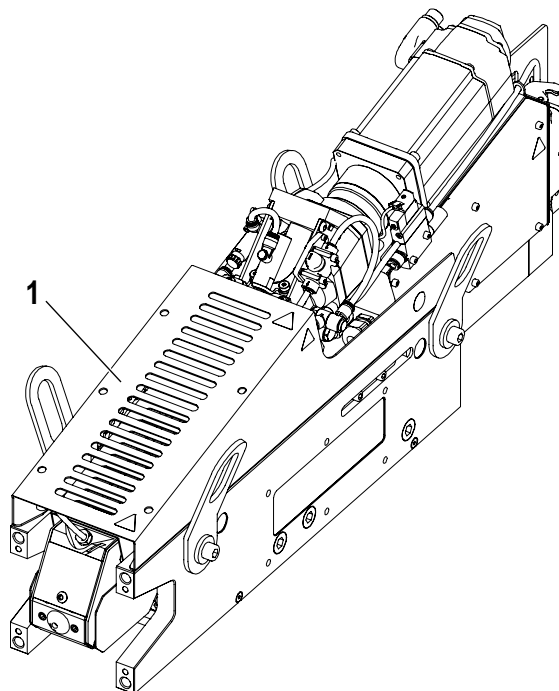

Figure 3-5 Layout of top cover guard

Table 3-5 Guards	
Position	Part
1	Top cover

### 3.10 Dimensions and Weights

Dimensions and weights shown in the following are for packed wooden crates containing standard units. Additional options may add weight or require additional crates. Specifications are subject to change without notice.

Table 3-6 Shipping Dimensions and Weights				
	Length mm (in.)	Width mm (in.)	Height mm (in.)	Weight kg (lb)
Injection unit	1,000 (39)	140 (6)	335 (13)	63 (138)
Controller	635 (25)	330 (13)	930 (36)	
Crate	1,210 (48)	410 (16)	620 (25)	20 (0.8)

# Section 4 - Components

## 4.1 Injection Unit Components

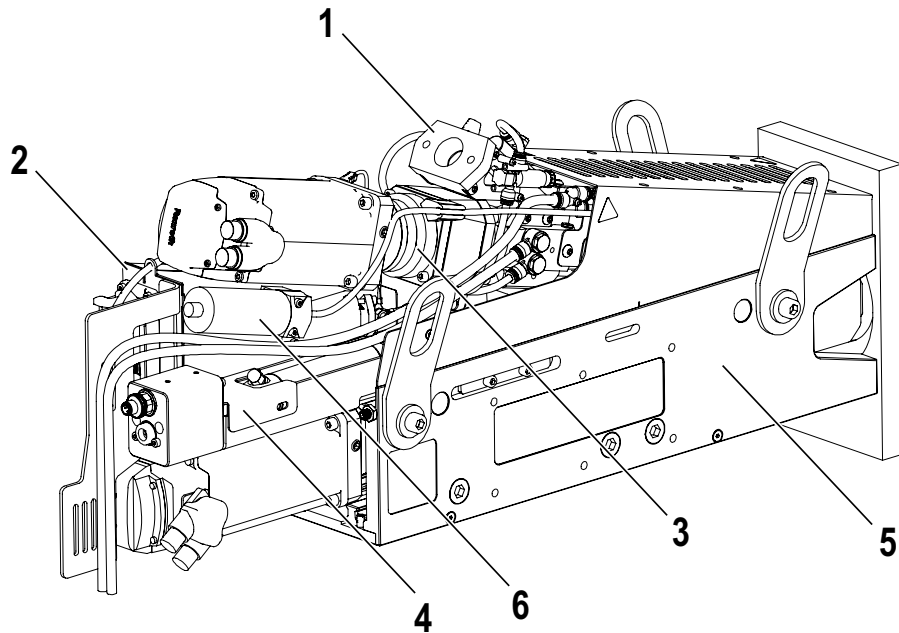

Figure 4-1 Injection unit components (back)

Table 4-1 Injection Unit Components (back)		
Position	Part	Description
1	Feeder tube	Used to attach a hopper or other feeding device to the Injection unit and to feed plastic pellets into the barrel
2	Electrical box	Used to protect electrical components and wiring connections
3	Gearbox	Used to transmit power and adjust torque between rotating shafts
4	Linear actuator	Used to engage the nozzle tip with the manifold inlet
5	Chassis assembly	A rigid frame that connects the moving components to the adapter plate and mold
6	Melt pressure transducer	Used to provide melt pressure feedback to the controller

>>

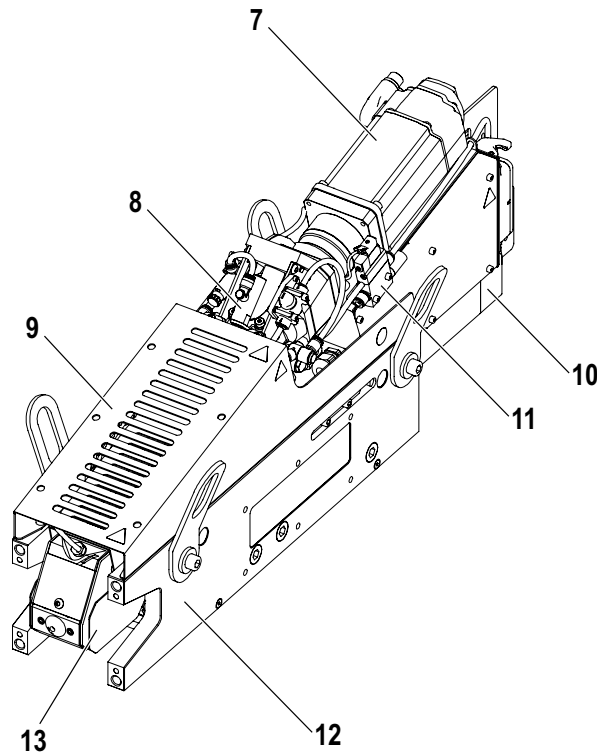

Figure 4-2 Injection unit components (front)

Table 4-2 Injection Unit Components (front)		
Position	Part	Description
7	Servo motor – Extruder assembly	Provides power for the feed screw
8	Linear vibrator	Used to help plastic pellets feed properly into the feed block
9	Top cover	Used as a protective shield for the internal components
10	Servo motor – Injection assembly	Provides power to the injection housing
11	Solenoid valve	Used to control the flow of air to the vibrator (7)
12	Side plate	Part of the chassis assembly
13	Manifold assembly	Receives the melted plastic from the extruder and contains the shooting pot and plunger which injects the melted plastic into the mold.

## Section 5 - Installation



### NOTE

Make sure you have fully read Section 3 - Safety Information on page 3-1 before unpacking, cleaning, or assembling the E-Multi Mini.

Integrator: It is your responsibility to understand and follow international and local standards for safety of machinery when integrating the E-Multi Mini into the molding system. This includes providing necessary emergency stop connections, safety interlocks and guarding to protect operators.



### WARNING - TIP OVER HAZARD

The injection unit presents a tip/crush hazard when stored vertically on the floor or a table. The unit presents a tip/crush hazard when being moved from a vertical to horizontal position during installation.



### WARNING - LOCKOUT

Make sure that all energies are properly locked out in the controller and molding machine before installation of the injection unit into the system.



### CAUTION

The injection unit is designed to be used only with molds capable of accepting auxiliary injection units.

Make sure the injection unit placement will not interfere with injection molding machine movement. Check that all coolant, hydraulic and air lines as well as electrical cables will not interfere with the moving parts of the mold, machine or robot. The lines must be of sufficient length so that they will not strain or pinch when the mold halves separate.



### WARNING - BODY CRUSH HAZARD

When doing any work that requires lifting the machine, connect all lifting devices and support the machine using a crane of adequate capacity before commencing work. Failure to support the machine can result in severe injury or death. See Section 3.10 Dimensions and Weights on page 3-16 for weight, dimensions and safe lifting instructions.

### 5.1 Crate Contents

#### Injection Unit Crate:

- injection unit
- Lifting hardware
- Horizontal and vertical feed blocks, feed tube and feed adapter and hardware
- Adapter plate and hardware (optional)

>>

**Controller Crate:**

- Controller
- Two servo power and feedback cable sets
- Heat, I/O and E67 cables
- SPI adapters (optional)
- Diagnostic kit (optional)
- Documentation package
- Lubrication kit

**5.2 Unpacking the Crate**



**CAUTION**

Make sure you have a clean, flat surface to work on. Clear any obstacles to have enough space for unpacking the unit.

1. Remove the lid from the crate.
2. Visually inspect the injection unit for any signs of damage during shipping.
3. Remove the lag screws that secure the wooden supports from the crate.

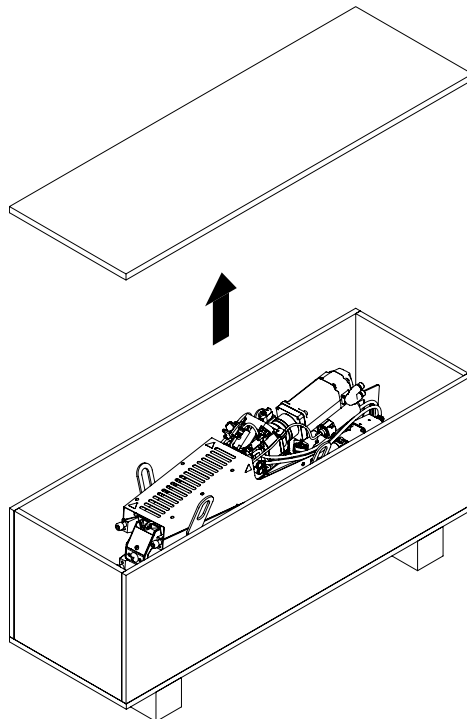

*Figure 5-1 Opening the crate*

>>

4. Connect slings with shackles or chain hooks to the lifting plates on the E-multi Mini and a crane or hoist to lift the unit out of the crate. Make sure the slings are secure and have enough support. Make sure to lift the injection unit straight up to avoid any unnecessary strain or damage. See the following drawing.

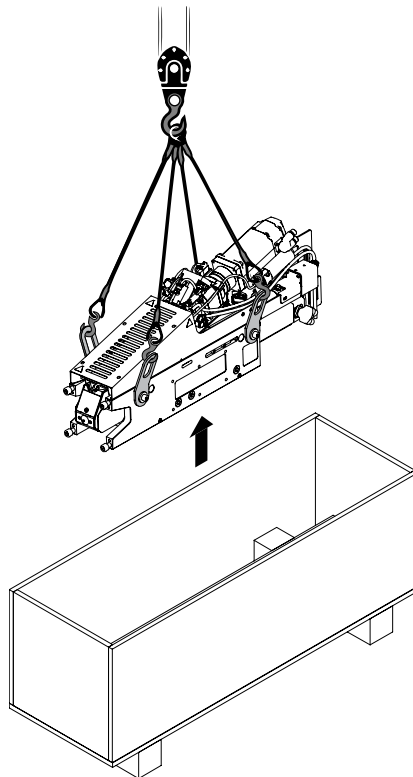

*Figure 5-2 Lifting the E-multi Mini out of the crate*

5. Remove the plastic bag that is wrapped around the injection unit. Be careful to avoid damaging any components.
6. Do a final inspection of the injection unit to make sure it is in good condition and ready for setup. If there is any damage, please contact your Mold-Masters representative.
7. Properly dispose of or recycle the plastic bag, and crate materials as per your local regulations.

### 5.3 Inspecting the injection unit

1. Check that the injection unit was not damaged during shipping.
2. Check all wires and cables. Make sure they are not kinked or damaged and are connected properly.

### 5.4 Lifting the injection unit



#### **WARNING - BODY CRUSH HAZARD**

When doing any work on the machine that requires lifting the machine, connect all lifting devices and support the machine using a crane of adequate capacity before commencing work. Failure to support the machine can result in severe injury or death.

Never use the motor as a lifting point.

Never use an injection unit attached to the mold as a lifting point.

#### 5.4.1 Before lifting the injection unit

1. Choose lift equipment that is rated for the prescribed load. See the equipment tag.
2. Define the load path: the path and orientation that the item will move in while it is being lifted, and the location and orientation where it will be set down.
3. Use recommended attachment points only. See Section 5.4.2 Lift Connections on page 5-5.
4. Identify and avoid potential pinch points: where an individual or a component of the lifting equipment or load may be caught between two surfaces.
5. Secure and balance the load in the chain or lifting device before it is lifted more than a few inches.
6. Minimize swinging by bringing the hook over the load appropriately.
7. Move powered hoists slowly into engagements with loads.

### 5.4.2 Lift Connections



**WARNING**

Before you lift the injection unit, make sure to position the injection unit horizontally on a flat surface. Refer to Section 5.2 Unpacking the Crate on page 5-2.



**NOTE**

Read Section 3.10 Dimensions and Weights on page 3-16 before doing any lifting procedure.

#### 5.4.2.1 Vertical Lift Connections

Rotate the top lifting plates 90 degree clockwise to lift the injection unit vertically as shown in Figure 5-3 Vertical lift connections.

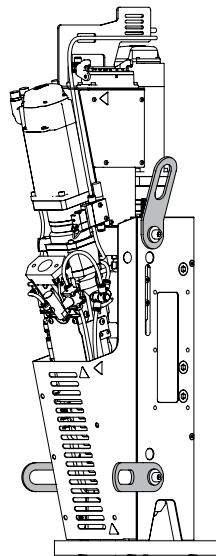

Figure 5-3 Vertical lift connections

#### 5.4.2.2 Horizontal Lift Connections

Make sure that all lifting plates are in upright position to lift the injection unit horizontally. See Figure 5-4 Horizontal lift connections.

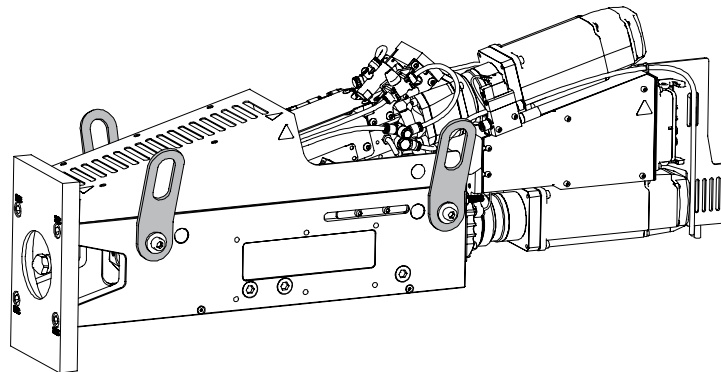

Figure 5-4 Horizontal lift connections

### 5.4.3 Lift Procedures



#### NOTE

Read Section 3.10 Dimensions and Weights on page 3-16 before doing any lifting procedure.

#### 5.4.3.1 Vertical Lift Procedure

1. Make sure that all lifting plates are properly connected with two long slings at the common shackle points.
2. Lift the injection unit in a controlled manner. Make sure it is stable and avoid any swinging or tilting.

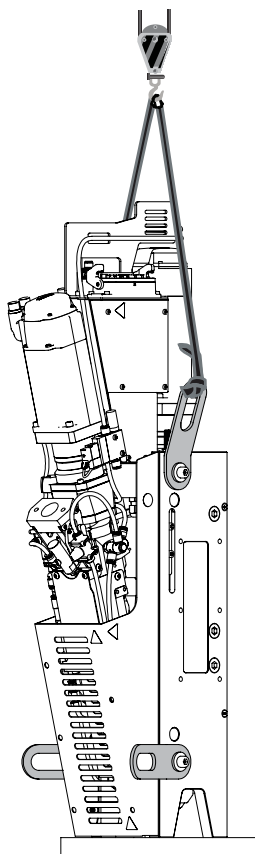
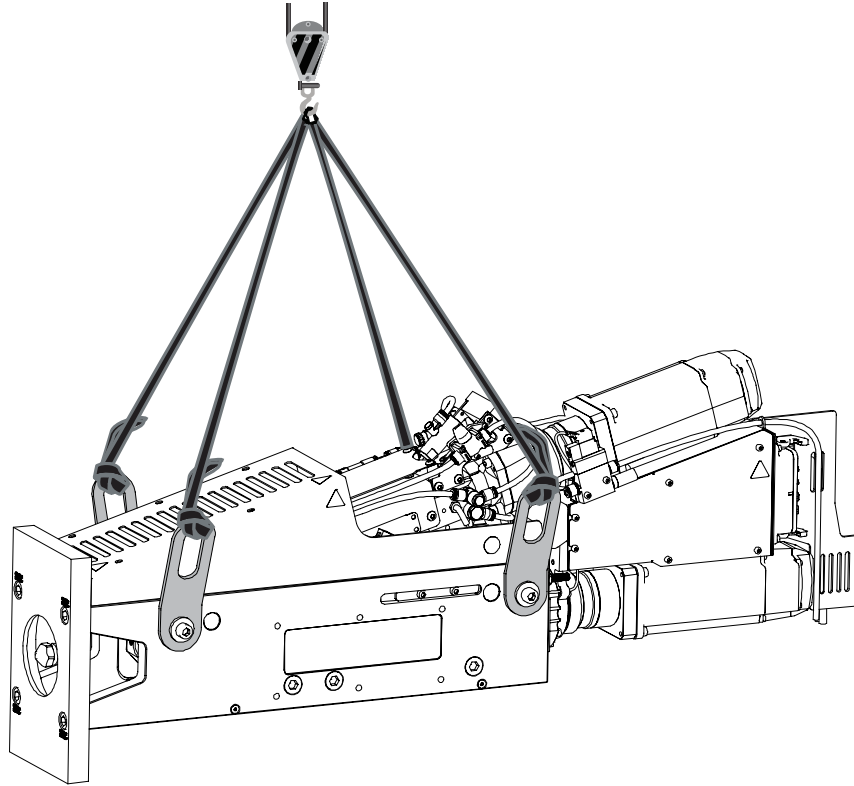

Figure 5-5 Vertical lifting

3. Install the injection unit on the mold. See Section 5.5 Installing the Injection Unit on a Mold on page 5-8.

### 5.4.3.2 Horizontal Lift Procedure

1. Make sure that all lifting plates are properly connected with four long slings at the common lifting points. See Figure 5-6 Horizontal lifting.
2. Lift the injection unit in a controlled manner. Make sure it is stable and avoid any swinging or tilting.



*Figure 5-6 Horizontal lifting*

3. Install the injection unit on the mold. See Section 5.5 Installing the Injection Unit on a Mold.

## 5.5 Installing the Injection Unit on a Mold



### WARNING - CRUSH HAZARD

The end of the injection motor moves back 100 mm (4 in.) max. stroke during carriage motion. A hazard may exist between the end of the injection unit motor assembly and a nearby solid obstacle.

Integrator: Install suitable safety guarding to mitigate the crush hazard.



### WARNING - CUT HAZARD

For horizontally-oriented machines with a high centerline height, the end of the machine could hit your head, which is a cut hazard.

Integrator: Install suitable guarding and warnings.



### WARNING

The screws securing the adapter plate to the injection unit and the adapter plate to the Injection molding machine must be tightened to the correct torque. See Table 8-2 Screw Torques on page 8-1.



### CAUTION

Make sure that the carriage is retracted and the nozzle does not touch the inlet when the injection unit is mounted to the mold. Otherwise serious damage may be caused to the injection unit or inlet and this damage is not covered under warranty.



### NOTE

Refer to the installation drawing supplied with the unit for complete information on services and connections.

1. Clean the injection molding machine and mold where the injection unit will be mounted. Any plastic residue on the manifold inlet must be removed to ensure proper nozzle contact.
2. Install the adapter plate onto the injection unit. See Section 8.7 Replacing the Adapter Plate on page 8-10.
3. Clean the adapter-plate mating surfaces.

The following step begins with the injection unit attached to lifting equipment.



### WARNING - CRUSH HAZARD

There is a crush hazard between the adapter plate and the mounting surface.

4. Install the injection unit horizontally or vertically as described in the following.
  - a) For vertical installations, lift the injection unit into place above the manifold inlet and install the screws. Tighten in a crisscross pattern to the specified torque.
  - b) For horizontal installations, move the injection unit into place beside the manifold inlet. Verify that the stand is at the correct height and install the screws. Tighten in a cross pattern to the specified torque.
5. Remove the lifting equipment from the injection unit.

## 5.6 Installing the Controller



### NOTE

Make sure that you have fully read Section 3 - Safety Information on page 3-1 before connecting or operating the controller.

Integrator: It is your responsibility to understand and follow international and local standards for safety of machinery when integrating the controller with the molding system.



### WARNING - TRIP HAZARD

Integrator: Make sure that the controller cables do not create a trip hazard on the floor between the controller and the mold machine or the injection unit.



### WARNING - ELECTRIC SHOCK HAZARDS

It is crucial to comply with these warnings to minimize any personal danger.

- Make sure that all energies are properly locked out in the controller and mold machine before installation of the injection unit into the system.
- Do not enter the controller cabinet without first isolating the supplies or having a qualified person selecting the bypass switch to on, to gain live access to the controller. There are unguarded terminals inside the cabinet which may have a dangerous potential across them. Where a three-phase supply is used, this potential may be up to 600 VAC.
- With the bypass switch set to off, opening the high power section of the controller will cause the circuit breaker to trip, disconnecting all power to the cabinet.
- The controller must be powered off before connecting or disconnecting servo cables. Heats should be off before connecting or disconnecting the heater cables.
- Integration should be done by properly trained personnel based on local codes and regulations. Electrical products may not be grounded when removed from the assembled or normal operating condition.

The injection unit controller should be located in such a way that the main disconnect is easily accessible in case of an emergency.

Controllers are shipped with a power cable that is the correct size to run the system. When you install a connector on the cable, make sure that the connector can safely withstand the full system load.

The controller power supply should have a fused disconnect or main circuit breaker according to local safety codes. Refer to the serial plate on the controller cabinet for confirmation of the main supply requirements. If the local supply is outside the specified range, please contact *Mold-Masters* for advice.

## **5.7 Operating Environment**

The controller should be installed in a clean, dry environment where the ambient conditions do not exceed the following limits:

- Temperature: 0 to +45°C
- Relative Humidity: 90% (non-condensing)

# Section 6 - System Setup



## NOTE

Read Section 3 - Safety Information on page 3-1 before setting up the E-Multi Mini.

## 6.1 Connecting the Controller to the Injection Unit

There are three sets of cables that connect the controller to the injection unit:

1. Two sets of servo power and feedback cables
2. A heater and I/O hybrid cable

The correct sequence must be followed when installing the cables. The servo power-feedback cables and heater and I/O cable need to be routed properly and secured before being connected to the motors. All cables must be routed to not interfere with the mold and the operation of the injection molding machine.

### 6.1.1 Routing and Connecting the Servo Cables



#### WARNING

Reversing the cables can result in unexpected and uncontrolled motion causing a safety risk or damage to the machine.

1. Uncoil the servo cables and make sure they are not damaged or twisted.
2. Route the servo power cables around the injection unit to the injection molding machine.
3. Connect the servo cables to the motors.
4. Use cable ties to hold the cables in place.

### 6.1.2 Routing and Connecting the Heater, I/O, and Injection Molding Machine Cables

1. Uncoil the heater and I/O cables and make sure they are not damaged or twisted.
2. Connect the "Injection Unit End" of the cable to the connector on the injection unit.
3. Connect the "Controller End" of the cable to the connector on the E-Multi mini controller.
4. Route the cables towards the motor end of the injection unit, taking care not to interfere with any moving parts or obstruct the pneumatic connections.

## 6.2 Connecting the Controller to a Robot

E-Multi Mini units are compatible with both E67 and SPI robots. In all cases, the controller is shipped with a robot jumper plug.

1. If no robot is used, connect the robot jumper plug to the “Robot E67” connector on the controller.
2. If an E67 robot is to be used, connect the robot’s E67 cable to the “ROBOT E67” connector on the controller.
3. If an SPI robot is to be used, attach the optional “Robot SPI Adapter” to the “Robot E67” connector on the controller, and connect the robot’s SPI cable into the “Robot SPI Adapter”.

## 6.3 Connecting the Controller to an Injection Molding Machine

Controllers are compatible with both E67 and SPI injection machines. All units ship with an injection molding machine E67 cable. The cable always connects to the injection molding machine E67 connection on the controller. If used with an E67 injection molding machine, the cable plugs into the injection molding machine’s E67 connection directly. If an SPI injection molding machine is used, the cable plugs into the optional Injection molding machine SPI adapter, which then plugs into the injection molding machine SPI connection.

## 6.4 Pneumatic Connections



### WARNING

Hoses fitted to the injection unit will contain air at ambient temperature and under pressure. The operator must shut down and lockout these systems as well as relieving any pressure before performing any work with these hoses.



### CAUTION

Using compressed air at pressures higher than 4.13 bar (60 PSI) will drastically shorten the life of the pneumatic vibrator. Damage to the vibrator as a result of using air pressure over 4.13 bar (60 PSI) is not covered under warranty.

1. Install a 6 mm tube fitting in the vibrator solenoid valve.
2. Connect a clean, dry, non-lubricated air supply, not exceeding 4.13 bar (60 PSI), to the quick-connect tube fitting.

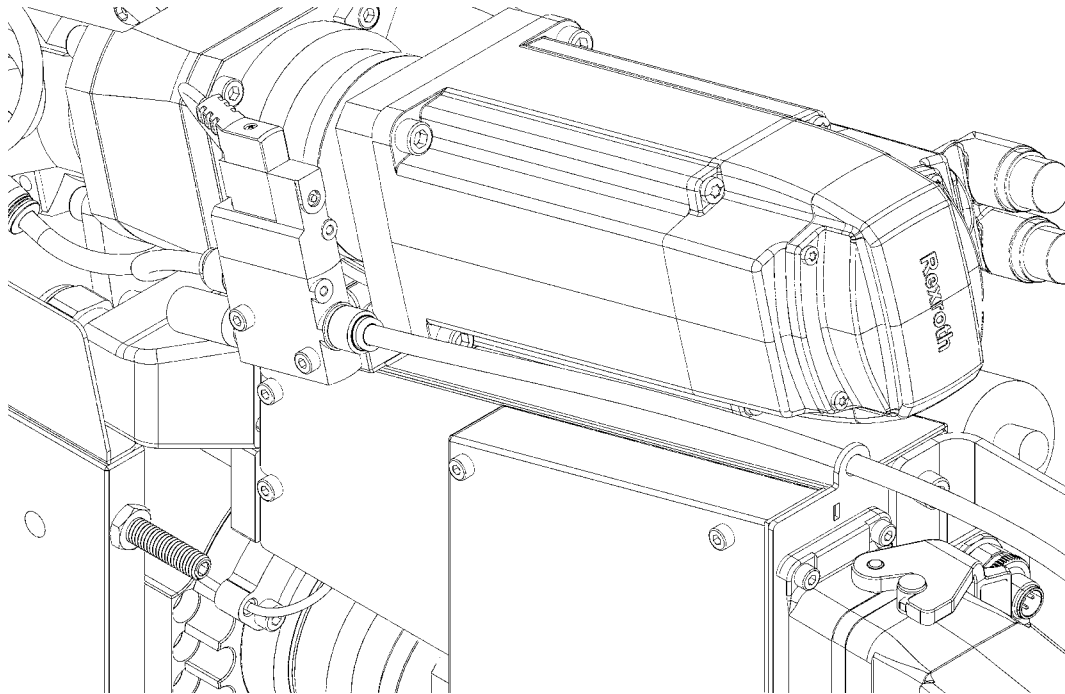

Figure 6-1 Pneumatic connections

3. Open the air supply slowly and check for leaks and repair if necessary.

### 6.5 Cooling Connections

All units have water-cooled housings to prevent overheating. Figure 7-2 shows the water inlet and outlet on the support beam.

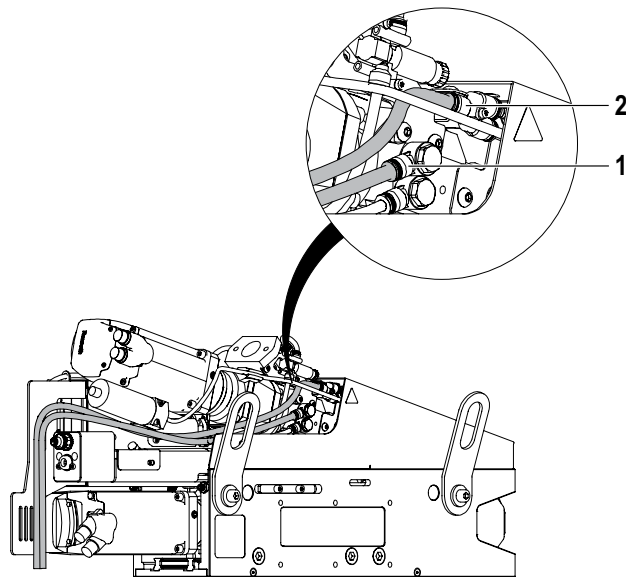

Figure 6-2 Cooling water supply and return

>>

For replacement parts, contact your local service representative.

Table 6-1 Cooling System Limits	
Property	Limits
Flow rate	3–6 liters (0.7–1.3 gallons) per minute
Maximum pressure	6 bar (87 PSI) at the beam fitting
Temperature	Minimum 5°C (41°F) above the dew point or at ambient temperature to prevent condensation. Maximum 50°C (122°F)

### 6.5.1 Cooling Water Schematic

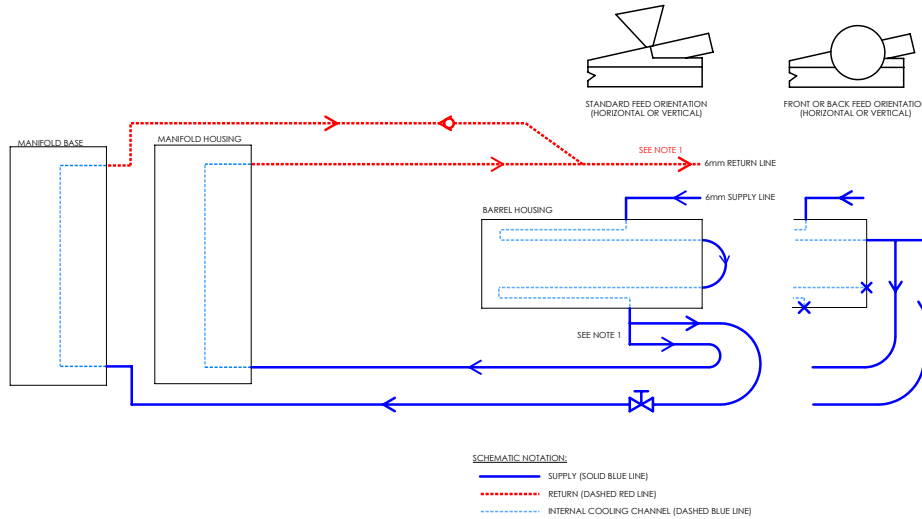

Figure 6-3 Cooling water schematic

### 6.5.2 Corrosion Caused by Condensation

Control the cooling temperature to prevent condensation on the injection unit. Condensation can cause corrosion of critical mechanical components. This damage is not covered by the warranty.

Install manual control valves or automatic temperature controls to make sure condensation does not occur.

### 6.5.3 Cooling Water Quality



#### CAUTION

Contaminated water will clog the cooling lines and may cause decreased cooling performance.

Table 6-2 Basic Water-Quality Specifications	
Property	Recommended Value
pH	7.2–8.5
CaCO <sub>3</sub> (ppm)	< 10
Ryznar Stability Index (RSI)	5.0–6.0
Temperature °C (°F)	5–25 (41–77)
Flow rate L/min. (oz)	3 (102)

The values in Table 6-2 Basic Water-Quality Specifications represent conditions that will prevent most problems associated with poor water quality. However, these recommended values do not guarantee that corrosion will not occur. More detailed water quality specifications can found in Section 11 - Cooling Water on page 11-1.

# Section 7 - Controller Operation



## NOTE

Read Section 3 - Safety Information on page 3-1 before setting up the E-Multi Mini.

## 7.1 Introduction

Before the injection unit can be used, the controller must be set up. Please see Section 9 for details on setting parameters such as:

- Heating
- Control
- Injection speeds
- Trigger signals

## 7.2 Controller Startup and Shutdown



### CAUTION

The controller should not be powered off when running in automatic mode unless there is an emergency.

The controller uses computer technology and should be switched off in stages. A sequenced method for switching on and off protects the console and keeps the switched load to a minimum to extend the life of the main isolator.

For all controllers, the main power switch is a rotary circuit breaker at the rear of the cabinet. This switch is rated to safely disconnect the total load current during switch off. You can use a suitably-sized padlock, or similar device to lock the switch in the off position to lockout electrical supply during maintenance.



Figure 7-1 Main power switch

### **7.2.1 Controller Startup**

When the main power switch is turned to on, the servo motors will not be enabled. Once the software has finished loading and the display shows the Overview page, the system is in Manual mode and is ready to have the heaters switched on to heat the barrel heaters.

Servo motors may be enabled by pressing the Motor icon on the top left corner of the touchscreen. Once the servo motors are enabled, the Motor icon at the top left of the button will turn green. The E-Multi controller can be used in Manual, Setup or Auto/Ready mode.

### **7.2.2 Controller Shutdown**

Mold-Masters recommends turning off the barrel heats and disabling the servo motors and then powering off the controller using the main power switch.

#### **7.2.2.1 Turning Off the Heating**

Press the Heat icon on the touchscreen to turn the heating on. The LED at the top left of the Heat icon indicates the heating status. If the LED is lit, the heating is active. Any error or warnings associated with the heating function will be displayed on the status bar on the touchscreen.

#### **7.2.2.2 Turning Off the Controller**

Once the barrel heats and servo motors have been turned off, the system may be turned off using the main power switch on the back of the controller.

# Section 8 - Maintenance



**NOTE**

Read Section 3 - Safety Information on page 3-1 before doing maintenance on the E-Multi Mini.

## 8.1 Preventive Maintenance Schedule

Table 8-1 Preventive Maintenance Schedule	
Preventive Maintenance	Frequency
Clean unit, remove spilled plastic pellets and any accumulated drool from nozzle	Start of every shift
Controller fan filters	Check monthly, replace if necessary
Check for water leaks.	Start of every shift
Check for condensation on external surfaces	Start and end of every shift
Lubricate linear guides	Check every three months, and add lubrication if necessary
Lubricate ball screws	Check every three months, and add lubrication if necessary
Lubricate ball screw nut	Check every three months, and add lubrication if necessary

## 8.2 Torques

### 8.2.1 Screw Torques

Refer to your assembly drawings for fastener torques. When the torques are not listed on the assembly drawings, refer to the following table.



**WARNING**

All screws must conform to DIN 912 (socket-head cap screws) and ISO 12.9 (grade 12.9) unless noted otherwise. Using low quality screws can result in screw failure and potentially serious injury.

Table 8-2 Screw Torques		
Fastener Type and Size	Nm	in-lbs
M6 Captive	10	89
M6 Socket-head cap screw	16	140
M4 Flat head	2.3	20
M5 Flat head	5.5	49
M6 Socket-head cap screw	16	140
M5 Button head	5.5	49
M6 Button head	10	89
M4 Button head	2.8	25

>>

Table 8-3 Screw Torques Continued		
Nominal Thread Size	Nm	ft-lbs (in-lbs)
M4	4.6	3.4 (40.8)
M5	9.5	7 (84)
M6	16	11.5 (138)
M8	39	29 (348)
M10	58	42.5 (510)
M12	101	75 (900)
M14	161	119 (1428)
M16	248	182 (2184)
M20	488	360 (4320)
M24	825	608 (7296)



**WARNING**

Adaptor plate screws should be retightened after an initial run of one shift (approximately eight hours). Adaptor plate screws should be retightened again after one week of service.

**8.2.2 Other Torques**

Table 8-4 Nozzle Tip Torque			
Description	Model	Nm	lb-ft
Nozzle Tip	All	135	99.5

## 8.3 Lubrication

### 8.3.1 Lubrication Guidelines

Table 8-5 Lubrication Guidelines				
Location	MM Part No.	Type	Manufacturer	Manufacturer's Part No.
Drive Shaft Bearings Linear Guides Ball Nuts	104L11111	Spindle bearing lubrication	Klüber Lubrication	ISOFLEX NBU 15
		Barium based thickening agent	Klüber Lubrication	Staburags NBU 8EP
		Lithium based thickening agent	Klüber Lubrication	Klüberplex BEM41-141
Injection Ball Screw Nuts	n.a	Spindle bearing grease	Klüber Lubrication	ISOFLEX NBU 15. No exceptions allowed
General Assembly	104L11111	Soap-based lithium lubrication	Klüber Lubrication	ISOFLEX NBU 15
			Shell	Gadus S2
			Loctite	30530
		Barium based thickening agent	Klüber Lubrication	Staburags NBU 8EP
		Lithium based thickening agent	Klüber Lubrication	Klüberplex BEM41-141
Aluminum based thickening agent	Lubcon	Thermoplex ALN 1001		
High-Temperature Bolts Barrel-to-Housing Feed Block Retaining Bolts Screw Drive Gearbox Output Shaft	n.a.	Anti-seize compound, silver grade	Loctite	767

>>

Location	MM Part No.	Type	Manufacturer	Manufacturer's Part No.
Screw (Drive End)				
Actuator Rod End Actuator Link Vibrator Mounting Screws	n.a.	Thread lock compound, removable	Loctite	242 243
Tapered Plugs	n.a.	Pipe thread sealant	Loctite	567

### 8.3.2 Lubricating the Injection Ball Screw

**CAUTION**

Make sure to use the recommended grade of lubrication.

There are three lubrication ports located on the side plate.

1. Remove the three port plugs.

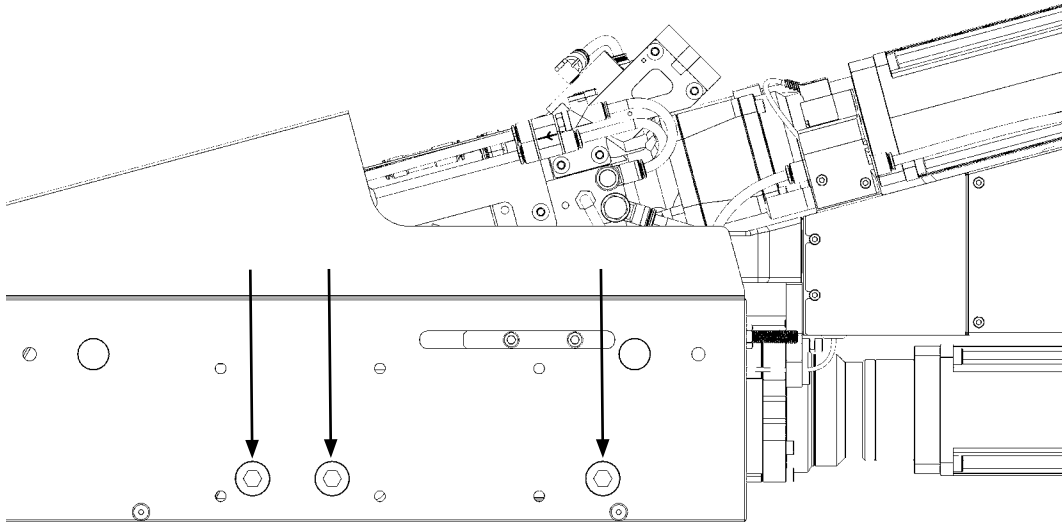

Figure 8-1 Removing the port plugs

**NOTE**

If you cannot find the locations of the lubrication fittings, refer to the installation drawing provided with your E-Multi Mini.

2. Using the controller carriage controls, position the injection unit so that the lubrication fitting of the injection ball screw is accessible.
3. Make sure that the lubrication fitting is clean.

>>

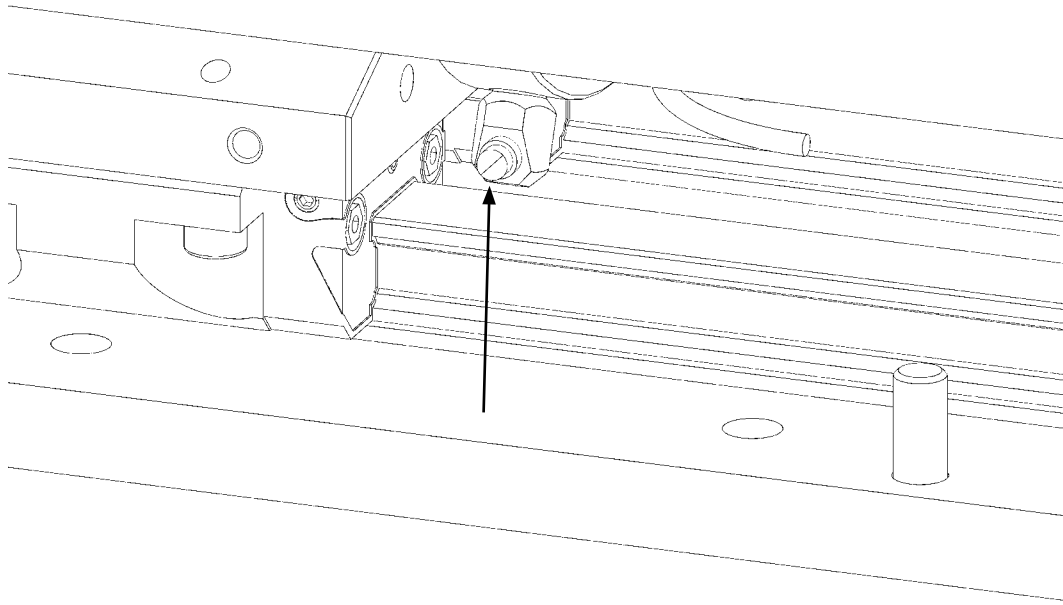

*Figure 8-2 Lubricating the injection ball screw*

4. Use a lubrication gun to insert lubrication through the lubrication fitting.

### 8.3.3 Lubricating the Linear Guides

There are six lubrication fittings with corresponding access ports on both sides of the support beam (3x2).

1. Move the carriage forward or backward using the controller until you can access the lubrication fitting.
2. Make sure that the lubrication fitting is clean.
3. Use a lubrication gun to insert lubrication through the lubrication fitting.

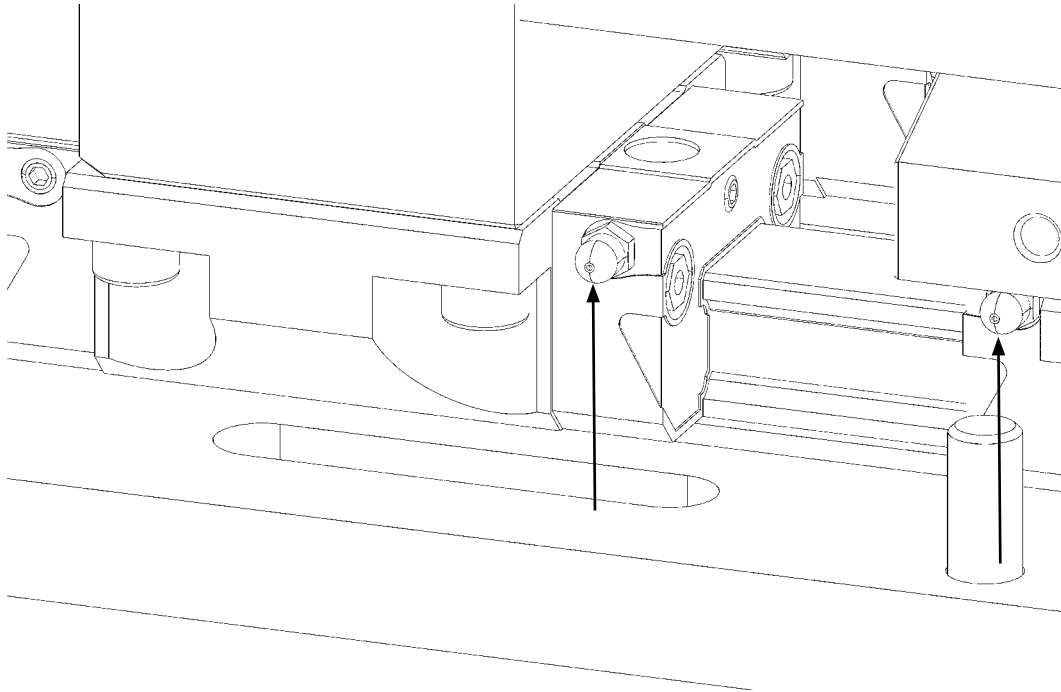

*Figure 8-3 Lubricating the linear guides*

## 8.4 Purging Plastic from the System



### WARNING - BURN HAZARD

Material purged from machine will be extremely hot. Make sure protective guards are in place around the nozzle to prevent molten plastic from splashing. Use proper personal protective equipment.



### CAUTION

Leaving a rotating screw unattended may result in serious damage to the screw, barrel, and ring check.

Refer to Figure 8-13 Controller main page on page 8-18 for the locations of the on-screen buttons.

Before doing the procedure that follows, make sure that no further raw material is entering the system through the feed port.

1. Turn on the barrel heats and allow them to reach operating temperature.
2. Turn on the servo motors and allow the auto soak routine to complete.
3. Put the controller in manual mode.
4. Using the carriage-motion back button, retract the nozzle from the mold inlet to a position where there is sufficient room for purging material to flow away from the inlet area.
5. Put the controller in setup mode.
6. Make sure that the injection plunger position is retracted to allow material to flow through the manifold.
7. Press and hold the screw rotation button. The screw will rotate continuously while the button is held.
8. Continue to hold the screw rotation button until no more material flows from the nozzle, and release the button to stop the screw motion.
9. Press the injection forward button to move the plunger forward, which will force out any remaining material in the plunger bore in the manifold.
10. Turn off the servo motors.
11. Turn off the barrel heats.

## 8.5 Purging Cooling Water from the System



### **WARNING - BURN HAZARD**

Water contacting the hot barrel quickly becomes extremely hot and is a burn hazard. Purge hot plastic from the system and cool the barrel before disconnecting water cooling fittings.



### **WARNING**

Use compressed air safely.



### **CAUTION**

Do not get water on unpainted surfaces such as ball screws, barrel, and feed screw as they will rust.



### **CAUTION - HEAT DAMAGE**

Never run the system without water cooling. Serious damage to the machine will result.

1. Turn off the water supply and disconnect the supply lines. Disconnect the return line and place in a bucket or other suitable container.
2. Using low pressure (< 50 psi) compressed air, blow air into the supply line until no more water comes out of the return line.
3. Check the cooling lines on the machine to make sure no water remains.

## 8.6 Removing the Injection Unit for Maintenance

1. Purge plastic from the system.
2. Retract the carriage so that the nozzle tip is on the injection unit side of the adapter plate.
3. Secure the machine with the appropriate lifting equipment. See Table 8-3 Screw Torques Continued on page 8-2.
4. Remove the bolts and separate the injection unit from the injection molding machine.
5. Purge cooling water from the system.
6. Disconnect the water, pneumatic, I/O, heater and motor connections from the injection unit.
7. Place the injection unit in the horizontal position on a work bench or machine maintenance stand capable of supporting the full machine load.

## 8.7 Replacing the Adapter Plate



### NOTE

Adapter plates are specific for each injection unit and mold pair. The adapter plates may not be as shown.

### 8.7.1 Method 1: Manual Nozzle-Concentricity Adjustment

1. Purge the system of plastic and cooling water.
2. Place the injection unit in the horizontal position on a work bench or machine maintenance stand capable of supporting the full machine load.
3. Connect the injection unit to the controller and power up the injection unit. Use the controller to move the carriage so the nozzle tip is flush with the face of the adapter plate, if possible.
4. Remove the adapter plate screws and remove the adapter plate.

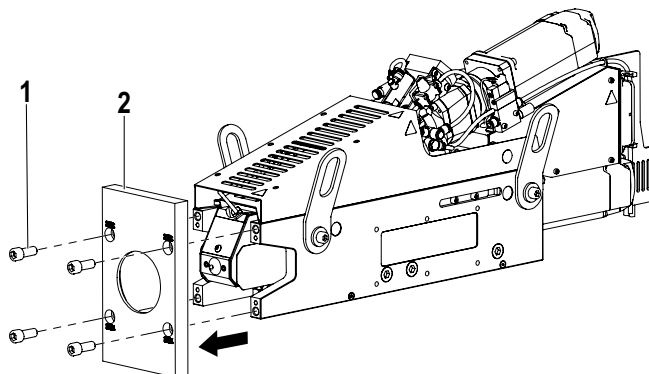

Figure 8-4 Removing the adapter plate

Table 8-6 Adapter Plate Components	
Position	Part
1	Adapter plate screws
2	Adapter plate

5. Use solvent to clean the mating surfaces of the replacement adapter plate and support beam. Wipe with a clean, lint-free cloth.
6. Apply a light coat of oil to the contact surfaces.
7. Install the adapter plate but leave the screws loose.
8. Tighten the bolts lightly so that the adapter plate can be moved by tapping with a rubber mallet.

>>

9. Measure the distance from the nozzle to the adapter plate bore at the 12, 3, 6 and 9 o'clock positions and align the plate by tapping so the distance is equal at all positions. See the following drawing.

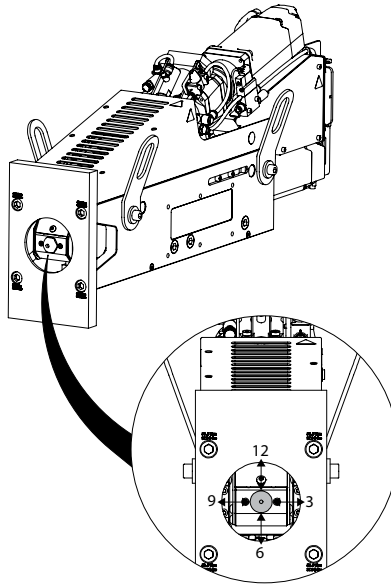

*Figure 8-5 Nozzle*

10. Tighten the adapter plate screws in cross pattern. See Table 8-3 Screw Torques  
Continued on page 8-2.
11. Set the correct nozzle protrusion for the mold being used. See the following drawing.  
See also Section 8.9 Calibrating the Linear Carriage Actuator on page 8-15.

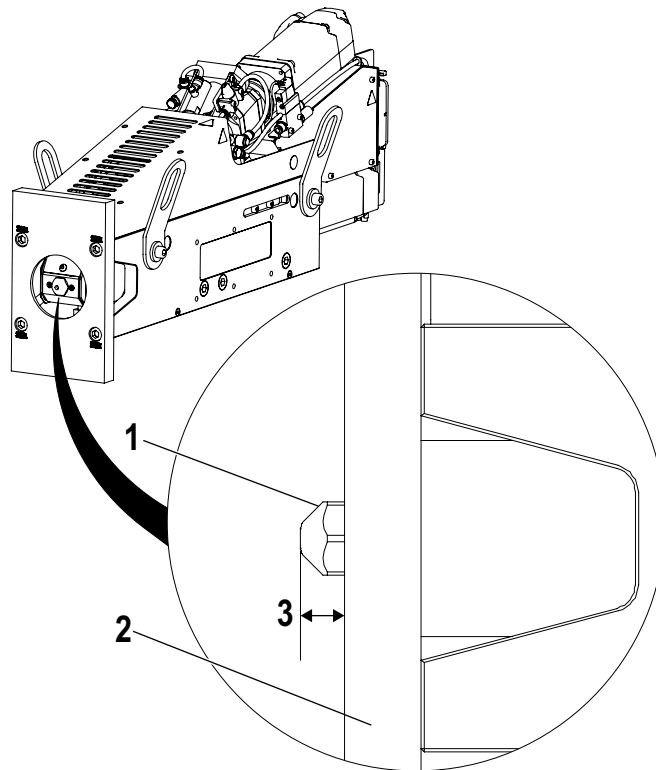

*Figure 8-6 Nozzle protrusion*

Table 8-7 Nozzle Protrusion	
Position	Part
1	Nozzle tip
2	Adapter plate
3	Nozzle protrusion

12. Tighten the clamping screws to the proper torque. See Table 8-3 Screw Torques  
Continued on page 8-2.

13. Connect the injection unit to the controller and use the controller to move the carriage.  
The injection unit is ready to install on the mold.

### 8.7.2 Method 2: Concentricity Adjustment Using an Alignment Tool

1. Purge the system of plastic and cooling water.
2. Place the injection unit in the horizontal position on a work bench or machine maintenance stand capable of supporting the full machine load.
3. Connect the injection unit to the controller and power up the injection unit. Use the controller to move the carriage so the nozzle tip is flush with the face of the adapter plate, if possible.
4. Remove the adapter plate screws and remove the adapter plate.

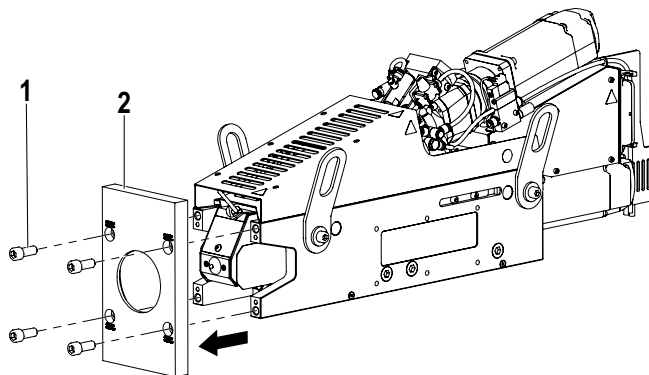

Figure 8-7 Removing the adapter plate

Table 8-8 Adapter Plate Components	
Position	Part
1	Adapter plate screws
2	Adapter plate

4. Remove the replacement adapter-plate shipping bracket, if necessary.
5. Use solvent to clean the mating surfaces of the replacement adapter plate and support beam. Wipe with a clean, lint-free cloth.
6. Apply a light coat of oil to the contact surfaces.
7. Install the adapter plate but leave the screws loose.

>>

8. Install the alignment tool in the bore or the locating pin holes in the adapter plate and onto the outside of the hexagonal part of the nozzle tip.
9. With the alignment tool in place, lightly tighten the screws holding the adapter plate to the side plates.
10. Remove the alignment tool.

## 8.8 Replacing the Injection Nozzle



### CAUTION

The injection nozzle area should be kept clean of debris, dust, and plastic.

1. Clean the nozzle and barrel area. Remove any plastic residue, using soft brass tools only.
2. Remove the nozzle tip. See the following drawing.

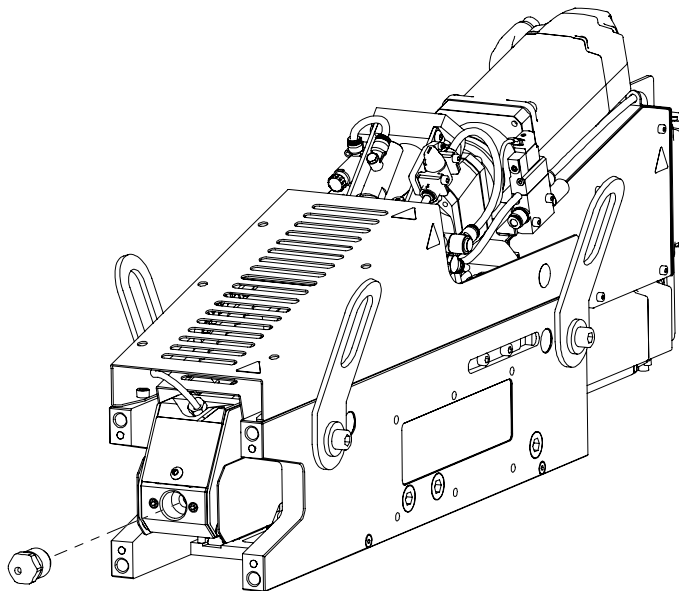

3. Clean any plastic from the nozzle opening and inner cone.
4. Apply anti-seize compound to the nozzle tip threads and re-install the nozzle tip. Tighten the nozzle tip to a torque of 135 Nm (99.5 lb-ft).



### NOTE

Because of variations in the nozzles, when a nozzle is changed, the adapter plate should be re-aligned as described in Section 8.7 Replacing the Adapter Plate on page 8-10.

## 8.9 Calibrating the Linear Carriage Actuator



### WARNING

If the injection unit is mounted vertically, it may drop when the fasteners are loosened.

1. In the controller user interface (UI) navigate to the Carriage page along the top bar:



Figure 8-8 Main carriage page

2. Enter the Carriage Setup Menu:

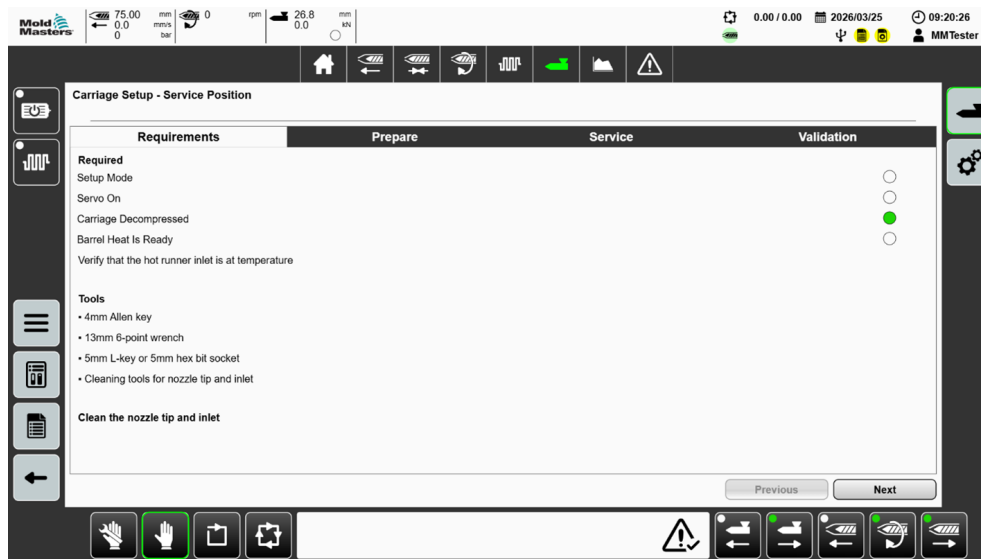

Figure 8-9 Carriage setup menu

3. Ensure all requirements are met:

- Setup Mode is engaged.
- Servo Motors are On.
- Carriage is Decompressed.
- Barrel Heats are at temperature.
- Hot runner inlet is at temperature.

>>

4. Prepare tools as shown.
5. Clean the nozzle tip and inlet as instructed.
6. Press [Next] to continue to the “Prepare” screen:

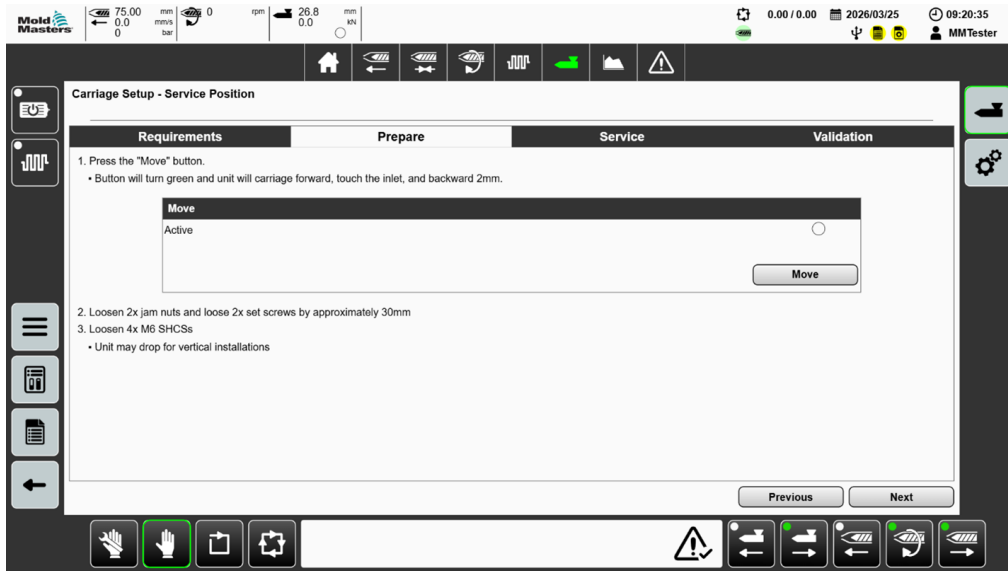
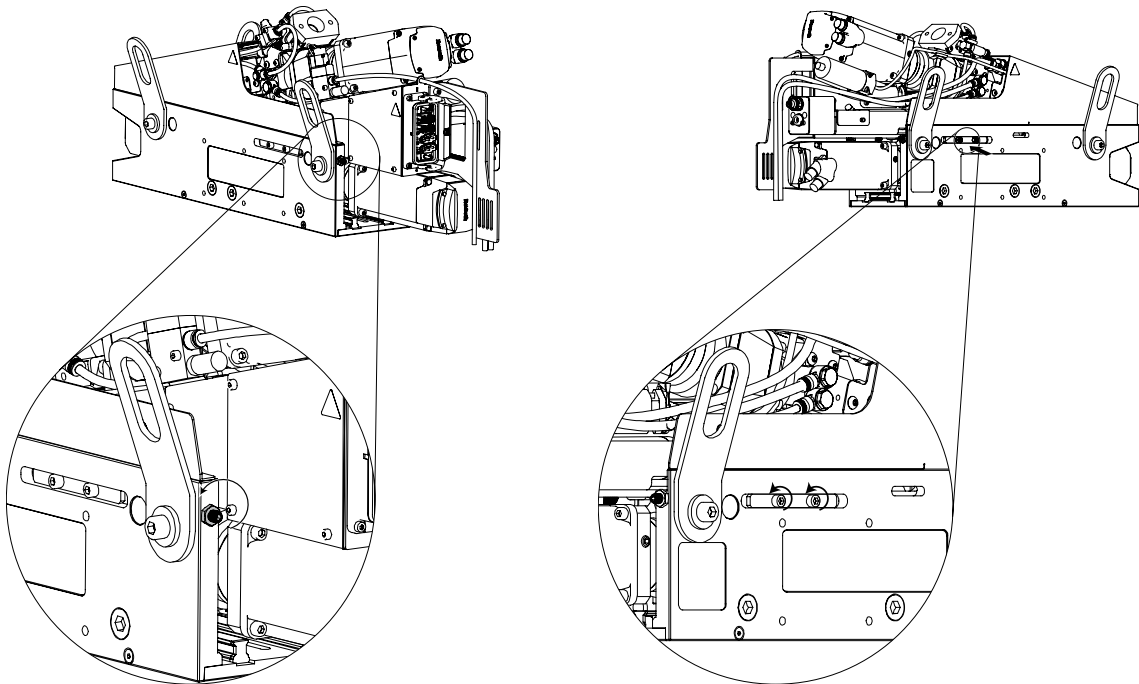

Figure 8-10 Carriage setup menu - Prepare screen

7. Follow the instructions on screen, steps 1 through 3. Images below shows the fastener locations:



>>

8. Press [Next] to continue to the “Service” screen:

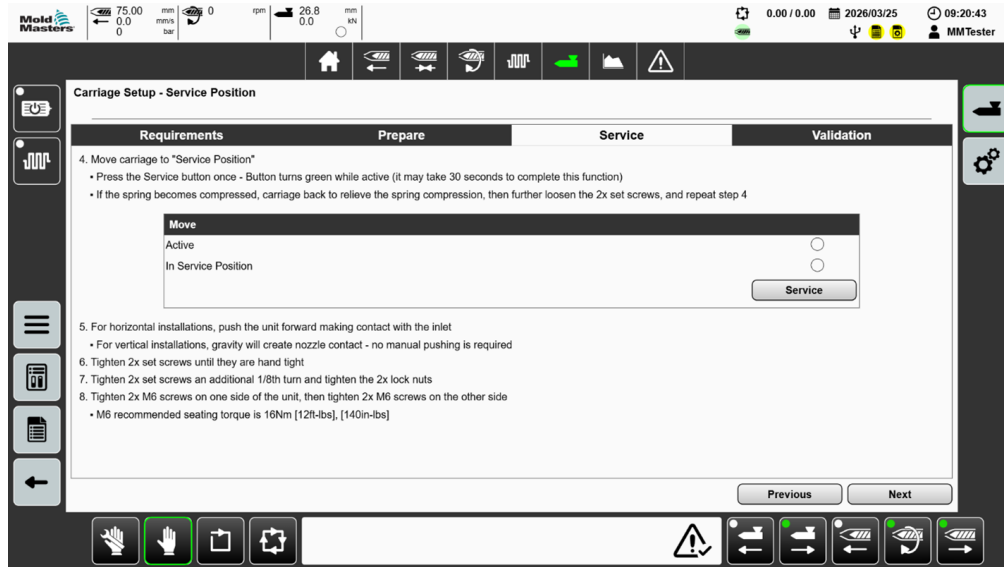

Figure 8-11 Carriage setup menu - Service screen

9. Follow the instructions on screen, steps 4 through 8.

10. Press [Next] to continue to the “Validation” screen:

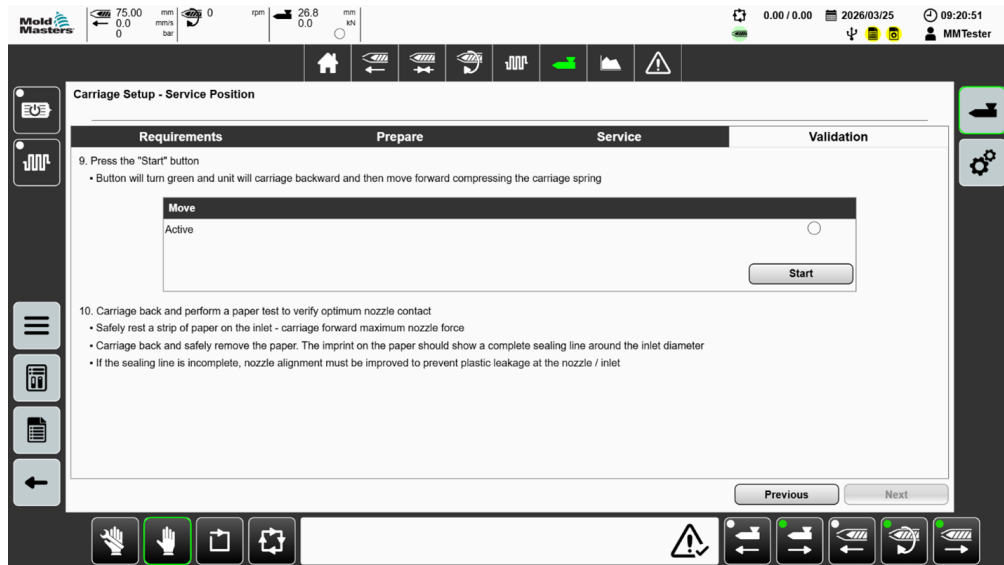

Figure 8-12 Carriage setup menu - Validation screen

11. Follow the instructions on screen, steps 9 through 10 to confirm that carriage set up and calibration has successfully completed.

## 8.10 Referencing the Injection Axis

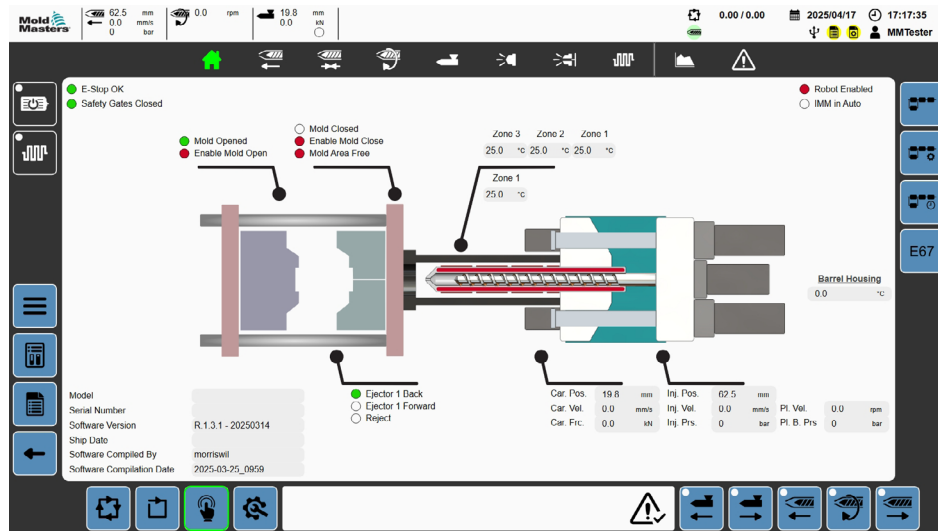

Figure 8-13 Controller main page

The servo motors should be referenced when the:

- system is first commissioned
- injection motor is removed or replaced
- injection gearbox is removed or replaced
- injection ball screw is removed or replaced
- injection servo drive is replaced
- injection plunger is replaced
- controller displays a message saying that referencing is required

### IMPORTANT

The injection referencing routine verifies the injection stroke by moving the screw fully back and then fully forward. Referencing will fail if the screw cannot achieve the full stroke.

Before doing the following procedure, the controller must be in Setup mode with heats on and at operating temperature, carriage referenced, and carriage retracted from the mold.

>>

- Using the controller touchscreen, go to the Calibration page.

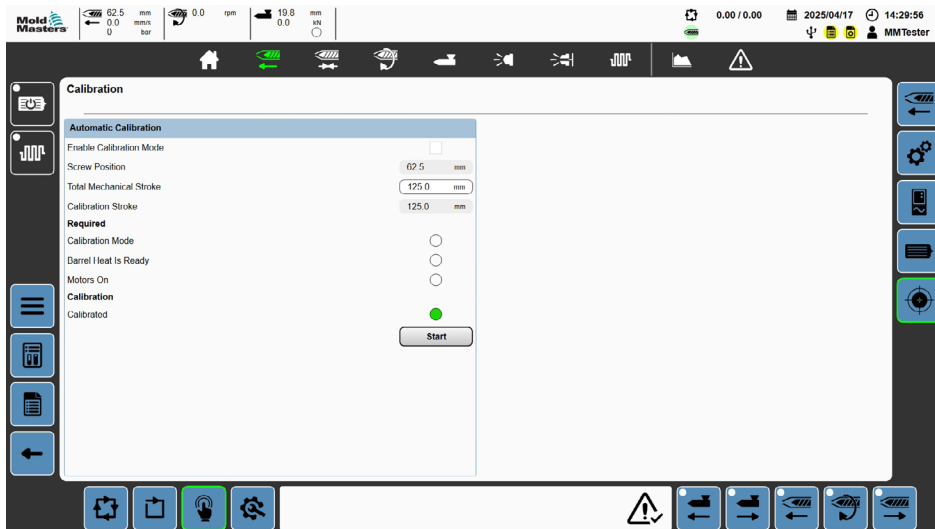

Figure 8-14 Calibration page

- Tap the Reference button in the lower left-hand area, and confirm the dialog box that appears.
- Wait for the screw to move fully back and then fully forward. Referencing is complete when the screw position is 0 mm.

## 8.11 Removing the Hopper



### **WARNING - BURN HAZARD**

Make sure that the extruder assembly is cool before doing the procedure that follows.

- Make sure that the hopper is empty.
- Remove the two M8 fasteners that attach the hopper to the extruder assembly.
- Carefully lift and remove the hopper from its position.

## 8.12 Replacing the Vibe Tube Assembly

The barrel should be purged before the assembly is changed. See Section 8.4 Purging Plastic from the System on page 8-8. Pellets should be removed using a vacuum cleaner to prevent pellets from spilling onto the machine.

### 8.12.1 Removing the Feed Assembly

1. Disconnect any connections to the feed system.
2. Do the procedure of 8.11 Removing the Hopper on page 8-19
3. Disconnect the air line from the push-connect fitting on the vibrator.
4. Remove the four M6 button head fasteners, two on each side, that attach the vibrating tube flange.
5. Remove the vibrating tube flange.
6. Remove the four M5 shoulder screws that attach the vibrator tube, and remove the vibrator tube along with the vibrator.

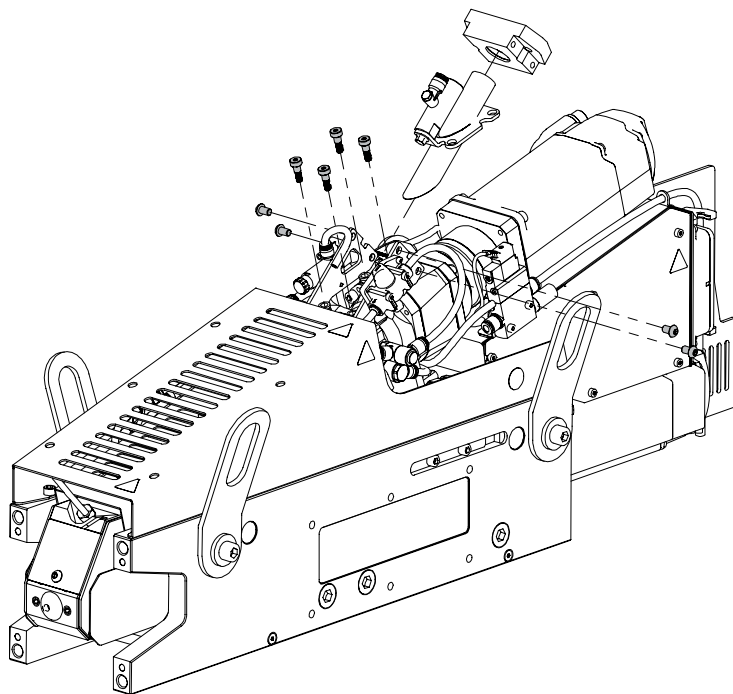

Figure 8-15 Removing the feed assembly

7. If pellets have not purged from the unit, use a vacuum cleaner to remove the pellets from the barrel housing and barrel.

### 8.12.2 Installing the Vibe Tube Assembly

Installation is the reverse of removal except lubricate O-ring with silicone grease prior to reassembly to ease installation of the flange onto the Vibe Tube.

## 8.13 Cleaning and Replacing the Feed Screw



### WARNING

The following procedure is done in the hot condition. Wear appropriate personal protective equipment such as heat resistant gloves and goggles or a face shield. Failure to do so can result in serious injury.

### 8.13.1 Preparing for Feed Screw Removal

The following procedure requires the injection unit to remain connected to and operable by the controller, as the screw motor will need to run a maintenance routine through the controller software. Additionally, the extruder barrel must be heated to remove the screw from the extruder.

1. Use the controller if necessary, to position the carriage so that the two rightmost screws are accessible (see below).

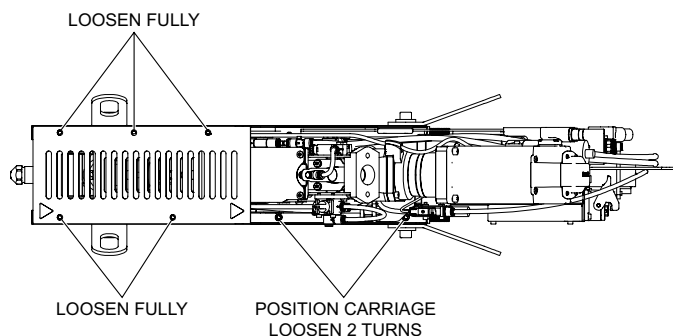

2. Remove the top cover of the E-Multi Mini. See Figure 8-16 Removing the top cover.

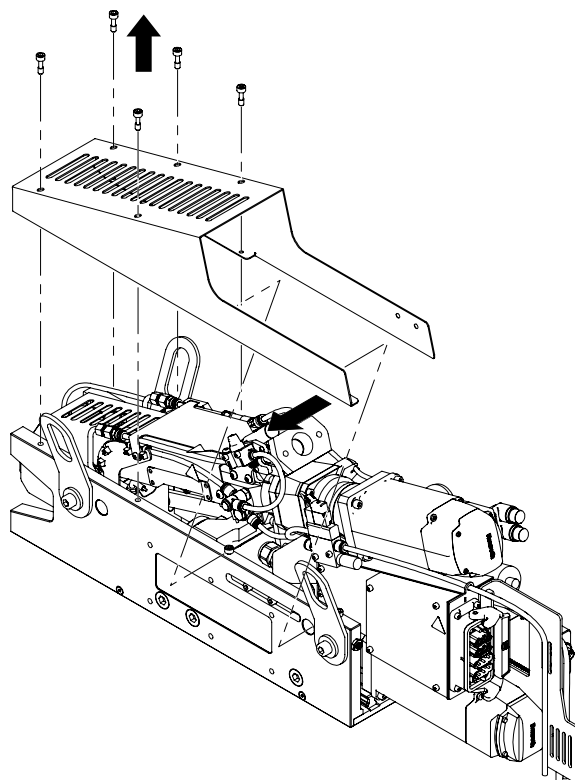

Figure 8-16 Removing the top cover

### 8.13.2 Removing the Feed Screw



#### WARNING

The following procedure is done in the hot condition. Wear appropriate personal protective equipment such as heat resistant gloves and goggles or a face shield. Failure to do so can result in serious injury.



#### CAUTION

Do not remove the two M5 fasteners that hold the barrel housing to the support bracket.



#### CAUTION

Only the following procedure should be used to decouple the screw. Turning the screw for more than the small amount required for decoupling may cause damage to the unit.

1. Use the controller touchscreen to do the screw removal procedure. This will rotate the screw in the opposite direction to decouple the drive shaft and the screw coupling. See the following image.

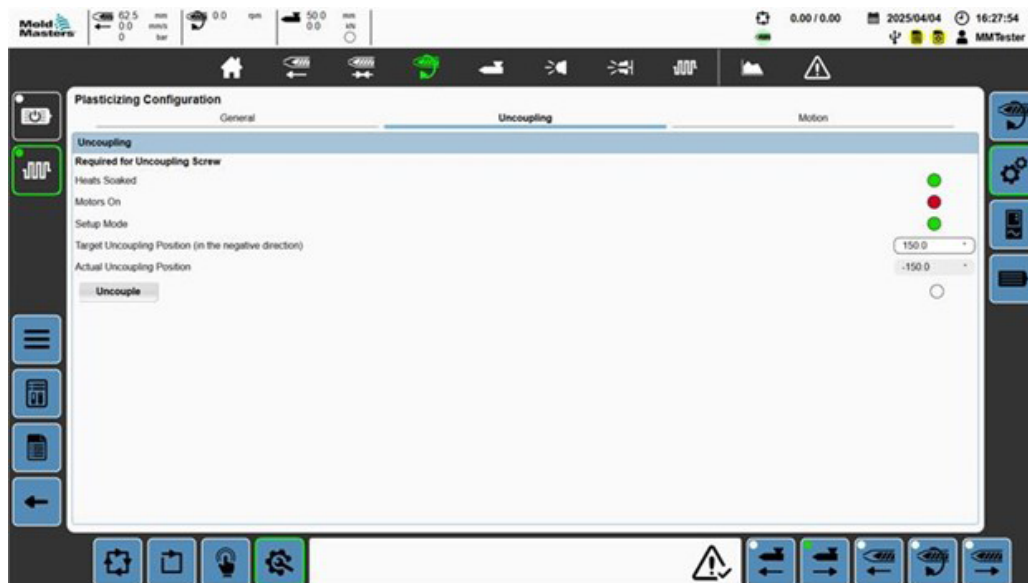
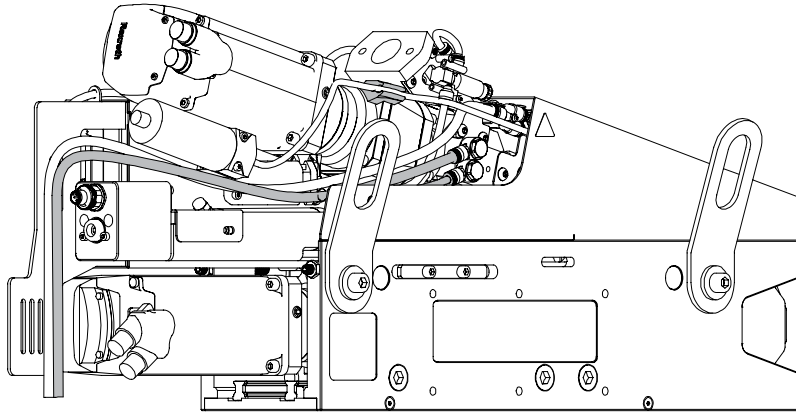

Figure 8-17 Uncoupling page

2. Move the carriage back to a position where the cover screws are accessible (see section 8.13.1). Power down and lock out and tag out the injection unit. For additional clearance it may be easier to access the fasteners with the top cover removed - see section 8.13.1
3. If necessary to access the four M6 screws shown below, Drain the water and disconnect the water and air connections lines from the injection unit.
4. Carefully unclip the pressure transducer capillary tube from the retaining clip. See the following drawing.

>>



- Remove the four M6 fasteners (M6X20 and M6X30 on each side) that connect the barrel housing and the bearing housing. The two lower screws may not need to be fully removed as long as they are fully clear of the tapped holes. See the following drawing.

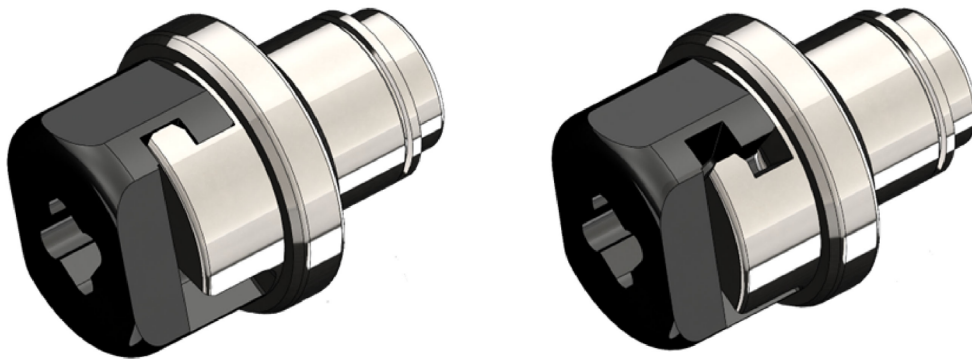
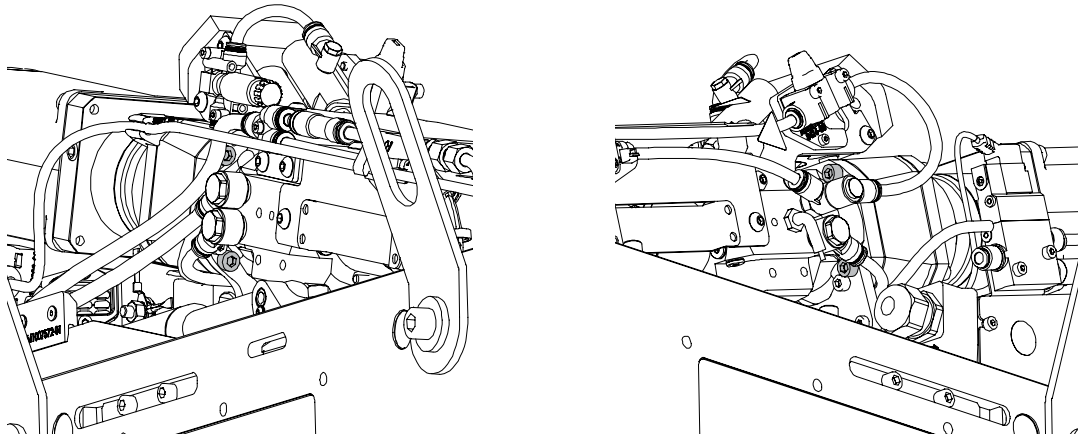

*Figure 8-18 Coupled screw (left) and uncoupled screw (right)*

- Remove the bearing housing, gearbox, and servo motor as a single assembly. Do not separate these components during removal. See the following drawing.

>>

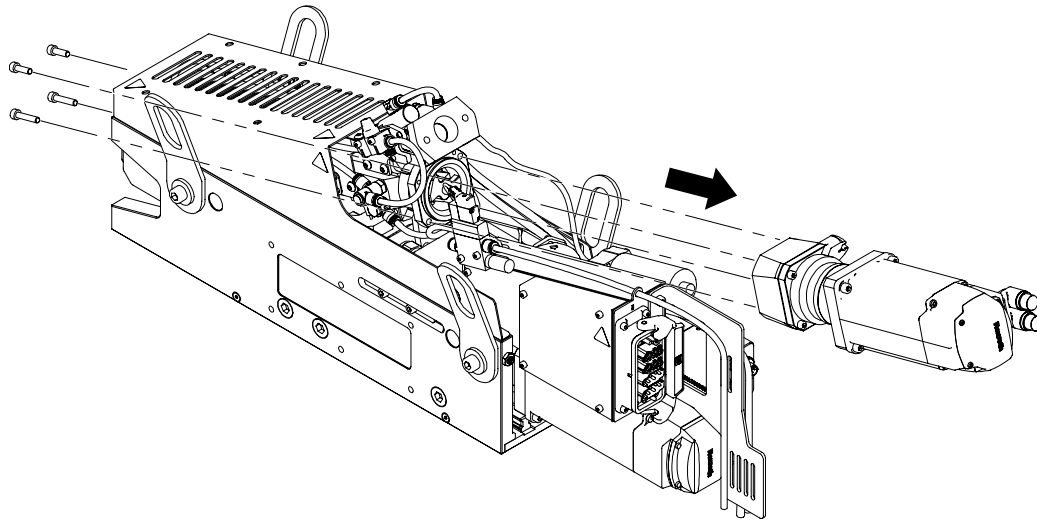

7. Remove the screw coupling and the feed screw from the extruder barrel.
8. Remove the M6X10 fastener that connects the screw coupling and the feed screw. See the following drawing. Use a wrench or soft-jaw vice to hold the coupling half while removing the socket-head cap screw.

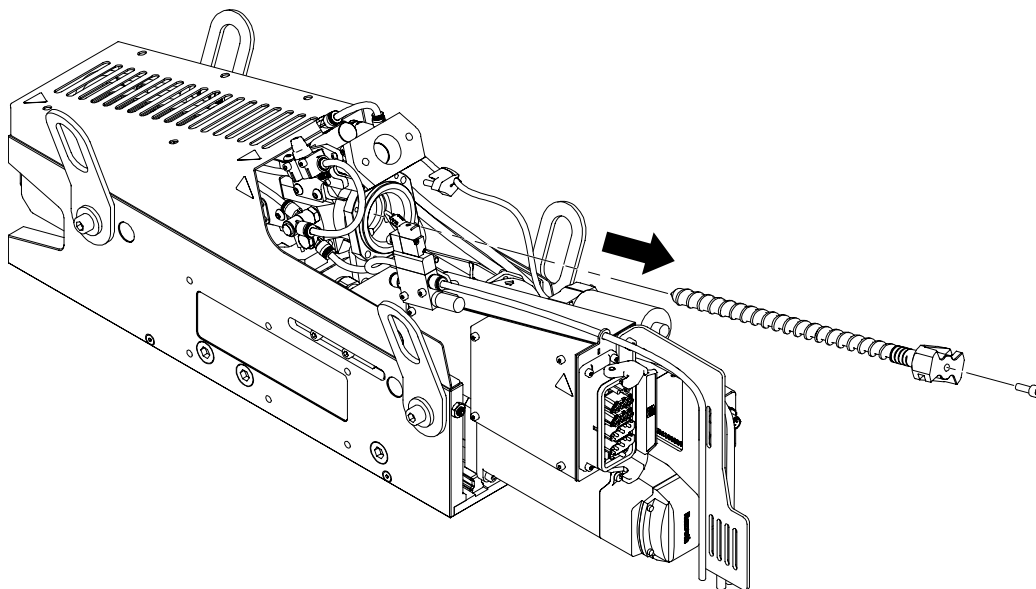

### **8.13.3 Cleaning the Feed Screw**

9. Use a brass bristled brush to clean plastic from the feed screw.

### 8.13.4 Installing the Feed Screw

**NOTE**

Refer to the torque table for the installation torques.

1. Apply anti-seize compound to the threads of the screw collar fastener (M6X20).
2. Install the M6X20 fastener that connects the screw coupling and the feed screw and tighten to a torque of 16 Nm (140 in-lbs).

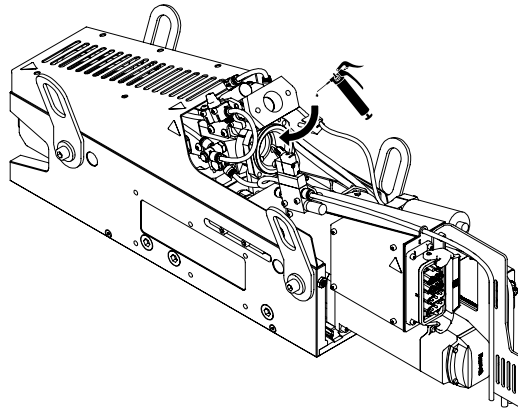

3. Inspect the bore of the barrel and remove any remaining plastic from the bore using a brass brush if necessary prior to installing the feed screw.
4. Install the feed screw assembly into the extruder barrel. See the following drawing.

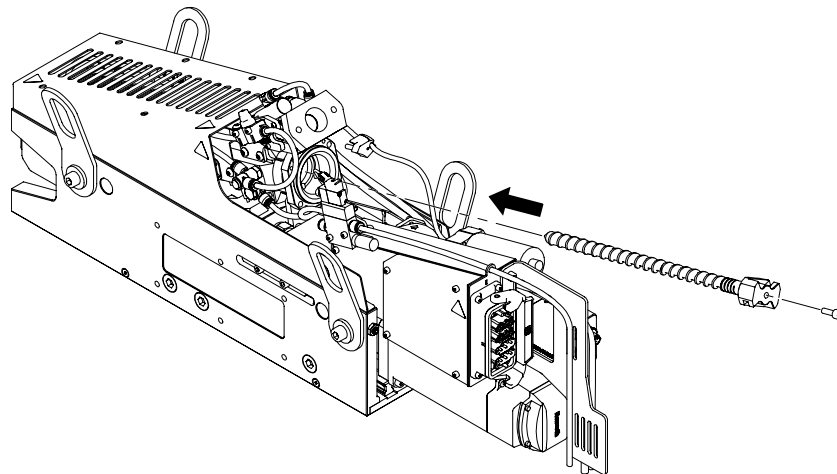

5. Make sure that the feed screw is correctly installed in the extruder barrel. The coupling should be able to make contact with the housing when the feed screw is fully inserted. If the screw cannot be fully inserted, remove it and remove any remaining contamination from the bottom of the barrel bore.

>>

6. Install the servo motor assembly. See the following drawing.

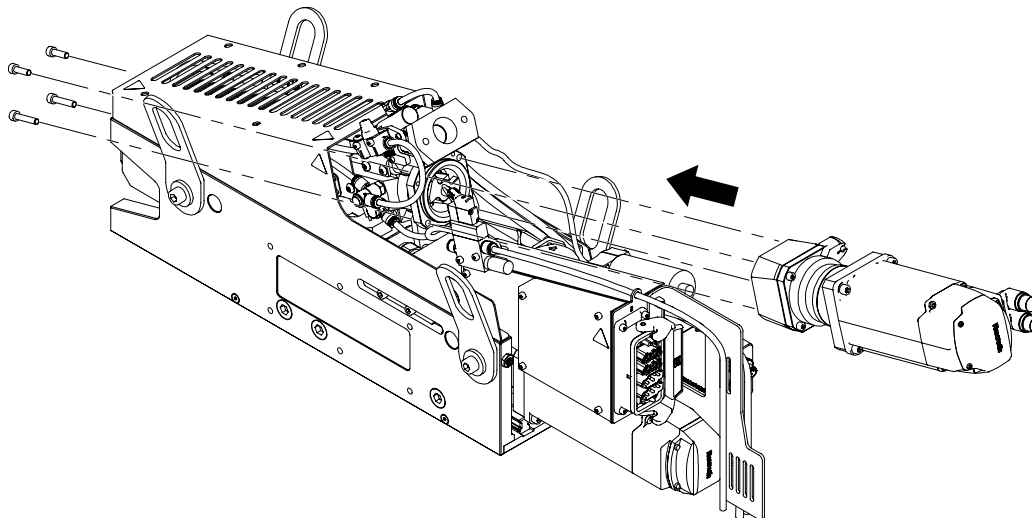

7. Install the four M6 fasteners (M6X20 and M6X30) connecting the barrel housing and bearing housing. Use a hex key to tighten the M6 fasteners to a torque of approximately 16 Nm (140 in-lbs).
8. Make sure that the screw coupling is aligned with the drive shaft. It can be helpful to pull the screw partially out of the barrel, manually engage the coupling halves together, and then use the screw to guide the servo motor assembly into place.
9. Connect the water and air lines to the injection unit. Make sure that all connections are secure and that there are no loose components, and check for leaks.
10. Install the top cover. See the section 8.13.1.
11. Re-connect the servo cables to the extruder motor.

# Section 9 - Component Tests and System Alarms



## WARNING

Make sure that you have fully read Section 3 - Safety Information on page 3-1 before performing any of the tests in this Section.

You are responsible to protect yourself from shock by indirect contact, by ground connections and automatic disconnection of the power supply. Mold-Masters components and systems are either equipped with a ground connection, or there is a connector for this purpose.

## 9.1 Thermocouple Electrical Test

The controller system can monitor thermocouple performance. A working thermocouple will show a realistic temperature based on its environment. Defective thermocouples will read an abnormally high or negative value on the controller.

Thermocouples should show output similar to those in the same area.

1. If a thermocouple shows as defective, test the thermocouple at the injection unit electrical connector A as per the schematics. Check the resistance level between pins 1-7,2-8,3-9,4-10, 5-11, 6-12 on connector A, and pins 6-12 on connector B. If the output is significantly different, replace the thermocouple.
2. If the new thermocouple still shows an abnormally high or negative value, check the wiring and connections.

## 9.2 Heater Continuity Test



## WARNING

The following procedure requires access to the heater connector. Power down the machine before disconnecting the heater cable.

Testing of the heaters is done with a multimeter set to measure resistance. The heaters are wired to the connector in pairs.

Check the resistance across the pins 1-2, 3-4, 5-6. The multimeter should show about 260  $\Omega$  for barrel heaters between pins 1-2 and 3-4 and 30  $\Omega$  for the manifold heater between pins 5-6. A reading of 0  $\Omega$  indicates a shorted heater and a reading of infinity indicates an open heater.

### 9.3 Transducer Output Alarm

The transducer function is checked automatically every cycle. If the transducer is defective, the controller will show an alarm.

### 9.4 Control System Alarms

The control system has several features which provide an early diagnosis of faults in the control system.

- If the system detects any malfunctions, it displays an **error** message on the Alarm screen.
- If the system detects any abnormal condition, it displays a **warning** message on the Alarm screen.

See the E-Multi Mini Controller User Manual for details.

### 9.5 Servo-Motor Temperature Alarms

The motor warnings and alarm temperatures are factory settings that can only be changed by a Mold-Masters technician. The default values are:

- Warning temperature: 75°C (167°F)
- Alarm temperature: 80°C (176°F)

The controller automatically disables the motors when the alarm temperature is reached. The motor temperature can be monitored in real time on the touchscreen of the controller.

For more information about motor temperature alarms, refer to the E-Multi Mini Controller User Manual.

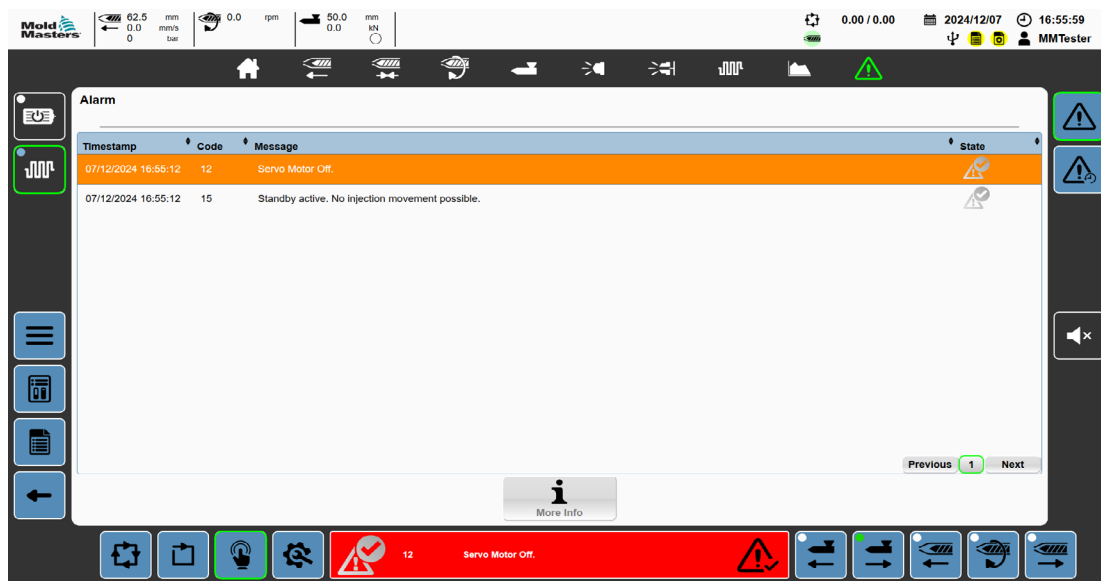

Figure 9-1 Alarm page

# Section 10 - Euromap 67

## 10.1 Scope and Application

This EUROMAP 67 recommendation defines the connection between the injection molding machine and the handling device/robot. This is intended to provide interchangeability. In addition, recommendations are given for signal voltage and current levels.

Please note that the risk assessment for the movements of the handling device/robot mostly require redundancy which is achieved by two channels on ZA3, ZC3 and ZA4, ZC4 on the injection molding machine. EUROMAP 12 will therefore only be applied for replacement purposes of existing equipment.

## 10.2 Description

The signals in both the injection molding machine and the handling device/robot are given by contacts; e.g., contacts of relays or switches and semiconductor. The contact making is either potential-free or related to a reference potential supplied to a contact of the plug mounted on the injection molding machine or the handling device/robot. All signals which are not optional shall be supported by all injection molding machines and handling devices / robots.

## 10.3 Plugs and Socket Outlets

The connection between the injection molding machine and the handling device/robot is achieved by the plugs specified in the following. For the injection molding machine and the handling device/robot, the plug contacts should be capable of taking a minimum of 250 V and 10 A.

Table 10-1 Plugs on the Injection Molding Machine		
Signals from the Injection Molding Machine to the Handling Device/Robot		
Contact No. (Male)	Signal Designation	Description
ZA1 ZC1	Emergency stop of machine channel 1	The switch contact must be open when the injection molding machine emergency stop device is being actuated. Opening the switch contact causes emergency stop of the handling device/robot.
ZA2 ZC2	Emergency stop of machine channel 2	The switch contact must be open when the injection molding machine emergency stop device is being actuated. Opening the switch contact causes emergency stop of the handling device/robot.
ZA3 ZC3	Safety devices of machine channel 1	The switch contact is closed when safety devices (e.g. safety guards, footboard safety, etc.) on the injection molding machine are operative so that dangerous movements of the device/robot are possible. The signal is active in operation mode. The signal must be the result of limit switch contact series of mold area safety devices according to EN 201.

>>

Signals from the Injection Molding Machine to the Handling Device / Robot		
Contact No. (Male)	Signal Designation	Description
ZA4 ZC4	Safety devices of machinechannel 2	The switch contact is closed when safety devices (e.g. safety guards, footboard safety, etc.) on the injection molding machine are operative so that dangerous movements of the handling device/robot are possible. The signal is active in any operation mode. The signal must be the result of limit switch contact series of mold area safety devices according to EN 201.
ZA5	Reject	HIGH signal when the molding is a reject. HIGH signal when the mold is open and must remain HIGH at least until "Enable mold closure" . Optional. See contact No A6. It is recommended to have HIGH signal already when the mold opening starts.
ZA6	Mold closed	HIGH signal when the mold closing is completed. Note: The signal "Enable mold closure" is then no longer required. See contact No A6.
ZA7	Mold open position	HIGH signal when mold opening position is equal or more than required position. Inadvertent alteration to mold opening stroke smaller than that required for the handling device/robot to approach must be impossible. The signal must remain HIGH as long as the mold is open and must not be interrupted by a change of operation mode or safety guard opening.
ZA8 Optional	Intermediate mold opening position	HIGH signal when mold opening reaches a set position smaller than mold opening position. See table 1: injection molding machine signals contact No ZA7. The signal remains HIGH to the end of mold opening position. Two sequences are possible with this signal: a) Mold opening stops on intermediate position and gives start signal to handling device/robot. Mold opening restarts with the signal "Enable full mold opening". See contact No A7. b) Mold opening does not stop on intermediate position, however gives the signal to handling device/robot. At this sequence the signals " Enable full mold opening". See connection A7 and "Mold area free" (See A3/C3) are not in use. LOW signal when intermediate mold opening position is not in use.
ZA9	Supply from handling device / robot	24 V DC (Reference potential)
ZB2	Enable operation with handling device/robot (Automatic)	HIGH signal when the injection molding machine is able to be operated with handling device/robot. This signal shall not be used to start the handling device/robot. If the signal turns LOW during the operation mode of the handling device/robot "operation with injection molding machine", it is recommended that the handling device/robot continues its automatic cycle until the end position.

&gt;&gt;

Signals from the Injection Molding Machine to the Handling Device / Robot		
Contact No. (Male)	Signal Designation	Description
ZB3	Ejector back position	HIGH signal when the ejector has been finally (e.g. after the number of its set cycles) retracted regardless of the moving platen position. The signal is the acknowledgement for the "Enable ejector retraction" signal (See contact No B3), when the ejector sequence is selected. It is recommended to have HIGH signal when the ejector sequence is not in use.
ZB4	Ejector forward position	HIGH signal when the ejector has been advanced. The signal is the acknowledgement signal for the "Enable ejector advance." See contact No B4. It is recommended to have HIGH signal when the ejector sequence is not in use.
ZB5 Optional	Core pullers 1 in position 1 (Core pullers 1 free for handling device/ robot to approach)	HIGH signal when the core pullers 1 are in position 1. See contact No B5. It is recommended to have LOW signal when the core puller sequence is not in use.
ZB6 Optional	Core pullers 1 in position 2 (Core pullers 1 in position to remove molding)	HIGH signal when the core pullers 1 are in position 2. See contact No B6. It is recommended to have LOW signal when the core puller sequence is not in use.
ZB7 Optional	Core pullers 2 in position 1 (Core pullers 2 free for handling device/ robot to approach)	HIGH signal when the core pullers 2 are in position 1. See contact No B7). It is recommended to have LOW signal when the core puller sequence is not in use.
ZB8 Optional	(Core pullers 2 in position to remove molding)	HIGH signal when the core pullers 2 are in position 2. See contact No B8. It is recommended to have LOW signal when the core puller sequence is not in use.
ZC5		Reserved for future use of EUROMAP.
ZC6		Reserved for future use of EUROMAP.
ZC7		Reserved for future use of EUROMAP.
ZC8		Not fixed by EUROMAP, manufacturer dependent.
ZC9	Supply from handling device / robot	0 V (Reference potential)

&gt;&gt;

Table 10-2 Plugs on the Injection Molding Machine Continued		
Signals from the Handling Device/robot to the Injection Molding Machine		
Contact No. (Female)	Signal Designation	Description
A1 C1	Emergency stop of handling device/robot Channel 1	The switch contact must be open when the handling device/robot emergency stop is being actuated. The switch contact opening causes emergency stop of the injection molding machine. The switch contact must be operative if the handling device/robot is switched off. It is recommended that the switch contact is operative when the handling device/robot is unselected.
A2 C2	Emergency stop of handling device/robot Channel 2	The switch contact must be open when the handling device/robot emergency stop is being actuated. The switch contact opening causes emergency stop of the injection molding machine. The switch contact must be operative if the handling device/robot is switched off. It is recommended that the switch contact is operative when the handling device/robot is unselected.
A3 C3	Mold area free	The switch contact is closed when the handling device/robot is outside the mold area and does not interfere with mold opening and closing movements. The switch contact must be opened when the handling device/robot leaves its start position. If the switch contact is open neither opening nor closing of the mold may occur. However the injection molding machine may ignore this signal when mold opening is carried out after e.g. an intermediate stop (See contact No ZA8), if the optional sequence is selected on the injection molding machine. The signal must have the described effect even when the handling device/robot is switched off. It is recommended to close the switch contact when the handling device/robot is unselected.
A4 C4		Reserved for future use by EUROMAP.
A5		Not fixed by EUROMAP, manufacturer dependent.
A6	Enable mold closure	HIGH signal when the handling device/robot is retracted enough for start of mold closure. The signal must remain HIGH at least until "Mold closed" (See contact No ZA6) is available. If the signal is LOW as a result of a fault, mold closing must be interrupted. The signal "Enable mold closure" must not be a logical "or" with either other signals, e.g. "Close safety guard" or a push button in any operation mode. The signal must be HIGH if the handling device/robot is switched off. It is recommended to have HIGH signal when the handling device/robot is unselected.
A7 Optional	Enable full mold opening	HIGH signal when the handling device/robot has taken the part and allows to continue mold opening. The signal must remain HIGH until "Mold open" signal is given by the injection molding machine. See contact No ZA7.

>>

Signals from the Handling Device/robot to the Injection Molding Machine		
Contact No. (Female)	Signal Designation	Description
A8		Reserved for future use by EUROMAP
A9	Supply from injection molding machine	24V DC / 2A (Reference potential)
B2	Handling device/ robot operation mode (operation with handling device / robot)	LOW signal when the handling device/robot mode switch is "Operation with injection molding machine". HIGH signal when the handling device/robot mode switch is "No operation with injection molding machine". HIGH signal when the handling device/robot is switched off.
B3	Enable ejector back	HIGH signal when the handling device/robot enables the movement for ejector back. The signal must remain HIGH at least until "Ejector back" signal is given by injection molding machine See contact No ZB3.
B4	Enable ejector forward	HIGH signal when the handling device/robot enables the movement for ejector forward. The signal must remain HIGH at least until "Ejector forward" signal is given by the injection molding machine. See contact No ZB4.
B5 Optional	Enable movement of core pullers 1 to position 1 (Enable movement for handling device/robot to approach freely)	HIGH signal when the handling device/robot is in position to enable the movement of the core pullers 1 to position 1. It is recommended that the signal remains HIGH at least until "Core pullers 1 in position 1" signal is given by injection molding machine (see contact No ZB5). The signal shall remain at least until position 2 has been left. See contact No ZB6.
B6 Optional	Enable movement of core pullers 1 to position 2 (Enable core pullers 1 to remove the molding)	HIGH signal when the handling device/robot is in position to enable the movement of the core pullers 1 to position 2. It is recommended that the signal remains HIGH at least until "Core pullers 1 in position 2" signal is given by injection molding machine. See contact No ZB6. The signal shall remain at least until position 1 has been left. (See contact No ZB5).
B7 Optional	Enable movement of core pullers 2 to position 1 (Enable movement for handling device/robot to approach freely)	HIGH signal when the handling device/robot is in position to enable the movement of the core pullers 2 to position 1. It is recommended that the signal remains HIGH at least until "Core pullers 2 in position 1" signal is given by injection molding machine. See contact No ZB7. The signal shall remain at least until position 2 has been left. See contact No ZB8.
B8 Optiona	Enable movement of core pullers 2 to position 2 (Enable core pullers 2 to remove the molding)	HIGH signal when the handling device/robot is in position to enable the movement of the core pullers 2 to position 2. It is recommended that the signal remains HIGH at least until "Core pullers 2 in position 2" signal is given by injection molding machine. See contact No ZB8. The signal shall remain at least until position 1 has been left. See contact No ZB7

&gt;&gt;

Signals from the Handling Device/robot to the Injection Molding Machine		
Contact No. (Female)	Signal Designation	Description
C5		Not fixed by EUROMAP, manufacturer dependent.
C6		Reserved for future use by EUROMAP.
C7		Reserved for future use by EUROMAP.
C8		Not fixed by EUROMAP, manufacturer dependent.
C9	Supply from injection molding machine	0V (Reference potential)

# Section 11 - Cooling Water

## 11.1 Detailed Water-Quality Specifications

Detailed Water-Quality Specifications			
Constituents	Units	Closed Loop	Tower Water
pH	pH Units	7.2 - 8.5	7.2 - 8.5
"M" Alkalinity	ppm	N/A	< 500
"P" Alkalinity	ppm	0	0
Total Hardness (as CaCO <sub>3</sub> )	ppm	< 10	60 - 800
Calcium Hardness (as CaCO <sub>3</sub> )	ppm	< 10	60 - 800
Conductivity	µmhos/cm	< 3000	1000 - 2000
Ryznar Stability Index	RSI	5.0 - 6.0	5.0 - 6.0
Cations			
Aluminum (as Al)	ppm	< 0.1	< 0.1
Copper (as Cu)	ppm	< 0.05	< 0.1
Manganese (as Mn)	ppm	< 0.05	< 0.05
Total Iron (as Fe)	ppm	<0.5	< 0.1
Anions			
Free Chlorine (as Cl <sub>2</sub> )	ppm	0	< 1.0
Chloride (as Cl)	ppm	< 400	< 400
Sulfate (as SO <sub>2</sub> )	ppm	< 300	< 300
Silica (as SiO <sub>2</sub> )	ppm	< 150	< 150
Microbiological Activity			
Sulfate Reducing Bacteria	Col./ml	< 1	< 1
Total Aerobic Bacteria	Col./ml	< 10 000	<10 000
Solids			
Suspended Solids	ppm	< 10	< 10
Solid Size	µm	< 5	< 5
Maximum Corrosion Rate (of 90 Day Test Specimens, If Used)			
Aluminum	mils Per Year	< 0.25	< 0.5
Copper	mils Per Year	< 0.25	< 0.2
Mild Steel	mils Per Year	< 1.0	< 2.0
Zinc	mils Per Year	< 2.0	< 2.0

## 11.2 Cooling Line Contamination

The condition of the cooling lines can be seen by inspection. Figure 11-1 Comparison of clean and contaminated cooling lines shows three examples of clear blue tubing. Calcium deposits make the tubing appear green (or pink in the case of clear red tubing) and opaque.

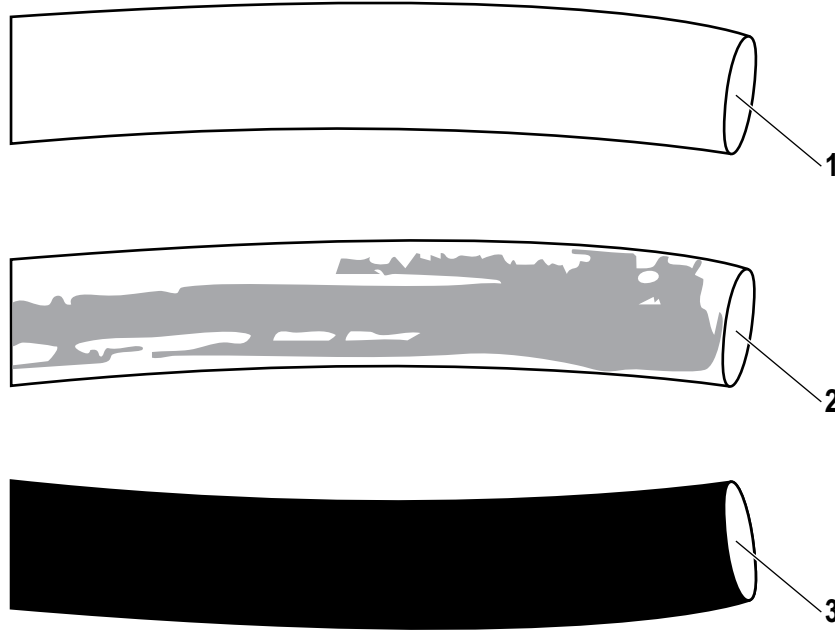

Figure 11-1 Comparison of clean and contaminated cooling lines

Table 11-1 Cooling Line Contaminations	
Position	Part
1	New water tube
2	Used tubing in good condition (no obstructing deposits)
3	Heavy sediment deposits

# Index

## Symbols

>>...1-1

## A

actuator  
   linear carriage  
     calibrating...8-15  
 adapter plate  
   installing...8-10  
   removing...8-10  
   replacing...8-10–8-11  
 alarm  
   control system...d  
   servo-motor temperature...9-3  
   transducer output...9-3  
 alarms...9-1

## B

ball check seat  
   removing...8-31  
 barrel  
   assembling...8-34  
   disassembling...8-28  
   installing...8-34  
   preparing to remove...8-28  
   removing...8-32

## C

cable  
   servo...6-1  
 controller  
   connecting to  
     EMM...6-1  
     robot...6-2  
   installing...5-9  
   repairing...8-35  
   servicing...8-35  
   shutdown...7-2  
   startup...7-2  
   weight...3-16  
 cooling line  
   contamination...11-2  
 cooling system limits...6-4  
 cooling water  
   purging...8-9  
   quality...6-5, 11-1  
   schematic...6-4  
   temperature...6-5  
 corrosion...6-5  
 coupled screw...8-24

crate  
   contents...5-1–5-2  
   unpacking...5-2

## D

disposal...3-13  
 document  
   conventions...1-1  
   release details...1-1

## E

E67 robot...6-2  
 E-Multi Mini  
   components...4-1–4-2  
   dimensions...3-16  
   horizontal lifting...5-7  
   lifting...5-4  
   operating...7-1  
   vertical lifting...5-6  
   weight...3-16  
 Euromap 67...10-1

## F

feed  
   screw  
     removing...8-23  
 feed assembly  
   removing...8-20  
   replacing...8-20  
 feed block  
   installing...8-21  
 feed screw  
   cleaning...8-25  
   installing...8-25  
   preparing for removal...8-22  
   removing...8-23  
 feed tube  
   removing...8-19  
 flow rate  
   water...6-5

## G

grease. See lubrication  
 grease nipple. See lubrication nipple  
 guards  
   safety...3-16

## H

heater bands  
   replacing...8-19

- heating
  - turning off...7-2
- hopper
  - removing...8-19
- humidity...5-10

**I**

- injection axis
  - referencing...8-18
- injection nozzle
  - replacing...8-14
- installation
  - controller...5-9

**L**

- lift
  - connections...5-5
  - procedures...5-6
- lifting
  - general...5-4
  - horizontal...5-7
  - procedures...5-6
  - vertical...5-6
- limits
  - cooling system...6-4
- linear carriage actuator
  - calibrating...8-15
- linear vibrator...9-2
- lubrication
  - ball screw...8-5
  - guidelines...8-3
  - linear rails...8-7
  - types of...8-3

**M**

- main power switch
  - controller...7-1
- maintenance
  - preventive...8-1
  - schedule...8-1

**N**

- nozzle
  - injection
    - replacing...8-14
- nozzle protrusion...8-11

**P**

- plastic purging...8-8
- pneumatic connections...6-2
- power switch
  - main
    - controller...7-1
- preventive maintenance...8-1

**R**

- returning goods...1-1

- robots...6-2

**S**

- safety...3-1
- safety guards...3-16
- safety symbols...3-7
- screw
  - coupled...8-24
  - feed
    - cleaning...8-25
    - removing...8-23–8-24
  - uncoupled...8-24
- servo cables
  - routing and connecting...6-1
- servo-motor
  - temperature alarms...9-3
- setup...6-1
- shutdown
  - controller...7-2
- SPI robots...6-2
- startup
  - controller...7-2
- support...2-1

**T**

- temperature
  - operating...5-10, 6-5
- temperature alarms...9-3
- test
  - heater continuity...9-1
  - linear vibrator...9-2
  - thermocouple electrical...9-1
- tests...9-1
- torques
  - other...8-2
  - screw...8-1

**U**

- unpacking...5-2

**V**

- vibrator...9-2

**W**

- warranty...1-1
- water quality...11-1
- weights...3-16
- wiring check...3-9

# Tables

Table 1-1 Document Release Details .....	1-1
Table 1-2 Units of Measure and Conversion Factors .....	1-2
Table 3-1 Safety Hazards .....	3-2
Table 3-2 Safety Symbols .....	3-7
Table 3-3 Energy Forms, Energy Sources and General Lockout Guidelines .....	3-12
Table 3-4 Injection Unit Safety Hazards .....	3-14
Table 3-5 Guards .....	3-16
Table 3-6 Shipping Dimensions and Weights .....	3-16
Table 4-1 Injection Unit Components (back).....	4-1
Table 4-2 Injection Unit Components (front).....	4-2
Table 6-1 Cooling System Limits .....	6-4
Table 6-2 Basic Water-Quality Specifications .....	6-5
Table 8-1 Preventive Maintenance Schedule .....	8-1
Table 8-2 Screw Torques .....	8-1
Table 8-3 Screw Torques Continued.....	8-2
Table 8-4 Nozzle Tip Torque .....	8-2
Table 8-5 Lubrication Guidelines .....	8-3
Table 8-6 Adapter Plate Components .....	8-10
Table 8-7 Nozzle Protrusion .....	8-12
Table 8-8 Adapter Plate Components.....	8-12
Table 10-1 Plugs on the Injection Molding Machine .....	10-1
Table 10-2 Plugs on the Injection Molding Machine Continued.....	10-4
Table 11-1 Cooling Line Contaminations .....	11-2

# Figures

Figure 3-1 Hazard areas of an injection molding machine (front view) .....	3-1
Figure 3-2 Hazard areas of an injection molding machine (top view).....	3-2
Figure 3-4 Injection unit safety hazards.....	3-14
Figure 3-5 Layout of top cover guard .....	3-16
Figure 4-1 Injection unit components (back) .....	4-1
Figure 4-2 Injection unit components (front).....	4-2
Figure 5-1 Opening the crate.....	5-2
Figure 5-2 Lifting the E-multi Mini out of the crate.....	5-3
Figure 5-3 Vertical lift connections.....	5-5
Figure 5-4 Horizontal lift connections .....	5-5
Figure 5-5 Vertical lifting .....	5-6
Figure 5-6 Horizontal lifting.....	5-7
Figure 6-1 Pneumatic connections .....	6-3
Figure 6-2 Cooling water supply and return .....	6-3
Figure 6-3 Cooling water schematic .....	6-4
Figure 7-1 Main power switch.....	7-1
Figure 8-1 Removing the port plugs .....	8-5
Figure 8-2 Lubricating the injection ball screw .....	8-6
Figure 8-3 Lubricating the linear guides .....	8-7
Figure 8-4 Removing the adapter plate .....	8-10
Figure 8-5 Nozzle .....	8-11
Figure 8-6 Nozzle protrusion .....	8-11
Figure 8-7 Removing the adapter plate .....	8-12
Figure 8-8 Main carriage page .....	8-16
Figure 8-11 Removing the feed assembly .....	8-20
Figure 8-12 Removing the top cover .....	8-21
Figure 8-13 Uncoupling page .....	8-22
Figure 8-14 Coupled screw (left) and uncoupled screw (right).....	8-23
Figure 9-1 Alarm page .....	9-2
Figure 11-1 Comparison of clean and contaminated cooling lines .....	11-2



Scan the QR code for our global contacts: