

E-Multi[®] mini

Controller User Manual

version 1



Contents

Section 1 - Introduction	1-1
1.1 Intended Use	1-1
1.2 User-Manual Release Details	1-1
1.3 Warranty	1-1
1.4 Returned Goods Policy.....	1-1
1.5 Movement or Resale of Mold-Masters Products or Systems	1-2
1.6 Copyright	1-2
1.7 Units of Measure and Conversion Factors	1-2
 Section 2 - Global Support	 2-1
2.1 Worldwide Locations	2-1
 Section 3 - Safety.....	 3-1
3.1 Introduction.....	3-1
3.2 Safety Hazards	3-2
3.3 Operational Hazards.....	3-6
3.4 General Safety Symbols.....	3-8
3.5 Wiring Check	3-9
3.6 Lockout Safety	3-10
3.6.1 Electrical Lockout.....	3-11
3.6.2 Energy Forms and Lockout Guidelines.....	3-12
3.7 Ground Connections.....	3-13
3.8 Disposal.....	3-14
3.9 Controller Safety Hazards	3-15
3.9.1 Operational Environment.....	3-15
3.9.2 Cabinet Tip (Push) Forces	3-16
3.10 Unpacking the controller.....	3-17
3.11 Lifting the controller	3-17
3.11.1 Preparation	3-17
 Section 4 - Hardware Overview.....	 4-1
4.1 Controller Front.....	4-1
4.2 Controller Back (Connections).....	4-2
 Section 5 - Installation	 5-1
5.1 Introduction	5-1
5.2 Connecting the controller to the E-Multi Mini.....	5-2
5.3 Connecting a robot to the controller	5-3
5.4 Connecting the controller to the power supply	5-4
5.5 Connecting the controller to the molding machine	5-5
5.6 Connecting a diagnostic computer (optional)	5-6
 Section 6 - Hardware Operation	 6-1
6.1 Introduction.....	6-1

6.2 Powering on.....	6-2
6.3 Powering off.....	6-2
6.3.1 Shut down the heating.....	6-2
6.3.2 Shut down the controller.....	6-2

Section 7 - Touchscreen7-1

7.1 Introduction.....	7-1
-----------------------	-----

Section 8 - Software Overview8-1

8.1 Home Screen	8-1
8.1.1 Header	8-1
8.1.2 Navigation Bar	8-3
8.1.3 Left Panel.....	8-5
8.1.4 Contextual (Right) Panel.....	8-7
8.1.5 Footer	8-8
8.2 Screen Directory.....	8-13
8.2.1 E-Multi Mini Directory.....	8-13
8.2.2 Machine Directory.....	8-14
8.2.3 Data Directory.....	8-16
8.3 Overview	8-17
8.4 Injection	8-18
8.4.1 Calibration.....	8-22
8.5 Hold	8-24
8.6 Plasticizing	8-27
8.7 Auto Purge.....	8-31
8.8 Carriage (DC Motor).....	8-33
8.9 Pneumatic Controls	8-36
8.9.1 Valve Gates	8-36
8.10 Barrel Heats.....	8-39
8.10.1 Barrel Heats.....	8-39
8.10.2 Barrel Heats Configuration	8-42
8.11 Incremental Startup	8-48
8.12 RJG Interface	8-52
8.13 Sequence	8-54
8.13.1 Sequence Viewer Screen	8-54
8.13.2 Sequence Editor Screen.....	8-56
8.14 Trace.....	8-61
8.14.1 Graph Screen	8-61
8.14.2 Configuration Screen	8-63
8.15 Alarms.....	8-66
8.15.1 Alarm History	8-67
8.16 Temperature	8-69
8.16.1 Temperature Screen	8-69
8.16.2 Temperature Monitoring.....	8-70
8.17 I/O.....	8-71
8.17.1 Digital Inputs	8-71
8.17.2 Digital Outputs	8-73
8.17.3 Analog Inputs.....	8-74
8.17.4 Analog Outputs.....	8-76
8.17.5 Analog Temperature	8-77

8.18 Custom I/O	8-79
8.18.1 Custom Digital Inputs.....	8-79
8.18.2 Custom Digital Outputs.....	8-80
8.18.3 Analog Inputs	8-82
8.18.4 Analog Outputs	8-83
8.18.5 Custom Digital I/O.....	8-84
8.18.6 Custom Analog I/O.....	8-85
8.18.7 Custom Process Variables.....	8-86
8.19 Axis Information	8-87
8.19.1 Temperature Tab.....	8-87
8.19.2 Brake Tab.....	8-88
8.19.3 Drive Tab.....	8-89
8.19.4 Power Supply	8-90
8.20 HMI Configuration.....	8-91
8.21 Euromap 67 (E67)	8-94
8.21.1 E67 Output Configuration Tab	8-96
8.21.2 E67 Input Configuration	8-97
8.21.3 E67 Settings Tab.....	8-98
8.22 Files	8-100
8.22.1 Recipe Data	8-100
8.22.2 Fixed Data	8-102
8.22.3 User Data.....	8-104
8.23 Documents (PDFs).....	8-105
8.23.1 Documents (PDFs).....	8-105
8.23.2 Web Screen	8-106
8.24 Production	8-109
8.24.1 Production Screen	8-109
8.25 Wait Timers.....	8-111
8.26 Schedule.....	8-112
8.27 Change Log	8-115
8.28 Log Book	8-116
8.29 Machine Information	8-118
8.30 Data Logger	8-119
8.30.1 Data Logger Screen.....	8-119
8.30.2 Data Logger Configuration.....	8-120
8.31 Cycle Information.....	8-123
8.32 Material Data	8-125
8.33 Timers.....	8-127
8.34 Counters	8-129
8.35 Interface Overview.....	8-131
8.36 Key Switch.....	8-134

Section 9 - Software Operation9-1

9.1 Logging in	9-1
9.2 Managing users	9-2
9.2.1 Navigating to the User Management screen	9-2
9.2.2 Creating a user	9-3
9.2.3 Deleting a user.....	9-4
9.2.4 Exporting user management data.....	9-4
9.2.5 Importing user management data.....	9-5
9.3 Managing recipe and fixed data	9-5
9.3.1 Creating a recipe file.....	9-5

9.3.2 Saving recipe data	9-6
9.3.3 Deleting a recipe file	9-6
9.3.4 Creating a fixed data file	9-6
9.3.5 Saving fixed data	9-6
9.3.6 Deleting a fixed data file	9-7
9.4 Configuring the controller	9-7
9.4.1 Graphical representation of the axis stroke limits	9-7
9.4.2 Using the Conditions detailed-dialog box	9-9
9.4.3 Using the Motor-Selection dialog box	9-12
9.4.4 Configuring the I/O.....	9-14
9.5 Using the controller.....	9-18
9.5.1 Powering the motors.....	9-18
9.5.2 Turning off power to the motors	9-18
9.5.3 Putting the controller into calibration mode.....	9-18
9.5.4 Putting the controller into setup mode	9-18
9.5.5 Putting the controller into manual mode	9-19
9.5.6 Putting the controller into auto-mode.....	9-20

Section 10 - Maintenance..... 10-1

10.1 Cleaning the touchscreen.....	10-1
10.2 Preventive Maintenance	10-1
10.3 Putting the carriage in the service position.....	10-2
10.4 Calibrating the carriage home position	10-3
10.5 Referencing the injection axis.....	10-4
10.6 Servicing and repairing the controller	10-5
10.6.1 Replacing parts	10-5
10.6.2 Inspecting and cleaning	10-5
10.7 Updating the software.....	10-6
10.7.1 Saving mold data.....	10-6
10.7.2 Saving fixed (machine) data	10-7
10.7.3 Backing up user data	10-9
10.7.4 Installing new software	10-12

Section 11 - Troubleshooting11-1

11.1 Doing an electrical check of a thermocouple	11-1
11.2 Checking the heater continuity	11-1
11.3 Checking the heater continuity	11-1
11.4 Checking the vibrator valve	11-1
11.5 Checking the motor temperature	11-2
11.6 Troubleshooting the control system	11-2

Index I

Section 1 - Introduction

The purpose of this manual is to assist users in the integration, operation and maintenance of the E-Multi Mini controller. This manual is designed to cover most system configurations. If you need additional information specific to your system please contact your representative or a Mold-Masters office whose location can be found in the “Global Support” section.

1.1 Intended Use

The E-Multi Mini controller is an electrical switching device designed for use with the E-Multi Mini Auxiliary Injection Unit (AIU). It is designed to be safe during normal operation. Any other uses would fall outside the engineered intent of this machine which may be a safety hazard and would void any and all warranties.

This manual is written for use by skilled persons who are familiar with injection molding machinery and their terminology. Operators should be familiar with plastic injection molding machines and the controls of such equipment. Maintenance persons should have sufficient understanding of electrical safety to appreciate the dangers of 3-phase supplies. They should know how to take appropriate measures to avoid any danger from electrical supplies.

1.2 User-Manual Release Details

Table 1-1 User-Manual Release Details		
Document Number	Release Date	Version
UM--EMMC--ENG--01	February 2026	01

1.3 Warranty

For current warranty information please see the documents in the warranty section of the Mold-Masters website www.moldmasters.com or contact your Mold-Masters representative.

1.4 Returned Goods Policy

Please do not return any parts to Mold-Masters without pre-authorization and a return authorization number supplied by Mold-Masters.

Our policy is one of continuous improvement and we reserve the right to alter product specifications at any time without giving notice.

1.5 Movement or Resale of Mold-Masters Products or Systems

This documentation is intended for use in the country of destination for which the product or system was purchased.

Mold-Masters takes no responsibility for documentation of products or systems if they are relocated or resold outside the intended country of destination, as stated on the accompanying invoice and/or waybill.

1.6 Copyright

© 2026 Mold-Masters (2007) Limited. All Rights Reserved. Mold-Masters® and the Mold-Masters logo are trademarks of Mold-Masters.

1.7 Units of Measure and Conversion Factors



NOTE

The dimensions given in this manual are from original manufacturing drawings.

All values in this manual are in S.I. units or subdivisions of these units. Imperial units are given in parentheses immediately after the S.I. units.

Table 1-2 Units of Measure and Conversion Factors		
Abbreviation	Unit	Conversion Value
bar	Bar	14.5 psi
in.	Inch	25.4 mm
kg	Kilogram	2.205 lb
kPa	Kilopascal	0.145 psi
gal	Gallon	3.785 l
lb	Pound	0.4536 kg
lbf	Pound force	4.448 N
lbf.in.	Pound force inch	0.113 Nm
l	Litre	0.264 gallon
min	Minute	
mm	Millimeter	0.03937 in.
mΩ	Milli Ohm	
N	Newton	0.2248 lbf
Nm	Newton Meter	8.851 lbf.in.
psi	Pound per square inch	0.069 bar
psi	Pound per square inch	6.895 kPa
rpm	Revolutions per minute	
s	Second	
°	Degree	
°C	Degree Celsius	0.556 (°F -32)
°F	Degree Fahrenheit	1.8 °C +32

Section 2 - Global Support

2.1 Worldwide Locations

To find your nearest Mold-Masters office for sales or service support, please visit www.moldmasters.com/location-map or scan this QR code:



Section 3 - Safety

3.1 Introduction

Please be aware that the safety information provided by Mold-Masters does not absolve the integrator and employer from understanding and following international and local standards for safety of machinery. It is the responsibility of the end integrator to integrate the final system, provide necessary e-stop connections, safety interlocks and guarding, to choose the appropriate electrical cable for the region of use and to ensure compliance with all relevant standards.

It is the responsibility of the employer to:

- Properly train and instruct its personnel in the safe operation of equipment, including the use of all the safety devices.
- Provide its personnel with all necessary protective clothing, including such items as a face shield and heat resistant gloves.
- Ensure the original and continuing competence of personnel caring for, setting up, inspecting and maintaining injection molding equipment.
- Establish and follow a program of periodic and regular inspections of injection molding equipment to ensure it is in safe operating condition and proper adjustment.
- Ensure that no modifications, repairs, or rebuild of portions are made to the equipment that reduces the level of safety existing at time of manufacture or remanufacture.

3.2 Safety Hazards



WARNING
 Also refer to all machine manuals and local regulations and codes for safety information.

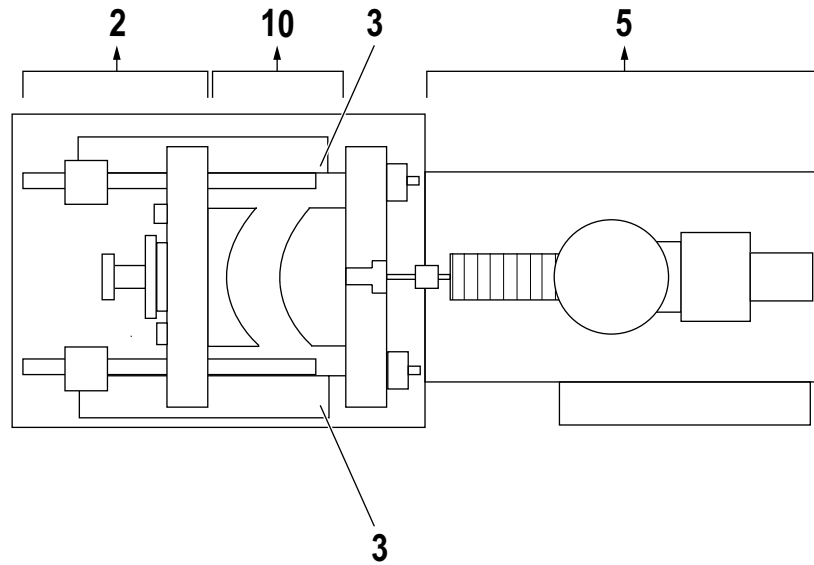

Figure 3-1 Injection molding machine hazard areas (Top view with guards removed)

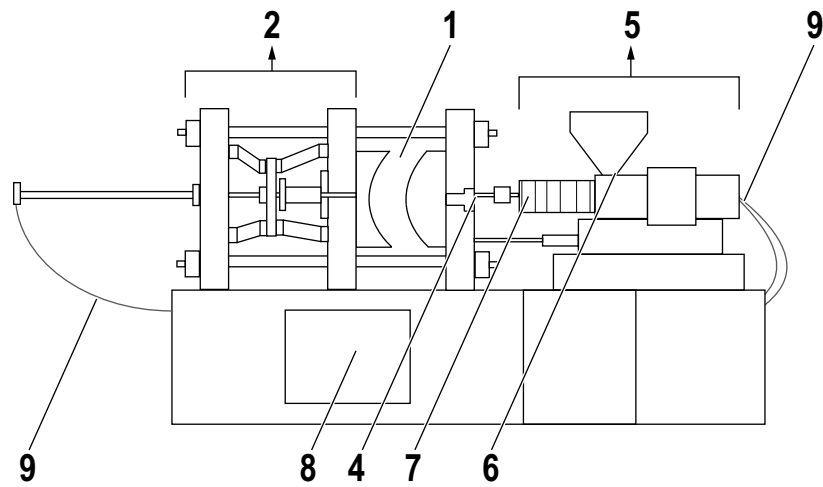

Figure 3-2 Injection molding machine hazard areas (Front view with guards removed)

Table 3-1 Safety Hazards		
Ref. no	Hazard Area	Potential Hazards
1	<p>Mold Area Area between the platens.</p>	<p>Mechanical Hazards Crushing and/or shearing and/or impact hazards caused by:</p> <ul style="list-style-type: none"> • Movement of the platen. • Movements of the injection barrel(s) into the mold area. • Movements of cores and ejectors and their drive mechanisms. • Tie bar motion. <p>Thermal Hazards Burns and/or scalds due to operating temperature of:</p> <ul style="list-style-type: none"> • The mold heating elements. • Plasticized material released from / through the mold.
2	<p>Clamping Mechanism Area</p>	<p>Mechanical Hazards Crushing and/or shearing and/or impact hazards caused by:</p> <ul style="list-style-type: none"> • Movement of the platen. • Movement of the drive mechanism of the platen. • Movement of the core and ejector drive mechanism.
3	<p>Movement of Drive Mechanisms Outside the Mold Area and Outside the Clamping Mechanism Area.</p>	<p>Mechanical Hazards Mechanical hazards of crushing, shearing and/or impact caused by the movements of:</p> <ul style="list-style-type: none"> • Core and ejector drive mechanisms.
4	<p>Nozzle Area The nozzle area is the area between the barrel and the sprue bushing.</p>	<p>Mechanical Hazards Crushing, shearing hazards, and/or impact hazards caused by:</p> <ul style="list-style-type: none"> • Forward movement of the plasticizing and/or injection unit including nozzle. • Movements of parts of-the power operated nozzle shutoff and their drives. • Over pressurization in the nozzle. <p>Thermal Hazards Burns and/or scalds due to operating temperature of:</p> <ul style="list-style-type: none"> • The nozzle. • Material discharging from the nozzle.

Ref. no	Hazard Area	Potential Hazards
5	Plasticizing and / or Injection Unit Area Area from the adapter / barrel head / end cap to the extruder motor above the sled including the carriage cylinders.	<p>Mechanical Hazards Crushing, shearing and/or drawn-into hazards caused by:</p> <ul style="list-style-type: none"> • Unintentional gravity movements e.g. for machines with plasticizing and/or injection unit positioned above the mold area. • The movements of the screw and/or the injection plunger in the cylinder accessible through the feed opening. • Movement of the carriage unit. <p>Thermal Hazards Burns and/or scalds due to operating temperature of:</p> <ul style="list-style-type: none"> • The plasticizing and/or injection unit. • The heating elements e.g. heaterbands. • The material and/or vapors discharging from the vent opening, feed throat or hopper. <p>Mechanical and/or Thermal Hazard</p> <ul style="list-style-type: none"> • Hazards due to reduction in mechanical strength of the plasticizing and/or injection cylinder due to overheating.
6	Feed Opening	<p>Pinching and crushing between injection screw movement and housing.</p>
7	Area of the Heater Bands of the Plasticizing and/or Injection Cylinders	<p>Burns and/or scalds due to operating temperature of:</p> <ul style="list-style-type: none"> • The plasticizing and/or injection unit. • The heating elements e.g. heater bands. • The material and/or vapors discharging from the vent opening, feed throat or hopper.
8	Parts Discharge Area	<p>Mechanical Hazards Accessible Through the Discharge Area Crushing, shearing and/or impact hazards caused by: Closing movement of the platen.</p> <ul style="list-style-type: none"> • Movements of cores and ejectors and their drive mechanisms. <p>Thermal Hazards Accessible through the discharge area Burns and or scalds due to operating temperature of:</p> <ul style="list-style-type: none"> • The mold. • Heating elements of the mold. • Material released from / trough the mold

Ref. no	Hazard Area	Potential Hazards
9	Hoses	Whipping action caused by hose assembly failure. <ul style="list-style-type: none"> • Possible release of fluid under pressure that can cause injury. • Thermal hazards associated with hot fluid
10	Area Inside the Guards and Outside the Mold Area	Crushing and/or shearing and/or impact hazards caused by: Movement of the platen. <ul style="list-style-type: none"> • Movement of the drive mechanism of the platen. • Movement of the core and ejector drive mechanism. • Clamp opening movement.
-	Electrical Hazards	<ul style="list-style-type: none"> • Electrical or electromagnetic disturbance generated by the motor control unit. • Electrical or electromagnetic disturbance that can cause failures in the machine control systems and adjacent machine controls. • Electrical or electromagnetic disturbance generated by the motor control unit
-	Hydraulic Accumulators	High pressure discharge
-	Power Operated Gate	Crush or impact hazards caused by the movement of the power operated gate
-	Vapors and Gases	Certain processing conditions and/or resins can cause hazardous fumes or vapors

3.3 Operational Hazards











WARNINGS







- Refer to all machine manuals and local regulations and codes for safety information.
- The equipment supplied is subjected to high injection pressures and high temperatures. Ensure that extreme caution is observed in the operation and maintenance of the injection molding machines.
- Only fully trained personnel should operate or maintain equipment.
- Do not operate the equipment with unconfined long hair, loose clothing or jewelry, including name badges, neckties, etc. These may get caught in the equipment and can cause death or serious injury.
- Never disable or bypass a safety device.
- Ensure that the protective guards are placed around the nozzle to prevent the material from splashing or drooling.
- A burn hazard exists from material during routine purging. Wear heat-resistant personal protective equipment (PPE) to prevent burns from contact with hot surfaces or splatter of hot material and gases.
- Material purged from machine may be extremely hot. Ensure protective guards are in place around the nozzle to prevent material from splashing. Use proper personal protective equipment.
- All operators should wear personal protective equipment, such as face shields and use heat resistant gloves when working around the feed inlet, purging the machine or cleaning the gates of the mold.
- Remove purged material from the machine immediately.
- Decomposing or burning material could result in noxious gases being emitted from the purged material, feed inlet or mold.
- Ensure proper ventilation and exhaust systems are in place to help prevent inhalation of harmful gases and vapors.
- Consult manufacturer's Material Safety Data Sheets (MSDS).
- Hoses fitted to the mold will contain high or low temperature fluids or air under high pressure. The operator must shut down and lockout these systems as well as relieving any pressure before performing any work with these hoses. Regularly inspect and replace all flexible hoses and restraints.
- Water and/or hydraulics on the mold may be in close proximity to electrical connections and equipment. Water leakage may cause an electrical short circuit. Hydraulic fluid leakage may cause a fire hazard. Always keep water and/or hydraulic hoses and fittings in good condition to avoid leaks.
- Never perform any work on the mold machine unless the hydraulic pump has been stopped.
- Check frequently for possible oil leaks / water leaks. Stop the machine and make repairs.

**WARNING**

- Make sure that the cables are connected to the correct motors. Cables and motors are clearly labeled. Reversing the cables can result in unexpected and uncontrolled motion causing a safety risk or damage to the machine.
- A crushing hazard exists between the nozzle and mold melt inlet during carriage forward motion.
- A possible shearing hazard exists between the edge of the injection guard and the injection housing during injection.
- The open feed port could present a hazard to a finger or a hand inserted during operation of the machine.
- The electric servo motors could overheat presenting a hot surface which could cause burns to someone touching it.
- The barrel, barrel head, nozzle, heater bands and mold components are hot surfaces which could result in burns.
- Keep flammable liquids or dust away from the hot surfaces as they could ignite.
- Follow good housekeeping procedures and keep floors clean to prevent slips, trips and falls due to spilled material on the work floor.
- Apply engineering controls or hearing conservation programs as necessary to control noise.
- When doing any work on the machine that requires moving and lifting the machine, ensure that lifting equipment (eyebolts, fork lift truck, cranes, etc.) will have sufficient capacity to handle mold, auxiliary injection unit or Hot Runner weight.
- Connect all lifting devices and support the machine using a crane of adequate capacity before commencing work. Failure to support the machine can result in severe injury or death.
- Mold cable from the controller to the mold must be removed before servicing the mold

3.4 General Safety Symbols

Table 3-2 Typical Safety Symbols	
Symbol	General Description
	General – Warning Indicates an immediate or potentially hazardous situation, which if not avoided, could result in a serious injury or death, and/or damage to equipment.
	Warning – Barrel Cover Grounding Strap Lockout/Tagout procedures must be followed before removing the barrel cover. Barrel cover can become energized upon removal of grounding straps and contact can result in death or serious injury. Grounding straps must be reconnected before reconnecting power to machine.
	Warning – Crushing and/or Impact Points Contact with moving parts can cause serious crushing injury. Always keep guards in place.
	Warning – Crush Hazard Closing Mold
	Warning – Hazardous Voltage Contact with hazardous voltages will cause death or serious injury. Turn off power and review electrical schematics before servicing equipment. May contain more than one live circuit. Test all circuits before handling to make sure circuits have been de-energized.
	Warning – High Pressure Overheated fluids may cause severe burns. Discharge pressure before disconnecting water lines.
	Warning – High Pressure Accumulator Sudden release of high pressure gas or oil can cause death or serious injury. Discharge all gas and hydraulic pressure before disconnecting or disassembling accumulator.
	Warning – Hot Surfaces Contact with exposed hot surfaces will cause serious burn injury. Wear protective gloves when working near these areas.

Symbol	General Description
	<p>Mandatory – Lockout/tagout</p> <p>Ensure that all energies are properly locked out, and remain locked out until the service work is completed. Servicing equipment without disabling all internal and external power sources can cause death or serious injury. De-energize all internal and external power sources (electrical, hydraulic, pneumatic, kinetic, potential, and thermal).</p>
	<p>Warning – Material Splashing Hazard</p> <p>Molten material or high pressure gas can cause death or severe burns. Wear personal protective equipment while servicing the feed throat, nozzle, mold areas, and when purging the injection unit.</p>
	<p>Warning – Read Manual Before Operation</p> <p>Personnel should read and understand all instructions in the manuals before working on equipment. Only properly trained personnel should operate the equipment.</p>
	<p>Warning – Slip, Trip or Fall Hazard</p> <p>Do not climb on equipment surfaces. Serious slip, trip or fall injuries can result from personnel climbing on equipment surfaces.</p>
	<p>Caution</p> <p>Failure to follow instructions may damage equipment.</p>
	<p>Note</p> <p>Indicates additional information or used as a reminder.</p>

3.5 Wiring Check

System Mains Supply Wiring:

- Before connecting the system to a power supply, it is important to check that the wiring between the system and the power supply has been done correctly.
- Particular attention must be given to the current rating of the power supply. For example, if a controller is rated at 63 A, then the power supply must also be rated at 63 A.
- Check that the phases of power supply are wired correctly.

Controller to Mold Wiring:

- For mixed power and thermocouple connections, ensure that the power and thermocouple connections have not been wired incorrectly.

Communications Interface and Control Sequence:

- It is the customer's responsibility to verify functionality of any custom machine interface at safe speeds, prior to operating equipment in the production environment at full speed in automatic mode.
- It is the customer's responsibility to verify all required motion sequences are correct, prior to operating equipment in the production environment at full speed in automatic mode.
- Switching the machinery into Auto-mode without having verified the control interlocks and motion sequence are correct, may cause damage to machinery and/or equipment.

Failure to do wiring or connections properly will result in equipment failure.

3.6 Lockout Safety



WARNING

DO NOT enter the cabinet without first ISOLATING the supplies.

Voltage and amperage cables are connected to the controller and the mold. Electric power must be shut off and lockout/tagout procedures followed prior to installing or removing any cables.

Use lockout/tagout to prevent operation during maintenance.

All maintenance should be performed by properly trained personnel based on local laws and regulation. Electrical products may not be grounded when removed from the assembled or normal operating condition.

Ensure proper grounding of all electrical components before performing any maintenance to avoid potential risk of electrical shock.

Often power sources are inadvertently turned on or valves are opened mistakenly before maintenance work is completed, resulting in serious injuries and fatalities. Therefore, it is important to ensure that all energies are properly locked out and that they remain locked out until the work is completed.

If a lockout is not performed, uncontrolled energies could cause:

- Electrocution from contact with live circuits
- Cuts, bruises, crushing, amputations or death, resulting from entanglement with belts, chains, conveyors, rollers, shafts, impellers
- Burns from contact with hot parts, materials or equipment such as furnaces
- Fires and explosions
- Chemical exposures from gases or liquids released from pipelines

3.6.1 Electrical Lockout

Employers must provide an effective lockout/tagout program.



WARNING - READ MANUAL

Refer to all machine manuals and local regulations and codes.



NOTE

In some instances, there may be more than one power source feeding equipment and steps must be taken to ensure that all sources are effectively locked out.

1. Shut down machine using normal operational shutdown procedure and controls. This should be done by, or in consultation with the machine operator.
2. After ensuring that the machinery has been completely shut down, and all controls in the “off” position, open the main disconnect switch located in the field.
3. Using your own personal padlock, or one assigned by your supervisor, lock the disconnect switch in the off position. Do not lock only the box. Remove the key and retain. Complete a lockout tag and affix to the disconnect switch. Each person working on the equipment must follow this step. The lock of the person doing the work or in charge must be installed first, remain throughout and be removed last. Test the main disconnect switch and make sure it cannot be moved to the “on” position.
4. Try to start the machine using the normal operation controls and point of operation switches to make sure that the power has been disconnected.
5. Other sources of energy that could create a hazard while working on the equipment must also be de-energized and appropriately “locked-out”. This can include gravity, compressed air, hydraulics, steam and other pressurized or hazardous liquids and gases (see table below).
6. When the work is completed, prior to removing the last lock, make sure the operational controls are in the “off” position so that the main disconnect switching is done under “no load”. Ensure all blocks, tools and other foreign materials are removed from machine. Also ensure that all personnel that may be affected are informed that the lock(s) will be removed.
7. Remove lock and tag, and close the main disconnect switch if permission has been given.
8. When the work has not been completed on the first shift, the next operator should install a personal lock and tag before the first operator removes the original lock and tag. If the next operator is delayed, a lock and tag could be installed by the next supervisor. Lockout procedures should indicate how the transfer is to be conducted.
9. It is important that, for their personal protection, each worker and/or fore person working in or on a machine places his/her own safety lock on the disconnect switch. Use tags to spotlight work in progress and give details of work being done. Only when the work is completed and the work permit signed off, may each worker remove his/her lock. The last lock to be removed should be that of the person supervising the lockout and this responsibility should not be delegated.

© Industrial Accident Prevention Association, 2008.

3.6.2 Energy Forms and Lockout Guidelines

Table 3-3 Energy Forms, Energy Sources and General Lockout Guidelines		
Energy Form	Energy Source	Lockout Guidelines
Electrical Energy	<ul style="list-style-type: none"> • Power transmission lines • Machine power cords • Motors • Solenoids • Capacitors (stored electrical energy) 	<ul style="list-style-type: none"> • Turn off power at machine first (i.e., at point of operation switch), and then at the main disconnect switch for the machine. • Lock and tag the main disconnect switch. • Fully discharge all capacitive systems (e.g., cycle machine to drain power from capacitors) according to the manufacturer's instructions.
Hydraulic Energy	<ul style="list-style-type: none"> • Hydraulic systems (e.g., hydraulic presses, rams, cylinders, hammers) 	<ul style="list-style-type: none"> • Shut off, lock (with chains, built-in lockout devices, or lockout attachments) and tag valves. • Bleed off and blank lines as necessary.
Pneumatic Energy	<ul style="list-style-type: none"> • Pneumatic systems (e.g., lines, pressure reservoirs, accumulators, air surge tanks, rams, cylinders) 	<ul style="list-style-type: none"> • Shut off, lock (with chains, built-in lockout devices, or lockout attachments) and tag valves. • Bleed off excess air. • If pressure cannot be relieved, block any possible movement of machinery.
Kinetic Energy (Energy of a moving object or materials. Moving object may be powered or coasting)	<ul style="list-style-type: none"> • Blades • Flywheels • Materials in supply lines 	<ul style="list-style-type: none"> • Stop and block machine parts (e.g. stop flywheels and ensure that they do not recycle). • Review entire cycle of mechanical motion, ensure that all motions are stopped.
		<ul style="list-style-type: none"> • Block material from moving into area of work. • Blank as necessary.
Potential Energy (Stored energy that an object has the potential to release due to its position)	<ul style="list-style-type: none"> • Springs (e.g., in air brake cylinders) • Actuators • Counterweights • Raised loads or movable part of a press or lifting device 	<ul style="list-style-type: none"> • If possible, lower all suspended parts and loads to the lowest (rest) position. • Block parts that might be moved by gravity. • Release or block spring energy.
Thermal Energy	<ul style="list-style-type: none"> • Supply lines • Storage tanks and vessels 	<ul style="list-style-type: none"> • Shut off, lock (with chains, built-in lockout devices, or lockout attachments) and tag valves • Bleed off excess liquids or gases • Blank lines as necessary.

3.7 Ground Connections

Ground connections are in the following locations on the E-Multi Mini controller:

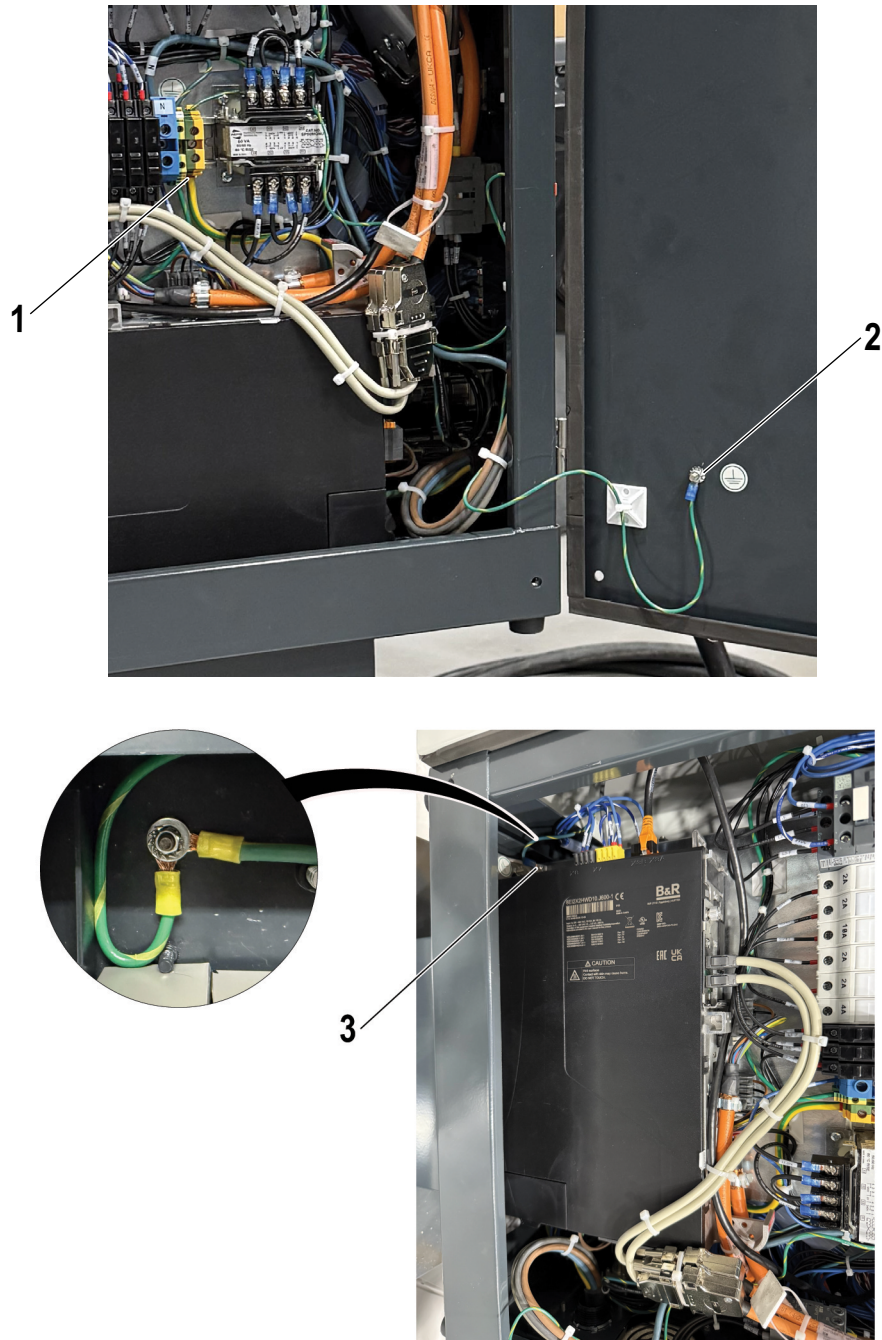

Figure 3-3 Ground connections

	Description
1	Ground connection
2	Ground connection on the door
3	Ground connection on the panel

3.8 Disposal



WARNING

Mold-Masters declines any responsibility for personal injury or personal damage arising from re-use of the individual components, if these parts are used for other than the original and proper intended purpose.

1. Hot runner and system components must be disconnected from the power supply, hydraulics, pneumatics, and cooling before disposal.
2. Make sure that the system to be disposed of is free from fluids. In the case of hydraulic needle valve systems, drain the oil from the lines and cylinders and dispose of it in an environmentally responsible manner.
3. The electrical components are to be dismantled, separating them as environmentally friendly waste or disposed of as hazardous waste if necessary.
4. Remove the wiring. The electronic components are to be disposed of in accordance with your national electric scrap ordinance.
5. Metal parts are to be returned for metal recycling (waste metal and scrap trade). The instructions of the corresponding waste disposal company must be followed.

Recycling of materials should be prioritized during the disposal process.

3.9 Controller Safety Hazards



WARNING

It is crucial to comply with these warnings to minimize any personal danger.

- Ensure that all energies are properly locked out in the controller and molding machine before installation of the controller into the system.
- Do not enter the cabinet without first isolating the supplies or having a qualified person selecting the bypass switch to on, to gain live access to the controller. There are unguarded terminals inside the cabinet which may have a dangerous potential across them. Where a three-phase supply is used, this potential may be up to 600 VAC.
- With the bypass switch set to off, opening the high power section of the controller will cause the circuit breaker to trip, disconnecting all power to the cabinet.
- Voltage and amperage cables are connected to the controller and the mold. There is also a voltage cable connection between the servo motor and the controller. Electric power must be shut off and lockout/tagout procedures followed prior to installing or removing any cables.
- Integration should be done by properly trained personnel based on local codes and regulations. Electrical products may not be grounded when removed from the assembled or normal operating condition.
- Do not mix electrical power cables with thermocouple extension cables. They are not designed to carry the power load or list accurate temperature readings in each other's application.



WARNING

Do not make changes to the factory settings without the help of Mold-Masters service personnel. Changes to these settings can result in hazardous out-of-control or unexpected movement. The changes can also damage the machine and void the warranty.

3.9.1 Operational Environment

The controller should be installed in a clean, dry environment where the ambient conditions do not exceed the following limits:

- Temperature: +5 to +45°C
- Relative Humidity: 90% (non-condensing)

3.9.2 Cabinet Tip (Push) Forces

Table 3-4 Cabinet Push/Tip Forces		
Error Message	EM1/EM2/EM3 Cabinet	EM4 Cabinet
Force required to move a cabinet on castors	13 lbs (6 kgf)	35 lbs (16 kgf)
Force required to tip a cabinet if one castor is missing	150 lbs (68 kgf)	200 lbs (91 kgf)

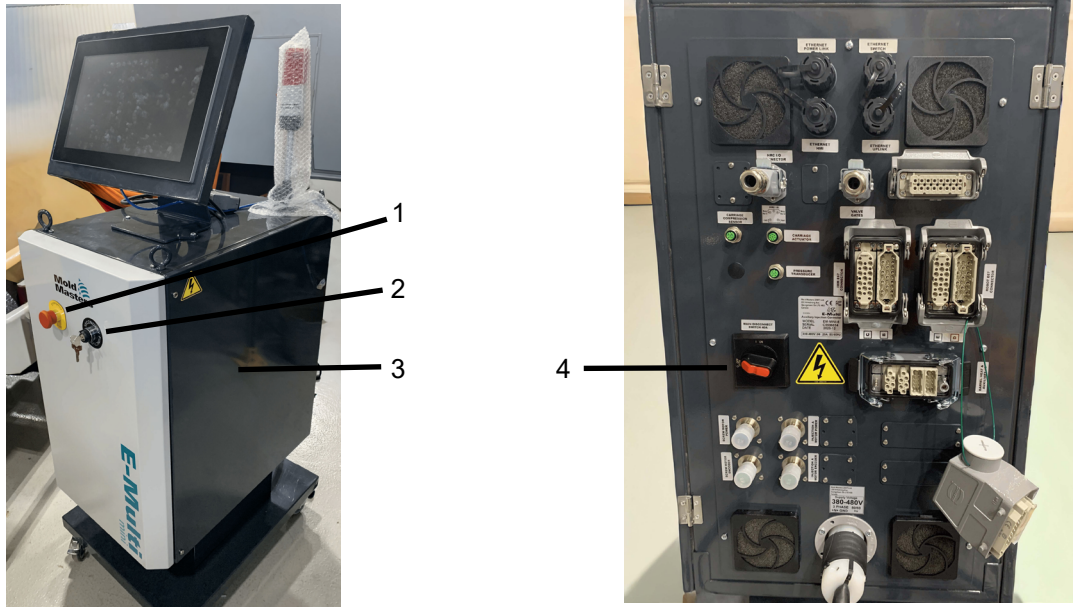

	Description
1	Emergency stop button
2	Secondary-action key switch
3	Side access panel (live components inside)
4	Main power switch

3.10 Unpacking the controller

1. Identify the correct side of the crate to open. This side is marked with the phrase “FRAGILE OPEN THIS SIDE”.
2. Remove the top row of screws from the long side of the crate.
3. Remove the screws from top of crate and remove the top of the crate.
4. From the side of the crate marked with “FRAGILE OPEN THIS SIDE”, remove the cross brace screws.
5. From the side of the crate marked with “FRAGILE OPEN THIS SIDE”, remove the screws down the sides and at the bottom of the crate.
6. Remove the side of the crate marked with “FRAGILE OPEN THIS SIDE”.
7. Remove the remaining four screws holding the braces on the opposite side of the crate and remove the braces.

3.11 Lifting the controller

3.11.1 Preparation



WARNING - TRIP HAZARD

Always ensure that all lifting devices are in good repair and of adequate capacity before commencing work. Failure to lift or support the controller properly can result in severe injury or death and/or damage to the controller.

1. Choose lift equipment that is rated for the prescribed load.
2. Define the load path: the path and orientation the item will move in while it is being lifted, and the location and orientation where it will be set down.
3. Identify and avoid potential pinch points: where an individual or a component of the lifting equipment or load may be caught between two surfaces.
4. Secure and remove all boxes and accessories from the crate and store in a safe location away from the lift path.
5. Remove all cables not attached to the controller from the crate and store in a safe location away from the lift path.

The E-Multi Mini controller is shipped with four eyebolts with threaded studs and four washers. These components are attached to the keys at the back of the controller.

6. Assemble the eyebolts and washers and install in the holes on the top of the E-Multi Mini controller.
7. Attach slings to all of the eyebolts.

IMPORTANT

Slings must be attached securely to all four eyebolts.

Before the controller is lifted more than a small distance, balance the load in the chain or lifting device.

Minimize swinging by bringing the hook over the load appropriately.

Move powered hoists slowly into engagements with loads.

8. Lift the controller from the crate.

Section 4 - Hardware Overview

4.1 Controller Front



Figure 4-1 Controller front

	Description
1	Touchscreen
2	Emergency stop button
3	Secondary-action key switch

4.2 Controller Back (Connections)

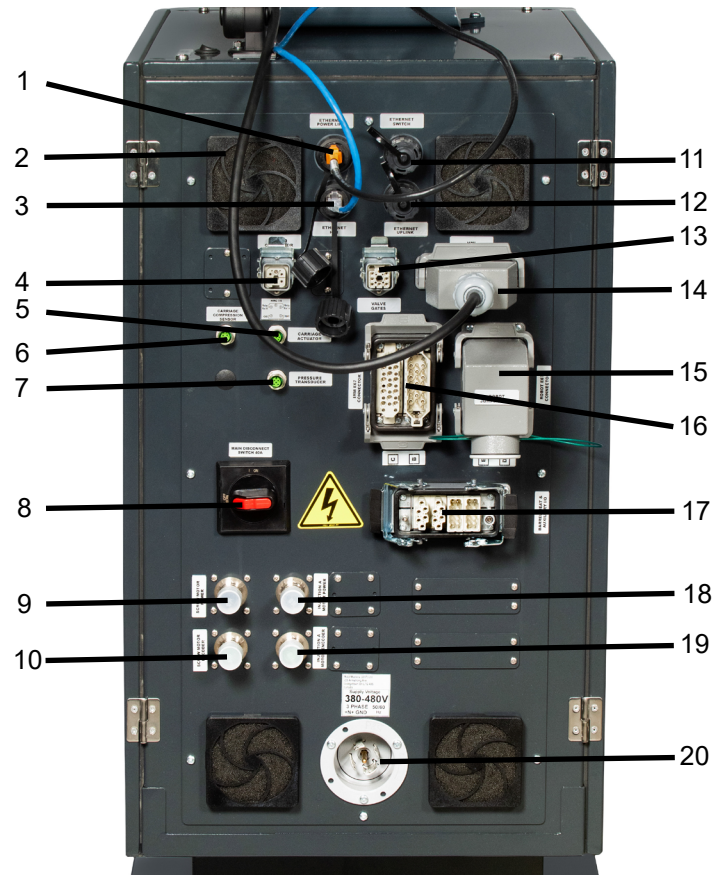

Figure 4-2 Controller rear view (connections)

	Description		Description
1	Ethernet powerlink port	11	Ethernet switch port (optional; for connecting service laptop)
2	Cooling fan with filter	12	Ethernet uplink port (optional; for remote support)
3	Ethernet HMI port	13	Valve gates connector
4	HRC I/O	14	Touchscreen power/data connector
5	Carriage actuator connector	15	Robot E67 connector
6	Carriage compression sensor	16	IMM E67 connector
7	Pressure transducer connector	17	Barrel heats and auxiliary I/O connector
8	Main power switch	18	Injection-motor-power connector
9	Screw-motor-power connector	19	Injection-motor-encoder connector
10	Screw-motor-encoder connector	20	Main-power-supply outlet



Figure 4-3 Diagnostic kit (optional)

Section 5 - Installation

5.1 Introduction



WARNING

- Ensure that you have fully read “Section 3 - Safety” before connecting or operating the controller.
- It is the responsibility of the integrator to understand and follow international and local standards for safety of machinery when integrating the controller with the molding system.
- The E-Multi Mini controller should be located in such a way that the main disconnect is easily accessible in case of emergency.
- The E-Multi Mini controller is shipped with a power cable which is a correct size to run the system. When you install a connector on the cable, ensure that the connector can safely withstand the full system load.
- The E-Multi Mini controller supply should have a fused disconnect or main circuit breaker according to local safety codes. Refer to the serial plate on the controller cabinet for confirmation of the supply requirements. If the local supply is outside the specified range, please contact Mold-Masters for advice.



WARNING-ELECTRICAL SHOCK HAZARD

It is crucial to comply with these warnings to minimize any personal danger.

- Ensure that all energies are properly locked out in the controller and molding machine before installation of the controller into the system.
- Do not enter the cabinet without first isolating the supplies or having a qualified person selecting the bypass switch to on, to gain live access to the controller. There are unguarded terminals inside the cabinet which may have a dangerous potential across them. Where a three-phase supply is used, this potential may be up to 600 VAC.
- With the bypass switch set to off opening the high power section of the controller will cause the circuit breaker to trip, disconnecting all power to the cabinet.
- Voltage and amperage cables are connected to the controller and the mold. There is also a voltage cable connection between the servo motor and the controller. Electric power must be shut off and lockout/tagout procedures followed prior to installing or removing any cables.
- Integration should be done by properly trained personnel based on local codes and regulations. Electrical products may not be grounded when removed from the assembled or normal operating condition.
- Do not transpose electrical power cables with thermocouple extension cables. They are not designed to carry the power load or list accurate temperature readings in each other's application

**WARNING-TRIP HAZARD**

The integrator must ensure that the controller cables do not present a trip hazard on the floor between the controller and the IMM or the E-Multi.

5.2 Connecting the controller to the E-Multi Mini

There are three sets of cables that connect the controller to the E-Multi:

1. Servo power and feedback cables
2. Heater-I/O-IMM cables
3. Sensor cables

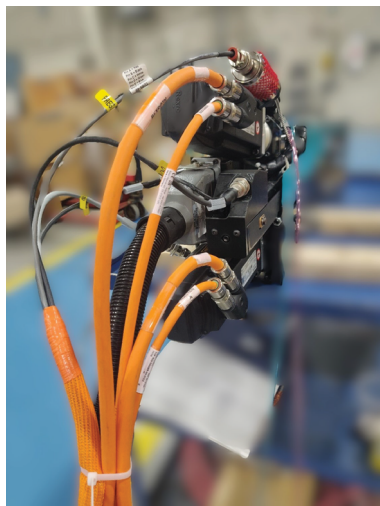

Figure 5-1 Servo cable routing

Cable ties should be used to hold all the cables together and to reduce the stress on the cables. All cables should be routed so they are supported and not pulling on the connectors on the injection unit or the controller. Cables should be routed so they do not interfere with the molding machine.

5.3 Connecting a robot to the controller

E-Multi Mini controllers are compatible with E67 robots. The controller is shipped with a robot jumper plug.

1. If no robot is used, connect the robot jumper plug to the ROBOT E67 connector on the back of the controller.



Figure 5-2 Robot jumper plug

2. If a robot is used, connect the robot's E67 cable to the ROBOT E67 connector on the controller.

5.4 Connecting the controller to the power supply

E-Mini controllers are compatible with E67 injection machines. All controllers ship with an IMM E67 cable. The cable connects to the IMM E67 connector on back of the controller. If used with an E67 IMM, plug the cable into the IMM's E67 connector.

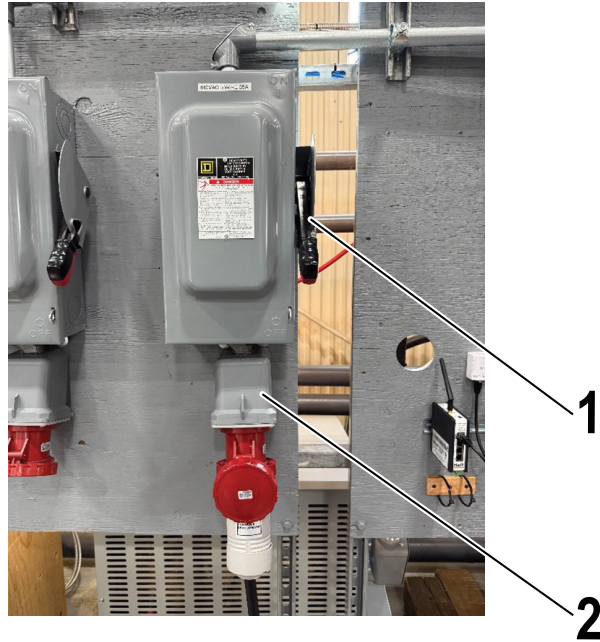

Figure 5-3 Main power source

	Description
1	Main power source
2	Plug of main power source

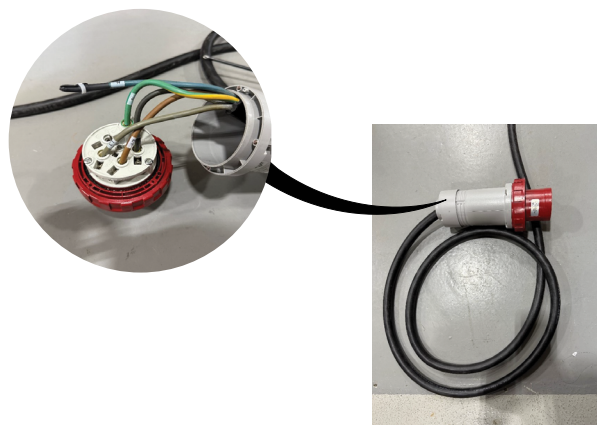

Figure 5-4 Wiring of power cable

5.5 Connecting the controller to the molding machine



Figure 5-5 IMM E67 cable with mold/IMM end and controller end



Figure 5-6 IMM E67 connector on the back of the controller

5.6 Connecting a diagnostic computer (optional)

1. Connect one end of the crossover cable to the Ethernet port on the controller. The Ethernet cable can be connected with the power on.



Figure 5-7 Touchscreen connections

2. Connect the other end of the crossover cable to the Ethernet port on the diagnostic computer. Note that the diagnostic computer may differ from the one shown.
3. Connect the power cable (use the included adapter for 220 V power supplies) of the diagnostic computer to the main power supply.
4. Boot up the diagnostic computer and log in using the credentials that follow.
Username: emulti
Password: nopassword
5. Connect the diagnostic computer to a WIFI network with internet access. To see a list of available networks, click the wireless network icon next to the clock on the taskbar.



NOTE
 The diagnostic computer must be connected to the internet using its wireless network adapter. The wired connection must be used to connect to the controller. Mold-Masters does not support alternate network configurations. Connection problems when using alternate configurations are not covered under warranty and may result in increased support times and additional costs.

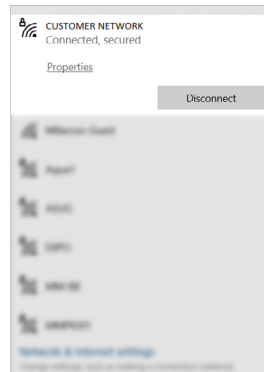

Figure 5-8 Wireless network icon

6. Open a browser and perform a search to verify internet connectivity.

Section 6 - Hardware Operation



WARNING – READ MANUAL BEFORE OPERATION
 Make sure that you have read *section Section 3 - Safety on page 3-1* before operating your E-Multi Mini controller.

6.1 Introduction

Before the E-Multi Mini can be used, the controller must be set up.

Please see *section Section 9 - Software Operation on page 9-1* for details on setting parameters such as:

- Heating
- Control
- Injection speeds
- Trigger signals

6.2 Isolating the controller

For all E-Multi Mini controllers, the main power switch is a rotary circuit breaker at the rear of the cabinet. This switch is rated to safely handle the total load current during switch on and switch off. During maintenance, use a padlock or similar device to lock the switch in the off position to lockout the electrical supply.



Figure 6-1 Main power switch

6.2 Powering on

When the main power switch is turned to on, the servo motors will not be enabled.

Once the software has finished loading and the display shows the Overview screen, the system is in Manual mode and is ready to have the heaters switched on to bring the barrel heaters to operating temperature.

Servo motors are enabled by pressing the motor power button in the left panel of the software. Once the servo motors are enabled, the LED and the border will turn green.



Figure 6-2 Motor and heater power buttons

Refer to *section on page 8-4* for detailed information.

The E-Multi Mini controller can be used in Manual, Setup, or Automatic mode.

6.3 Powering off

Mold-Masters recommends that heaters be switched off before powering off the controller. Turn off the heats using the touchscreen and then switch the controller off using the rotary disconnect on the back of the controller.

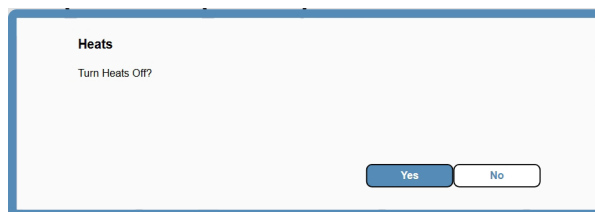

Figure 6-3 Dialog box to power off the heaters

6.3.1 Shut down the heating

Tap the heater power button located in the left panel of the touchscreen.

6.3.2 Shut down the controller

Once heating has been turned off, the system may be turned off using the main switch at the back of the controller.

Refer to *section on page 8-4* for detailed information.

Section 7 - Touchscreen



WARNING – READ MANUAL BEFORE OPERATION

Make sure that you have read *section Section 3 - Safety on page 3-1* before operating your E-Multi Mini controller.

7.1 Introduction



CAUTION

Values in the screen captures in this manual may not reflect the correct values for your machine. Do not change settings based on the screen captures.

This section of the manual describes the touchscreen interface or Human Machine Interface (HMI) and shows what functions and information are available.

From the various screens you will be able to:

- Set individual nozzle temperatures. Set high and low temperature limits for closed loop zone control.
- Configure and calibrate nozzle position and contact force.
- Create mold specific setups (recipes). These can be saved and reloaded when molds are changed.
- Configure the injection sequence and monitor it.
- Configure the hold sequence and monitor it.
- Configure the plasticize sequence and monitor it.
- Use the software oscilloscope (SWO) functionality to monitor operation.
- Control the password protection for all settings.
- Print out any displays or data listings.

Section 8 - Software Overview

8.1 Home Screen

When the title bars are divided into sections with only one highlighted, these are separate tabs that you can select to display more content on the same screen.

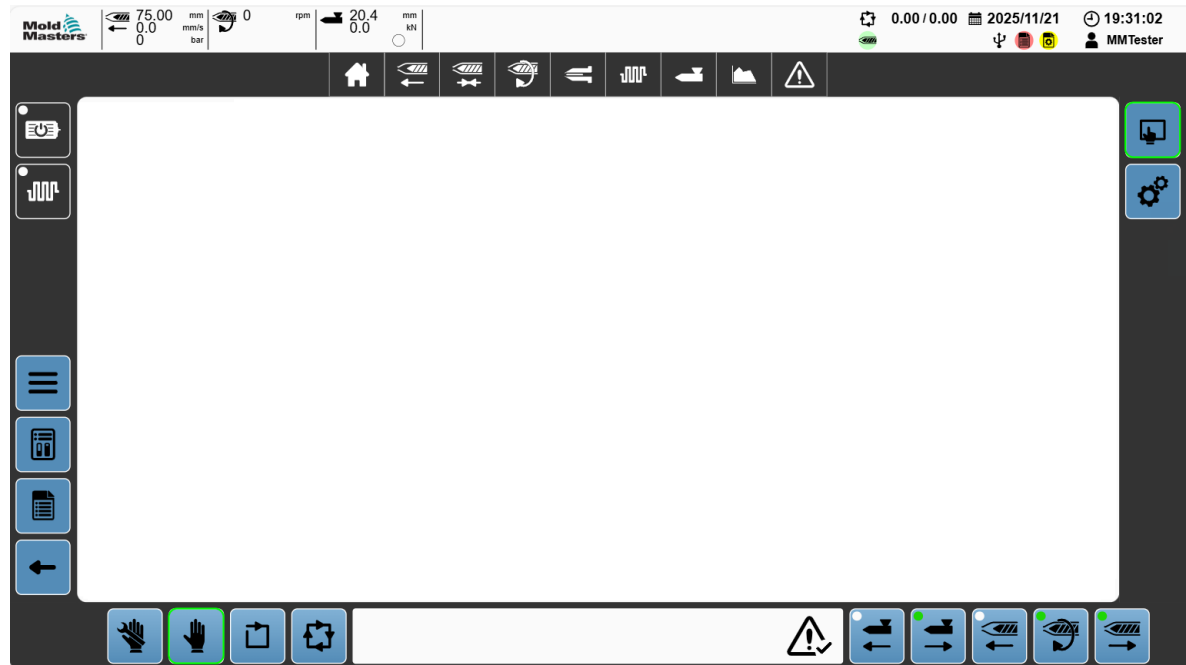

Figure 8-1 Main screen

8.1.1 Header

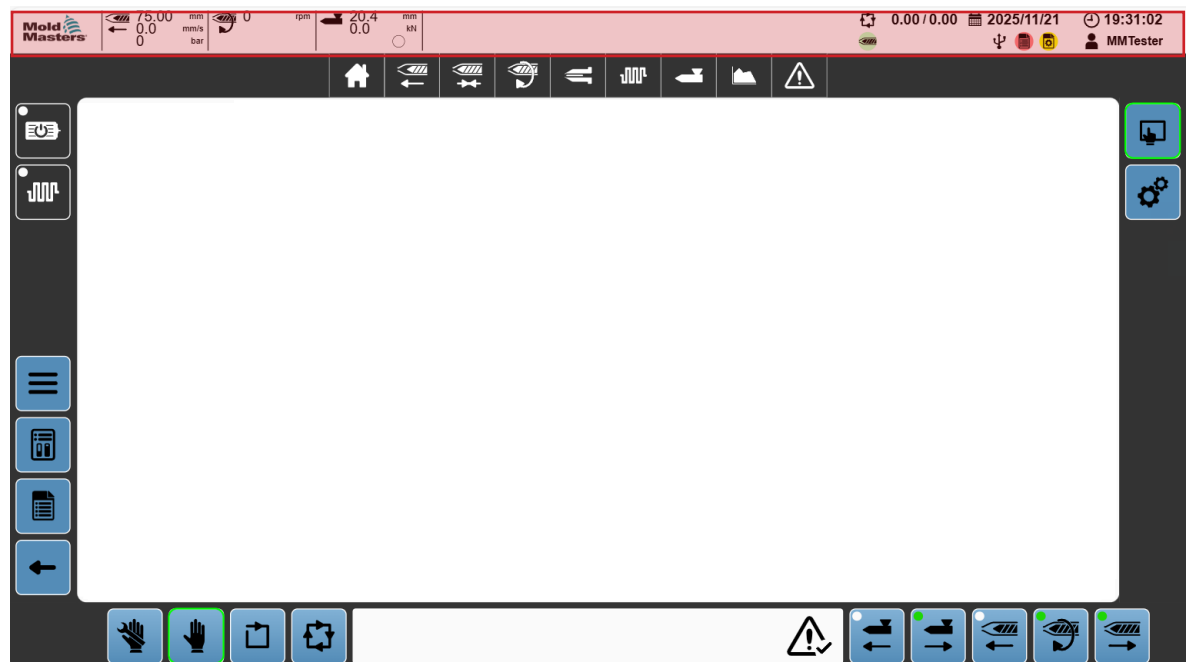





















Figure 8-2 Header

Table 8-1 Header	
Field	Description
	Tap this button to go to the Home screen.
 62.5 mm  0.0 mm/s  0 bar	Displays the injection-axis position, velocity, and injection pressure There is a section for each axis of the machine.
 0.0 rpm	Displays the revolutions per minute (RPM) of the screw
 50.0 mm  0.0 kN 	Displays the position, velocity, and contact force of the carriage axis
 0.00 / 0.00	Displays the current and previous cycle times during automatic cycling
	Displays enabled systems. Enabled systems will have a green background, and disabled systems will not have a green background. Tap this to open the system-enables dialog box
 2024/12/07  14:35:25	Displays the machine's date and time. The date and time can be set on the HMI configuration screen.
 MMTester	Displays the current logged-in user
 2024/12/07  14:35:25     MMTester	Tap anywhere in this area to bring up a login/logout popup window to change profiles or log out.

8.1.2 Navigation Bar

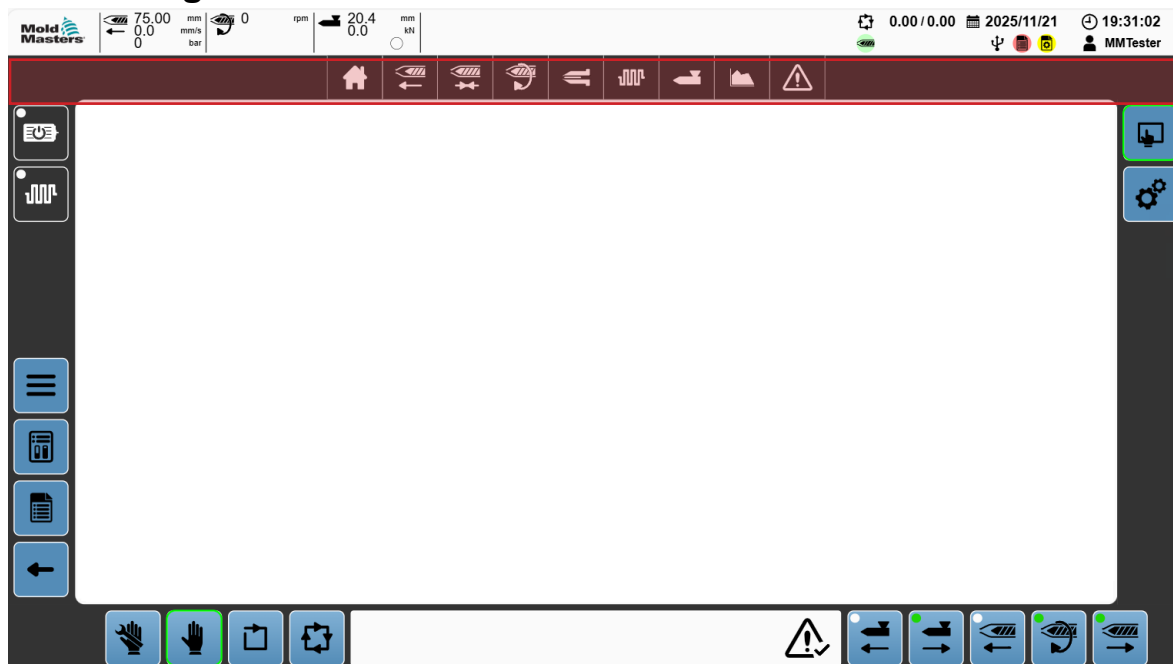

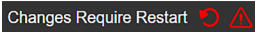

Figure 8-3 Navigation bar of the Main screen

Table 8-2 Navigation Bar	
Button/Panel	Description
	Tap this button to go to the Home screen.
	Tap this button to go to the Injection screen.
	Tap this button to go to the Hold screen.
	Tap this button to go to the Plasticizing screen.
	Tap this button to go to the Carriage screen.
	Tap this button to go to the Valve Gates screen.
	Tap this button to go to the Shutoff Nozzle screen.
	Tap this button to go to the Barrel Heats screen.
	Tap this button to go to the Trace screen.

Table 8-2 Navigation Bar	
Button/Panel	Description
	<p>Tap this button to go to the Alarms screen.</p>
	<p>If changes to the drive, motor, power supply or others require a power cycle, a message is displayed in the top right of the navigation panel.</p> <p>To restart the machine, tap in this area.</p> <p>Tap the Restart button.</p> <div style="border: 1px solid blue; padding: 10px; margin: 10px 0;"> <p style="margin: 0;">Power</p> <p style="margin: 0;">Changes Require Restart</p> <div style="display: flex; justify-content: space-around; margin-top: 10px;"> Restart Ok </div> </div>

8.1.3 Left Panel

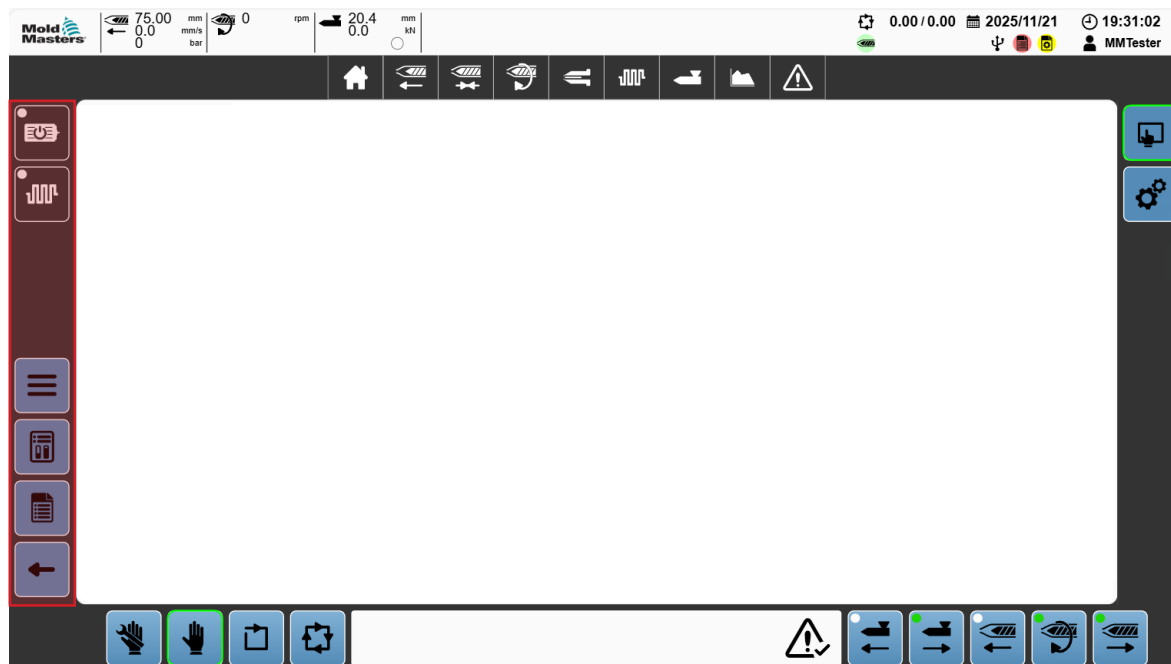



Figure 8-4 Left panel

Table 8-3 Left Panel Buttons	
Button	Description
	Tap this button to power on the motors.
	When the motors are powered, the LED and the border will turn green.
	Tap this button to turn on the barrel heats. When the barrel heats are turned on, the border turns green.
	When the barrel heats are on but below the set temperature, the LED will turn blue.
	When the barrel heats are on and within tolerance but not yet soaked and injection motion has been released, the LED will turn yellow.
	When the barrel heats are on, within tolerance, and soaked, and injection motion has been released, the LED will turn green.
	Tap this button to go to the Screen Directory screen.
	Tap this button to go to the Overview screen.

	Tap this button to go to the Files screen.
	Tap this button to go to the last active screen.

8.1.4 Contextual (Right) Panel

The Contextual menu enables screen-dependent content navigation. The default panel provides links to the Sequence Viewer, the Sequence Editor, and the E67 screen. If a screen has additional subscreens, they will be displayed in the contextual panel. The Injection screen, for example, displays links to subscreens related to the injection axis. If there are no additional subscreens, the default panel will be displayed.

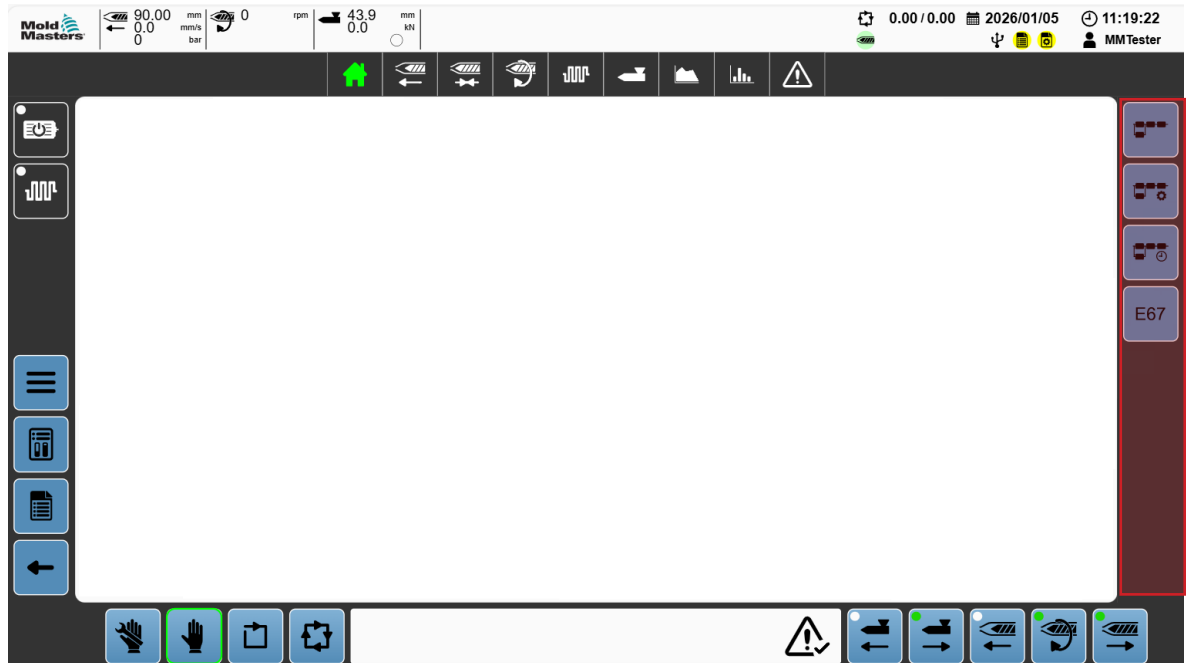

Figure 8-5 Contextual menu of the Main screen

Table 8-4 Contextual Menu Buttons	
Button	Description
	Tap this button to go to the Active-sequence viewer screen.
	Tap this button to go to the Sequence editor screen.
	Tap this button to go to the Wait Points
	Tap this button to go to the Euromap 67 screen.

8.1.5 Footer

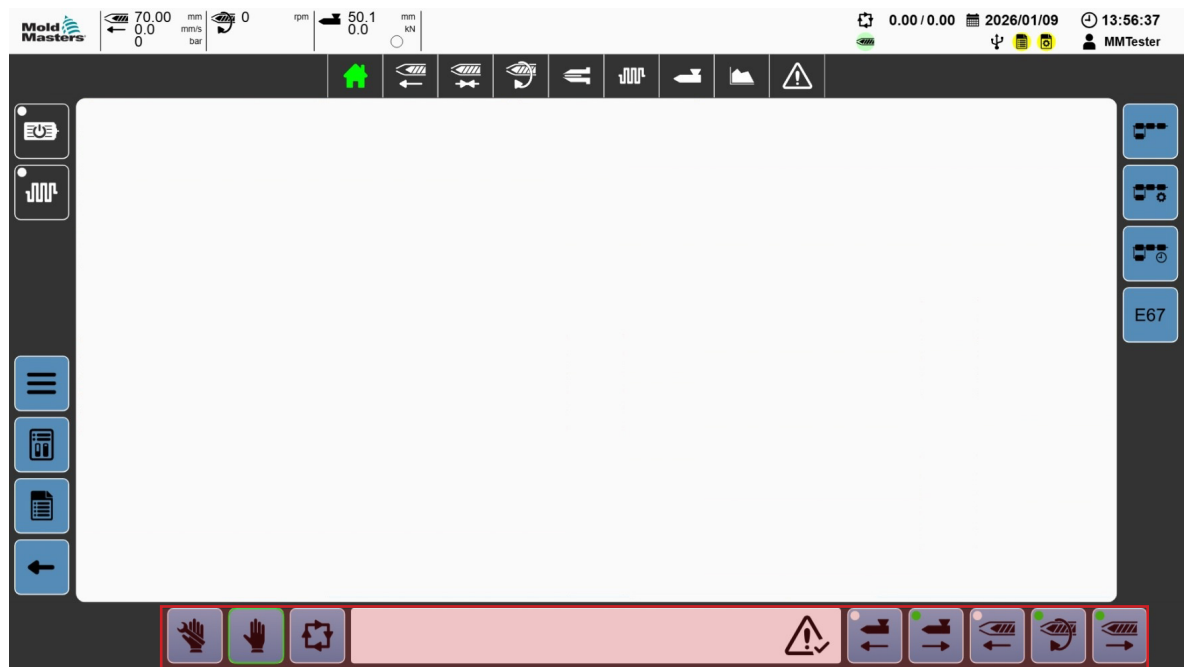

Figure 8-6 Footer

The lower section of the home screen changes based on the option selected:
Recovery, Barrel Heats, Injection.

Table 8-5 Footer Buttons	
Button/ Panel	Description
	Tap this button to put the machine in setup mode. When the machine enters setup mode, the border of the button will turn green.
	Tap this button to put the machine in manual mode. When the machine enters manual mode, the border of the button will turn green.
	Tap this button to put the machine in automatic mode. When the machine enters automatic mode, the border of the button will turn green.
	<p>This alarm panel (center) displays the most recent alarm. If there is an active alarm, this panel will turn red with white text:</p> <p>This panel will also turn red when the system is normal but waiting for a trigger.</p> <p>Tap the acknowledge button to acknowledge all active alarms.</p>



Table 8-5 Footer Buttons	
Button/ Panel	Description
	<p>Tap this button to move the carriage forward towards the mold. Operation depends on the machine mode:</p> <p>LED</p> <ul style="list-style-type: none"> • Off: Axis position is greater than the mold contact position (negative end position) and contact force is not made • Green, blinking: Axis is active in the negative direction • Green, solid: Axis position is within tolerance of the lowest motion step position and contact force is made. <p>Mode</p> <ul style="list-style-type: none"> • Manual <p>Moves the carriage in the negative direction for the optional servo carriage, if the contact position has not been determined, the carriage moves using set-up speed and torque.</p> <p>Once at the contact position the contact force is generated</p> <ul style="list-style-type: none"> • Setup <p>Performs a negative move using the setup velocity and torque</p> <p>Moves forward until the forward motion limit is reached</p> <ul style="list-style-type: none"> • Calibration <p>Jogs the carriage forward using low speed and torque (calibration velocity and torque)</p> <p>For the optional servo carriage, moves until it hits a hard stop, if button is held while against the end stop, axis will calibrate this as the 0 position</p>
	<p>Tap this button to jog the carriage backwards away from the mold. Operation depends on the machine mode:</p> <p>LED:</p> <ul style="list-style-type: none"> • Off: Axis position is less than the sprue break position (positive end position) • Green, blinking: Axis is active in the positive direction • Green, solid: Axis position is within the tolerance of the sprue break position <p>Mode</p> <ul style="list-style-type: none"> • Manual <p>Moves the carriage backward</p> <p>Stops automatically at the sprue break position</p> <p>If you press the button again at the sprue break position, the carriage continues moving back until it reaches the backward hard stop or rear hard stop.</p>

Table 8-5 Footer Buttons	
Button/ Panel	Description
	<ul style="list-style-type: none"> • Setup <p>Moves the carriage backward using low speed and torque (setup velocity and torque)</p> <p>Moves backward until the rear (or backward) hard stop is reached</p> <ul style="list-style-type: none"> • Calibration <p>Performs a positive move using the calibration velocity and torque For the optional servo carriage, moves until it hits a hard stop; if you hold the button while against the end stop, the axis will calibrate this as the maximum position</p>
	<p>Tap this button to jog the injection plunger forward towards the mold. Operation depends on the machine mode:</p> <p>LED:</p> <ul style="list-style-type: none"> • Off: Axis position is greater than the lowest injection profile position (Negative end position) and hold has not been completed • Green, blinking: Axis is active in the negative direction • Green, solid: Axis position is within the tolerance of the lowest injection profile position and hold is completed <p>Mode</p> <ul style="list-style-type: none"> • Manual <p>Moves the injection plunger forward</p> <p>If the E67 Mold Closed signal is low or the carriage contact force is not built, injects using purge speed and pressure, otherwise uses the set injection and hold profile settings.</p> <ul style="list-style-type: none"> • Setup <p>Moves the injection plunger forward using the setup velocity, torque, and injection pressure limits</p> <p>Moves the injection plunger until it is fully forward</p> <ul style="list-style-type: none"> • Calibration <p>Moves the injection plunger forward using the calibration velocity and torque limits with no injection pressure limiting</p> <p>Moves until it hits a hard stop; if the button is held while against the end stop, the axis will calibrate this as the zero position</p>



Table 8-5 Footer Buttons	
Button/ Panel	Description
	<p>Tap this button to rotate the screw. Operation depends on machine mode:</p> <p>LED</p> <ul style="list-style-type: none"> • Off: Axis position is less than the final plasticizing profile position (positive end position) • Green, blinking: Axis is active in the positive direction. • Green, solid: Axis position is within tolerance of the final plasticizing profile position. <p>Mode</p> <ul style="list-style-type: none"> • Manual <p>Moves the injection screw in the positive direction</p> <p>Does decompression before feed movement first, if not already performed, then stops</p> <p>If button pressed again after decompression before feed, rotates the screw until final plasticizing profile position is reached then stops</p> <p>If button pressed again after plasticizing complete, retracts screw (decompression) until final plasticizing profile position plus decompression after feed stroke is reached</p> <ul style="list-style-type: none"> • Setup <p>Performs a positive move (rotation) using the setup velocity and torque Moves backward until the positive motion limit is reached</p> <ul style="list-style-type: none"> • Calibration <p>Performs a positive move using the calibration velocity and torque Moves backward until the positive motion limit is reached</p>
	<p>Tap this button to move the injection plunger backward. Operation depends on machine mode:</p> <p>LED</p> <ul style="list-style-type: none"> • Off: Axis position is less than the plasticizing end plus decompression after feed position (positive end position) • Green, blinking: Axis is active in the positive direction • Green Solid: Axis position is within the tolerance of the plasticizing end plus decompression after feed position

Table 8-5 Footer Buttons	
Button/ Panel	Description
	<p>Mode</p> <ul style="list-style-type: none"> • Manual <p>Moves the injection in the positive direction</p> <p>Does decompression before feed movement first, if not already performed, then stops</p> <p>If you tap the button again after decompression before feed, retracts the screw (decompression) until final plasticizing profile position plus decompression after feed stroke is reached</p> <ul style="list-style-type: none"> • Setup <p>Preforms a positive move using the setup velocity and torque</p> <p>Moves backward until the positive motion limit is reached</p> <ul style="list-style-type: none"> • Calibration <p>Preforms a positive move using the calibration velocity and torque</p> <p>Moves until it hits a hard stop; if you hold the button while against the end stop, the axis will calibrate this as the maximum position</p>

8.2 Screen Directory

8.2.1 E-Multi Mini Directory

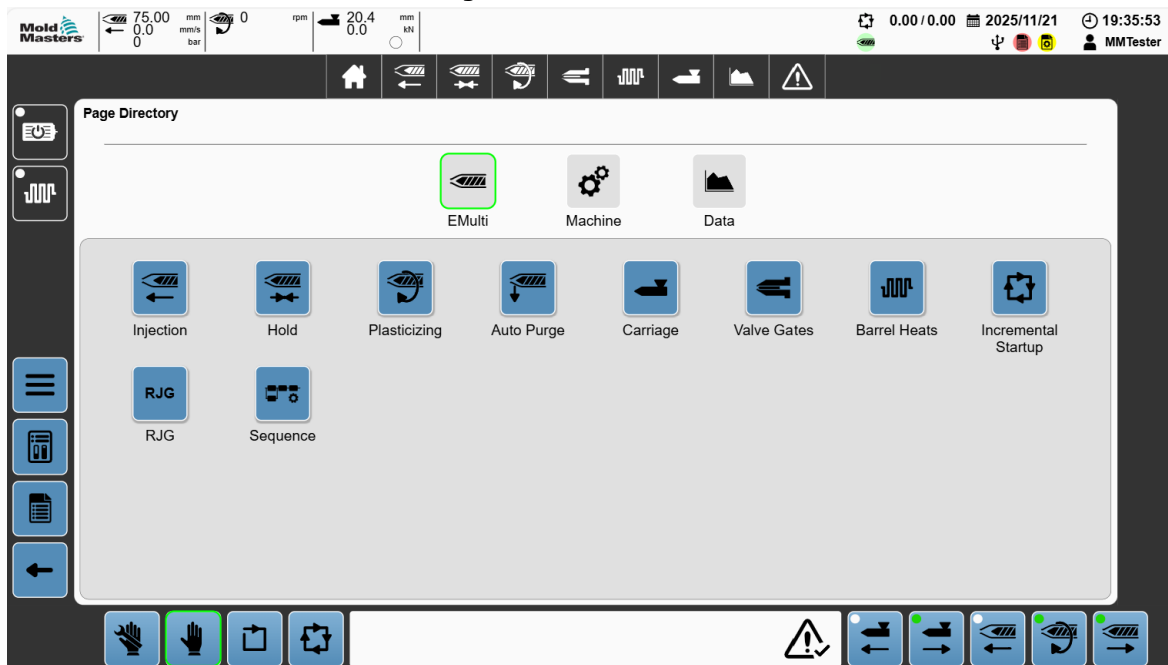

Figure 8-7 Directory screen with E-Multi button selected

Table 8-6 Directory Screen	
Button	Description
	Tap this button to go to the Injection screen.
	Tap this button to go to the Hold screen.
	Tap this button to go to the Plasticizing screen.
	Tap this button to go to the Recovery screen.
	Tap this button to go to the Carriage screen.
	Tap this button to go the Valve Gates screen.
	Tap this button to go to the Barrel Heats screen.
	Tap this button to go to the Incremental Startup screen.

	<p>Tap this button to go to the RJG screen.</p>
	<p>Tap this button to go to the Sequence Editor screen. <i>Note:</i> This is only available for user levels above Operator</p>

8.2.2 Machine Directory

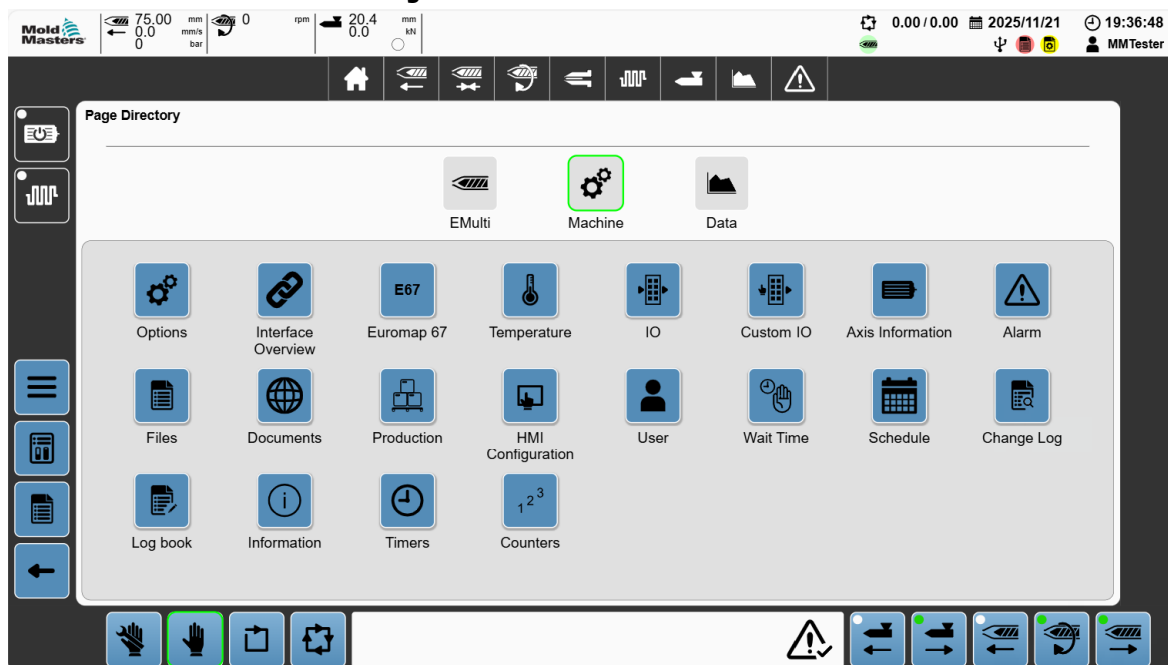















Figure 8-8 Screen directory with Machine button selected

Table 8-7 Machine Directory	
Button	Description
	<p>Tap this button to go to the Machine Options screen. <i>Note:</i> This is only available for user levels of MMTester and higher</p>
	<p>Tap this button to go to the Interface Overview screen.</p>
	<p>Tap this button to go to the Euromap 67 screen.</p>
	<p>Tap this button to go to the Temperature screen.</p>
	<p>Tap this button to go to the Machine Inputs and Outputs screen.</p>
	<p>Tap this button to go to the Custom IO screen.</p>

Table 8-7 Machine Directory	
Button	Description
	Tap this button to go to the Axis Information screen.
	Tap this button to go to the Alarm screen.
	Tap this button to go to the Files screen. On the Files screen you can control the recipe, fixed, and user data.
	Tap this button to go to the Documents screen. <i>Note:</i> This screen displays controller schematics and the user manual. If you are logged in as an admin, you can view advanced systems diagnostics here.
	Tap this button to go to the Production screen.
	Tap this button to go to the HMI Configuration screen.
	Tap this button to go to the User Management screen. <i>Note:</i> You must login as admin to view the User Management screen.
	Tap this button to go to the Wait Timers screen.
	Tap this button to go to the Schedule screen.
	Tap this button to go to the Change Log screen.
	Tap this button to go to the Log Book screen.
	Tap this button to go to the Machine Info screen.
	Tap this button to go to the Timers screen.
	Tap this button to go to the Counters screen.

8.2.3 Data Directory

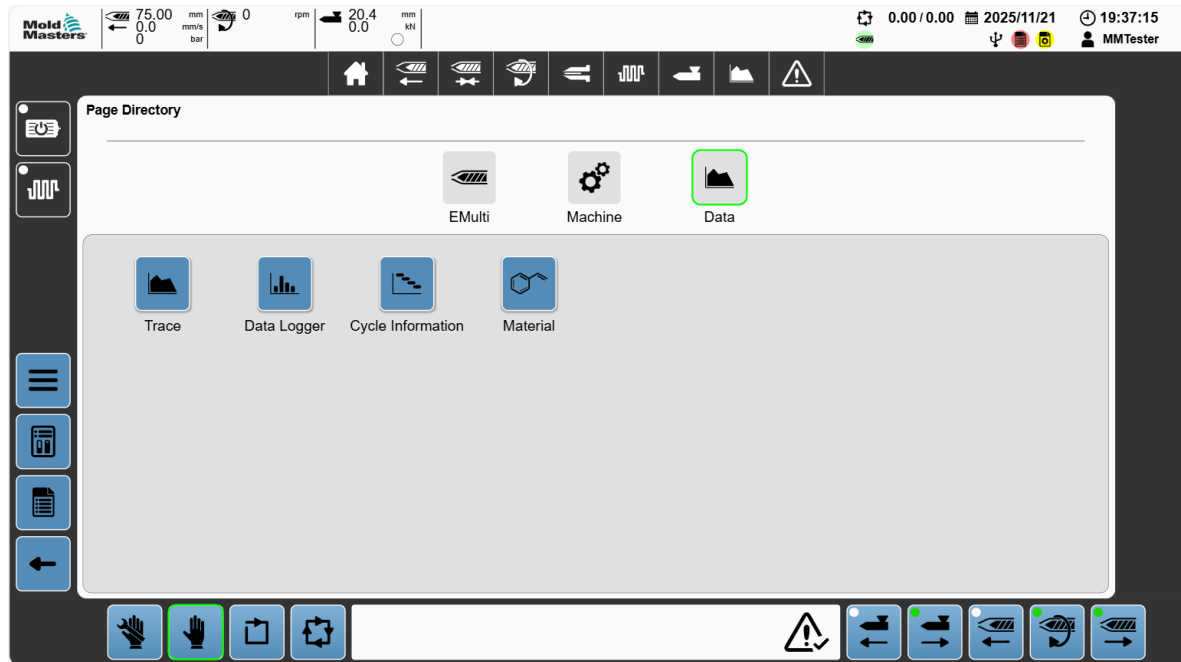

Figure 8-9 Screen directory with Data button selected

Table 8-8 Data Directory	
Button	Description
	Tap this button to go to the Trace screen.
	Tap this button to go to the Data Logger screen.
	Tap this button to go to the Cycle Information screen.
	Tap this button to go to the Material Data screen.

8.3 Overview

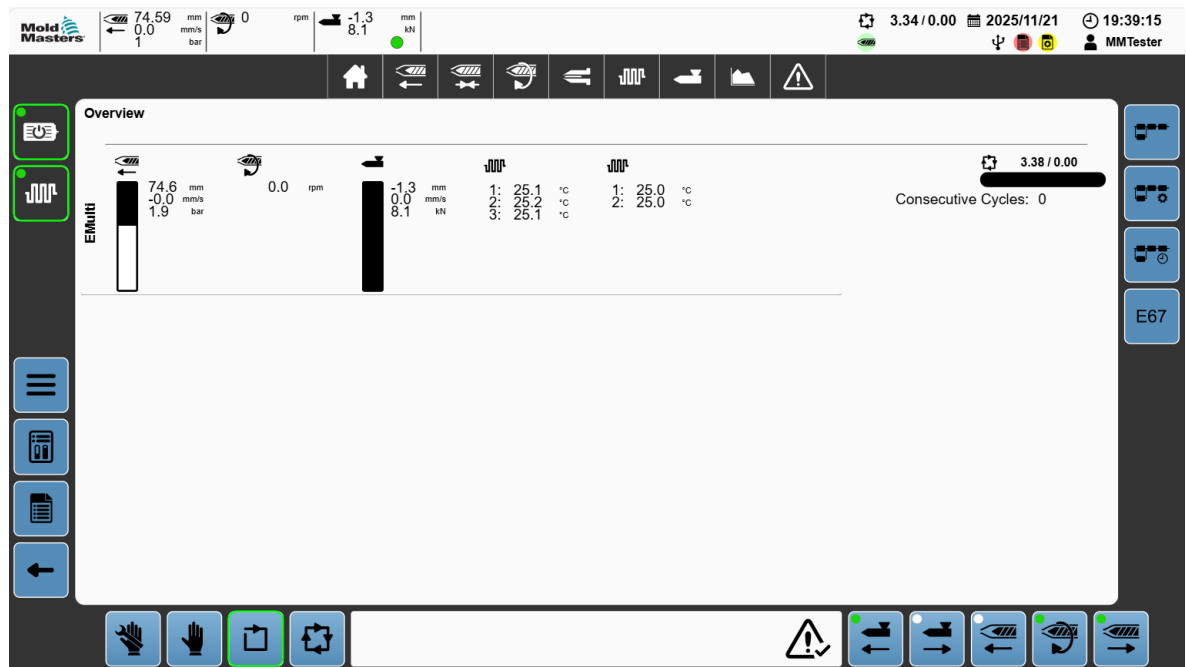

Figure 8-10 Overview screen

The Overview screen shows following basic details of all the axes of the E-Multi Mini system:

- Position, speed, and pressure for the injection
- Rotation, speed for the plasticizing screw
- Position, speed, and contact force for the carriage
- Actual temperatures for the barrel heats
- Basic cycle information
- A bar graph indicating the current position as a portion of the total stroke is provided for each axis with position feedback

Tap on the respective bar graph to go to the main screen for that bar.

8.4 Injection

Tap the following buttons in the order shown to go to the Injection Screen.

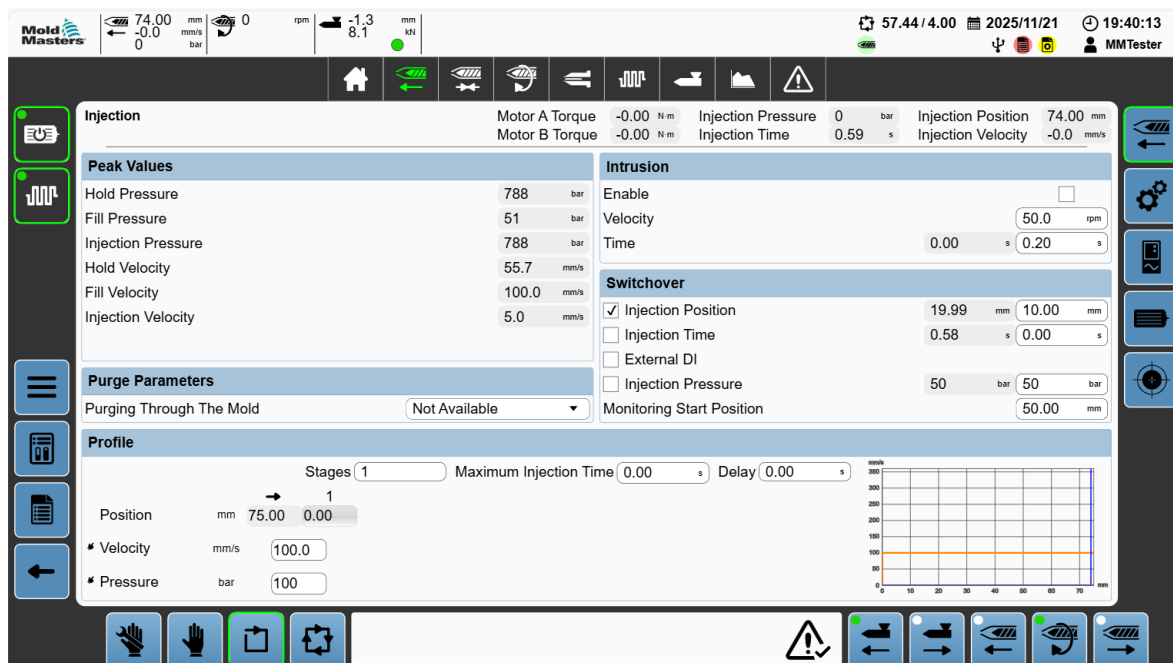
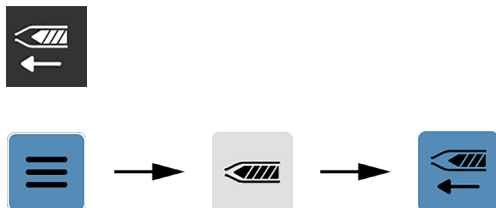

Figure 8-11 Injection screen with Intrusion tab selected

Table 8-9 Peak Values Panel	
Field	Description
Hold Pressure	Peak injection pressure during injection hold
Fill Pressure	Peak injection pressure during injection fill
Injection Pressure	Peak injection pressure during entire injection (boost and hold)
Hold Velocity	Peak velocity during injection hold
Fill Velocity	Peak velocity during injection fill
Injection Velocity	Peak velocity during entire injection (boost and hold)

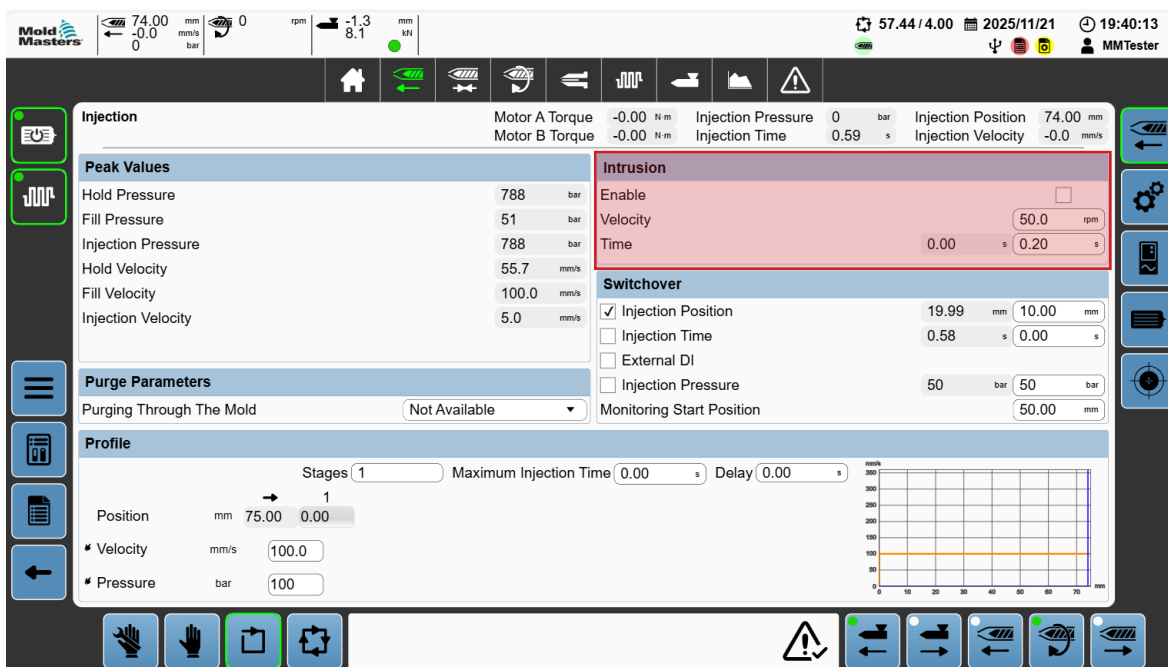

Figure 8-12 Injection screen with Intrusion panel highlighted

Table 8-10 Intrusion Panel	
Field	Description
Enable	Click the check box to enable intrusion (use plasticizing to partially fill the mold cavity)
Velocity	Screw rotational speed during intrusion Values: 0 rpm to 500 rpm
Time	Intrusion run time Values: 0 s to 60 s

Table 8-11 Switchover Panel	
Field	Description
<input checked="" type="checkbox"/> Injection Position 0.0 mm 20.0 mm	Click the check box to enable switchover via injection position. Grey field - Actual injection position at switchover Value field - Set injection position for switchover Values: 0 mm to 125 mm
<input type="checkbox"/> Injection Time 0.00 s 0.00 s	Click the check box to enable switchover via injection time. Grey field - Actual injection time at switchover Value field - Set injection time for switchover Values: 0 s to 10,000 s

Table 8-11 Switchover Panel	
Field	Description
<input type="checkbox"/> External DI	Click the check box to enable switchover via digital input signal.
<input type="checkbox"/> Injection Pressure 0 bar 50 bar	Click the check box to enable switchover via injection pressure. Grey field - Actual injection pressure at switchover Value field - Set injection pressure for switchover Values: 0 bar to 1280 bar
Monitoring Start Position 50.0 mm	Injection position at which to start monitoring pressure for switchover. Values: Any negative value up to maximum positive value in mm

Table 8-12 Purge Parameters Panel	
Field	Description
Purging Through the Mold	This controls how the injection unit responds to inject in manual mode when the carriage is forward and under contact force but the E67 interface indicates that the mold is not closed. Not Available—Injection is not allowed With Purge Settings—Injection allowed using reduced purge speed and pressure limits With Auto Settings—Injection allowed using normal auto mode injection profile speed and pressure settings

Table 8-13 Profile Panel	
Field	Description
Stages	Number of stages in the injection profile Values: 1 to 10
Maximum Injection Time	Maximum allowed injection time Values: 0 s to 10,000 s
Delay	Injection start delay time Values: 0 s to 60 s

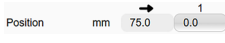
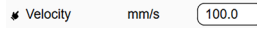





Table 8-13 Profile Panel	
Field	Description
	<p>Injection stage end positions</p> <p>Position at which current stage settings end and next stage settings begin.</p> <p>Example settings: stage 1 of injection is from 95 mm to 50 mm, stage 2 from 50 mm to 40 mm, stage 3 from 30 mm to 20 mm, and stage 4 from 20 mm to 5 mm</p> <p>No further injection is allowed past the final stage end position (5 mm in the example case).</p> <p>The actual value before the first stage position is the injection start position (plasticizing end stop plus the decompression after feed stroke)</p> <p>Values: Any positive value up to the previous stage stroke value</p>
	<p>Injection velocity set points for each stage</p> <p>Values: 0 mm/s to 360 mm/s</p>
	<p>Injection pressure limit for each stage</p> <p>Values: 0 bar to 1280 bar injection pressure</p>

Table 8-14 Contextual Menu Buttons	
Field	Description
	<p>Tap this button to go to the Main-axis/operation (injection) screen.</p>
	<p>Tap this button to go to the Injection configuration screen. Use this screen to set values and limits for general parameters, motion parameters, and sensor setup.</p>
	<p>Tap this button to go to the Injection drive screen. Use this screen to set values for servo drive PID controllers and encoders.</p>
	<p>Tap this button to go to the Injection motor screen.</p>
	<p>Tap this button to enter calibration mode. When the machine enters calibration mode, the border of the button will turn green.</p> <p><i>Note:</i> This button is only visible when the logged-in user has commissioning permissions.</p>

8.4.1 Calibration

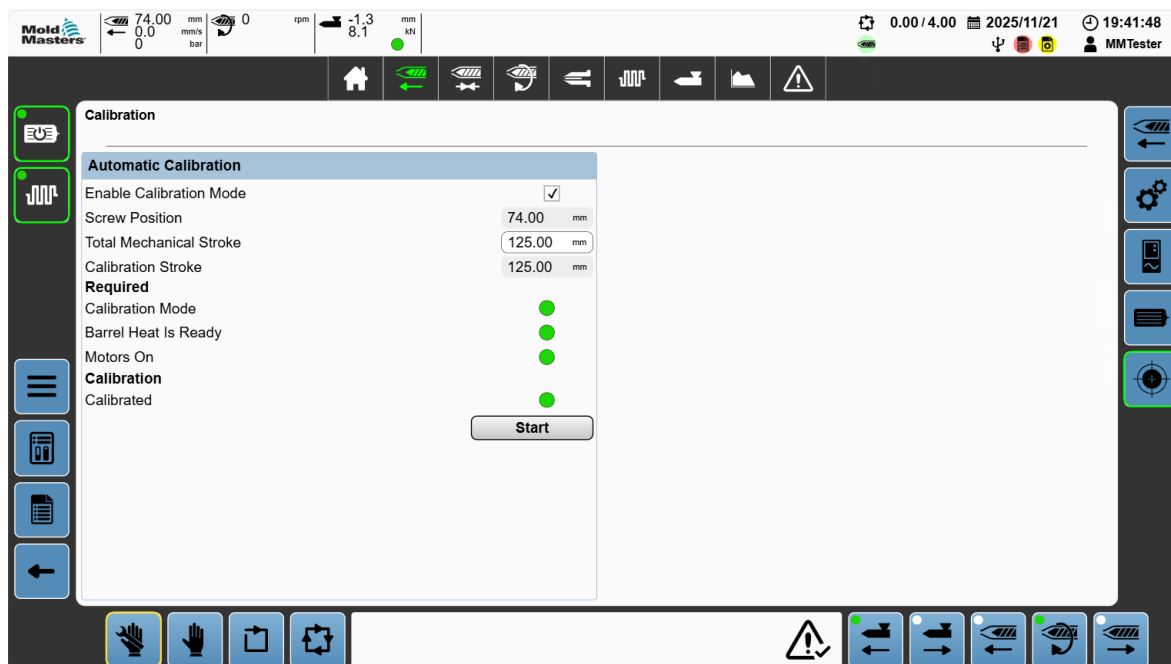

Figure 8-13 Calibration screen

Table 8-15 Calibration Screen	
Field/Button	Description
Enable Calibration mode	Tap this checkbox to enter calibration mode. Calibration of the axis or changing screens will automatically exit calibration mode. Note: Checkbox is enabled only in setup mode. The border will turn yellow around the setup mode button.
Screw Position	Actual screw position in mm
Total Mechanical Stroke	Physical maximum of axis stroke Values: Any negative value up to maximum positive value same field as: Axis Configuration > General > Total Mechanical Stroke
Calibration Stroke	Position taken over during calibration at positive end stop Value: Total Mechanical Stroke - Minimum Position Stroke Offset
Required	
Calibration Mode	Prerequisite for automatic calibration: Green - If the machine is in calibration mode, the LED will be green. Off - If the machine is not in calibration mode, the LED will be off.

Table 8-15 Calibration Screen	
Field/Button	Description
Barrel Heat is Ready	<p>Prerequisite for automatic calibration:</p> <p>Green – If the barrel heats are on and soaked, the LED will be green.</p> <p>Off – If the barrel heats are off / not soaked, the LED will be off.</p>
Motors On	<p>Prerequisite for automatic calibration:</p> <p>Green - If the machine have the motors on, the LED will be green.</p> <p>Off - If the machine have the motors on, the LED will be off.</p>
Calibration	
Calibrated	<p>Green - If the axis has been calibrated successfully, the LED will be green.</p> <p>Off - If the axis has been calibrated successfully, the LED will be off.</p>
<div style="border: 1px solid black; border-radius: 10px; padding: 5px; width: fit-content; margin: auto;">Start</div>	<p>Start automatic calibration:</p> <p>Make sure that the axis can move the full stroke unobstructed. Tap the Start button to begin an automatic calibration.</p> <p>Procedure</p> <p>The axis moves according to the calibration parameters set on the Axis Configuration screen.</p> <ol style="list-style-type: none"> 1. The axis moves positive until it hits a hard stop. 2. The axis is homed to the maximum position. 3. The axis moves negative until it hits a hard stop. 4. If the hard stop position is within the forward tolerance of the 0 position, then automatic calibration is successful and the calibrated LED turns green. 5. If automatic calibration fails, an error is displayed.

8.5 Hold

Tap the following buttons in the order shown to go to the Hold screen.

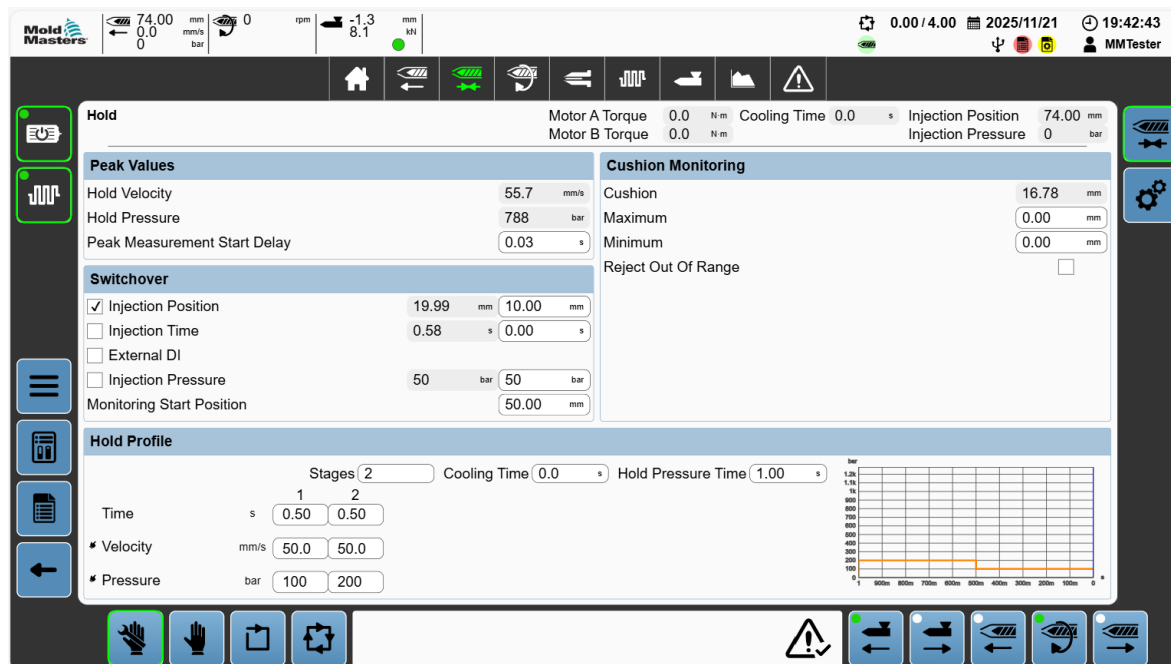
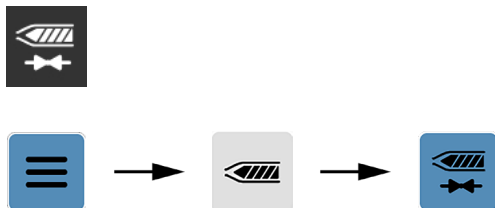

Figure 8-14 Hold screen

Table 8-16 Peak Values Panel	
Field	Description
Hold Velocity	Peak velocity during injection hold
Hold Pressure	Peak injection pressure during injection hold
Peak Measurement Start Day	Delay to measure the peak values in seconds

Table 8-17 Cushion Monitoring Panel	
Field	Description
Cushion	Actual cushion (screw position at end of injection and hold)
Maximum	Maximum allowed cushion at end of injection and hold Values: 0 mm to 125 mm
Minimum	Minimum allowed cushion at end of injection and hold Values: 0 mm to 125 mm
Reject Out of Range	Click the check box to enable reject output activated if actual cushion is out of range

Table 8-18 Switchover Panel	
Field	Description
<input checked="" type="checkbox"/> Injection Position 0.0 mm 20.0 mm	Injection Position: Click the check box to enable switchover via injection position, actual injection position at switchover; set injection position for switchover Values:0 mm to 125 mm
<input type="checkbox"/> Injection Time 0.00 s 0.00 s	Injection Time: Click the check box to enable switchover via injection time; actual injection time at switchover; set injection time for switchover Values:0 mm to 125 mm
<input type="checkbox"/> External DI	External DI (digital input): Click the check box to enable switchover via digital input signal
<input type="checkbox"/> Injection Pressure 0 bar 50 bar	Injection Pressure: Click the check box to enable switchover via injection pressure; actual injection pressure at switchover; set injection pressure for switchover Values:0 bar to 1280 bar
Monitoring Start Position 100,000.0 mm	Monitoring Start Position: The injection position at which to start monitoring pressure for switchover Values: Any negative value up to maximum positive value

Table 8-19 Hold Profile Panel	
Field	Description
Stages	Number of stages in the injection profile Values: 1 and 10
Cooling Time	Cooling time after hold completed Values: Any negative value up to maximum positive value
Hold Pressure Time	Injection hold total time Sum of all Hold stages set times Values: 0 s to 10,000 s
Time s <input type="text" value="0.50"/> <input type="text" value="0.50"/> <input type="text" value="0.50"/> <input type="text" value="0.50"/> <input type="text" value="0.50"/>	Time: Values: 0 s to 10,000 s
Velocity mm/s <input type="text" value="50.0"/> <input type="text" value="50.0"/> <input type="text" value="50.0"/> <input type="text" value="50.0"/> <input type="text" value="50.0"/>	Velocity: Values: 0 mm/s to 360 mm/s
Pressure bar <input type="text" value="100"/> <input type="text" value="100"/> <input type="text" value="100"/> <input type="text" value="100"/> <input type="text" value="100"/>	Pressure: Values: 0 bar to 1280 bar

8.6 Plasticizing

Tap the following buttons in the order shown to go to the Plasticizing screen.

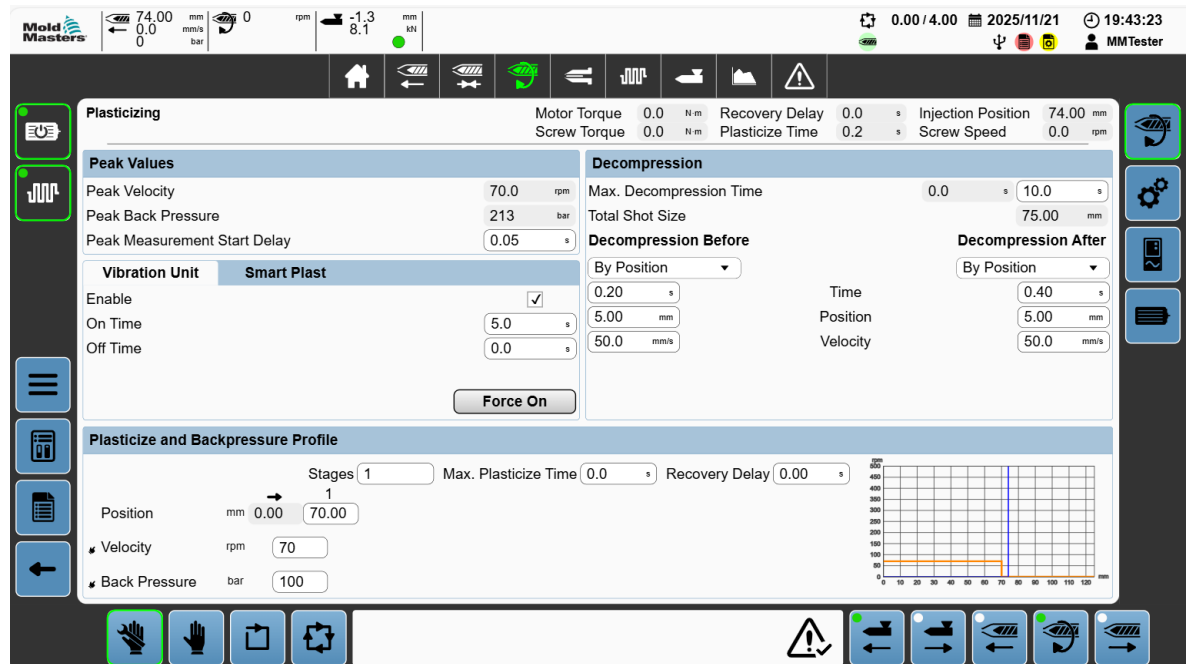
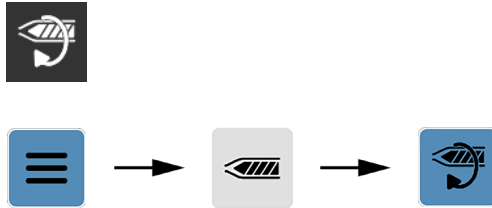

Figure 8-15 Plasticizing screen

Table 8-20 Peak Values Panel	
Field	Description
Peak Velocity	The maximum recorded rotational velocity of the plasticizing screw during automatic mode plasticizing.
Peak Back Pressure	The maximum recorded back pressure during automatic mode plasticizing.
Peak Measurement Start Delay	Delay time from the beginning of plasticizing to start recording peak back pressure.

Table 8-21 Smart Plasticizing Tab	
Field	Description
Enable	Click the check box to enable the Smart Plasticizing feature When enabled, Smart Plasticizing finds the minimum cycle time and adjusts the plasticizing speed so that plasticizing takes between 90 and 95 percent of the available time between injection finishing on one cycle and the start of the next injection.
Minimum RPM	Minimum screw RPM allowed during adjustments
Maximum RPM	Maximum screw RPM allowed during adjustment
RPM Adjustment	Current screw RPM adjustment applied to profile set screw speed.





Table 8-22 Vibration Unit Tab	
Field	Description
Enable	Click the check box to enable the feed vibration unit Vibrates the feed throat during plasticizing to prevent any material feed blockages. Cycles on and off for set times while plasticizing is active
On Time	Set time vibration is on during the active cycle Values: 0 to 10,000 s
Off Time	Set time vibration is off during the active cycle Values: 0 to 10,000 s
	Force On button Tap this button to activate the vibration unit when the machine is in manual and the push button is pressed.

Table 8-23 Decompression Panel	
Field	Description
Max. Decompression Time	Maximum allowed runtime for decompression actions Values: 0 s to 10,000 s

Table 8-23 Decompression Panel	
Field	Description
Decompression Before	<p>Tap this field to select the method for decompression before feed.</p> <p>Values:</p> <ul style="list-style-type: none"> • Off - No decompression before feed • By Position - Decompression before feed to a position relative to the screw position at the end of hold • By Time - Decompression before feeding for a set amount of time
Time	<p>Length of time to run decompression before feed when decompression before by time is selected</p> <p>Values: 0 s to 10,000 s</p>
Position	<p>Decompression stroke required before beginning of plasticizing</p> <p>Values: 0 mm to 5 mm</p> <p>A relative offset to the screw position at the end of injection and hold, i.e. if the cushion at the end of hold is 8 mm and decompression before position is 5 mm, the screw will pull back (decompress) to 13 mm before starting plasticizing</p>
Velocity	<p>Screw linear velocity during decompression before motions</p> <p>Values: 0 mm/s to 270 mm/s</p>
Decompression After	<p>Tap this field to select the method for decompression after feed.</p> <p>Values:</p> <ul style="list-style-type: none"> • Off - No decompression after feed • By Position - Decompression after feed to a position • By Time - Decompresses after feed for a set amount of time
Time	<p>Length of time to run decompression after feed when decompression after by time selected</p> <p>Values: 0 s to 10,000 s</p>
Position	<p>Decompression stroke required after plasticizing completes</p> <p>A relative offset to the screw position at the end of plasticizing; for example, if the plasticizing profile end position is 75 mm and the decompression after position is 5 mm, the screw will pull back (decompress) to 80 mm at the end of plasticizing.</p> <p>Values: 0 mm to 125 mm</p>
Total Shot Size	Calculated value

Table 8-23 Decompression Panel	
Field	Description
Velocity	Screw linear velocity during decompression after motions Values: 0 mm to 270 mm

Table 8-24 Plasticize and Backpressure Profile Panel	
Field	Description
Stages	Number of stages in the plasticizing profile Values: 1 to 10
Max. Plasticize Time	Maximum allowed plasticizing time Values: 0 s to 10,000 s
Recovery Delay	Plasticizing start delay time Values: 0 s to 60 s
Position mm  1 <input type="text" value="0.0"/> <input type="text" value="70.0"/>	Plasticizing stage end positions Position at which current stage settings end and next stage settings begin For example, setting stage 1 of the injection is from 95 mm to 50 mm, stage 2 from 50 mm to 40 mm, stage 3 from 30 mm to 20 mm, and stage 5 from 20 mm to 5 mm No further injection is allowed past the final stage end position (5 mm in the example case). The actual value before first stage position is the injection start position (plasticizing end stop plus the decompression after feed stroke). Values: 0 mm to 125 mm
 Velocity rpm <input type="text" value="100.0"/>	Plasticizing velocity set points for each stage Values: 0 rpm to 500 rpm
 Back Pressure bar <input type="text" value="5"/>	Plasticizing back pressure target for each stage The screw will be pulled back automatically as needed during plasticizing to maintain back pressure. Values: 0 bar to 300 bar

8.7 Auto Purge

Tap the following buttons in the order shown to go to the Auto-Purge screen.

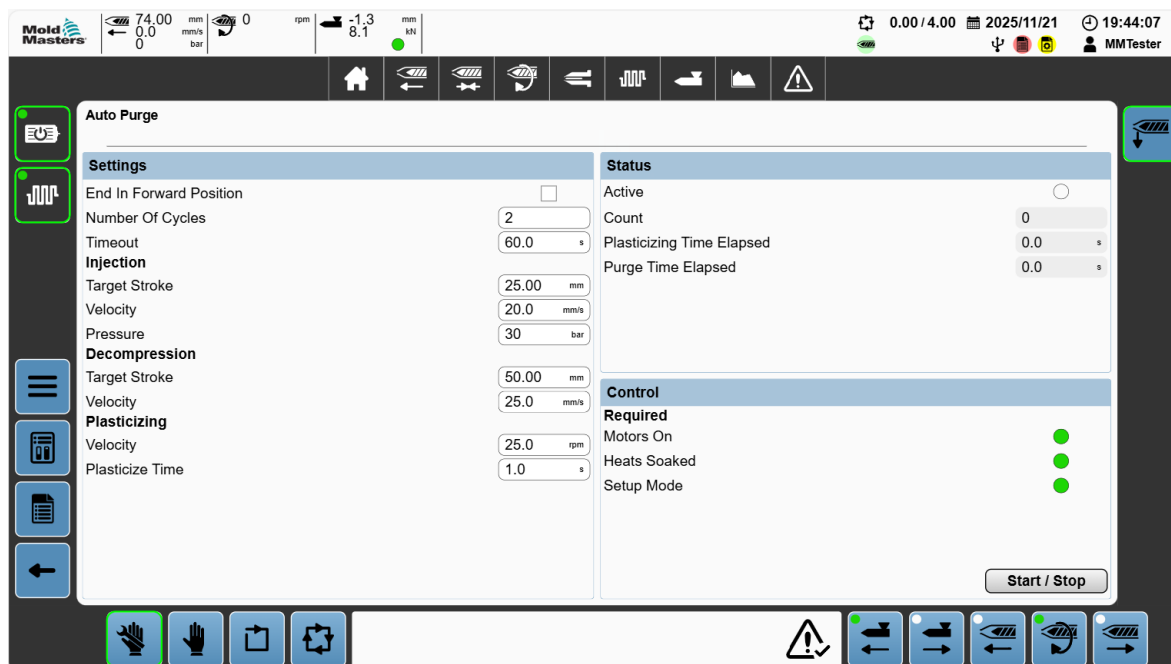

Figure 8-16 Auto purge screen

The Auto Purge cycle starts by injecting to the Injection Target Stroke at the set Velocity and Pressure. The screw then retracts to the Decompression Target Stroke at the set Velocity and proceeds to turn the screw at the set Plasticizing Velocity for the Plasticize Time. This constitutes one complete Auto Purge cycle.

Table 8-25 Status Panel	
Field	Description
Active	Green - If the auto purge is active, the LED will be green Off - If the auto purge is not active, the LED will be off
Count	Count of current auto purge cycles completed
Plasticizing Time Elapsed	Elapsed plasticizing time of current purge cycle
Purge Time Elapsed	Current elapsed time for auto purge

The maximum Target Strokes are the maximum plasticizing stroke and the maximum velocities are the maximum velocities for the associated movements, except the injection velocity, which has a maximum of the purge velocity limit.

Table 8-26 Control Panel	
Field/Button	Description
Required	
Motors On	Green - If the motors are enabled, the LED will be green Off - If the motors are disabled, the LED will be off
End In Forward Position	Auto purge completes with the injection screw forward in the purged position Click the check box to enable End In Forward Position
Number of Cycles	Number of purge cycles to complete during auto purge
Timeout	Maximum total auto purge time limit Values: Any positive value in s
Injection	
Target Stroke	Purge-cycle injection-target stroke / purge stop position.
Velocity	Purge-cycle decompression velocity
Pressure	Purge-cycle injection-pressure limit
Decompression	
Target Stroke	Target stroke of purge cycle decompression
Velocity	Purge-cycle decompression velocity
Plasticizing	
Velocity	Purge-cycle plasticizing velocity
Plasticizing time	Purge-cycle plasticizing time Values: Any positive value in seconds
Heats Soaked	Green - When the barrel heats are at temperature and soaked, the LED will be green Off - When the barrel heats are not at temperature and soaked, the LED will be off
Setup Mode	Green - when in setup operating mode, the LED will be green Off - when not in setup operating mode, the LED will be off
Start/Stop button	Tap this button to start or stop the auto-purge

8.8 Carriage (DC Motor)

Tap the following buttons in the order shown to go to the Carriage screen.

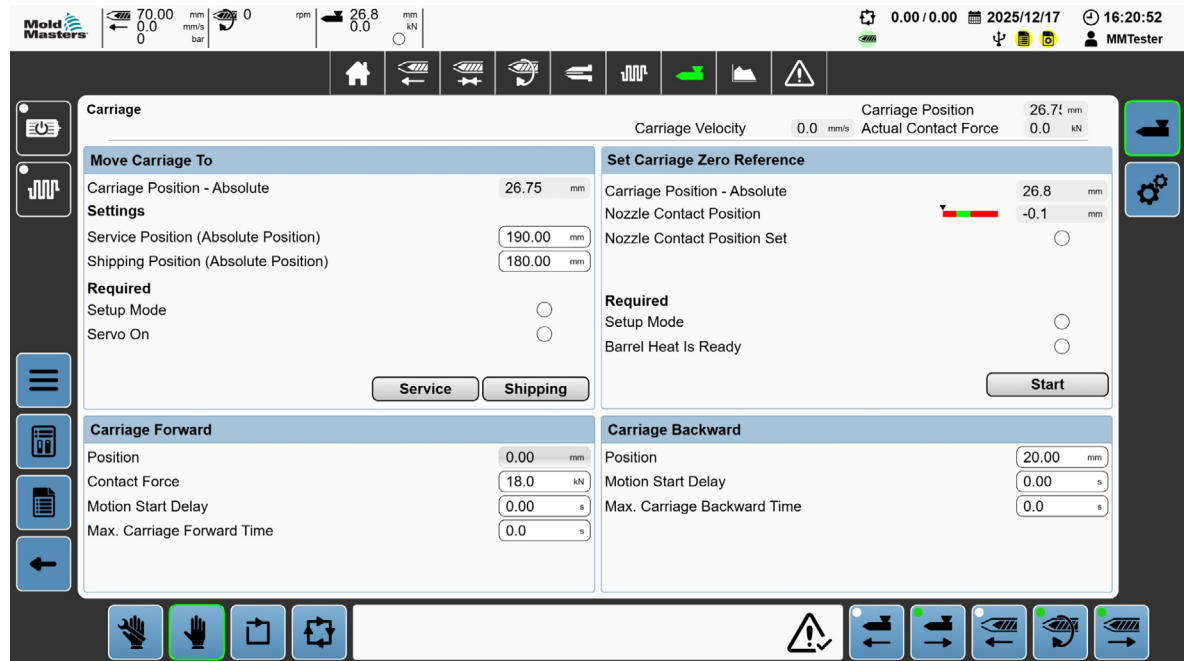

Figure 8-17 Carriage screen

Table 8-27 Move Carriage To Panel	
Field	Description
Carriage Position- Absolute	The true position of the carriage with respect to the full mechanical stroke. The standard Carriage Position is the Carriage Position – Absolute with the Nozzle Contact Position offset subtracted.
Settings	
Service Position (Absolute Position)	The ideal carriage position for sprue contact.
Shipping Position (Absolute Position)	The carriage position where the carriage can be locked into place for shipping.
Required	
Setup Mode	The machine needs to be in setup mode to activate the carriage motion to the service or shipping positions.
Servo On	The machine motors need to be turned on to activate the carriage motion to the service or shipping positions.

Table 8-27 Move Carriage To Panel	
Field	Description
Service	Move the carriage to the service position.
Shipping	Move the carriage to the shipping position.

Table 8-28 Set Carriage Zero Reference	
Field	Description
Carriage Position - Absolute	The true position of the carriage with respect to the full mechanical stroke. The standard Carriage Position is the Carriage Position – Absolute with the Nozzle Contact Position offset subtracted.
Nozzle Contact Position	Carriage absolute position at which the carriage nozzle makes contact with the mold sprue bushing.
Nozzle Contact Position Set	LED is green if contact position has successfully been set.
Required	
Setup Mode	The machine needs to be in setup mode to activate the carriage motion to the service or shipping positions.
Barrel Heat Is Ready	The barrel heating needs to be turned on and soaked to start the carriage motion to find the mold sprue contact position.
Start	Start the routine to find the mold sprue height. Carriage moves to a start position then travels forward until the carriage spring compression is detected.

Table 8-29 Carriage Forward Panel	
Field	Description
Position	Carriage forward position—permanently set to 0.0 mm.
Contact Force	Target carriage contact force against mold sprue bushing.
Reduced Contact Force With Mold Open	The contact force will be reduced when the mold opens. Tap the checkbox to enable and enter the desired contact force value in kN.
Motion Start Delay	Delay time before starting the carriage forward motion
Max. Carriage Forward Time	Maximum allowed time to move the carriage forward in automatic mode. Setting this to 0.0 seconds disables the time limit.

Table 8-30 Carriage Backward Panel	
Field	Description
Position	Carriage back position. The carriage will stop at the position during manual motion. To retract past this position once it is reached, release the carriage backward push button and then press it again.
Motion Start Delay	Delay time before starting the carriage backward motion
Max. Carriage Backward Time	Maximum allowed time to move the carriage back in automatic mode. Setting this to 0.0 seconds disables the time limit.

8.9 Pneumatic Controls

8.9.1 Valve Gates

Tap the following buttons in the order shown to go to the Valve Gates screen.

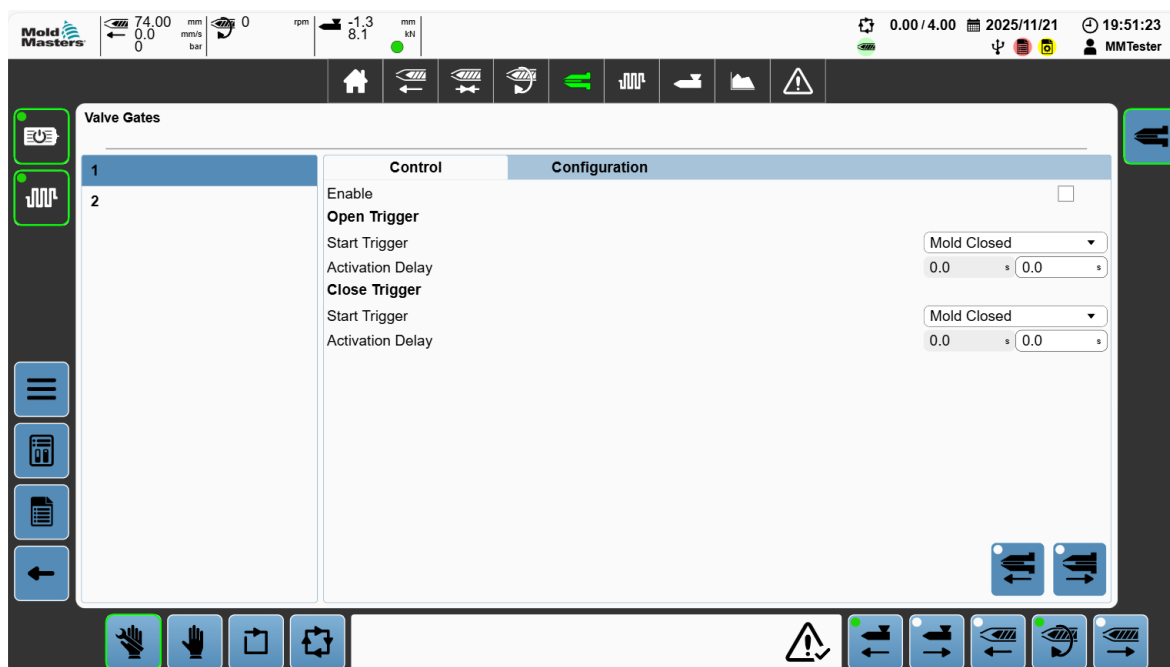
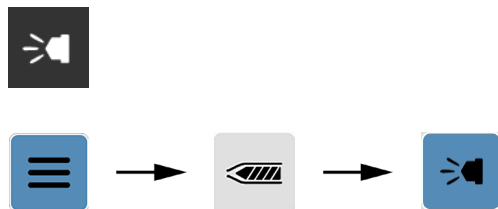

Figure 8-18 Valve gates screen

Table 8-31 Control Tab	
Field/Buttons	Description
Enable	Tap the check box to enable the valve gate.
Open Trigger	
Start Trigger	Trigger signal to start valve-gate open action See section <i>Table 9-2 Conditions Detailed-Dialog Box</i> on page 9-9 for more information.
Activation Delay	Delay time between activation trigger and start of motion Values: Any positive value in seconds
Close Trigger	
Start Trigger	Trigger signal to start valve-gate open action See section <i>Table 9-2 Conditions Detailed-Dialog Box</i> on page 9-9 for more information.

Table 8-31 Control Tab	
Field/Buttons	Description
Activation Delay	Delay time between activation trigger and start of motion Values: Any positive value in seconds

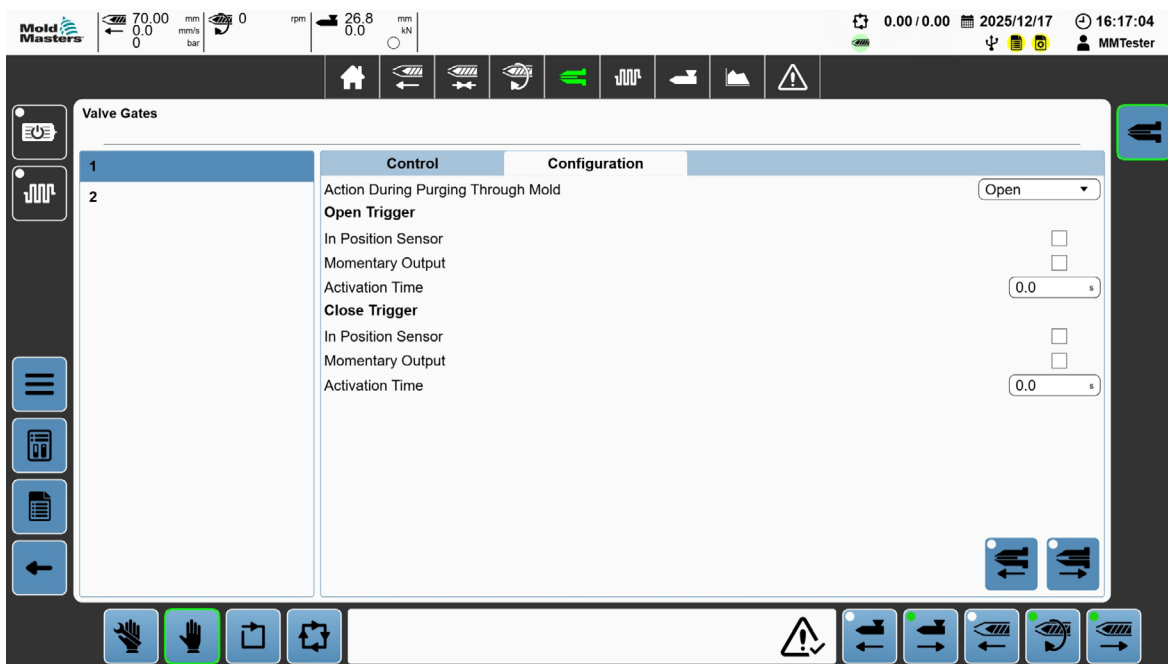



Figure 8-32 Configuration tab

Table 8-33 Configuration Tab	
Field/Buttons	Description
Action During Purging Through Open Mold	Open: The selected valve gate will move to the open position while purging through the mold is active. The valve gate will move to the close position once purging is stopped. Close: The selected valve gate will move to the close position while purging through the mold is active, and remain closed when purging is stopped. None: The valve gate will not be activated during purging through the mold.
Open Trigger	
In Position Sensor	Tap the check box to enable position sensors to determine if the valve gate is at the end position.
Momentary Output	Tap this check box to maintain the motion output signal high after motion finishes.
Activation Time	Set time for motion Values: Any positive value in seconds
Close Trigger	

Table 8-33 Configuration Tab	
Field/Buttons	Description
Action During Purging Through Open Mold	<p>Open: The selected valve gate will move to the open position while purging through the mold is active. The valve gate will move to the close position once purging is stopped.</p> <p>Close: The selected valve gate will move to the close position while purging through the mold is active, and remain closed when purging is stopped.</p> <p>None: The valve gate will not be activated during purging through the mold.</p>
In Position Sensor	Tap the check box to enable position sensors to determine if the valve gate is at the end position.
Momentary Output	<p>Tap this check box to maintain the motion output signal high after motion finishes.</p> <p>The output stays active until opposite motion is activated.</p>
Activation Time	<p>Set time for motion</p> <p>Values: Any positive value in seconds</p>
	<p>Open Valve Gate button</p> <p>Tap this button to manually open the valve gate.</p>
	<p>Close Valve Gate button</p> <p>Tap this button to manually close the valve gate.</p>

8.10 Barrel Heats

Tap the following buttons in the order shown to go to the Barrel Heats screen.

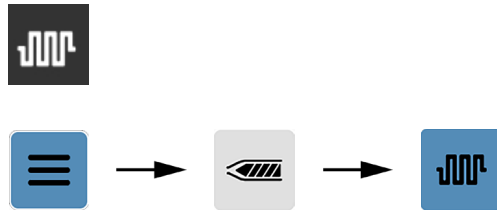

8.10.1 Barrel Heats

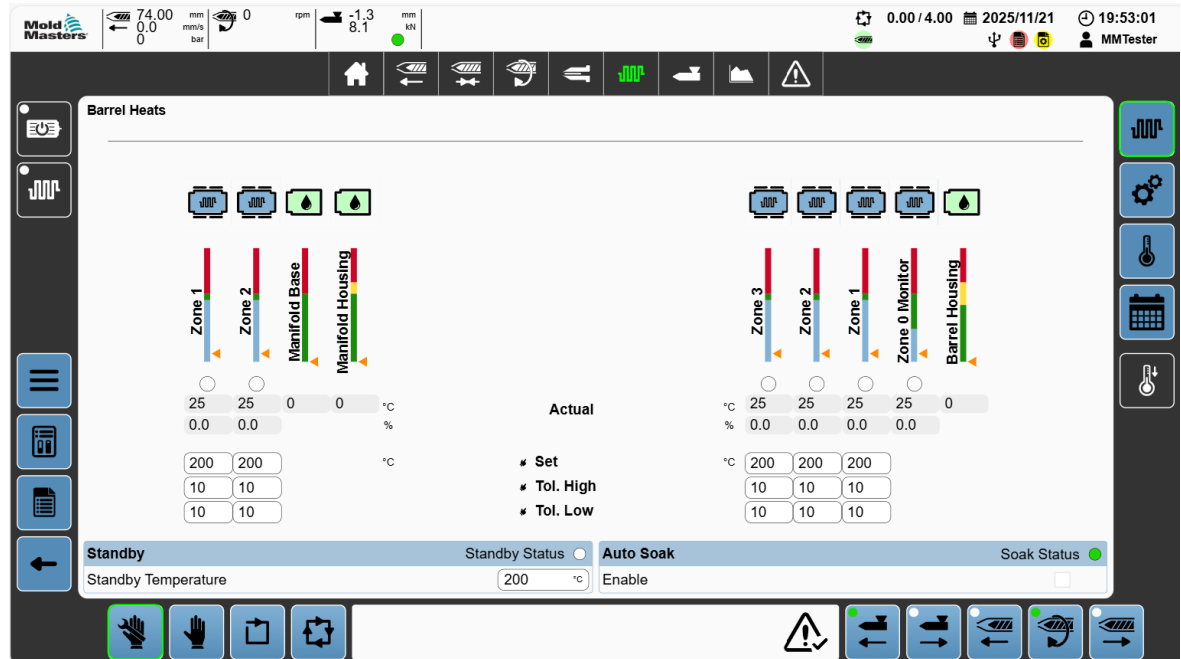



Figure 8-19 Barrel heats screen

Table 8-34 Barrel Heats Screen	
Field/Buttons	Description
<p>Soak Time</p> <p>0.0 min / 0.1 min</p>	<p>Soak Time (actual value)</p> <p>Soak time (actual value) / Soak Time (set value)</p> <p>The Soak Time display is not shown when the soaking of zones is complete.</p>
<p>Zone Type</p>	<p>When the zone is below the set temperature minus the low tolerance, the zone icon is colored blue.</p> <p>When the zone is within the tolerance of the set temperature, the zone icon is colored green.</p> <p>When the zone is above the set temperature plus the high tolerance, the zone icon is colored red.</p>
	<p>Distribution Zone type</p>

Table 8-34 Barrel Heats Screen	
Field/Buttons	Description
	Barrel Housing Zone type
	<p>Zone Temperature Bars</p> <p>Each zone has a temperature scale that shows the current location on the scale using an arrow pointer to the right of the scale and the name of the zone to the left of the scale</p> <p>The green section of the scale is the set temperature and tolerance band.</p> <p>The red section of the scale is the over-temperature band (above the tolerance band). The blue section of the scale is the under-temperature band (below the tolerance band).</p>
	Actual temperatures of the zones
	<p>Temperature Set Points</p> <p>Values: 0 to 350</p> <p>Tap a temperature to edit the temperature.</p>
	<p>High tolerances of the set temperatures</p> <p>Values: Values: 0 to 50</p> <p>Tap a temperature to edit the temperature.</p>
	<p>Low tolerances of set temperatures</p> <p>Values: Values: 0 to 50</p> <p>Tap a temperature to edit the temperature.</p>
Standby Panel	
	<p>Standby Status</p> <p>Green - LED is green when the standby is active</p> <p>Off - LED is off when the standby is inactive</p>
Standby Temperature	<p>Set temperature for standby mode (reduced temperature when injection is idle for an extended period of time)</p> <p>Values: Any positive value in °C</p> <p>Tap this field to edit the temperature.</p>
Auto Soak Panel	
	<p>Soak Status</p> <p>When barrel heats are soaked; that is, all barrel temperature zones are within the set point tolerance for the soak time LED is green</p>

Table 8-34 Barrel Heats Screen	
Field/Buttons	Description
Enable	Click the check box to enable the Auto-Soak function when checked Once the soak timer completes, Auto Soak rotates the screw at low torque and low speed for a set number of degrees. If the rotation is successful, the soak is completed. If the rotation is unsuccessful, a further soak time is waited and then Auto Soak can be re- attempted
	<p>Activate Standby button</p> <p>Values: White (when standby is off), green (when standby is on)</p> <p>Tap this button to change the standby to on or off.</p>

8.10.2 Barrel Heats Configuration



Figure 8-20 Barrel heats configuration screen with the Settings tab selected

Table 8-35 Settings Screen	
Field	Description
Maximum Zone Set Point	Maximum allowed actual temperature above the set temperature before the heats are disabled. Values: 0 °C to 350 °C
Maximum Zone High Tolerance	Maximum high-tolerance setting Values: Any negative value up to maximum positive value in °C
Auto Soak	
Enable	Click the check box to enable the Auto-Soak function when checked Once the soak timer completes, Auto Soak rotates the screw at low torque and low speed for a set number of degrees. If the rotation is successful, the soak is completed. If the rotation is unsuccessful, a further soak time is waited and then Auto Soak can be re- attempted
Soak Time	Set soak time Values: 0 min to 60 min
Soak Retry Delay	Set soak retry delay time to delay screw movements before next attempt Values: 0 min to 60 min

Table 8-35 Settings Screen	
Field	Description
Timeout	Maximum time for Auto-Soak to complete screw stroke rotation Values: 0 min to 60 min
Max Attempts	Maximum number of attempts at Auto Soak Values: 0 to 255
Screw Stroke	Number of degrees the screw must rotate during Auto-Soak Values: Any negative value up to maximum positive value in degree
Screw Velocity	Rotational velocity for the screw during Auto- Soak Values: 0 rpm to 500 rpm
Screw Force	Maximum screw force allowed during Auto- Soak rotation attempts Values: 0 N.m to 15 N.m
Standby	
Disable Automatic Standby	Click check box to display the heat automatic standby behaviour
Standby Temperature	Set temperature for standby mode (reduced temperature when injection is idle for an extended period of time) Values: Any positive value in °C
Injection Idle Time	Maximum-allowed idle time for injection (time without injection or purge) with heats on before standby is activated Values: 0 min to 120 min To disable this feature, set to 0.
Shutdown Time	Maximum allowed idle time for injection (time without injection or purge) in standby before heats are deactivated Values: 0 min to 120 min
Monitoring	
Minimum Temperature Increase	Minimum increase in temperature that must be recorded for an active heat zone within the time limit Values: Any positive value in °C
Maximum Temperature-Increase Time	Maximum time to see the minimum increase in temperature for an active heat zone Values: 0 s to 2,147,484 s

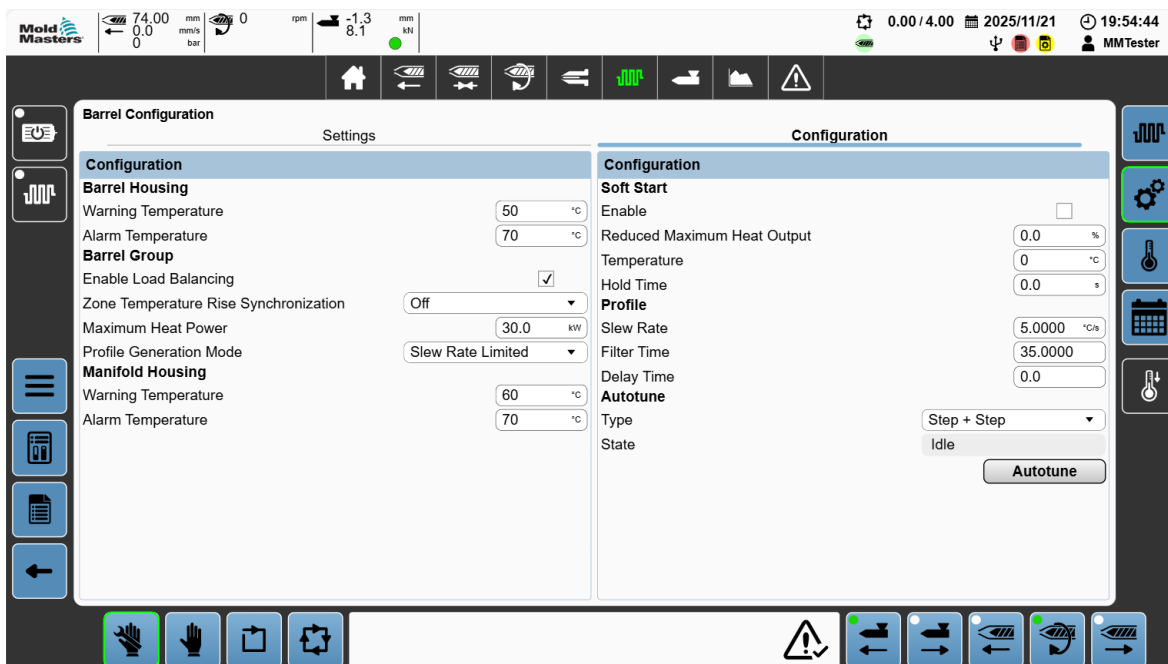



Figure 8-21 Barrel heats configuration screen with the Configuration tab selected

Table 8-36 Configuration Screen	
Field/Button	Description
Barrel Housing	
Warning Temperature	Barrel housing temperature at which the warning alarm is generated. The alarm is for information purposes only. Value: 0 °C to 1000 °C
Alarm Temperature	Maximum allowed temperature of the barrel housing If the barrel housing reaches this temperature, an alarm is triggered and the heats are turned off. Value: 0 °C to 1000 °C
Barrel Group	
Enable Load Balancing	Click the check box to enable the barrel-group load balancing which coordinates the activation of the grouped barrel zones in such a way as to minimize power peaks

Table 8-36 Configuration Screen	
Field/Button	Description
Zone Temperature-Rise Synchronization	<p>Determines how the barrel-heat group profile settings used to synchronize all the zones within the group are determined</p> <p>Values:</p> <ul style="list-style-type: none"> • Off - The profile synchronization is disabled. • Automatic - The profile parameters for synchronizing the profiles are automatically identified by the referenced controller. • User Defined - The profile parameters for synchronizing the profiles are specified by the user.
Maximum Heat Power	<p>Defines the maximum power available to the heating group</p> <p>Values: 0 kW to 100kW</p> <p>If the combined maximum power draw of the group zones exceeds the available group maximum heat power, the group controller will schedule the zone heating outputs to limit the maximum draw of the active heating zones.</p>
Profile Generation Mode	<p>Configures the set point profile generation for all zones in the barrel group</p> <p>Values:</p> <ul style="list-style-type: none"> • Time Optimized - Uses profile generation and feed-forward control to reach the desired temperature as quickly as possible • Slew Rate Limited - Uses profile generation and feed-forward control to reach the desired temperature with the specified profile without exceeding a certain temperature slew rate
Manifold Housing	
Warning Temperature	<p>Shooting Pot housing temperature at which the warning alarm is generated. The alarm is for information purposes only.</p> <p>Value: 0 C to 1000 C</p>
Alarm Temperature	<p>Maximum allowed temperature of the Shooting Pot housing</p> <p>If the Shooting Pot housing reaches this temperature, an alarm is triggered and the heats are turned off.</p> <p>Value: 0 C to 1000 C</p>
Soft Start	

Table 8-36 Configuration Screen	
Field/Button	Description
Enable	Enables soft start for the barrel group Soft start temporarily reduces the maximum heat output (output active time for pulse width modulation)
Reduced Maximum Heat Output	Reduced maximum-heat output during soft start Overrides the maximum-heat output settings of the individual zone for all zones in the group
Temperature	Target temperature for soft start Values: Any positive value up to 120 Soft start is active until all zones in the group reach the target temperature and waits the hold time.
Hold Time	Time to hold the temperature for temp PID tuning
Profile	
Slew Rate	Limitation of the slope of the temperature signal (°C/s) Select a number so that the system can follow the slope.
Filter Time	Filter time for the generated signal temperature signal(s) This parameter rounds the generated profile at the beginning and end.
Delay Time	Delay time for the generated signal temperature signal(s) Values: Any positive value
Auto-Tune	
Type	Type of Auto-Tune <ul style="list-style-type: none"> • Step- Tune to a single set temperature • Step + Step- Tune to a set temperature, then start a second tune to a higher set temperature • Step + Oscillation- Tune to a set temperature, then start tuning by oscillating the actual temperature around the set temperature from the step tuning

Table 8-36 Configuration Screen	
Field/Button	Description
State	<p>Current State of Auto-Tune Values:</p> <ul style="list-style-type: none"> • Idle • Initializing • System Check • Delay Time • PID • Prediction • In Set point • Done • Error • Aborted <p>For auto-tuning to commence, the temperatures must be stable and at least 20 degrees lower than the tuning temperature set point.</p>
	<p>Auto-Tune button</p> <p>Tap this button to start the auto-tune</p>

8.11 Incremental Startup

Tap the following buttons in the order shown to go to the Incremental Startup screen.

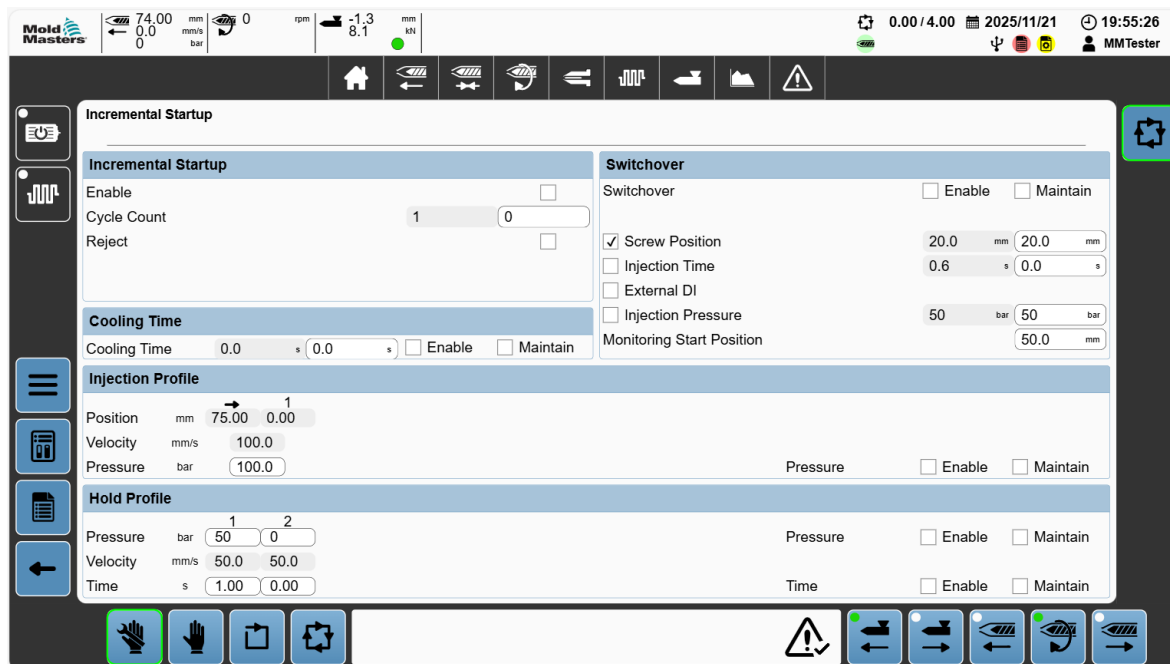

Figure 8-22 Incremental startup screen

The Incremental Startup (ISU) option provides an easy to use way for you to transition from special-processing-parameter settings, used when first starting to run, to the standard processing parameter settings used during production. The number of cycles that the ISU lasts is set on the HMI. While ISU is active, the selected process variables will be adjusted in equal steps each startup cycle, going from the initial startup values at the beginning and finishing at the normal operation values for the process variables by the end of the ISU cycles. The ISU can also be configured, on a variable by variable basis, to maintain the ISU values during the ISU cycles without stepping, returning to standard processing values once the ISU cycles are complete.

The Incremental Startup program can be enabled or disabled and manually started or stopped using the HMI. When enabled, the Incremental Startup program will run when automatic cycling is initiated after machine power is reset or when automatic cycling has been suspended for longer than a set period of time.

Table 8-37 Incremental Startup Panel	
Field	Description
Enable	Click this check box to enable incremental startup cycles.
Cycle Count	Numeric output field (actual value; read only): Count of the actual incremental startup cycles Numeric input field Tap this field to set the number of machine cycles to run the Incremental Startup Values: 0 to 100
Reject	Click this check box to mark all incremental startup cycles as reject cycles.

Table 8-38 Cooling Time Panel	
Field	Description
Cooling Time	Numeric Output (actual value, read only): Cooling time of current cycle Numeric Input: Tap this field to set the cooling time for incremental startup cycles Values: Any negative value up to maximum positive value in seconds Click the check box to enable "Enable" Click the check box to enable "Maintain"

Table 8-39 Switchover Panel	
Field	Description
Switchover	Enable check box - Click this check box to use the incremental startup values during incremental startup cycles. Maintain check box - Click this check box to maintain incremental-startup set points without modification over the incremental startup cycles.
Screw Position	Checkbox: Click this check box to enable switchover using the screw position. Numeric Output (actual value, read only): Actual screw position at switchover Values: Any negative value up to maximum positive value in mm Numeric Input: Click this field to set the screw position for switchover.

Table 8-39 Switchover Panel	
Field	Description
Injection Time	<p>Check box: Click this check box to enable switchover using injection time</p> <p>Numeric output (actual value, read only): Injection time at switchover</p> <p>Values: Any negative value up to maximum positive value in mm</p> <p>Numeric Input: Tap this field to set the injection time for switchover.</p>
External DI	<p>Click this check box to enable switchover using the digital input signal.</p>
Injection Pressure	<p>Check box: Click this check box to enable switchover using injection pressure</p> <p>Numeric Output (actual value, read only): Injection pressure at switchover</p> <p>Values: Any positive value</p> <p>Numeric Input: Click this field to set the injection pressure for switchover.</p>
Monitoring Start Position	<p>Tap this field to enter the injection position at which to start monitoring pressure for switchover</p> <p>Values: Any negative value up to maximum positive value in seconds</p>

The Incremental Startup Cycles use the same number of injection profile stages as set on the standard Injection screen.

Table 8-40 Injection Profile Panel	
Field	Description
Position	<p>Injection-stage end positions</p> <p>Values: Any positive value up to the stroke value of the previous stage</p> <p>Position settings are from the standard injection profile and are not adjusted during incremental startup cycles</p>
Velocity	<p>Injection-velocity set points for each stage</p> <p>Values: Any positive value up to the maximum injection velocity Velocity settings are from the standard injection profile and are not adjusted during incremental startup cycles</p>
Pressure	<p>Injection pressure limit for each stage</p> <p>Values: 0 bar to 1280 bar</p> <p>Click the check box to enable "Enable"</p> <p>Click the check box to enable "Maintain"</p>

The Incremental Startup Cycle uses the same number of hold profile stages as set on the standard Hold screen.

Table 8-41 Hold Profile Panel	
Field	Description
Pressure	<p>Numeric input fields: Hold pressure profile for incremental startup cycles</p> <p>Values: 0 bar to 1280 bar</p> <p>Enable check box - Tap this check box to use the pressure settings in the incremental startup cycles during incremental startup. Unchecked: The pressure settings in the standard hold profile are used during incremental startup.</p> <p>Maintain check box - Tap this check box to apply the incremental startup pressure profile as set through the entire incremental startup cycles when maintained. Unchecked: The incremental startup pressure profile is not incrementally changed each cycle of the incremental startup.</p>
Velocity	<p>Numeric output fields (actual value, read only): Hold-velocity-limit set points for each stage</p> <p>The velocity settings are from the standard hold profile and are not adjusted during incremental startup cycles.</p>
Time	<p>Numeric input fields: Hold time for each stage</p> <p>Values: Any negative value up to maximum positive value in seconds</p> <p>Enable check box - Tap this check box to use the hold time settings in the incremental startup cycles during incremental startup. Unchecked: The hold time settings in the standard hold profile are used during incremental startup.</p> <p>Maintain check box - Tap this check box to apply the incremental- startup hold-time profile as set throughout all the incremental startup cycles. Unchecked: The incremental-startup hold-time profile is not incrementally changed each cycle of the incremental startup.</p>

8.12 RJG Interface

Tap the following buttons in the order shown to go to the RJG screen.

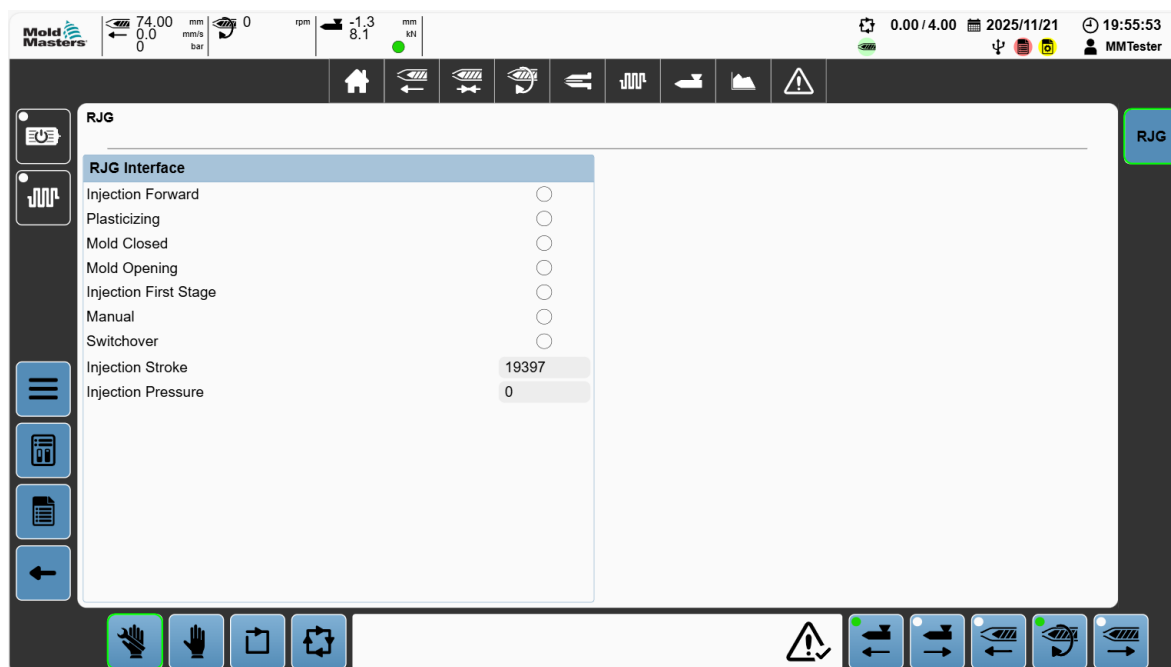

Figure 8-23 RJG interface screen

Table 8-42 RJG Interface Panel	
Field	Description
Injection Forward	Red - If the LED is red, the injection is active. Off - If the LED is off, the injection is inactive.
Plasticizing	Red - If the LED is red, the plasticizing is active. Off - If the LED is off, the plasticizing is inactive.
Mold Closed	Red - If the LED is red, the mold is closed. Off - If the LED is off, the mold is open. From the Euromap 67 interface
Mold Opening	Red - If the LED is red, the mold is opened. Off - If the LED is off, the mold is closed. From the Euromap 67 interface
Injection First Stage	Red - If the LED is red, the injection boost is active. Off - If the LED is off, the injection boost is inactive.
Manual	Red - If the LED is red, the E-Multi is in manual mode. Off - If the LED is off, the E-Multi is not in manual mode.

Table 8-42 RJG Interface Panel	
Field	Description
Switchover	<p>Red -If the LED is red, there is an external switchover from RJG.</p> <p>Off - If the LED is off, there is no external switchover from RJG.</p>
Injection Stroke	<p>E-Multi injection stroke</p> <p>Sample values:</p> <ul style="list-style-type: none"> • 0 Analog Counts = Injection at 0 mm • 32767 Analog Counts = Maximum injection stroke <p>B&R analog cards use 0 counts for 0 output and 32767 counts for maximum output</p>
Injection Pressure	<p>E-Multi injection pressure</p> <p>Sample values:</p> <ul style="list-style-type: none"> • 0 Analog Counts = Injection pressure at 0 bar • 32767 Analog Counts = Maximum injection pressure

8.13 Sequence

Tap the following buttons in the order shown to go to the Sequence Viewer screen.



8.13.1 Sequence Viewer Screen

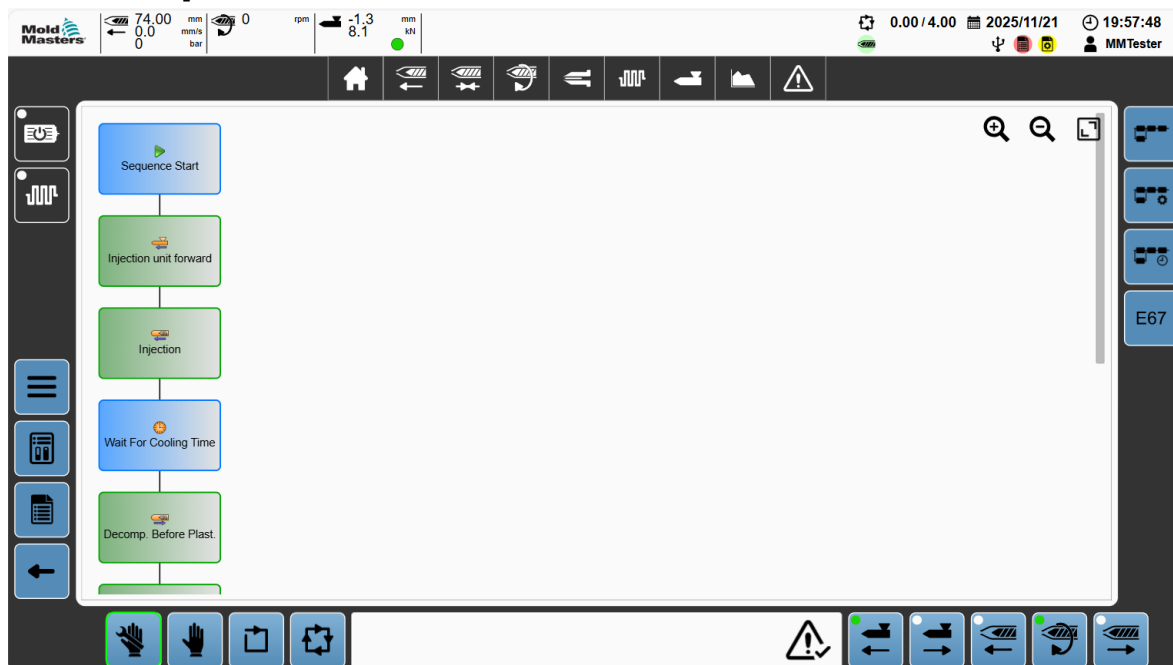



Figure 8-24 Sequence viewer screen

Table 8-43 Sequence Viewer Screen	
Field/Button	Description
	<p>Display of the active sequence</p> <p>The active steps are highlighted during automatic mode cycling.</p>
	<p>Zoom in button</p> <p>Tap this button to zoom in on the sequence.</p>

Table 8-43 Sequence Viewer Screen	
Field/Button	Description
	Zoom out button Tap this button to zoom out from the sequence.
	Reset Zoom button Tap this button to restore the sequence to the default zoom level.

8.13.2 Sequence Editor Screen

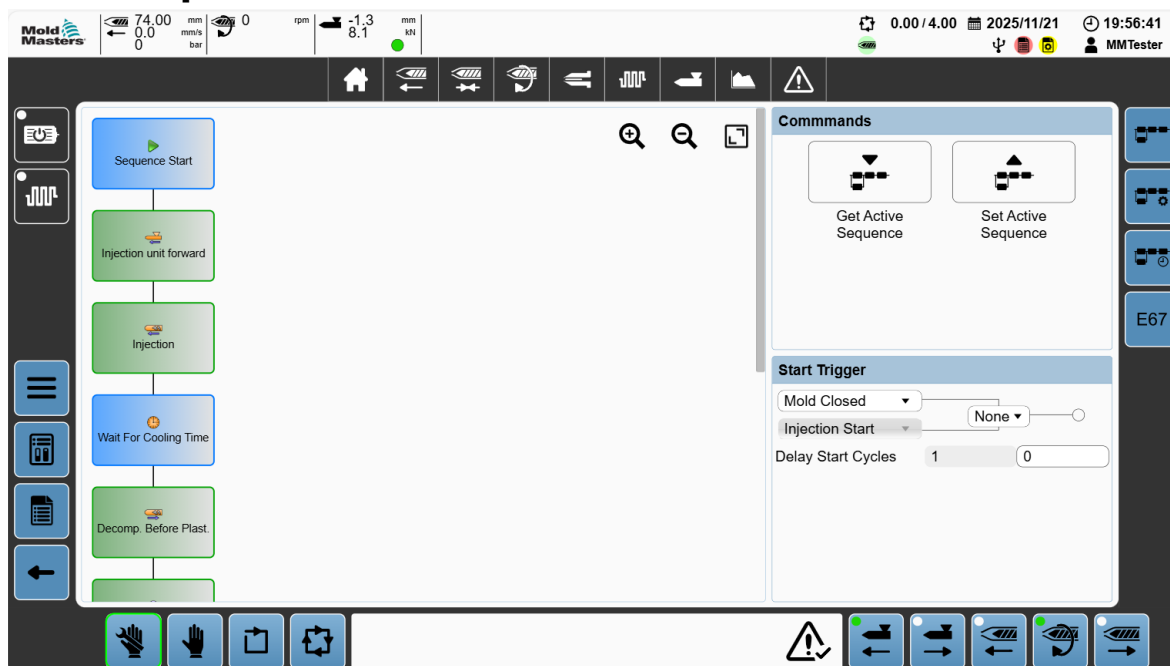
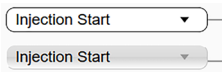



Figure 8-25 Sequence editor screen

For more information about the left panel of the Sequence Editor screen, see *section 8.13.1 Sequence Viewer Screen on page 8-54*.

Table 8-44 Commands Panel	
Button	Description
	<p>Get Active Sequence button</p> <p>Tap this button to load the active sequence currently running into the editor.</p> <p>Any unsaved changes to the sequence in the editor will be lost.</p>
	<p>Set Active Sequence button</p> <p>Tap this button to set the sequence currently in the editor as the active sequence.</p> <p>Changes made to the sequence in the editor are not live and only go into effect after the Set active sequence button is pressed.</p> <p>The Set active sequence button is only available while the E-Multi is not in automatic mode.</p>

Table 8-45 Start Trigger Panel	
Field/Button	Description
	<p>E-Multi auto cycle start triggers has the following dropdown options:</p> <ul style="list-style-type: none"> • Injection Start • Mold Closed • Ejector 1 Back • Ejector 1 Forward • Core 1 In Position 1 • Core 2 In Position 2 • IMM Screw Position • Remote Trigger • No Trigger <p>Two triggers are available, but the second trigger is optional.</p> <p>The E-Multi Mini injection sequence starts when the start condition changes from false to true.</p>
	<p>Logic selection for the injection start triggers</p> <p>AND - Both the start trigger conditions must be satisfied to start injection.</p> <p>OR - Injection starts when either of the start trigger conditions are satisfied.</p> <p>None - When the first start trigger condition is used (second condition cannot be set).</p>
	<p>Delay Start Cycles</p> <p>Actual delayed cycle count is shown in the grayed-out field.</p> <p>Delays the start of the first cycle of the E-Multi Mini until the start trigger is observed the number of times set here.</p> <p>Values: 0 and 255</p>

8.13.2.1 Modifying the Sequence

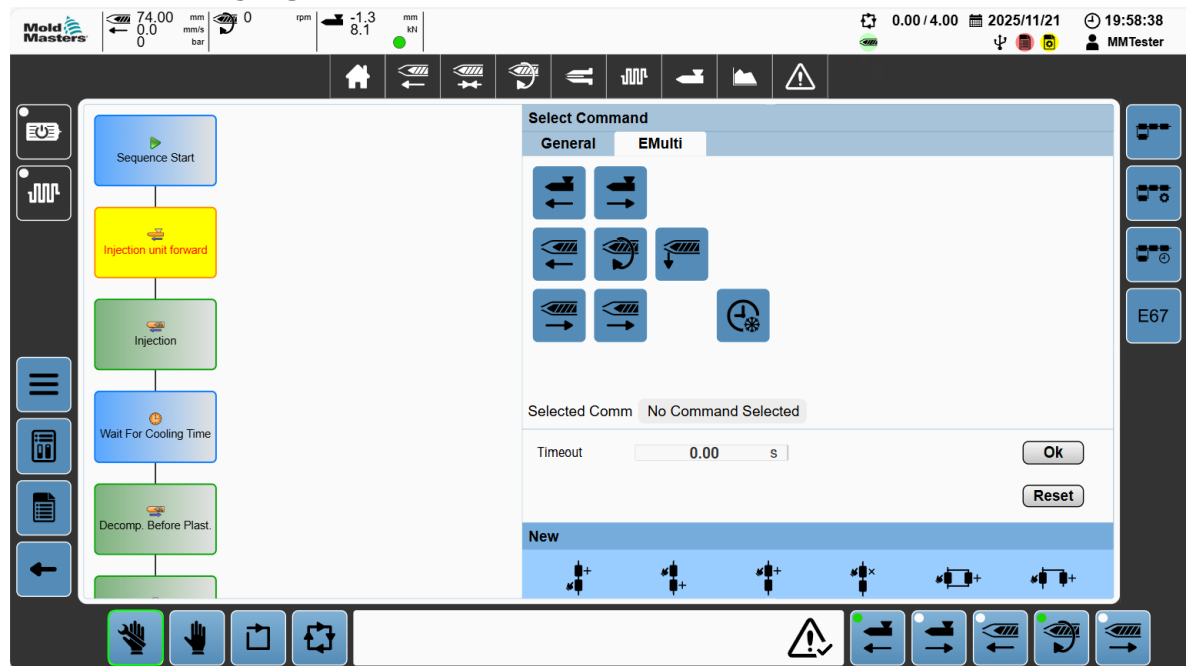







Figure 8-26 Sequence editor screen with Select command panel

Table 8-46 Select Command Panel	
Field/Button	Description
	Selection of available sequence step types
Selected Command <input type="text" value="Carriage Forward"/>	Selected Command Name of the selected command step

Table 8-46 Select Command Panel	
Field/Button	Description
Timeout	<p>Any additional parameters for the selected step can be entered or modified here.</p> <p>The Timeout parameter specifies the time limit for the execution of the step. A timeout setting of 0.0 seconds disables the timeout feature.</p> <p>Values: 0 s to 1000 s</p> <p>Ok button</p> <p>Tap the OK button to input the entered parameter settings for the selected step</p> <p>Reset button</p> <p>Tap the Reset button to reset the parameter settings to their original, unmodified values.</p>
	<p>Add new step before selected step</p> <p>Tap this button to add the new step from the Selected Command before the selected step in the sequence.</p>
	<p>Add new step after selected step</p> <p>Tap this button to add the new step from the Selected Command after the selected step in the sequence.</p>
	<p>Replace selected step with new step</p> <p>Tap this button to replace the selected step in the sequence with the new step from the Selected Command.</p>
	<p>Delete selected step in sequence</p> <p>Tap this button to delete the selected step in the sequence.</p>
	<p>Add closed branch with new step</p> <p>Tap this button to add a closed branch with the new step from the Selected Command parallel to the selected step in the sequence.</p>
	<p>Add open branch with new step</p> <p>Tap this button to add an open branch with the new step from the Selected Command parallel to the selected step in the sequence.</p>

8.13.2.2 Wait Points

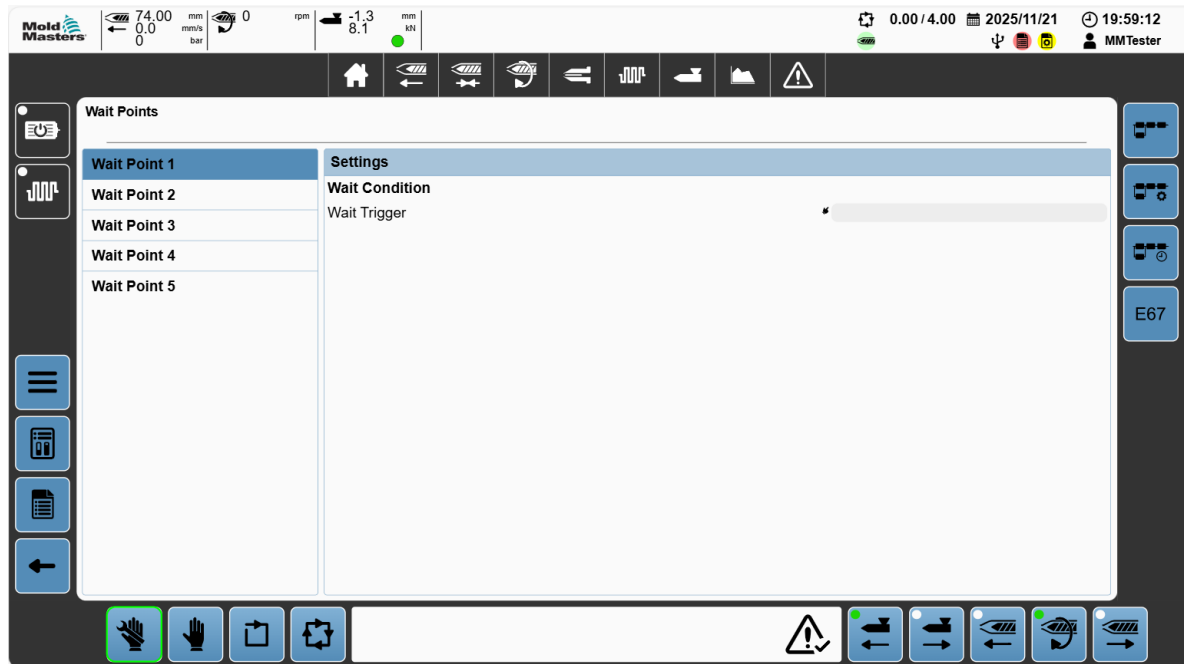
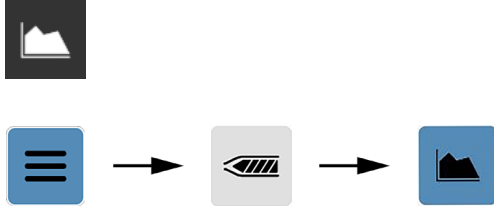

Figure 8-27 Sequence editor screen with Wait points setting panel

Table 8-47 Wait-Points Setting Panel	
Field/Button	Description
Wait Condition	
Wait Trigger	Press this field to open the conditions dialog box to select a wait trigger

8.14 Trace

Tap the following buttons in the order shown to go to the Graph screen.



8.14.1 Graph Screen

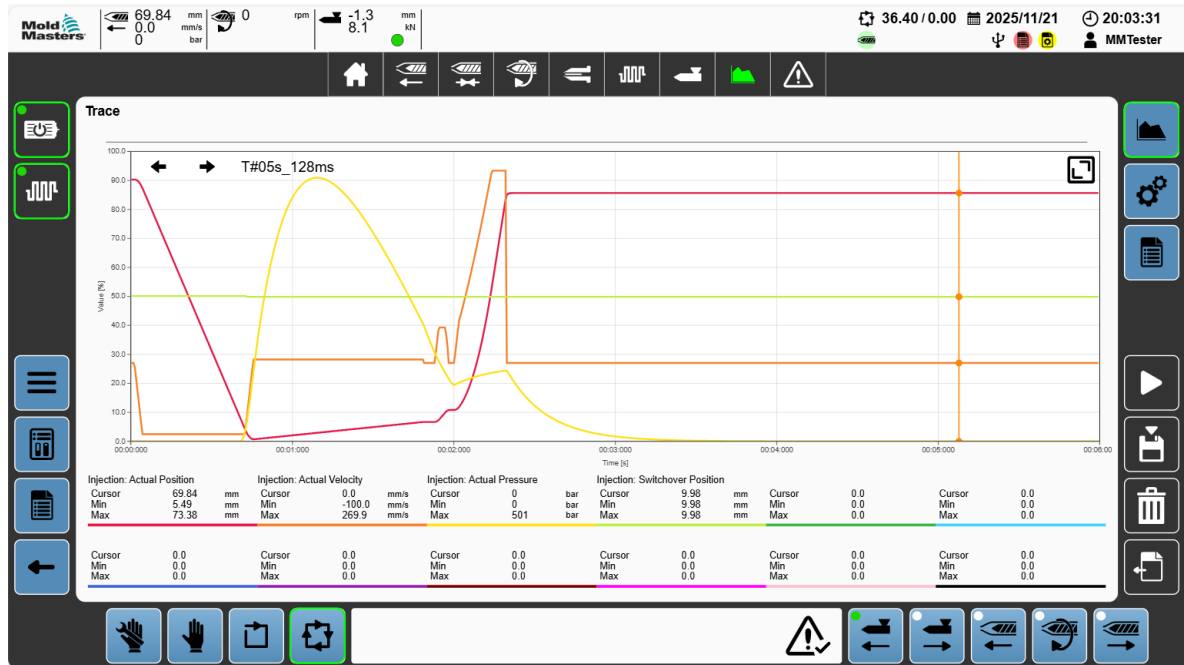

Figure 8-28 Graph screen



Table 8-48 Graph Screen	
Field/Button	Description
 	<p>Move Cursor</p> <p>Move the cursor one step left or right</p> <p>The cursor time stamp is displayed to the right of the buttons.</p>

Table 8-48 Graph Screen																	
Field/Button	Description																
	<p>Display Trace</p> <p>Y-axis: Percent</p> <p>X-axis: Time</p> <p>All percent values are scaled to be between 0 and 100.</p> <p>Pinch to zoom.</p> <p>You can drag the cursor to the required location. You can make fine adjustments with the Move Cursor buttons.</p>																
<table border="1"> <thead> <tr> <th colspan="2">Injection: Actual Position</th> <th colspan="2">Injection: Actual Velocity</th> </tr> </thead> <tbody> <tr> <td>Cursor</td> <td>75.4 mm</td> <td>Cursor</td> <td>0.0 mm/s</td> </tr> <tr> <td>Min</td> <td>16.1 mm</td> <td>Min</td> <td>0.0 mm/s</td> </tr> <tr> <td>Max</td> <td>75.4 mm</td> <td>Max</td> <td>268.3 mm/s</td> </tr> </tbody> </table>	Injection: Actual Position		Injection: Actual Velocity		Cursor	75.4 mm	Cursor	0.0 mm/s	Min	16.1 mm	Min	0.0 mm/s	Max	75.4 mm	Max	268.3 mm/s	<p>PV (Process Variable) Overview</p> <p>Displays the traced PV name, value at cursor, minimum/maximum values and the line colors of the traces.</p>
Injection: Actual Position		Injection: Actual Velocity															
Cursor	75.4 mm	Cursor	0.0 mm/s														
Min	16.1 mm	Min	0.0 mm/s														
Max	75.4 mm	Max	268.3 mm/s														
	<p>Autoscale button</p> <p>Automatically scales minimum and maximum scaling values of PV's</p> <p>Scale maximum = Max value + 0.1*max value</p> <p>Scale minimum = Min value - 0.1*min value</p> <p>Custom scaling can be set on the trace configuration screen</p>																
	<p>Start/Stop Button</p> <p>Tap this button to start recording the trace. Tap this button to stop recording the trace.</p>																
	<p>Save Button</p> <p>Tap this button to save trace data as a csv file. If a USB memory stick is plugged into the system, the trace data is saved to the USB memory stick. Otherwise, the trace is saved to the user data. The trace data can be exported from the user data screen.</p>																
	<p>Delete Button</p> <p>Tap this button to delete all the process variables</p>																
	<p>Export to USB Button</p> <p>Tap this button to export all the trace files to a USB.</p> <p>Note: All the files will be deleted from the system</p>																

8.14.2 Configuration Screen

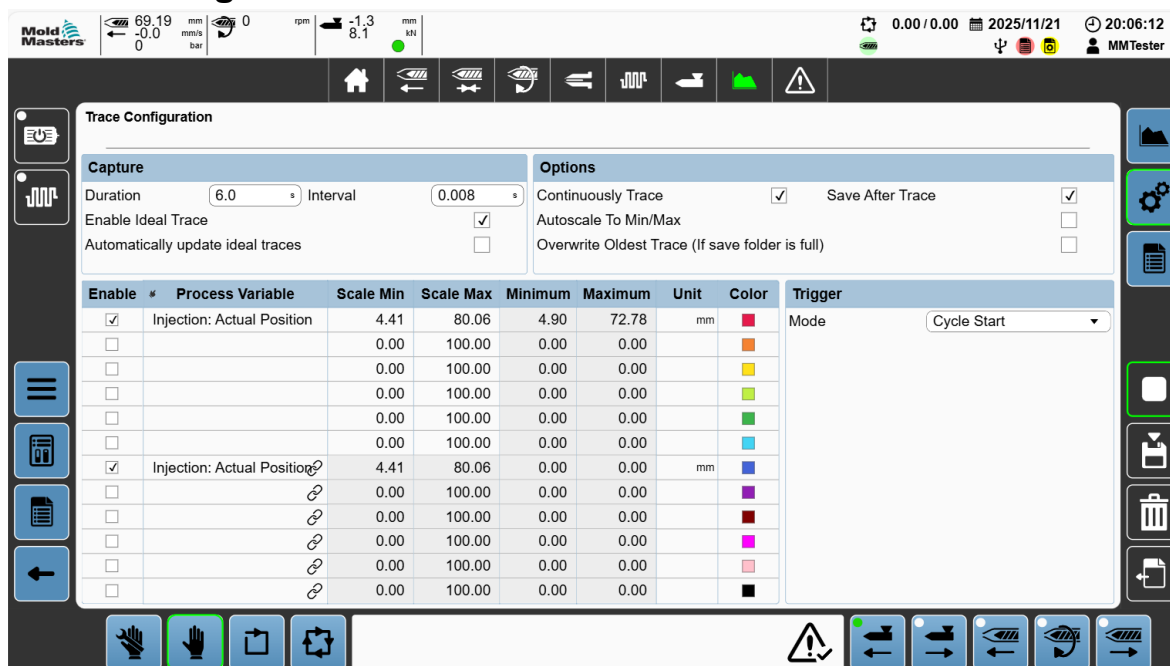

Figure 8-29 Configuration screen

Table 8-49 Capture Panel	
Field	Description
Duration	Total PV capture duration Values: 0 s to 4,294,967 s Changing the duration will adjust the Interval to the lowest possible interval
Interval	PV sampling time. Every interval the current values of the selected PV values are recorded Values: 0 s to 4,294,967 s Entered value will automatically be adjusted to a multiple of 0.008 s Changing the interval will adjust the Duration to the maximum time possible at that interval.
Enable Ideal Trace	Enabling Ideal trace converts process variables 6 to 10 into ideal traces. Ideal traces are copies of PV's 1 to 5 and allow the user to save a trace for comparison on future traces.



Table 8-49 Capture Panel	
Field	Description
	<p>Click this icon and view the confirmation dialog box to copy the paired trace into the index.</p> <p>This is available on both the graph screen or the configuration screen.</p> 
Automatically update ideal traces	Enabling this option will automatically update/copy the paired trace to the that index.

Table 8-50 Options Panel	
Field	Description
Continuously Trace	Click the check box to have the trace automatically return to checking the trigger state and waiting to start again, once the trace has finished,
Save After Trace	Click the check box to automatically save the trace after it finishes.
Autosacle To Min/Max	After a trace is finished autosacle will automatically scale the PV's min and max values to fit the trace onto the graph.
Overwrite Oldest Trace (If save folder is full)	The trace folder is restricted in size. If the size limit is reached an error will be displayed when saving if we are not overwriting the oldest file. Requires that room is made in the user data trace folder or the oldest file should be overwritten.

Table 8-51 Process Variables Panel																	
Field	Description																
<table border="1"> <thead> <tr> <th>Enable</th> <th>Process Variable</th> <th>Scale Min</th> <th>Scale Max</th> <th>Minimum</th> <th>Maximum</th> <th>Unit</th> <th>Color</th> </tr> </thead> <tbody> <tr> <td><input checked="" type="checkbox"/></td> <td>Injection: Actual Position</td> <td>14.45</td> <td>82.89</td> <td>15.05</td> <td>75.35</td> <td>mm</td> <td>■</td> </tr> </tbody> </table>	Enable	Process Variable	Scale Min	Scale Max	Minimum	Maximum	Unit	Color	<input checked="" type="checkbox"/>	Injection: Actual Position	14.45	82.89	15.05	75.35	mm	■	<p>Settings of Process Variables</p> <p>Enable: Hide/Show trace on graph</p> <p>Process Variable: Name of the process variable (PV). Tap this field to open the PV selection dialog box.</p> <p>Scale Min: -1,000,000 to 1,000,000</p> <p>Scale Max: -1,000,000 to 1,000,000</p> <p>Minimum: Minimum value recorded during the trace</p> <p>Maximum: Maximum value recorded during the trace</p> <p>Unit: Associated units for the selected process variable</p> <p>Trace</p> <p>Color: Displays the trace color. Tap it to change the color.</p>
Enable	Process Variable	Scale Min	Scale Max	Minimum	Maximum	Unit	Color										
<input checked="" type="checkbox"/>	Injection: Actual Position	14.45	82.89	15.05	75.35	mm	■										

Table 8-52 Trigger Panel	
Field	Description
Mode	<p>Select the trigger mode to begin the trace.</p> <p>Values:</p> <p>Immediate - Trace begins as soon as the start/stop button is pressed</p> <p>Threshold - Trace begins as soon as the threshold conditions are met</p> <p>Cycle Start - Trace begins as soon as a new cycle is started</p> <p>Sequence - Trace starts based on the sequence step selected and the trigger set.</p>

8.15 Alarms

Tap the following buttons in the order shown to go to the Alarms screen.

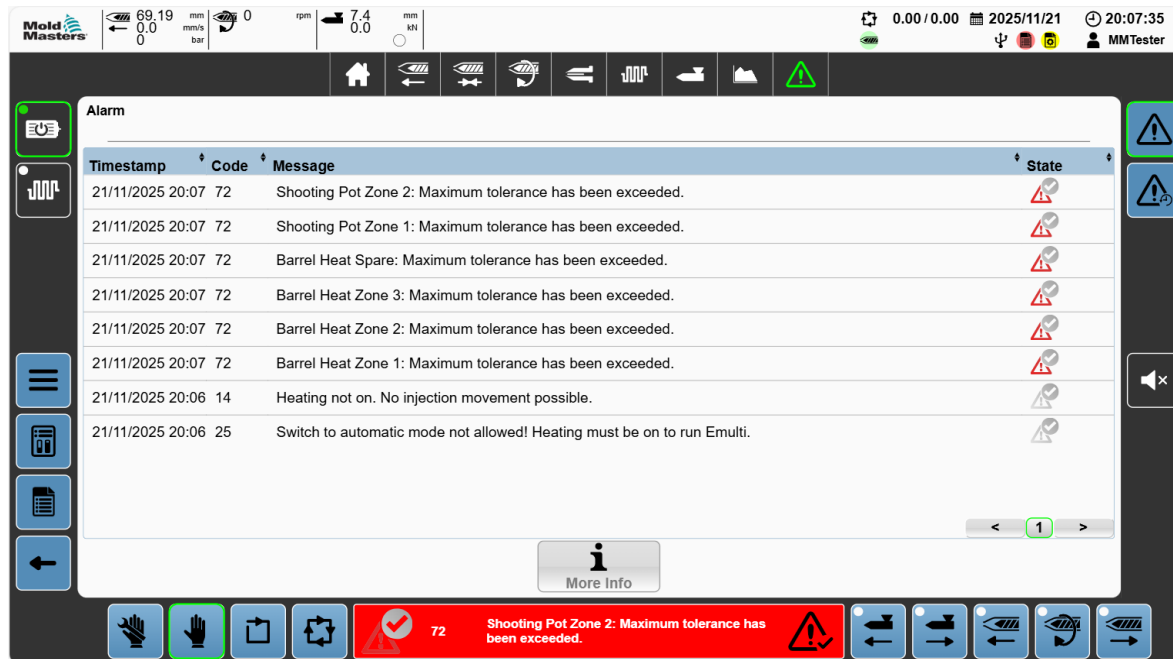
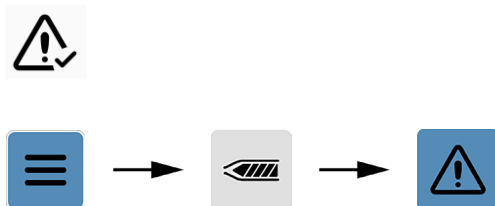

Figure 8-31 Alarms screen

Field/Button	Description
	<p>Displays all active alarms</p> <p>Tap a header to sort alarms by timestamp, code, message, or state.</p>
	<p>More Information Button</p> <p>Alarm messages preceded by an integer and followed by a colon have more detailed information available. To view this information, select an alarm and press this button to open the detailed alarm-dialog box.</p>

Table 8-53 Alarms Screen	
Field/Button	Description
	Alarm Paging Button If there are more alarms than the screen can display, use the previous, next, and screen index buttons to navigate the alarms.
	Tap this button to go to the Alarm screen.
	Tap this button to go to the Alarm History screen.
	Tap this button to switch off the buzzer (if installed separately).

8.15.1 Alarm History

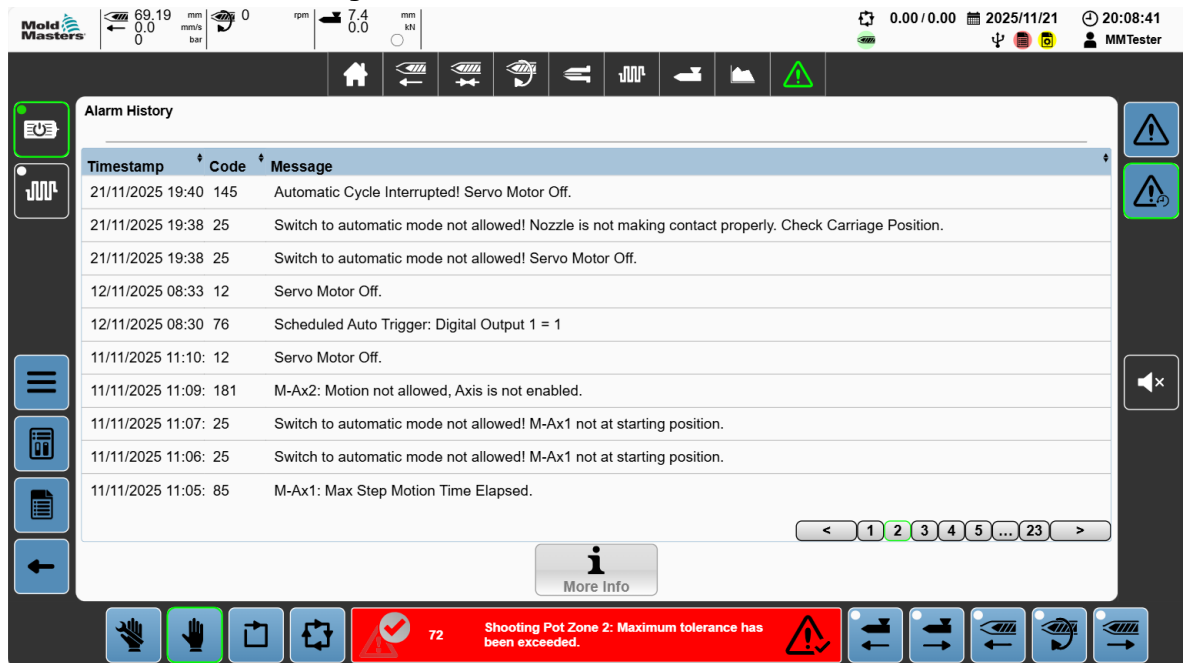

Figure 8-32 Alarm history screen

The Alarm history stores up to 1140 alarms which are retained until space needs to be made for more alarms.

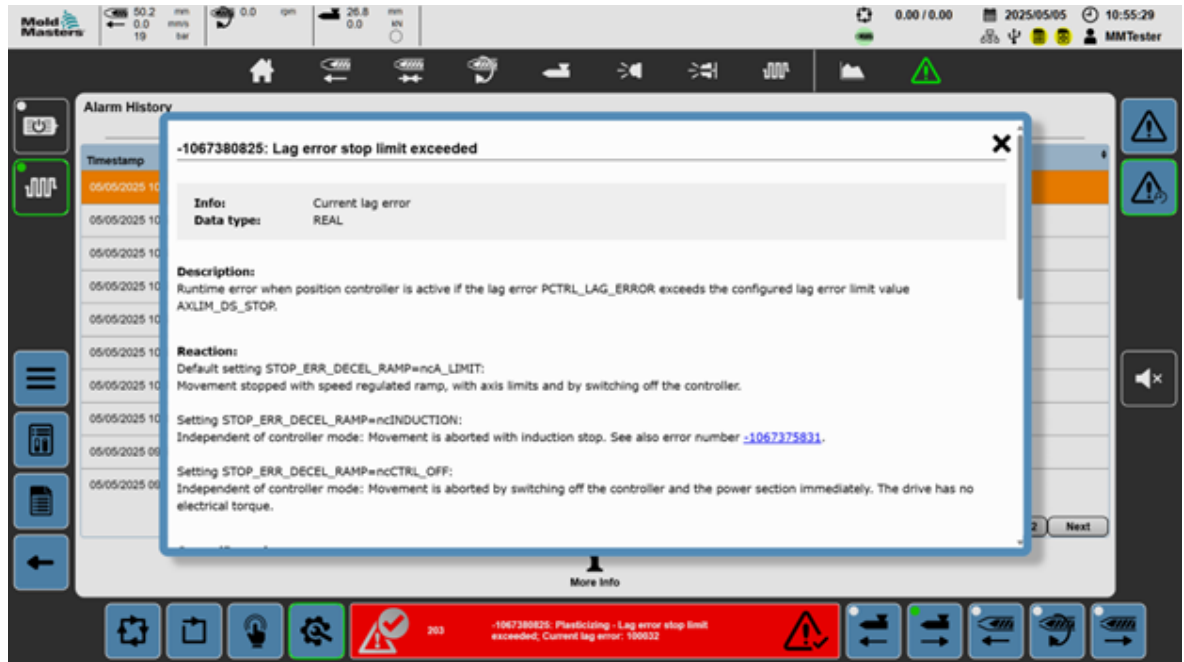

Figure 8-33 Detailed alarm box

The Detailed alarm box provides additional alarm information on internal errors.

8.16 Temperature

Tap the following buttons in the order shown to go to the Temperature screen.



8.16.1 Temperature Screen

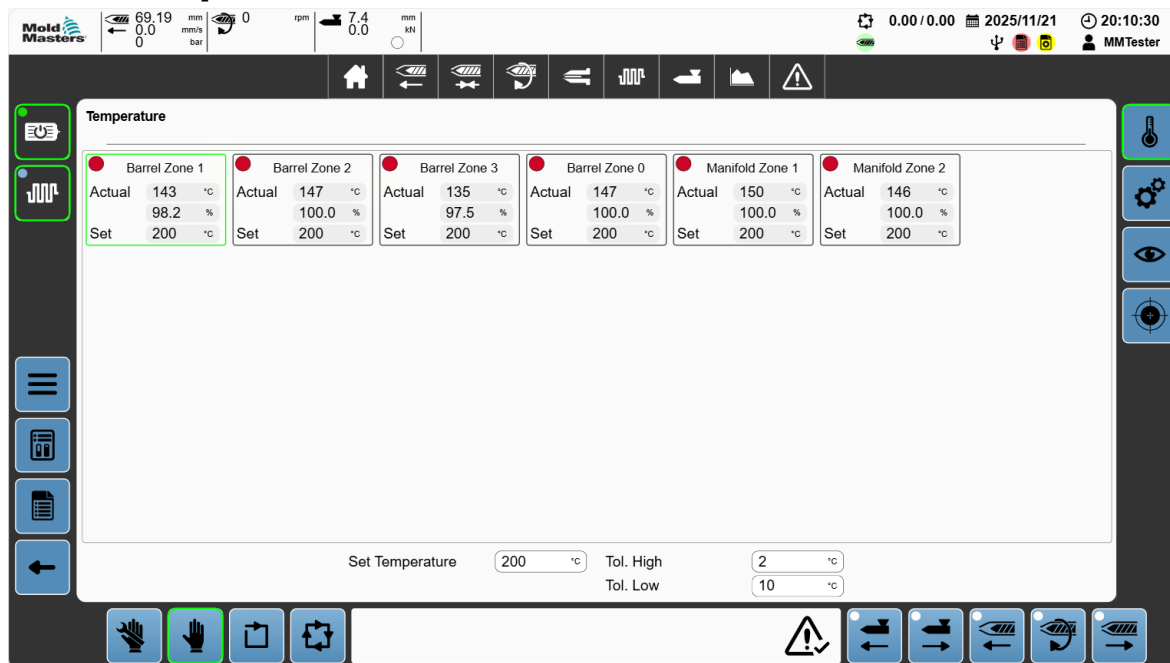

Figure 8-34 Temperature screen

Table 8-54 Temperature Screen	
Field	Description
	Displays the critical values for a heating zone
	LED: Heating-output active state. Name of the heating zone
	Actual Actual temperature of the zone
	Output active percentage for the zone-pulse-width modulation controller
	Set Set temperature for the zone
	Set Temperature Temperature set point for the selected zone Values: Any positive value in °C

Table 8-54 Temperature Screen	
Field	Description
Tol. High <input type="text" value="10.0"/> °C	Tol. (Tolerance) High Tap this field to set the high tolerance of the set temperature for selected zone. Values: Any positive value in °C
Tol. Low <input type="text" value="10.0"/> °C	Tol. Low Values: Any positive value in °C Tap this field to set the low tolerance of the set temperature for the selected zone

8.16.2 Temperature Monitoring

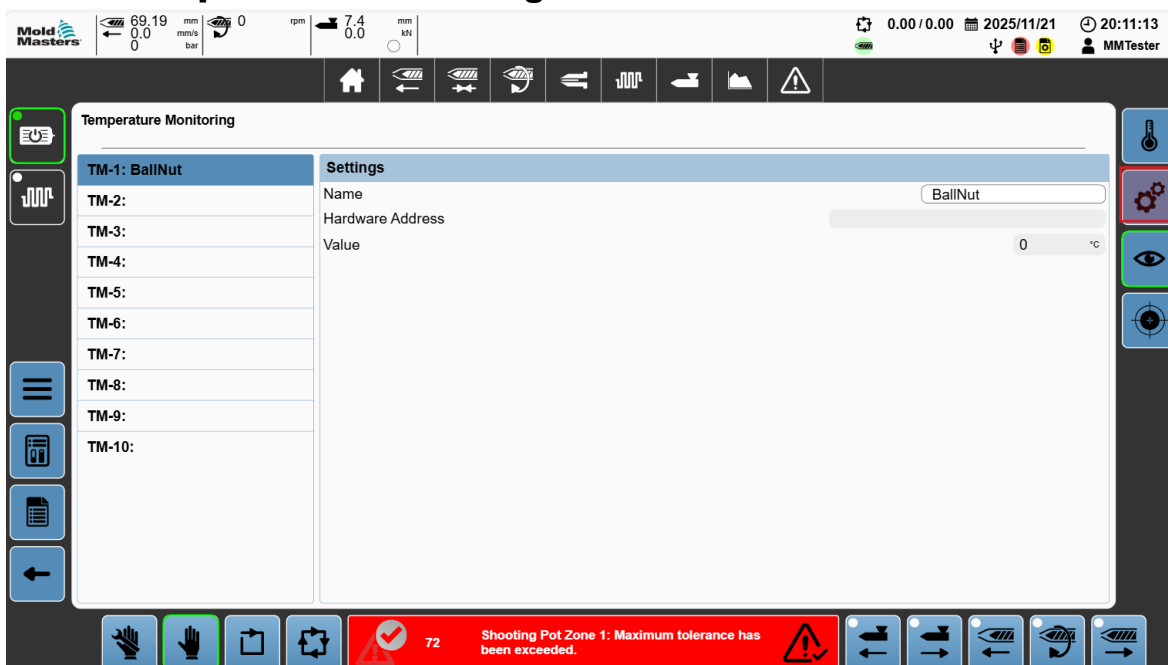

Figure 8-35 Temperature monitoring screen

Tap a temperature monitoring zone in the left panel to view the settings of the zone.

Table 8-55 Settings Panel	
Field	Description
Name	User defined name for the monitoring zone Values: Any text string, 27 characters displayed Tap this field to enter a name for the zone.
Hardware Address	Text string indicating the hardware module and location for the temperature monitoring input
Value	Current temperature of the zone

8.17 I/O

Tap the following buttons in the order shown to go to the Digital Inputs screen.



8.17.1 Digital Inputs

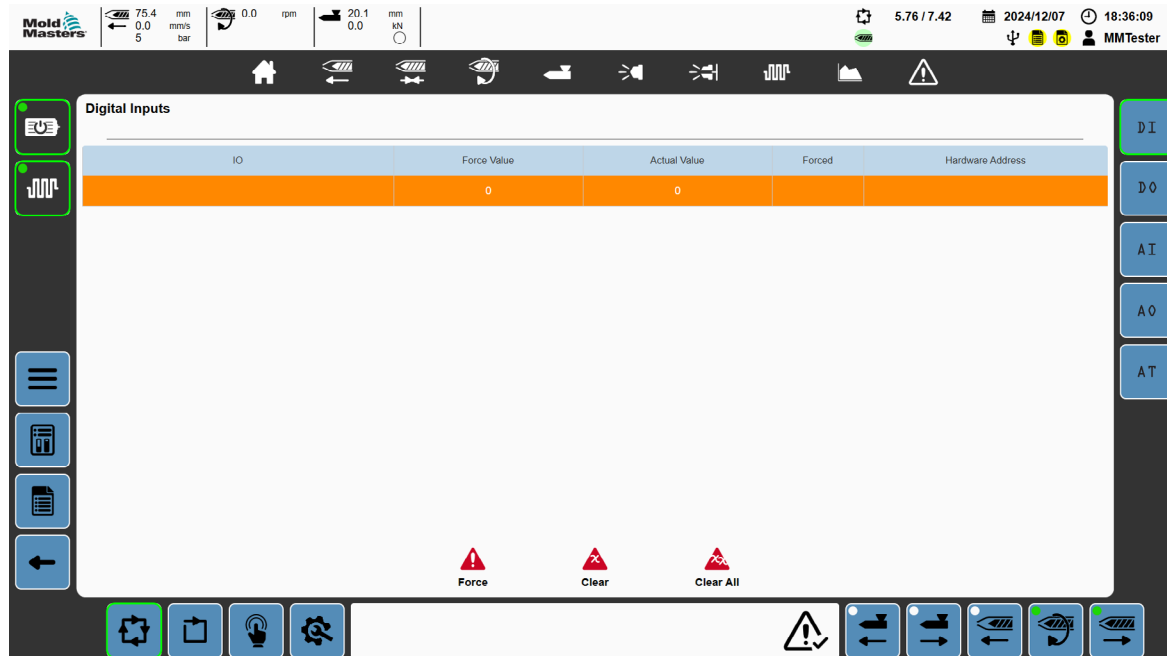
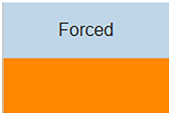
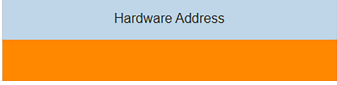





Figure 8-36 Digital inputs screen

Table 8-56 Digital Inputs Screen	
Field/ Buttons	Description
	<p>I/O</p> <p>List of all available inputs</p> <p>Displays the internal software name for the input</p>
	<p>Force Value</p> <p>Requested value the input is to be forced to</p> <p>Values: 0 to 1</p> <p>When an input is forced, the internal software reads the force value for the input and not the actual value.</p>
	<p>Actual Value</p> <p>Actual value for the input read at the hardware</p> <p>When an input is forced, the internal software reads the force value for the input and not the actual value.</p>

Table 8-56 Digital Inputs Screen	
Field/ Buttons	Description
	<p>Forced</p> <p>Displays the Forced icon (red triangle containing white exclamation mark) for any input that is being forced</p>
	<p>Hardware Address</p> <p>Text string indicating the hardware module and location for the digital input</p>
	<p>Force</p> <p>Tap this button to force the selected input to take the value set in the Force Value field.</p>
	<p>Clear</p> <p>Internal software value for the input returns to the actual value</p> <p>Tap this button to clear the force from the selected input.</p>
	<p>Clear All</p> <p>Clears forcing from all digital and analog signals Tap this button to clear the force from all I/O.</p>

8.17.2 Digital Outputs

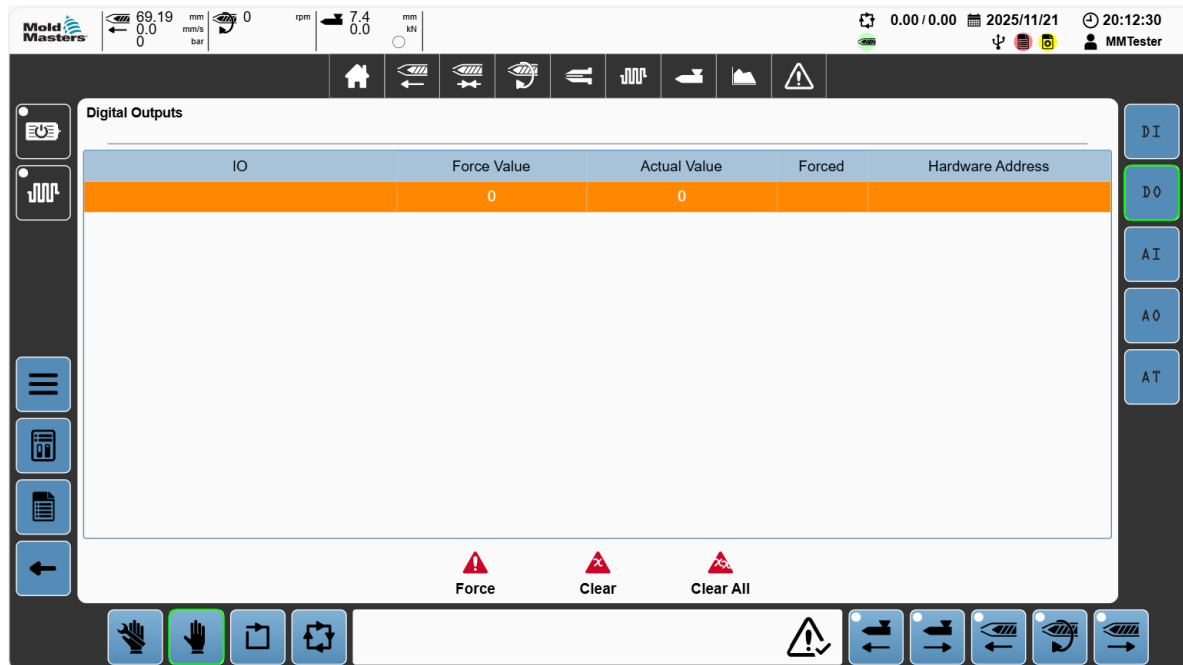

Figure 8-37 Digital outputs screen

Table 8-57 Digital Outputs Screen	
Field/ Buttons	Description
	<p>I/O</p> <p>List of all available inputs</p> <p>Displays the internal software name for the input</p>
	<p>Force Value</p> <p>Requested value the output is to be forced to</p> <p>Values:</p> <ul style="list-style-type: none"> -32767 represents the maximum negative signal for the analog input +32767 represents the maximum positive signal for the analog input <p>When an input is forced, the internal software reads the force value for the input and not the actual value</p>
	<p>Actual Value</p> <p>Actual value for the output read at the hardware</p> <p>When an output is forced, the actual value is set to the force value</p>
	<p>Forced</p> <p>Displays the Forced icon (red triangle containing white exclamation mark) for any output that is being forced</p>

Table 8-57 Digital Outputs Screen	
Field/ Buttons	Description
	<p>Hardware Address</p> <p>Text string indicating the hardware module and location for the digital output</p>
	<p>Force</p> <p>Tap this button to force the selected output to take the value set in the Force Value field.</p>
	<p>Clear</p> <p>Internal software value for the output returns to the actual value Tap this button to clear the force from the selected output.</p>
	<p>Clear All</p> <p>Clears forcing from all digital and analog signals Tap this button to clear the force from all I/O.</p>

8.17.3 Analog Inputs

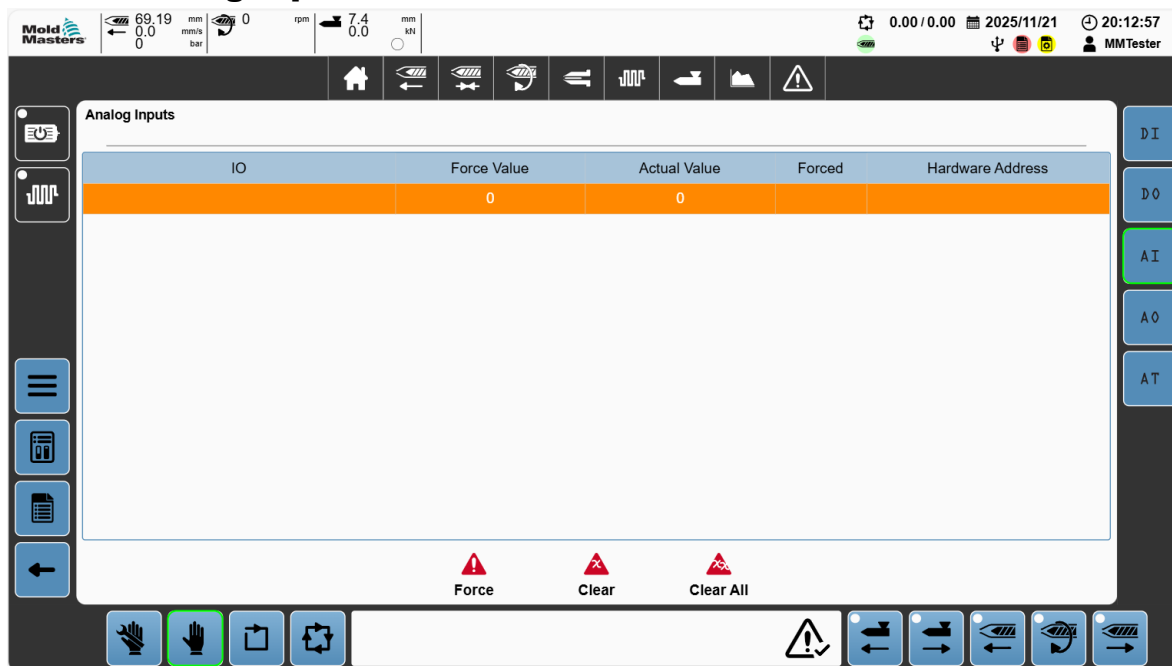
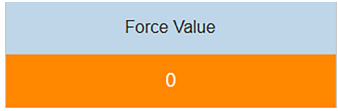
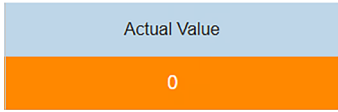
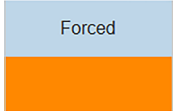
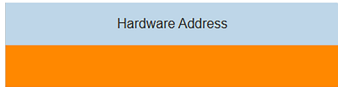





Figure 8-38 Analog inputs screen

Table 8-58 Analog Inputs Screen	
Field/ Buttons	Description
	<p>I/O</p> <p>List of all available inputs</p> <p>Displays the internal software name for the input</p>

Table 8-58 Analog Inputs Screen	
Field/ Buttons	Description
	<p>Force Value</p> <p>Requested value the input is to be forced to</p> <p>Values:</p> <p>-32767 represents the maximum negative signal for the analog input</p> <p>+32767 represents the maximum positive signal for the analog input</p> <p>When an input is forced, the internal software reads the force value for the input and not the actual value.</p>
	<p>Actual Value</p> <p>Actual value for the input read at the hardware</p> <p>When an input is forced, the internal software reads the force value for the input and not the actual value.</p>
	<p>Forced</p> <p>Displays the Forced icon (red triangle containing white exclamation mark) for any input that is being forced</p>
	<p>Hardware Address</p> <p>Text string indicating the hardware module and location for the analog input</p>
	<p>Force</p> <p>Tap this button to force the selected input to take the value set in the Force Value field.</p>
	<p>Clear</p> <p>Internal software value for the input returns to the actual value</p> <p>Tap this button to clear the force from the selected input.</p>
	<p>Clear All</p> <p>Clears forcing from all digital and analog signals Tap this button to clear the force from all I/O.</p>

8.17.4 Analog Outputs

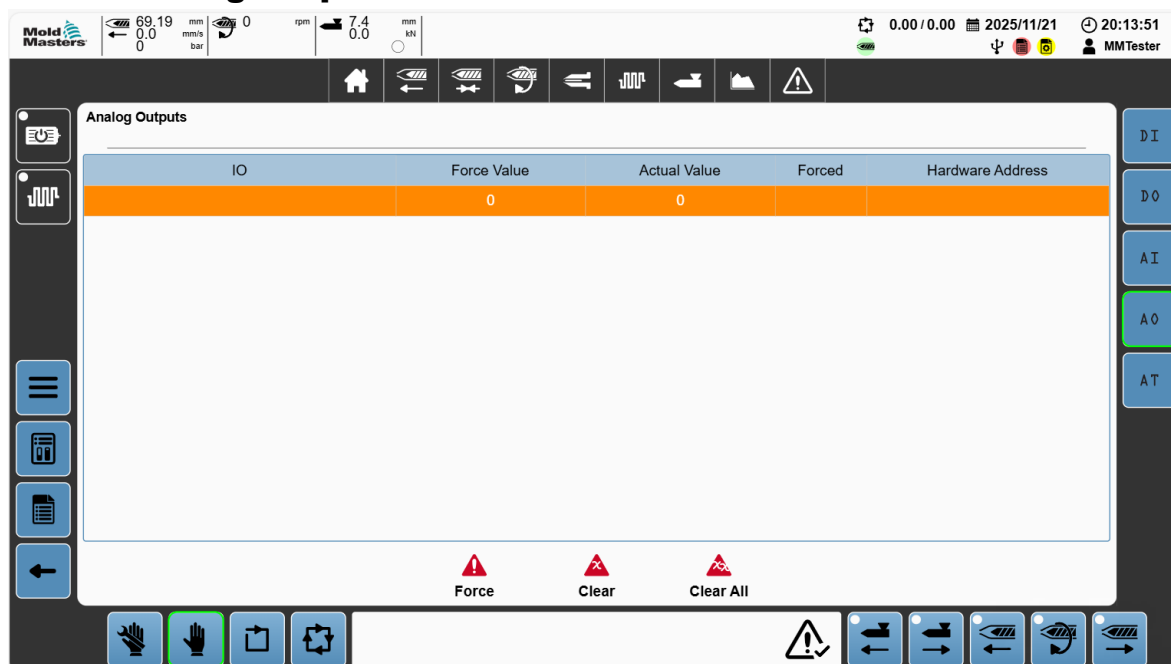

Figure 8-39 Analog outputs screen

Table 8-59 Analog Outputs Screen	
Field/ Buttons	Description
	<p>I/O</p> <p>List of all available outputs</p> <p>Displays the internal software name for the output</p>
	<p>Force Value</p> <p>Requested value the output is to be forced to</p> <p>Values:</p> <p>-32767 represents the maximum negative signal for the analog output</p> <p>+32767 represents the maximum positive signal for the analog output</p>
	<p>Actual Value</p> <p>Actual value for the output read at the hardware</p> <p>When an output is forced, the actual value is set to the force value.</p>
	<p>Forced</p> <p>Displays the Forced icon (red triangle containing white exclamation mark) for any output that is being forced</p>
	<p>Hardware Address</p> <p>Text string indicating the hardware module and location for the analog output</p>

Table 8-59 Analog Outputs Screen	
Field/ Buttons	Description
 Force	Force Tap this button to force the selected output to take the value set in the Force Value field.
 Clear	Clear Internal software value for the output returns to the actual value Tap this button to clear the force from the selected output.
 Clear All	Clear All Clears forcing from all digital and analog signals Tap this button to clear the force from all I/O.

8.17.5 Analog Temperature

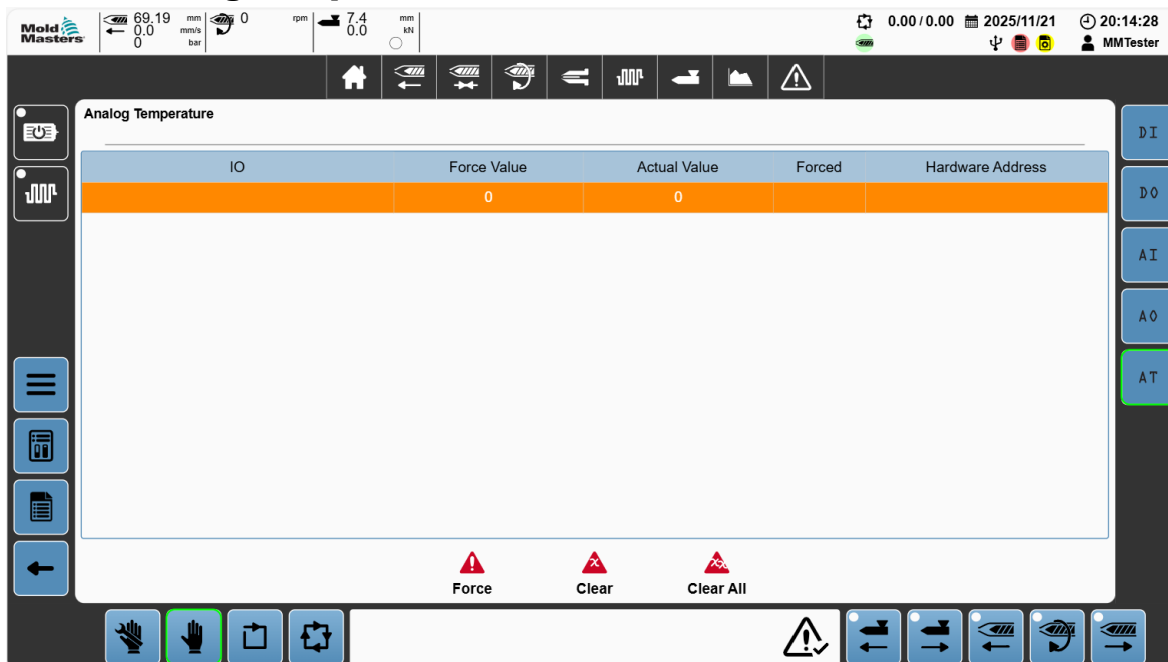
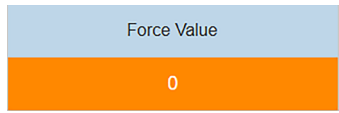
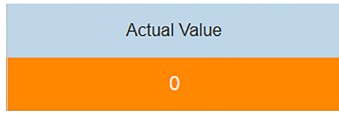
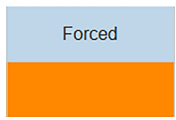





Figure 8-40 Analog temperature screen

Table 8-60 Analog Temperature Screen	
Field/ Buttons	Description
 IO	List of all available temperature inputs Displays the internal software name for the input

Table 8-60 Analog Temperature Screen	
Field/ Buttons	Description
	<p>Force Value</p> <p>Requested value the temperature input is to be forced to</p> <p>Values:</p> <p>-32767 represents the maximum negative signal for the temperature input</p> <p>+32767 represents the maximum positive signal for the temperature input</p> <p>When an input is forced, the internal software reads the force value for the input and not the actual value.</p>
	<p>Actual Value</p> <p>Actual value for the temperature input read at the hardware</p> <p>When an input is forced, the internal software reads the force value for the input and not the actual value</p>
	<p>Forced</p> <p>Displays the Forced icon (red triangle containing white exclamation mark) for any temperature input that is being forced</p>
	<p>Hardware Address</p> <p>Text string indicating the hardware module and location for the temperature analog input</p>
	<p>Force</p> <p>Tap this button to force the selected input to take the value set in the Force Value field.</p>
	<p>Clear</p> <p>Internal software value for the input returns to the actual value</p> <p>Tap this button to clear the force from the selected temperature input.</p>
	<p>Clear All</p> <p>Clears the force from all digital and analog signals Tap this button to clear the force from all I/O.</p>

8.18 Custom I/O

Tap the Directory screen button to access the Custom I/O screen.



8.18.1 Custom Digital Inputs

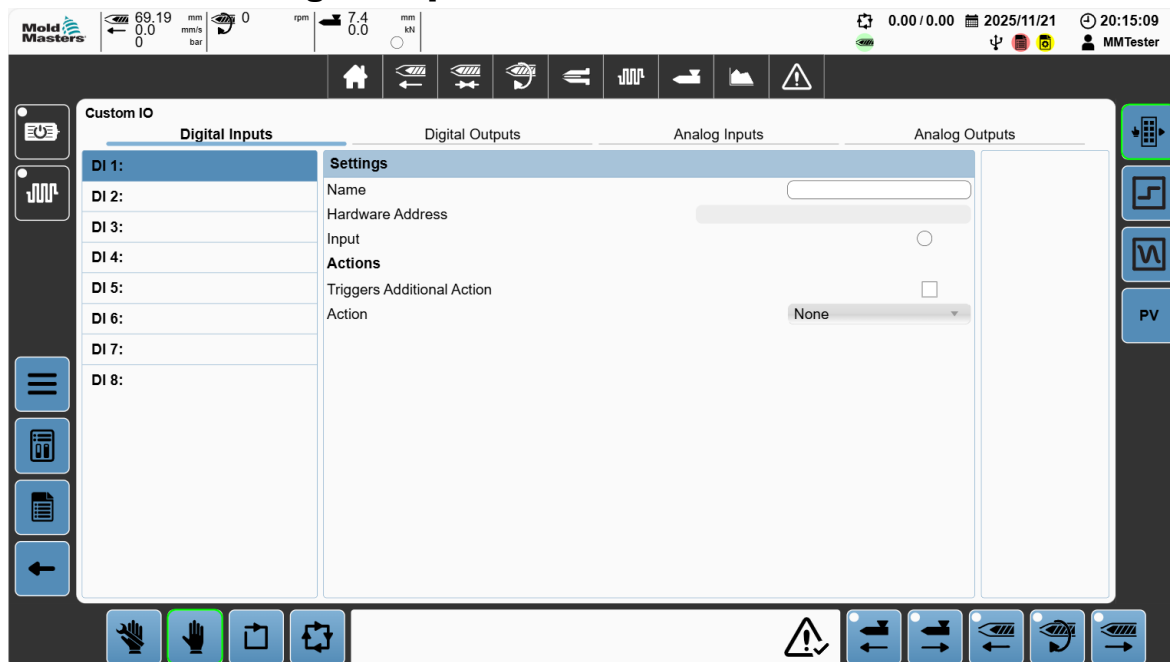

Figure 8-41 Custom digital inputs panel

Table 8-61 Digital Inputs Panel	
Field	Description
Name	Custom name Values: Any string
Hardware Address	Address of the hardware location for the selected I/O
Input	Red - Shows the current status of the input when the LED is red Off - Does not show the current status of the input when LED is off
Actions	
Triggers Additional Action	If this checkbox is checked, a rising edge of the I/O can trigger additional actions. Values: Checked or unchecked
Action	Selected additional action will be triggered on rising edge of the digital input Values: <ul style="list-style-type: none"> • None • Heats On (E-Multi only) • HRC On

8.18.2 Custom Digital Outputs

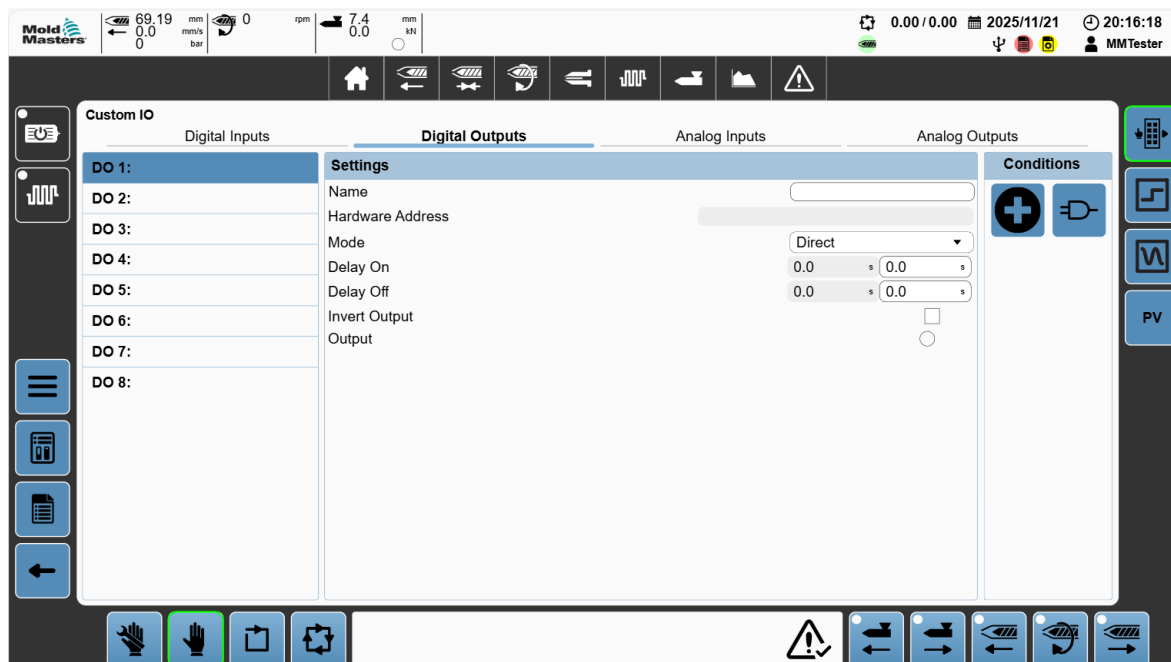



Figure 8-42 Custom digital outputs panel

Table 8-62 Digital Outputs Panel	
Field	Description
Name	Custom name Values: Any string
Hardware Address	Address of the hardware location for the selected I/O
Mode	Digital output mode Values: Direct - Controlled directly from the conditions evaluation. If the evaluation is true, the output is on; if it is false, the output is off. Timed - On a rising edge of the condition evaluation, the output is turned on for the set amount of time. If the conditions evaluation is false before the time has elapsed or once the timer has elapsed, then the output is turned off. Pulsed - While the condition evaluation is true, the output is pulsed for the set pulse time. Switched - Switched Mode allows the operator to set an On Trigger and an Off Trigger. When the On Trigger conditions are met the output is turned on. The output stays in the on state until the Off Trigger conditions are met.

Table 8-62 Digital Outputs Panel	
Field	Description
Delay On	<p>Delay On</p> <p>Values: Any positive value</p> <p>When the condition evaluation is true, there is a delay of this amount of time before controlling the output based on the mode.</p>
Delay Off	<p>Delay Off</p> <p>Value: Any positive value</p> <p>When the condition evaluation is false. there is a delay of this amount of time before controlling the output based on the mode.</p>
Invert Output	<p>Click the check box to invert the output after all the evaluations</p> <p>Values: Checked or Unchecked</p>
Output	<p>Displays the output state</p> <p>Values: Red or off</p>

Table 8-63 Conditions Panel	
Field	Description
	<p>New conditions button</p> <p>Add new conditions</p> <p>Tap the new condition button to open a new detailed-condition dialog box for the selected motion step.</p>
	<p>Edit condition logic</p> <p>Tap the edit logic button to set up the conditions AND/OR evaluation. By default all conditions are ANDed together.</p>

8.18.3 Analog Inputs

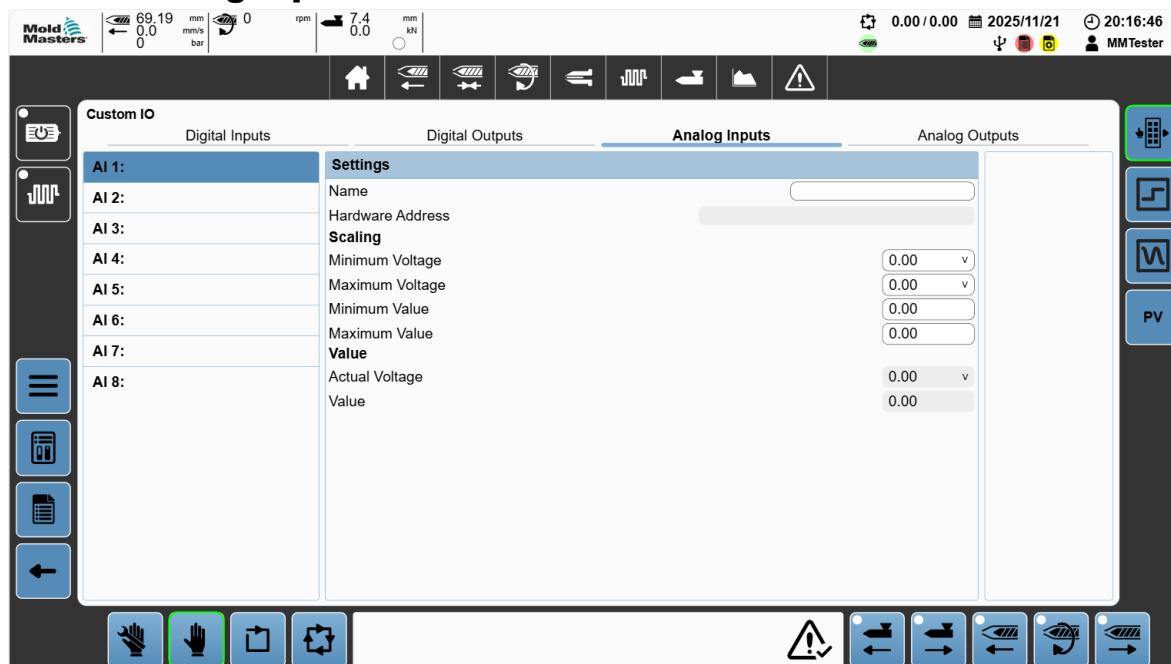

Figure 8-43 Custom I/O screen with the Analog Inputs tab selected

Table 8-64 Analog Inputs Tab	
Field	Description
Name	Custom name Values: Any string
Hardware Address	Address of the hardware location for the selected I/O Values: Hardware location
Minimum Voltage	Minimum input voltage for scaling the input Values: -10 V to 10 V
Maximum Voltage	Maximum input voltage for scaling the input Values: -10 V to 10 V
Minimum Value	Minimum value for scaling the input Values: Any negative value up to maximum positive value
Maximum Value	Maximum value for scaling the input Values: Any negative value up to maximum positive value
Actual Voltage	Actual voltage at the card Values: -10 V to +10 V
Value	Scaled value Values: Any value

8.18.4 Analog Outputs

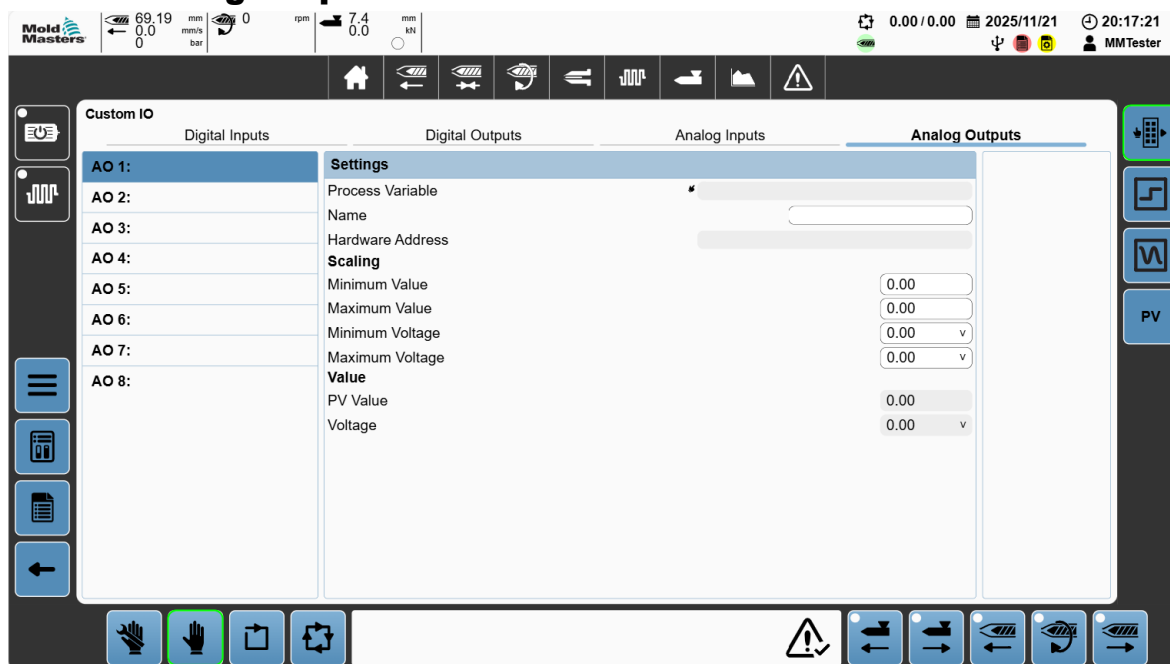

Figure 8-44 Custom I/O screen with the Analog Outputs tab selected

Table 8-65 Analog Outputs Tab

Field	Description
Process Variable	Tap anywhere in this field to select a process variable (PV). Values: Process variable The process variable value will be scaled and output on the customized analog output channel.
Name	Custom name. Values: Any string
Hardware Address	Address of the hardware location for the selected I/O
Minimum Value	Minimum value for scaling the input. Values: Any negative value up to maximum positive value
Maximum Value	Maximum value for scaling the input. Values: Any negative value up to maximum positive value
Minimum Voltage	Minimum input voltage for scaling the input. Values: -10 V to 10 V
Maximum Voltage	Maximum input voltage for scaling the input. Values: -10 V to 10 V
PV Value	Current value of the selected process variable
Voltage	Scaled voltage output of the selected process variable

8.18.5 Custom Digital I/O

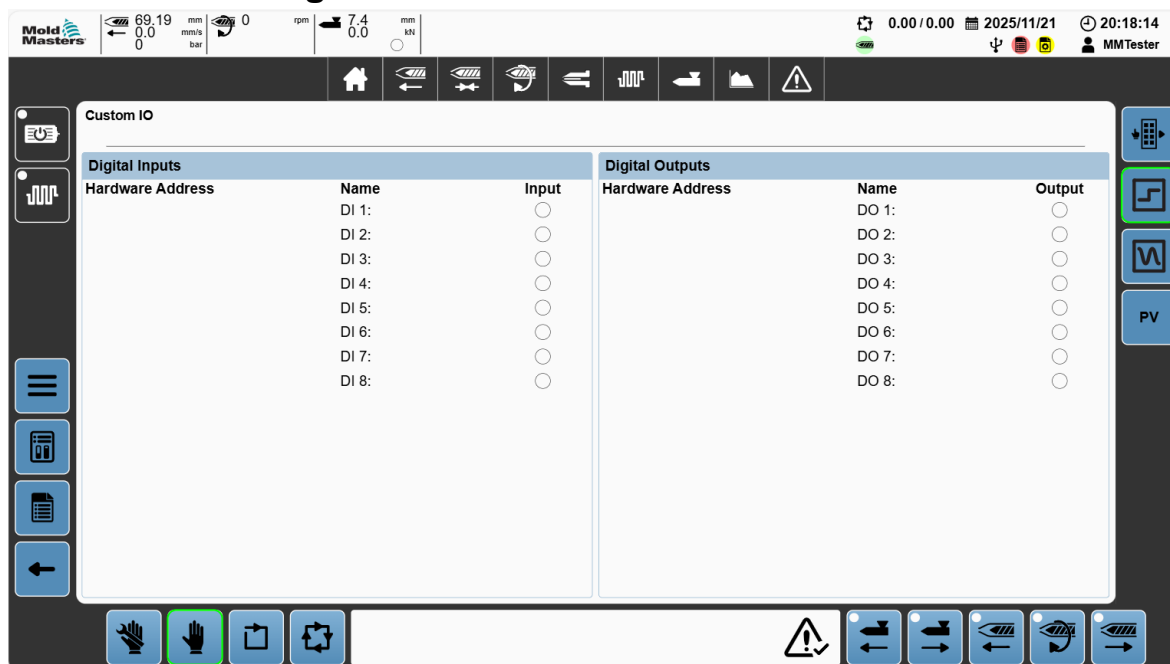

Figure 8-45 Custom digital I/O screen

Table 8-66 Digital Inputs Panel	
Field	Description
Hardware Address	Address of the hardware location for the selected I/O
Name	Custom name Values: Any string
Input	Red - Shows the current status of the input when the LED is red Off - Does not show the current status of the input when LED is off

Table 8-67 Digital Outputs Panel	
Field	Description
Hardware Address	Address of the hardware location for the selected I/O
Name	Custom name Values: Any string
Output	Red - Shows the current status of the input when the LED is red Off - Does not show the current status of the input when LED is off

8.18.6 Custom Analog I/O

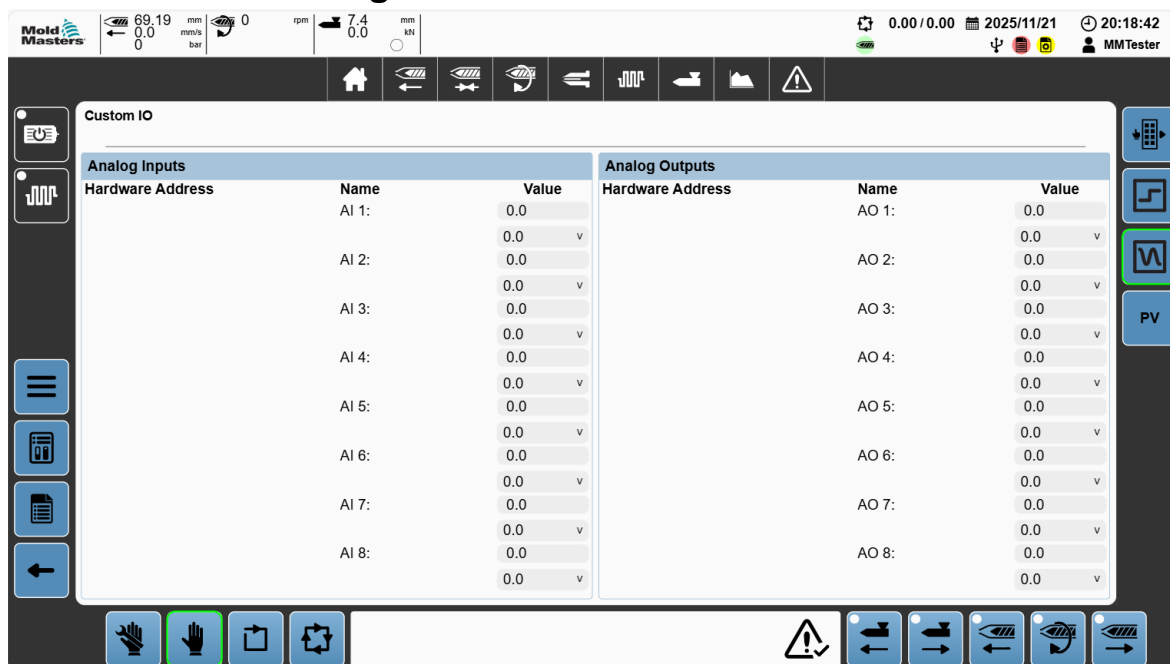

Figure 8-46 Custom I/O screen with the Custom Process Variables screen

Table 8-68 Analog Inputs Panel	
Field	Description
Hardware Address	Address of the hardware location for the selected I/O
Name	Custom name Values: Any string
Value	Displays the scaled value Value: Any value Displays the actual voltage readback Value: -10 to +10 V

Table 8-69 Analog Outputs Panel	
Field	Description
Hardware Address	Address of the hardware location for the selected I/O
Name	Custom name Values: Any string
Value	Displays the current process variable value Value: Any value Displays the scaled voltage value to be set Value: -10 to +10 V

8.18.7 Custom Process Variables

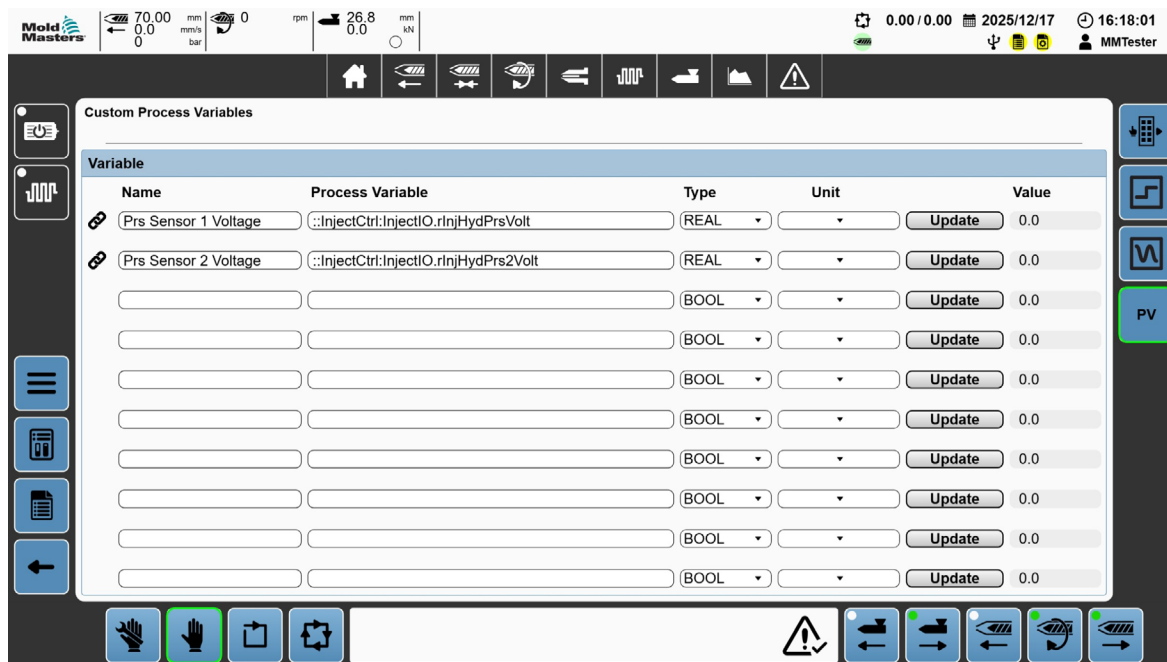

Figure 8-47 Custom process variables screen

Table 8-70 Variable Panel	
Field	Description
Name	Name to be displayed for custom process variable in the Conditions and Process Variable Selection lookup tables
Process Variable	Internal PLC name of the process variable to use. This value is supplied by Mold Masters.
Type	The variable type of the selected process variable; supplied by Mold-Masters.
Unit	The unit of measure for the process variable, if applicable.
Update	Press the Update button after defining the process variable, type, and unit to connect the custom process variable to the internal variable.
Value	The current value of the connected internal process variable

8.19 Axis Information

Tap the following buttons in the order shown to go to the Axis screen.



8.19.1 Temperature Tab

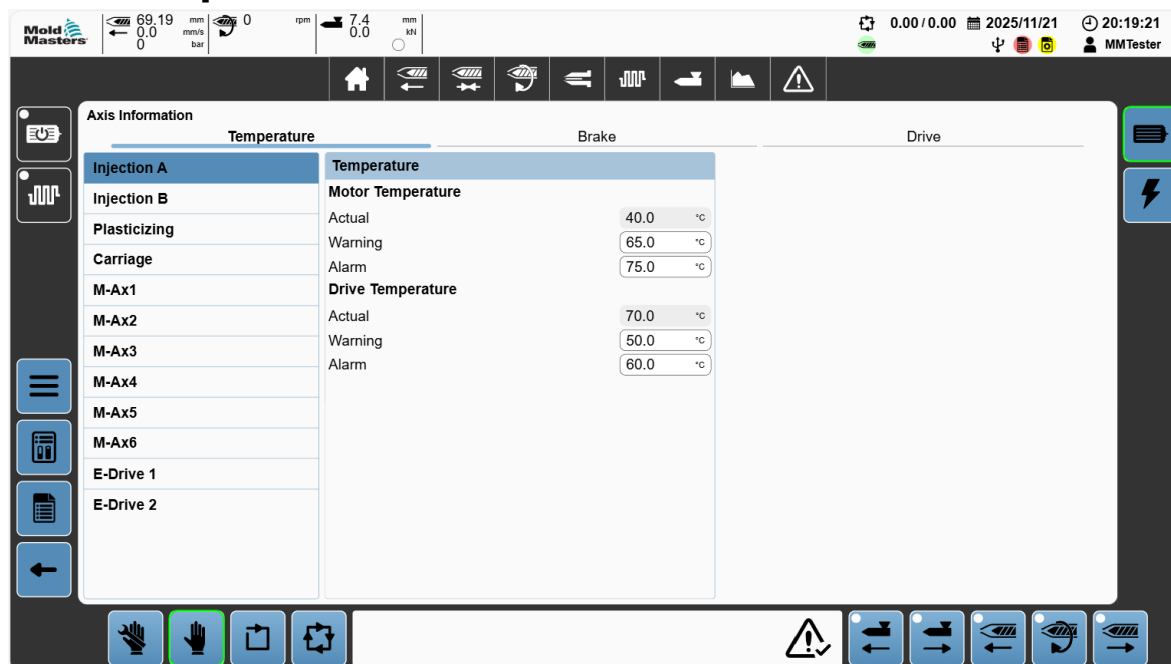

Figure 8-48 Axis information screen with the Temperature tab selected

Tap an axis in the left column to view its sensor parameters:

Table 8-71 Temperature Tab	
Field	Description
Motor Temperature	
Actual	Actual temperature of the servo motor
Warning	Maximum temperature of the servo motor that will generate a warning message Values: Any positive number °C
Alarm	Maximum temperature of the servo motor that will trigger an alarm. Values: Any positive number °C
Drive Temperature	
Actual	Actual temperature of the servo drive
Warning	Maximum temperature of the servo drive that will generate a warning message Values: Any positive number °C
Alarm	Maximum temperature of the servo drive that will trigger an alarm Values: Any positive number °C

8.19.2 Brake Tab

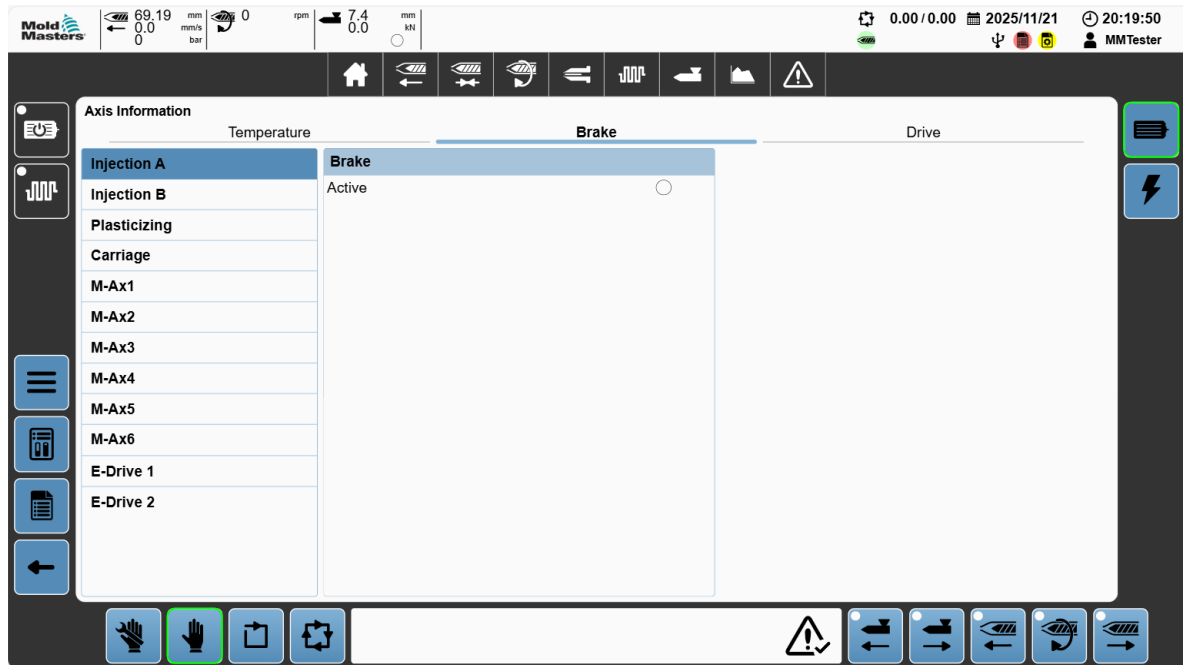

Figure 8-49 Axis information screen with the Brake tab selected

Tap an axis in the left column to view its sensor parameters.

Table 8-72 Brake Tab	
Field	Description
Active	Red - If LED is red, status of servo motor brake is shown Off - If LED is off, status of servo motor brake is not shown

8.19.3 Drive Tab

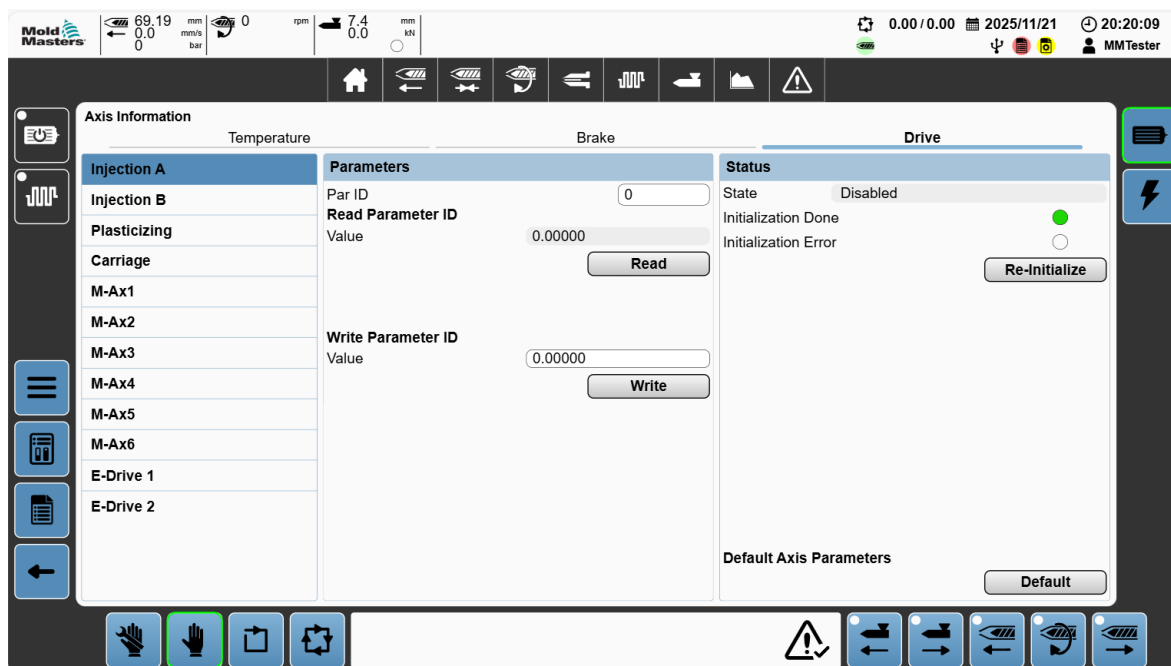



Figure 8-51 Axis information screen with the Drive tab selected

Tap an axis in the left column to view its sensor parameters.

Table 8-73 Drive Tab	
Field	Description
Par ID	B&R servo-drive parameter-identity number to access Values: Any positive integer up to 65,535
Read Parameter	
Value	Current value of the selected drive parameter
	Read button Tap this button to read the current value of the entered Par ID
Write Parameter ID	
Value	Tap this field to enter a value for the selected drive parameter.
	Write button Tap this button to write the entered value to the entered Par ID.

8.19.4 Power Supply

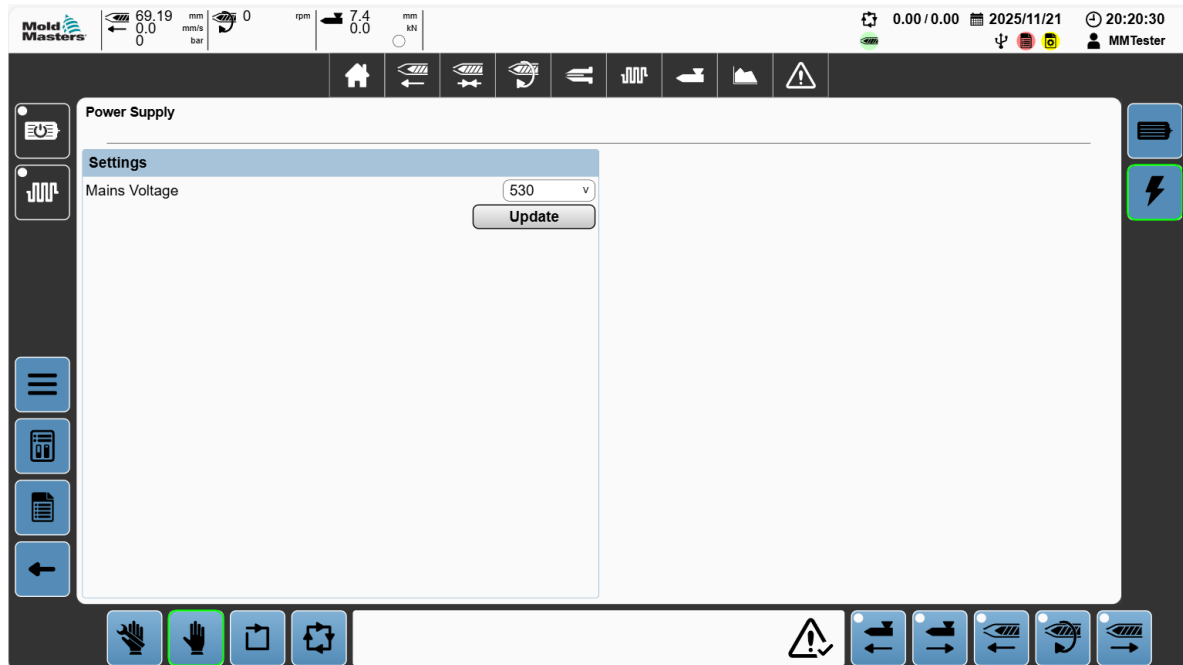



Figure 8-52 Power supply screen

Table 8-74 Settings Panel	
Field/ Buttons	Description
Mains Voltage	Incoming mains voltage Values: 0 V to 65,535 V
	Update power supply button Tap this button to update the power supply with the set mains voltage

8.20 HMI Configuration

Tap the following buttons in the order shown to go to the HMI Configuration screen.

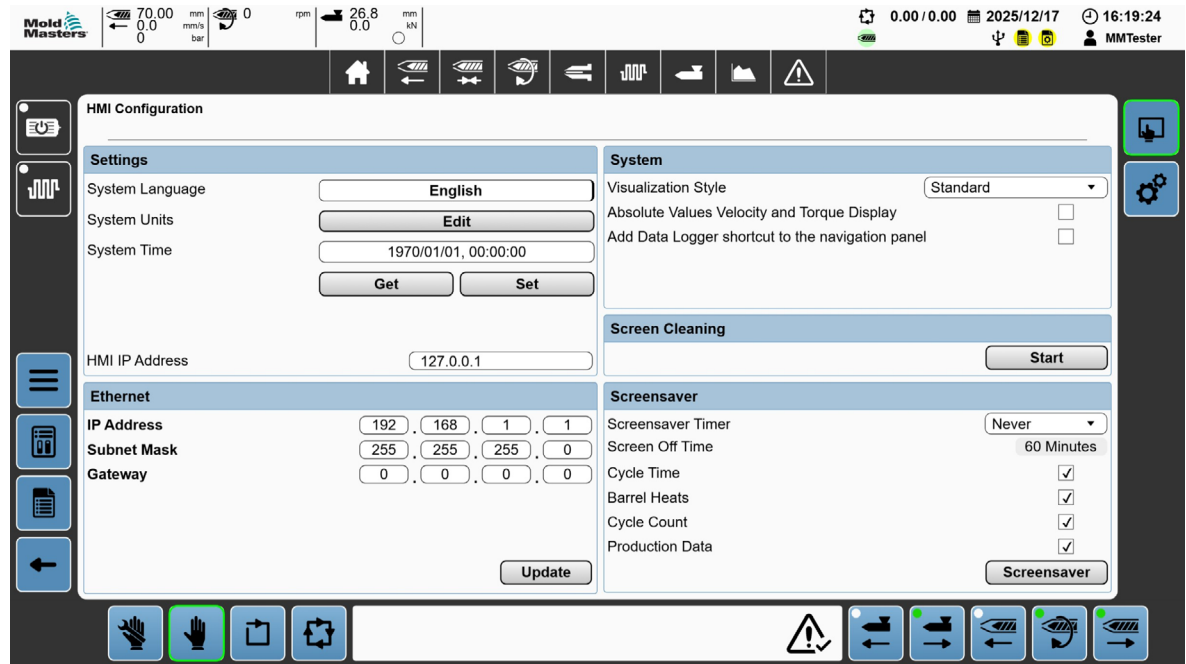

Figure 8-53 HMI configuration screen

Table 8-75 Settings Panel	
Field/ Buttons	Description
System Language <input type="text" value="English"/>	System Language Tap this field to select the system language
System Units <input type="text" value="Metric"/>	System Units Tap this field to select the system units.

Table 8-75 Settings Panel	
Field/ Buttons	Description
	<p>System Time</p> <p>Tap the Get button to update the date and time selector with the current date and time. Tap the Set button to update the system date time with the date and time selector value.</p> <p>Tap the date and time field to change the date and time value manually.</p> 
HMI IP Address	IP address of the touchscreen

Table 8-76 Ethernet Panel	
Field	Description
	<p>Ethernet</p> <p>IP Address</p> <p>Subnet Mask</p> <p>Tap the update button to change the system's Ethernet parameters.</p>

Table 8-77 System Panel	
Field	Description
Visualization Style	<p>Standard – Standard color theme</p> <p>Dark Mode – Dark mode color theme</p> <p>Standard Small – Standard color theme with small font</p> <p>Dark Small – Dark mode color theme with small font</p>
Absolute Values Velocity and Torque Display	<p>If checked, the velocity and torque displays will be the absolute values</p> <p>If unchecked, the velocity and torque will be positive or negative depending on the direction of motion</p>

Table 8-77 System Panel	
Field	Description
Add Data Logger shortcut to the navigation panel	If checked, the data logger shortcut will be added to the navigation panel

Table 8-78 Screen Cleaning	
Field	Description
	Disables the touchscreen input for 30 seconds to allow for cleaning of the screen

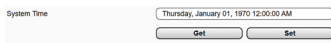
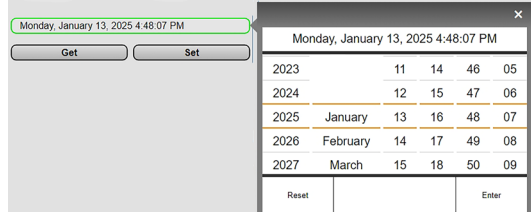
Table 8-79 Screensaver Panel	
Field	Description
Screensaver Timer	Tap this selector to change the screensaver timer. After the selected amount of time without any activity, the HMI will display the screensaver.
Screen Off Time	After 60 minutes of no activity, the backlight on the HMI will turn off. Any activity will wake up the HMI.
Cycle Time	Tap this check box to have the current and previous cycle times included on the screensaver screen.
Barrel Heats	Tap this check box to have the current barrel-heat temperatures and duty cycle times included on the screensaver screen.
Cycle Count	Tap this check box to have the current machine cycle count included on the screensaver screen.
Production Data	Tap this check box to have the current and target count of produced parts included on the screensaver screen.
	Screensaver button Tap this button to go to the Screensaver.

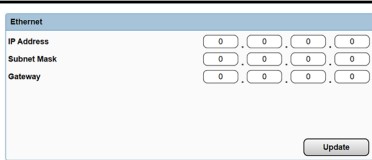
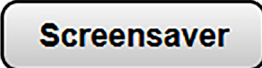
8.21 Euromap 67 (E67)

Tap the following buttons in the order shown to go to the Euromap 67 screen.

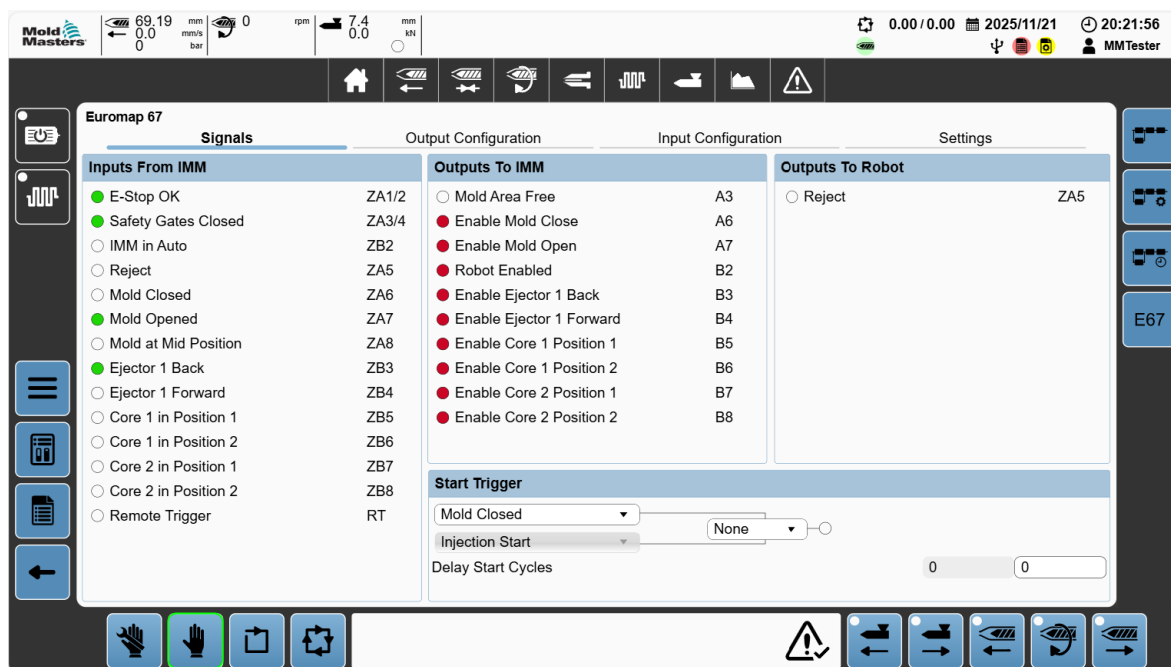
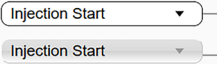



Figure 8-54 E67 screen with the Signals tab selected

Table 8-80 Signals Tab	
Field	Description
Inputs from IMM	A summary of digital input signals from the IMM through the Euromap 67 interface Values: Green or off
Outputs to IMM	A summary of digital output signals to the IMM through the Euromap 67 interface Values: Red or off
Outputs to Robot	A summary of signals passed to the robot (In the case that the E67 interface is daisy-chained to another device.)

Table 8-81 Start Trigger Panel	
Field/Button	Description
	<p>E-Multi auto cycle start triggers has the following dropdown options:</p> <ul style="list-style-type: none"> • Injection Start • Mold Closed • Ejector 1 Back • Ejector 1 Forward • Core 1 In Position 1 • Core 2 In Position 2 • IMM Screw Position • Remote Trigger • No Trigger <p>Two triggers are available, but the second trigger is optional.</p> <p>The E-Multi Mini injection sequence starts when the start condition changes from false to true.</p>
	<p>Logic selection for the injection start triggers</p> <p>AND - Both the start trigger conditions must be satisfied to start injection.</p> <p>OR - Injection starts when either of the start trigger conditions are satisfied.</p> <p>None - When the first start trigger condition is used (second condition cannot be set).</p>
	<p>Delay Start Cycles</p> <p>Actual delayed cycle count is shown in the grayed-out field.</p> <p>Delays the start of the first cycle of the E-Multi Mini until the start trigger is observed the number of times set here.</p> <p>Values: 0 and 255</p>

8.21.1 E67 Output Configuration Tab

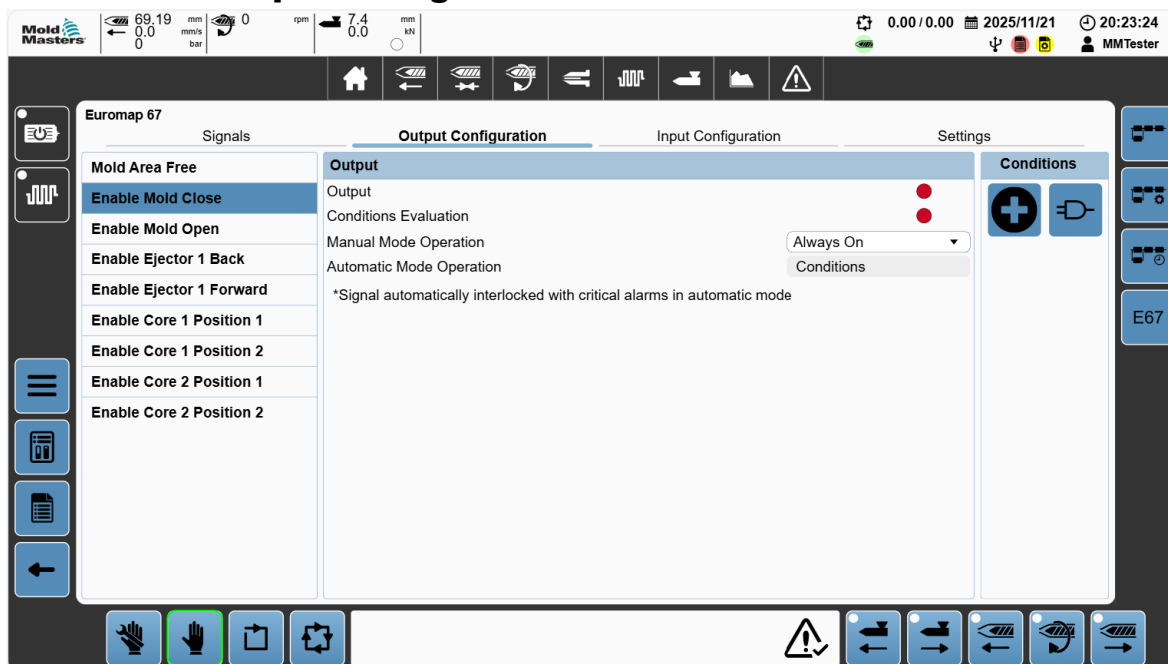

Figure 8-55 E67 screen with the Output configuration tab selected

Configurable E67 outputs are listed in the left panel. Tap the buttons in the Conditions Panel (right panel) to modify a selected output.

Table 8-82 Output Configuration Tab	
Field	Description
Output	Output status Values: Red or off
Conditions Evaluation	Evaluation of the configured conditions If no conditions are configured, it is OK by default. Values: Red or off
Manual Mode Operation	If a specific output for one of the E67 signals is required while outside of automatic mode, you can configure it to always be on, always off, or rely on the configured conditions. Values: <ul style="list-style-type: none"> • Always On • Always Off • Conditions
Automatic Mode Operation	Automatic mode will always use the condition evaluation. If any signals are automatically interlocked with the machine, a message is displayed at the bottom of the Output panel informing this. For example, Enable Mold Close is always interlocked with critical alarms. If there are any active critical alarms, the Enable mold closed signal will be False.

8.21.2 E67 Input Configuration

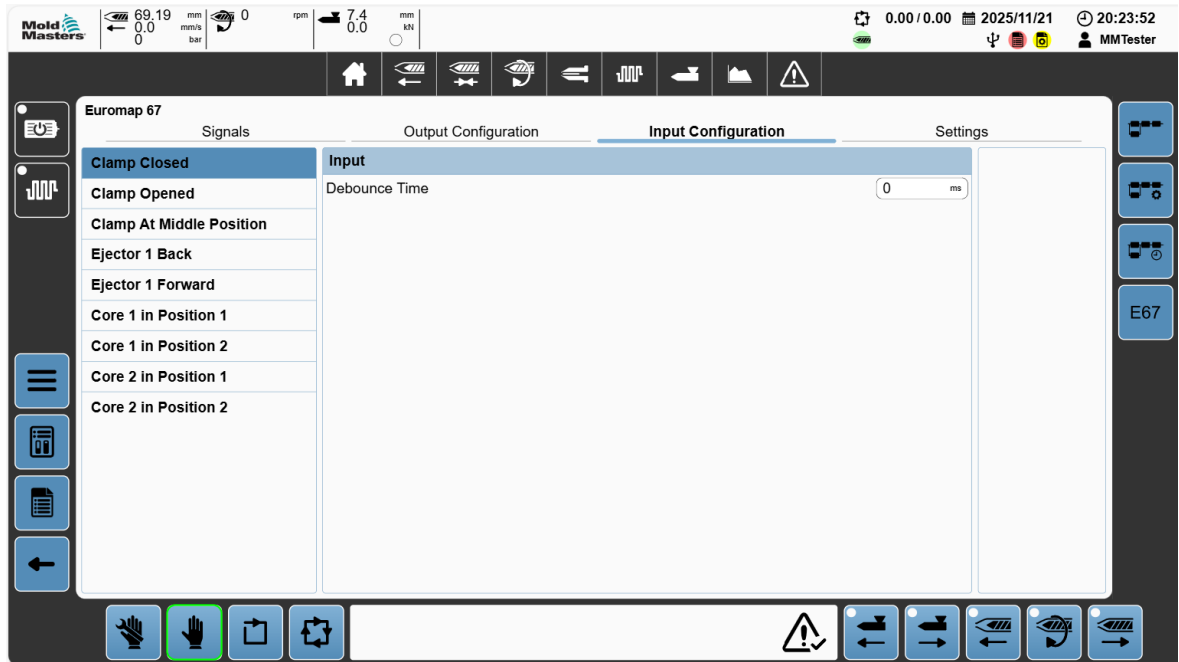

Figure 8-1 E67 Input configuration tab

Table 8-2 input Configuration Tab	
Field	Description
Debounce Time	The debounce sets the time the digital input must be present before the input is recognized.

8.21.3 E67 Settings Tab

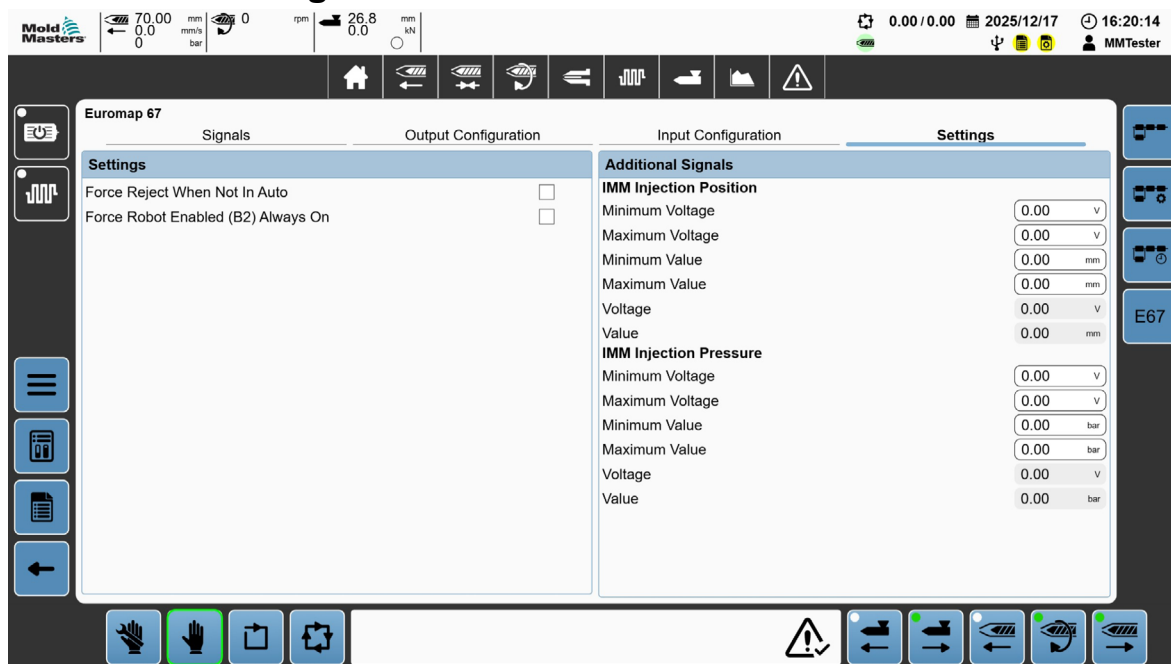

Figure 8-56 E67 screen with the Settings tab selected

Table 8-3 Settings Panel	
Field	Description
Force Reject When Not in Auto	Tap this check box to always force the reject signal to be True when not in automatic mode.
Force Robot Enabled (B2) Always On	Force output B2, Robot Enabled, true when in automatic mode.

Table 8-4 Additional Signals Panel	
Field	Description
IMM Injection Position	
Minimum Voltage	The minimum expected voltage for the analog input, [-10 V to 10 V]. Linearization value for an analog signal from the IMM indicating the position of the IMM injection screw/plunger.
Maximum Voltage	The maximum expected voltage for the analog input, [-10 V to 10 V].
Minimum Value	The IMM injection stroke associated with the Minimum Voltage for linearization [mm]. When the IMM injection position analog input signal is at the minimum voltage, the IMM injection screw/plunger is at the Minimum Value position.

Table 8-4 Additional Signals Panel	
Field	Description
Maximum Value	The IMM injection stroke associated with the Maximum Voltage for linearization [mm]. When the IMM injection position analog input signal is at the maximum voltage, the IMM injection screw/plunger is at the Maximum Value position.
Voltage	Current actual voltage for the IMM injection position analog input.
Value	Actual IMM injection screw/plunger stroke associated with the current analog input voltage.
IMM Injection Pressure	
Minimum Voltage	The minimum expected voltage for the analog input, [-10 V to 10 V]. Linearization value for an analog signal from the IMM indicating the current IMM injection pressure.
Maximum Voltage	The maximum expected voltage for the analog input, [-10 V to 10 V].
Minimum Value	The IMM injection pressure associated with the Minimum Voltage for linearization [bar]. When the IMM injection pressure analog input signal is at the minimum voltage, the recorded IMM injection pressure is at the Minimum Value position.
Maximum Value	The IMM injection pressure associated with the Maximum Voltage for linearization [bar]. When the IMM injection pressure analog input signal is at the maximum voltage, the recorded IMM injection pressure is at the Maximum Value position.
Voltage	Current actual voltage for the IMM injection pressure analog input.
Value	Actual IMM injection pressure associated with the current analog input voltage.

8.22 Files

Tap the following buttons in the order shown to go to the Recipe data screen.



Interfaces with all data files are done through the following data screens; loading, saving, deleting, creating, and renaming recipe and fixed data files. Saving remnant data and exporting user data for troubleshooting and backups are also done here.

8.22.1 Recipe Data

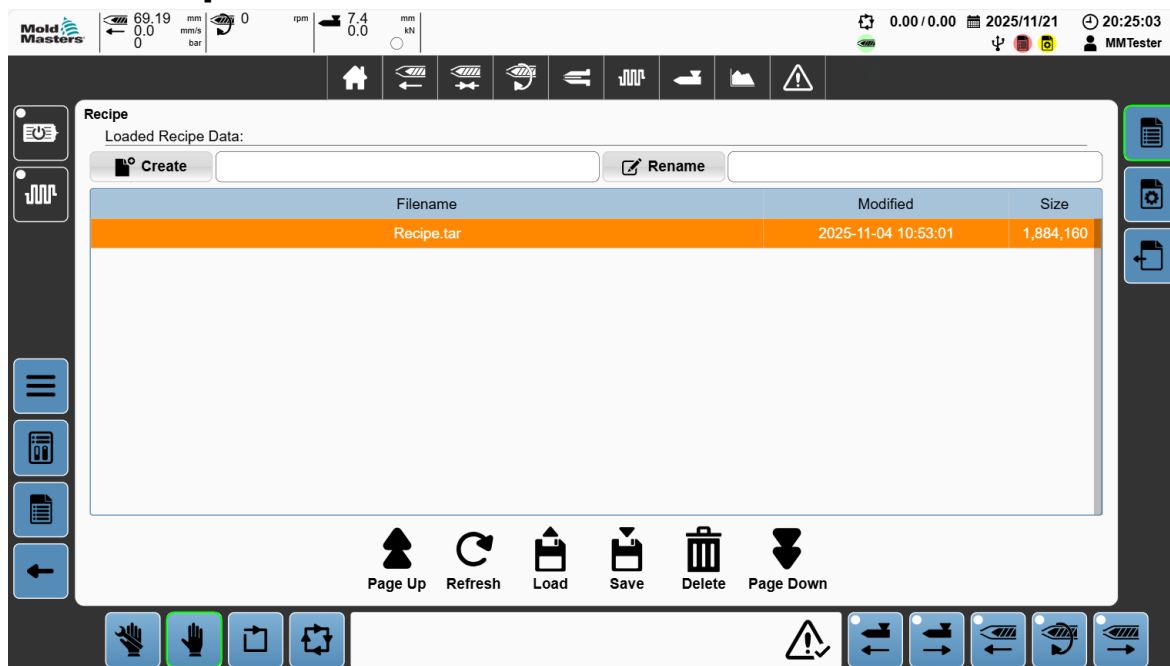

Figure 8-57 Recipe data screen









Table 8-5 Recipe Data Screen	
Field/Button	Description
Loaded Recipe Data: Recipe.tar	Displays the last loaded recipe file
 Create <input type="text"/>	Create File Field To create a file containing all the current recipe values, enter a filename in the text field, and press the Create button.
 Rename <input type="text"/>	Rename File Field To rename a file, enter a filename in the Rename text field, and press the Rename button.
	Displays Recipe Files Select a recipe file to interact with using the other buttons.

Table 8-5 Recipe Data Screen	
Field/Button	Description
 Page Up	Screen Up Button If multiple recipe files are displayed on one screen, use the Screen Up button to scroll up through the recipe file list.
 Refresh	Refresh Button Tap this button to refresh the recipe file list.
 Load	Load Button Tap this button to load the selected recipe file.
 Save	Save Button Tap the Save button to save the selected recipe file.
 Delete	Delete Button Tap the Delete Button to delete the selected recipe file.
 Page Down	Screen Down Button If there are multiple recipe files displayed on one screen, use the Screen Down button to scroll down through the recipe file list.

8.22.2 Fixed Data

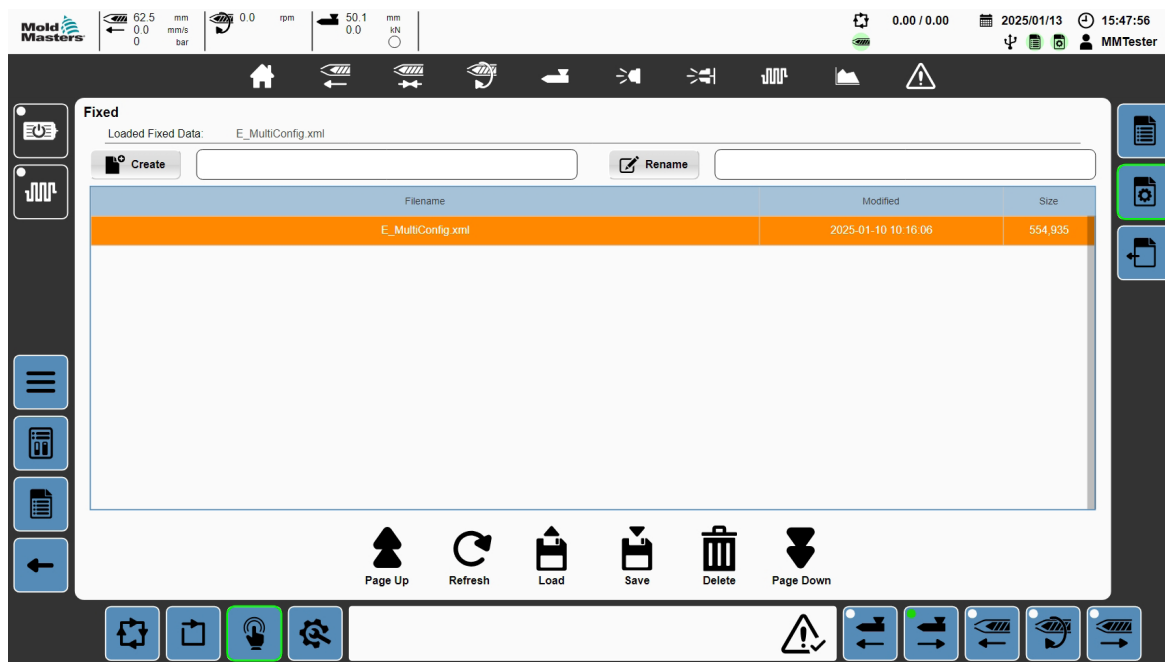

Figure 8-58 Fixed data screen



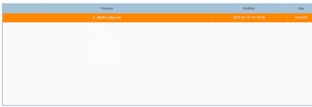





Table 8-6 Fixed Data Screen	
Field/Button	Description
	Displays the last loaded recipe file
 Create <input type="text"/>	Create File Field Enter a filename in the Create File text field, and press the Create button to create a file with that name containing all the current fixed values
 Rename <input type="text"/>	Rename File Field Enter a filename in the Rename text field, and press the Rename button to rename a file.
	Select a fixed file to interact with using the other buttons.
 Page Up	Screen Up Button If multiple recipe files are displayed on one screen, use the Screen Up button to scroll up through the recipe file list.
 Refresh	Refresh Button Tap this button to refresh the recipe file list.

Table 8-6 Fixed Data Screen	
Field/Button	Description
 <p>Load</p>	<p>Load Button</p> <p>Tap this button to load the selected recipe file.</p>
 <p>Save</p>	<p>Save Button</p> <p>Tap the Save button to save the selected recipe file.</p>
 <p>Delete</p>	<p>Delete Button</p> <p>Tap the Delete Button to delete the selected recipe file.</p>
 <p>Page Down</p>	<p>Screen Down Button</p> <p>If there are multiple recipe files displayed on one screen, use the Screen Down button to scroll down through the recipe file list.</p>

8.22.3 User Data

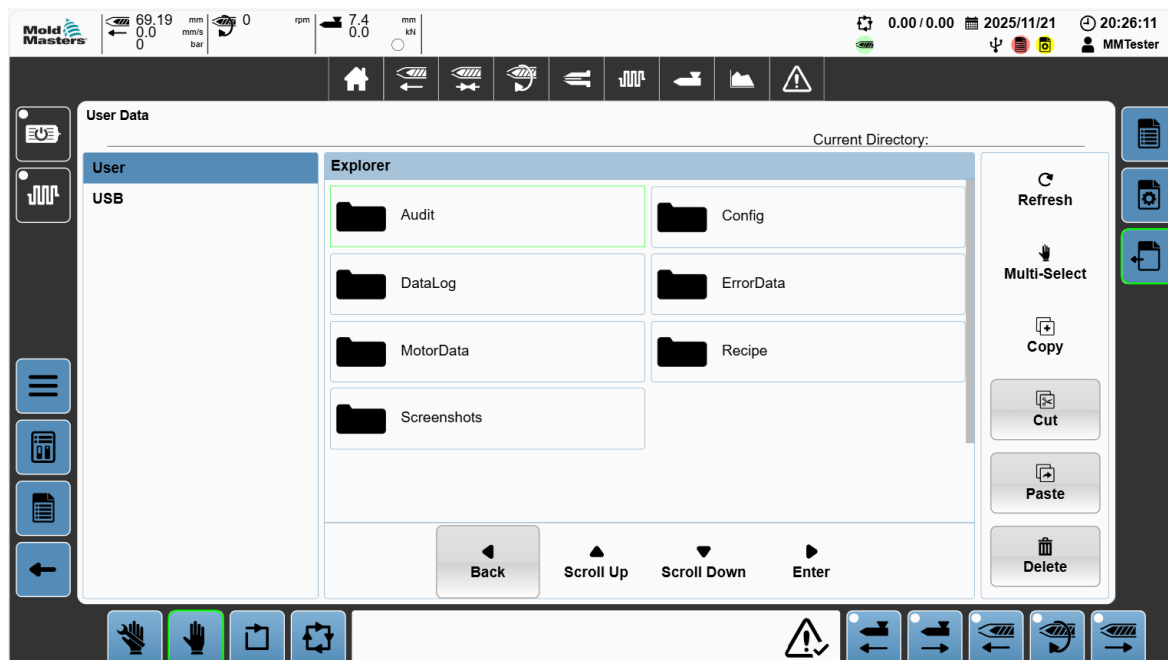

Figure 8-59 User data screen

Table 8-7 User Data Screen	
Field/Button	Description
Explorer	Displays all files/folders in the active directory
Back	Tap the back button to go back to the parent folder
Scroll Up	Tap the scroll Up button to scroll up through the contents of the current folder
Scroll Down	Tap the scroll Down button to scroll down through the contents of the current folder
Enter	Tap the Enter button to open the selected folder
Refresh	Tap the refresh button to refresh the content list.
Multi-Select	Tap the Multi-Select button to enable the selection of the multiple files/folders.
Copy	Tap the copy button to copy the selected files/folders.
Cut	Tap the cut button to cut the selected files/folders.
Paste	Tap the Paste button to paste previously cut or copied files/folders in the current directory
Delete	Tap the Delete button to delete the selected files/folders. All deleted files/folders are permanently deleted and cannot be recovered.

8.23 Documents (PDFs)

Tap the following buttons in the order shown to go to the Documents screen.



8.23.1 Documents (PDFs)

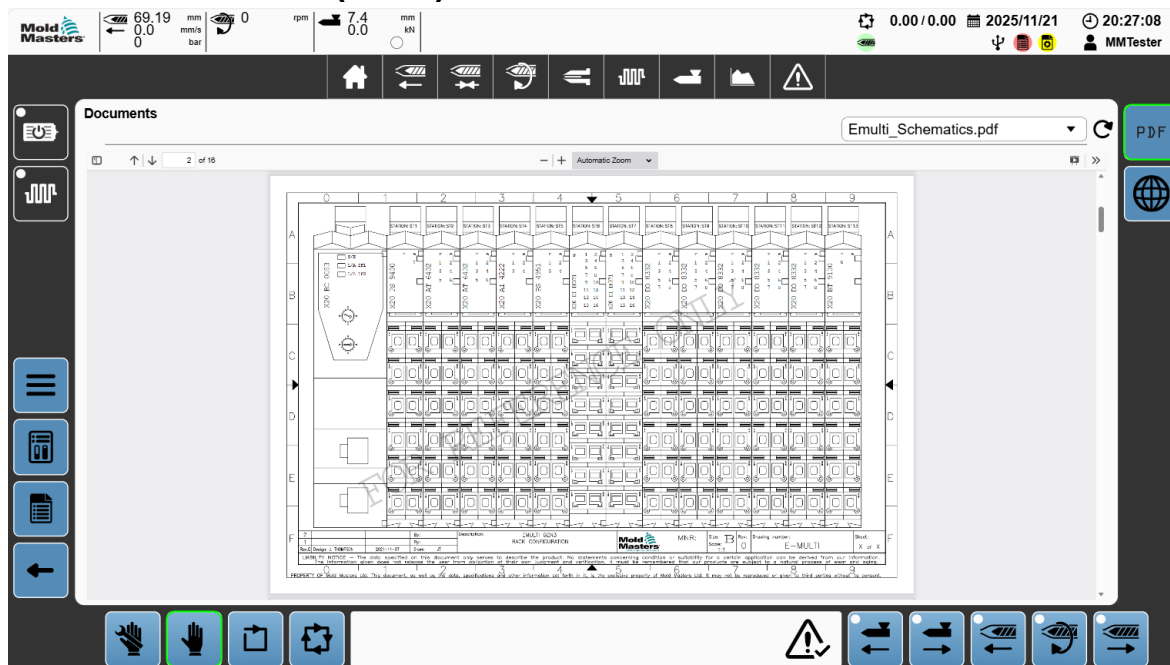

Figure 8-60 Documents screen

Table 8-8 Documents Screen	
Field/Button	Description
	Dropdown list of all available PDF files on the controller Tap a PDF file to view the file.
	Refresh button Tap this button to update the list of PDF files.
	Standard PDF interface control buttons: sidebar display and screen selection
	Standard PDF interface control button: zoom control
	Standard PDF interface control button: presentation mode on/off

8.23.2 Web Screen

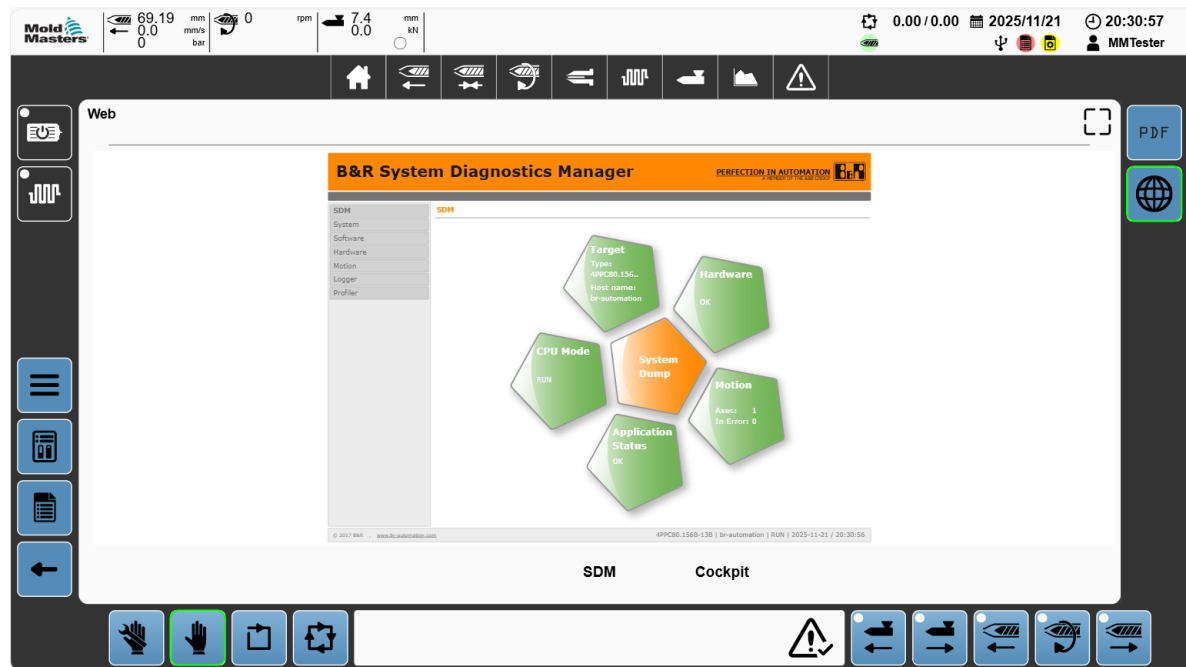

Figure 8-61 Web screen

Table 8-9 Web screen	
Button	Description
	Full screen button Tap the Full screen button to switch to full screen view.
	Tap the Mold-Masters logo to switch from full screen view to the PDF Viewer screen.

8.23.2.1 System Diagnostics Manager (SDM)

To go to the SDM screen, tap the SDM button at the bottom of the web screen.

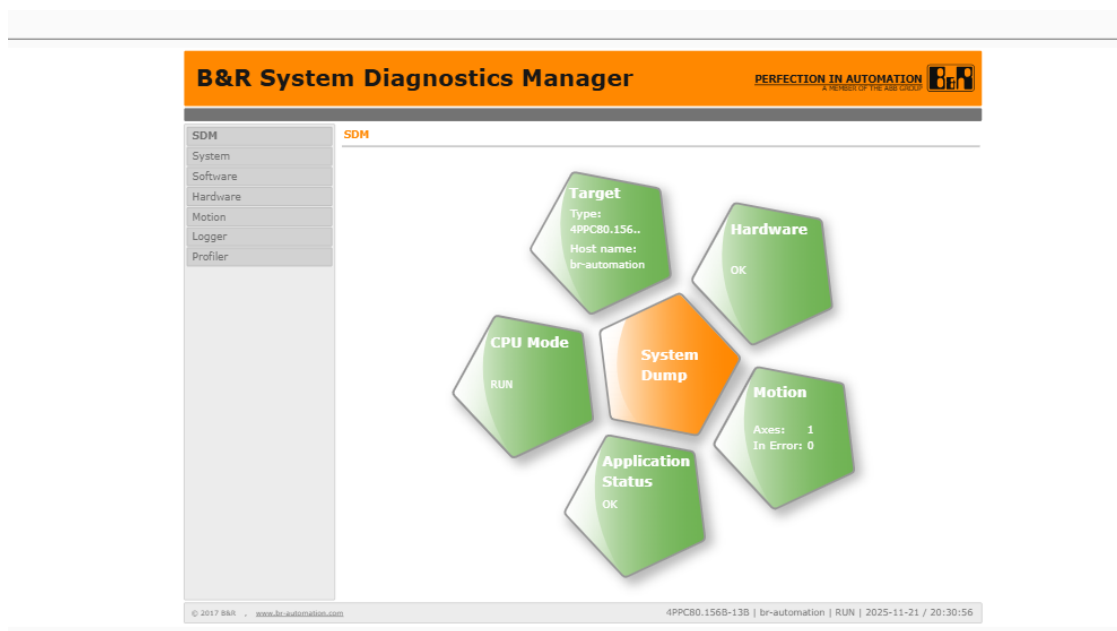

Figure 8-62 SDM interface (Full screen)

Use the SDM interface to diagnose the controller. You can generate a system dump, view hardware and application statuses, and get information on the CPU system.

8.23.2.2 Mapp Cockpit

To go to the Mapp Cockpit, tap the Cockpit button at the bottom of the web screen.

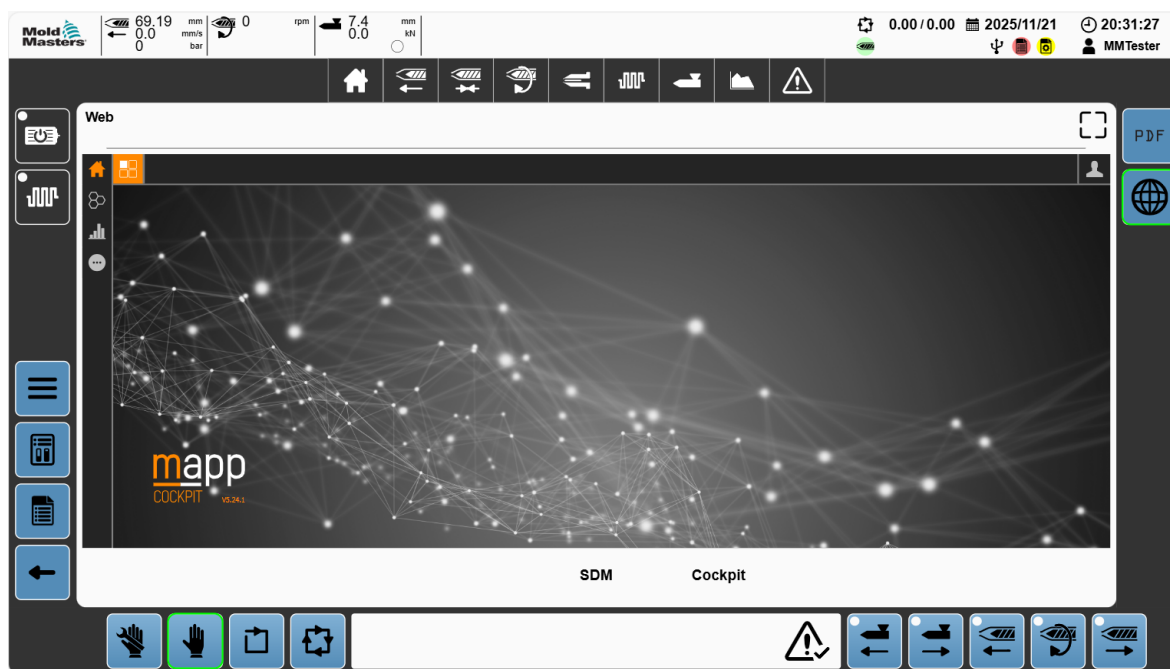

Figure 8-63 Mapp Cockpit screen

The Mapp Cockpit is a web-based HMI application that enables the commissioning of automation components.

The Mapp Cockpit has troubleshooting options and enables additional interaction with automation components. You can:

1. Test the behavior by executing a command of a component
2. Monitor the behavior of a component (observe live values, record a trace, and check logged events).
3. Change the configuration of a component to achieve a desired behavior, and, if necessary, test the behavior again.
4. Permanently save changes to the configuration.
5. Merge the changed configuration with the configuration of the Automation Studio project.

The Mapp Cockpit provides additional troubleshooting functions such as universal trace, which enables a decentralized trace on ACOPOS servo drives and in the PLC.

8.24 Production

Tap the following buttons in the order shown to go to the Production screen.



8.24.1 Production Screen

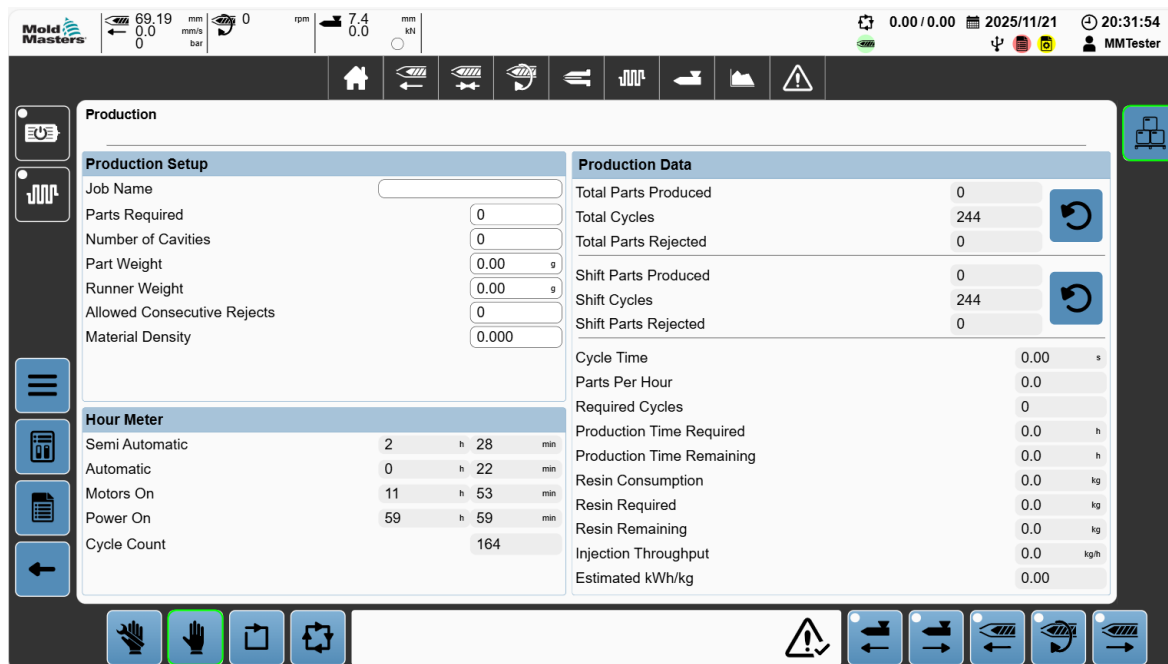



Figure 8-64 Production screen

Table 8-10 Production Setup Panel	
Field	Description
Job Name	User defined name for the current production job. Values: Any text string, 27 characters displayed
Parts Required	Number of produced parts required for current job. Values: Any positive value
Number of Cavities	Number of cavities in mold / number of parts produced per injection cycle. Values: 0 to 65,535
Part Weight	Average weight of finished part. Values: Any positive value in g
Runner Weight	Average weight of runner. Values: Any positive value in g
Allowed Consecutive Rejects	Maximum allowed number of consecutive reject cycles before the E-Multi exits automatic cycling with an error. Values: Any positive value
Material Density	Density of material being used Values: Any positive integer. Values: Any negative value up to maximum positive value

Table 8-11 Hour Meter Panel	
Field	Description
Semi Automatic	Hours spent in semi-automatic mode of operation
Automatic	Hours spent in full automatic mode of operation Full automatic is not normally available on the E-Multi.
Motors On	Hours spent with the motors enabled
Power On	Hours spent with the power enabled
Cycle Count	Current E-Multi cycle count

Table 8-12 Production Data Panel	
Field/Button	Description
Total Parts Produced	Total number of parts produced by the E-Multi
Total Cycles	Total number of production cycles of this E-Multi
	Reset Totals button Tap the Resets Totals button to reset the total parts produced and total cycles to 0.
Shift Parts Produced	Total number of parts produced on current shift
Shift Cycles	Total number of production cycles on current shift
	Reset Shifts button Tap the Reset Shifts button to reset the shift parts produced and shift cycles to 0.
Cycle Time	Current cycle time
Parts Per Hour	Average number of parts produced per hour of cycling
Required Cycles	The number of machine cycles required to produce the parts required. Equal to parts required / number of cavities
Production Time Required	The amount of time to produce the parts required. Equal to required cycles * cycle time
Production Time Remaining	The amount of time remaining to finish the production run
Resin Consumption	The weight of resin already consumed during the current production run
Resin Required	The weight of resin required to make the parts required for current production run
Resin Remaining	The weight of resin required for remaining production
Injection Throughput	The weight of resin consumed per hour
Estimated kWh/kg	The estimated energy in kWh required to process one kg of material

8.25 Wait Timers

Tap the following buttons in the order shown to go to the Wait Timers screen.

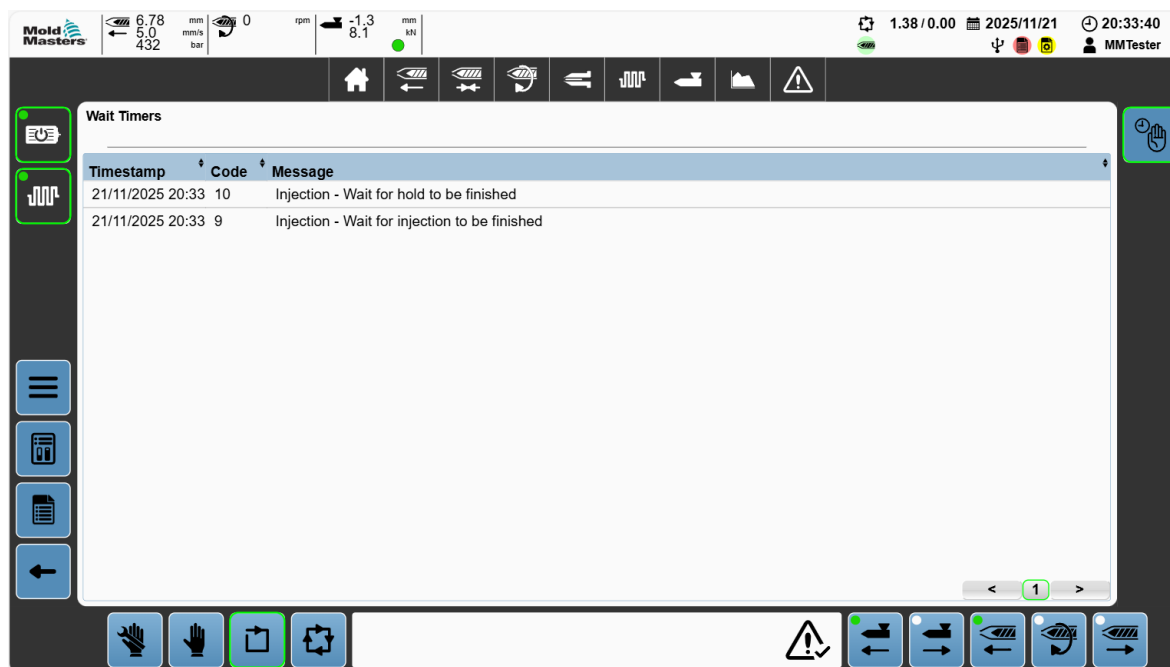

Figure 8-65 Mold coding screen

Table 8-13 Wait Timers Screen											
Field/Button	Description										
<table border="1"> <thead> <tr> <th>Timestamp</th> <th>Code</th> <th>Message</th> </tr> </thead> <tbody> <tr> <td>07/12/2024 18:44:27</td> <td>184</td> <td>Auto Sequence - Wait for timer</td> </tr> <tr> <td>07/12/2024 18:43:58</td> <td>34</td> <td>Auto Sequence - Wait for cycle to finish</td> </tr> </tbody> </table>	Timestamp	Code	Message	07/12/2024 18:44:27	184	Auto Sequence - Wait for timer	07/12/2024 18:43:58	34	Auto Sequence - Wait for cycle to finish	<p>Displays all active wait points (conditions a program is waiting for to continue)</p> <p>Alarms can be sorted by timestamp, code, and message by tapping their header section.</p>	
Timestamp	Code	Message									
07/12/2024 18:44:27	184	Auto Sequence - Wait for timer									
07/12/2024 18:43:58	34	Auto Sequence - Wait for cycle to finish									
<p>< ></p>	<p>Pagination buttons</p> <p>Left arrow (previous), Right arrow (next)</p> <p>If there are more wait timers than the screen can display, you can use the previous, next, and screen index buttons to navigate to the wait timers.</p>										



8.26 Schedule

Tap the following buttons in the order shown to go to the Schedule screen.



Figure 8-67 Schedule screen

Table 8-14 Schedule Screen	
Field/Button	Description
	Week schedule
	<p>Add event button</p> <p>Tap the Add event button to add an event to the schedule for that day. Events can be set for multiple days.</p>
	<p>Green - Start event for barrel heats</p> <p>Red - Stop event for barrel heats</p> <p>Tap the event to modify or delete the event.</p>
	<p>Green - Start event for motors</p> <p>Red - Stop event for motors</p> <p>Tap the event to modify or delete the event.</p>
	<p>Green - Start event for digital output</p> <p>Red - Stop event for digital output</p> <p>The digital output number is indicated.</p> <p>Tap the event to modify or delete the event.</p>

Table 8-14 Schedule Screen	
Field/Button	Description
	Green - Start event for integrated hot runner controller
	Red - Stop event for integrated hot runner controller Tap the event to modify or delete the event.

When you tap an event, the add/modify dialog box is displayed:

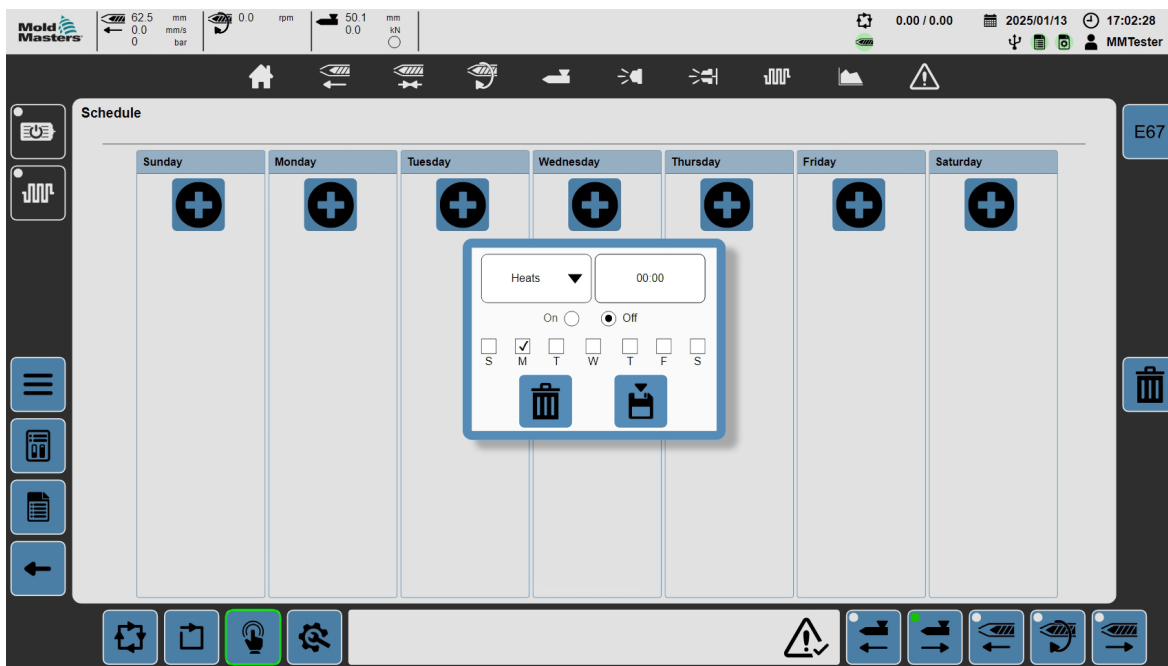

Figure 8-68 Schedule-Screen Dialog Box

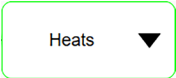
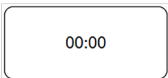



Table 8-15 Schedule-Screen Dialog Box	
Field/Button	Description
	Event function Values: Heats, Motors, HRC, Output 1, Output 2, Output 3, Output 4 Tap this button to select the event function.
	Time entry Values: Any time Tap this box to enter a time for the event.
	On - Tap the On option button to enable the event. Off - Tap the Off option button to disable the event.

Table 8-15 Schedule-Screen Dialog Box	
Field/Button	Description
<input type="checkbox"/> S <input checked="" type="checkbox"/> M <input type="checkbox"/> T <input type="checkbox"/> W <input type="checkbox"/> T <input type="checkbox"/> F <input type="checkbox"/> S	Day(s) of the week for the event Values: S (Sunday), M (Monday), T (Tuesday), W (Wednesday), T (Thursday), F (Friday), S (Saturday)
	Cancel/Delete button Tap the Cancel/Delete button to cancel the adding of a new event or to delete an existing event.
	Save button Tap the Save button to save the new or modified event.

8.27 Change Log

Tap the following buttons in the order shown to go to the Change Log screen.

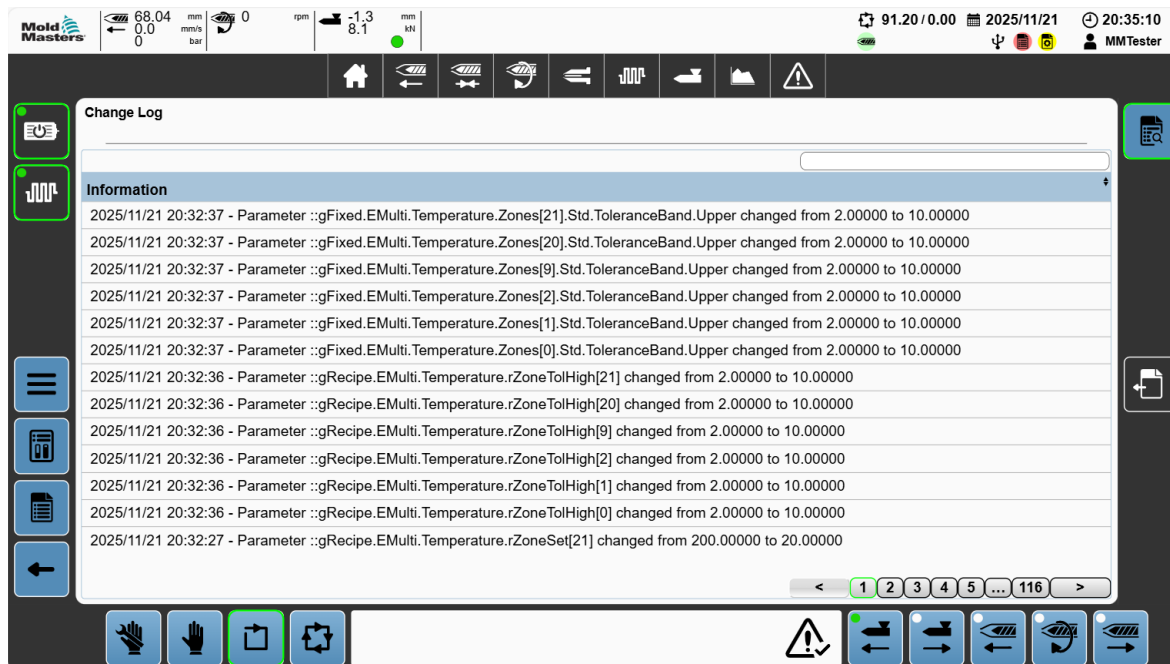

Figure 8-69 Change log screen

Table 8-16 Change Log Screen	
Field/Button	Description
	Information filter Enter information into this box to filter the list of entries so that the list only contains entries with the entered information.
	List of all recorded changes Changes are sorted by date and time.
	Pagination buttons Left arrow (previous), right arrow (next) If there are more entries that the screen can display, use the previous, next, and screen index buttons to navigate to the other entries.
	Export change log button Tap the Export change log button to export the change log to the user data as a text file. To delete the exported text file or copy the file to a USB drive, see section “8.26.3 User Data” on screen 8-144.

8.28 Log Book

Tap the following buttons in the order shown to go to the Log Book screen.

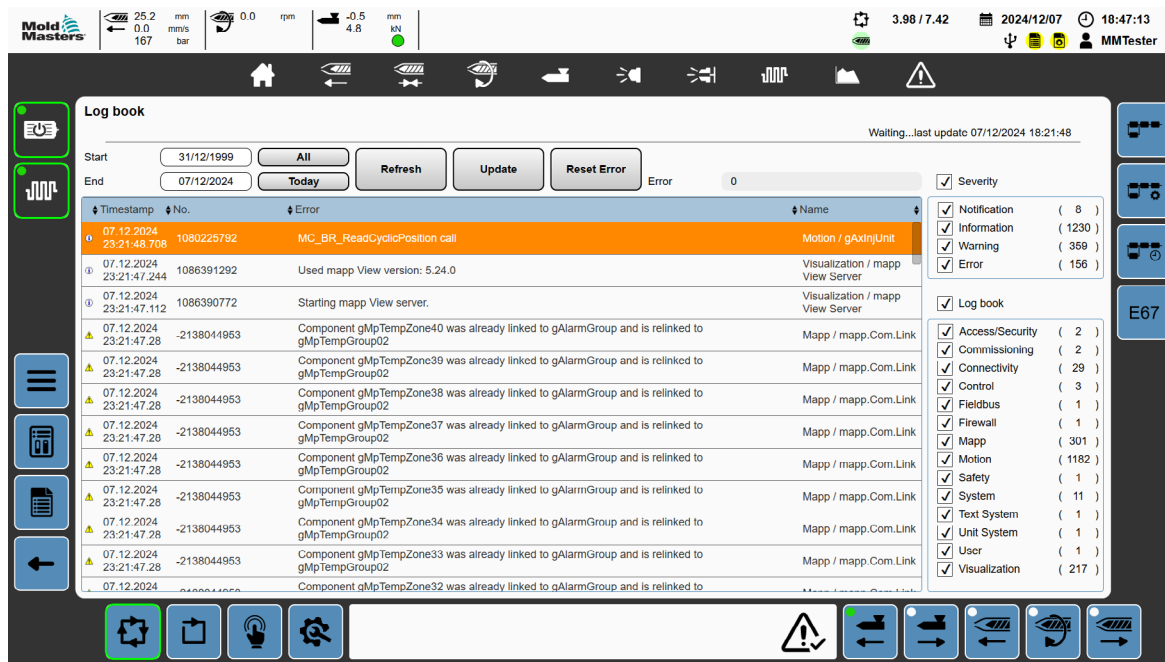

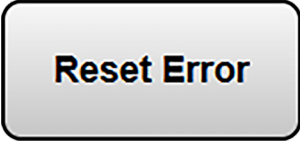
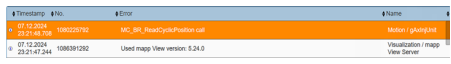

Figure 8-70 Log book screen

Table 8-17 Log Book Screen	
Field/Button	Description
Start <input type="text" value="31/12/1999"/>	Start date for displaying log book entries
End <input type="text" value="07/12/2024"/>	End date for displaying log book entries
All	Select All button Tap the All button to set the Start and End dates to include all log book entries.
Today	Select Today button Tap the Today button to set the Start and End dates to include all log book entries for today only.
Refresh	Refresh button Tap the Refresh button to refresh the list of log book entries.

Table 8-17 Log Book Screen	
Field/Button	Description
	<p>Update button</p> <p>Tap the Update button to update the list of log entries according the type, severity, and date selections.</p>
	<p>Reset Error button</p> <p>Tap the Reset Error button to reset errors from reading the log book.</p>
<p>Error 0</p>	<p>Error code for log book access functions</p>
	<p>Log book entries</p> <p>Tap the timestamp, ID number, error message, or log book name header to sort the log book entries by the header.</p>
<p><input checked="" type="checkbox"/> Severity</p>	<p>Severity check box</p> <p>Tap the Severity check box to select entries of all severity levels.</p>
<p><input checked="" type="checkbox"/> Notification (8)</p> <p><input checked="" type="checkbox"/> Information (1230)</p> <p><input checked="" type="checkbox"/> Warning (359)</p> <p><input checked="" type="checkbox"/> Error (156)</p>	<p>Severity level check boxes</p> <ul style="list-style-type: none"> • Notification • Information • Warning • Error <p>The number in parentheses indicates the number of log book entries having that severity level.</p>
<p><input checked="" type="checkbox"/> Log book</p>	<p>Log-book check box</p> <p>Tap the Log book check box to select the entries of all log books.</p>

8.29 Machine Information

Tap the following buttons in the order shown to go to the Machine Info screen.

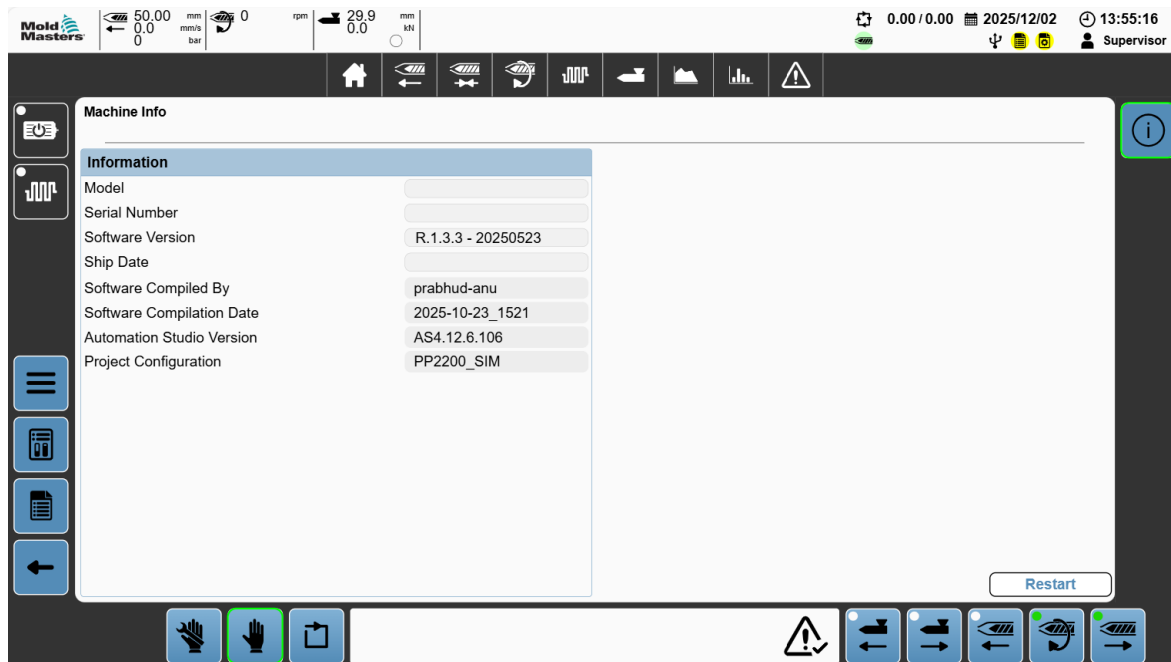

Figure 8-71 Machine Information screen

Table 8-18 Machine Information Screen	
Field/Button	Description
Model	Model type of the E-Multi. Values: Any string
Serial number	Serial number of the E-Multi. Values: Any string
Software Version	Release version of the software.
Ship date	The date the E-Multi was shipped from Mold-Masters. Values: Any string
Software Compiled By	Software Compiled By displays the name of the compiler.
Software Compilation Date	Software compilation date displays the compilation date.
Automation Studio Version	Automation Studio Version displays the version of automation studio
Project Configuration	Project Configuration displays the project configuration

8.30 Data Logger

Tap the following buttons in the order shown to go to the Data Logger screen.



8.30.1 Data Logger Screen

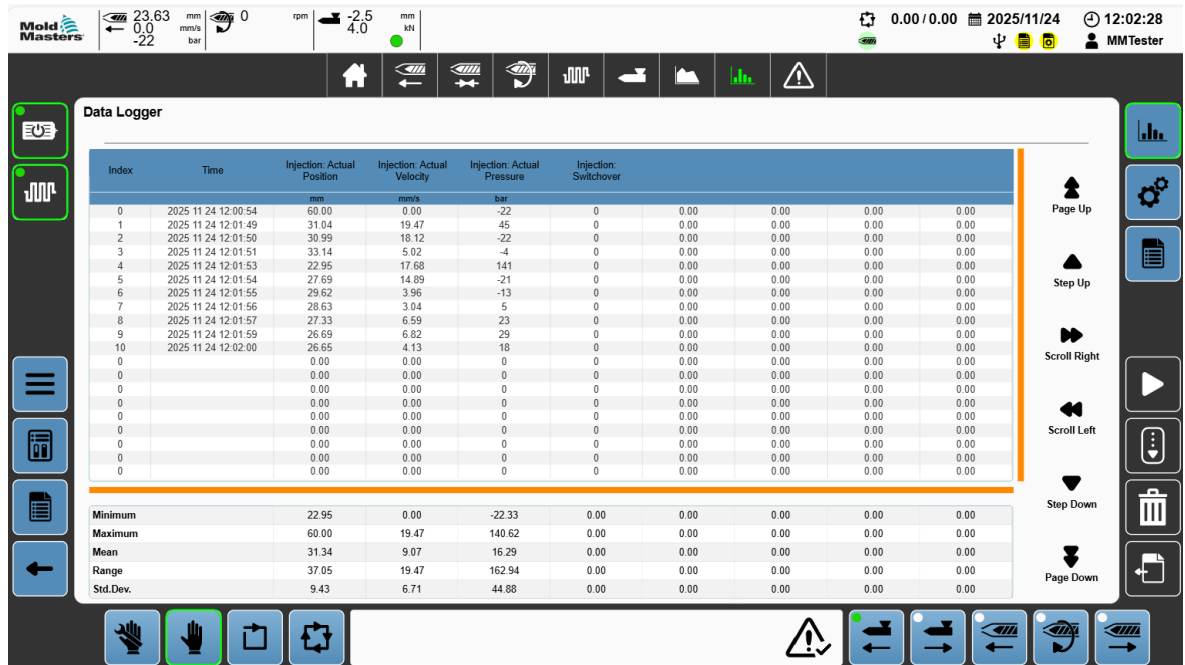

Figure 8-72 Data logger screen

Table 8-19 Data Logger Screen					
Field/Button			Description		
Index	Time				A list of values recorded over time for the selected process variables
0		0.00	0.00	0.00	
0		0.00	0.00	0.00	
0		0.00	0.00	0.00	
0		0.00	0.00	0.00	
0		0.00	0.00	0.00	

Table 8-20 Statistics Panel of the Data Logger Screen	
Field	Description
Minimum	Minimum value recorded
Maximum	Maximum value recorded
Mean	Mean (average) for the column
Range	Range between the maximum and the minimum value for the column
Std. Dev.	Standard deviation

8.30.2 Data Logger Configuration

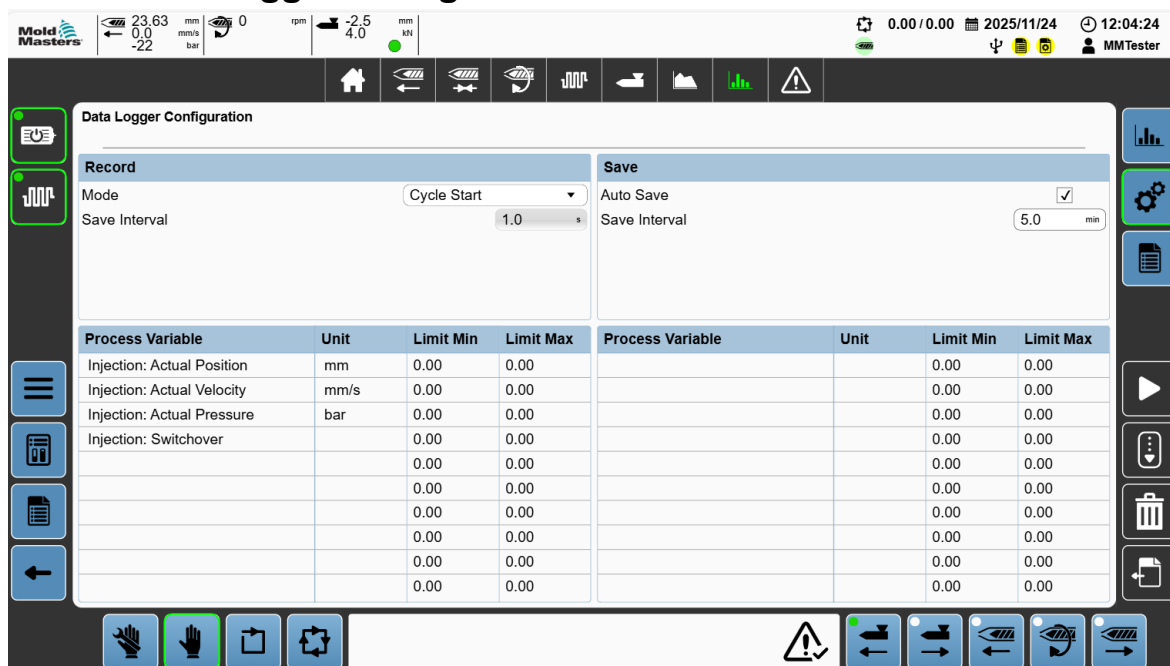

Figure 8-73 Data-logger configuration screen

Table 8-21 Data-Logger Configuration Screen	
Field	Description
Record	
Mode	Data sampling can be performed on a time interval or after a trigger. Values: Time, Cycle Start
Save Interval	Time interval between data sampling Values: Any positive value Note: Can only be changed when the Mode is set to Time
Save	
Auto Save	When set to Yes, the collected data is saved as a CSV file to local memory or a USB drive after each save interval. Values: No, Yes
Save Interval	Time interval between automatic saving of the collection data to a CSV file values. Values: Any positive value
Process Variable	Tap anywhere in this area to open the PV selection dialog.
Unit	Associated units for the selected process variable

Table 8-21 Data-Logger Configuration Screen			
Field		Description	
Process Variable	Unit	Limit Min	Limit Max
Injection: Switchover Position	mm	0.00	0.00
Injection: Peak Boost Velocity	mm/s	0.00	0.00
Limit Max	Minimum: Minimum value recorded during the trace Values: -1,000,000 to 1,000,000 Maximum value recorded during the trace Values: -1,000,000 to 1,000,000		

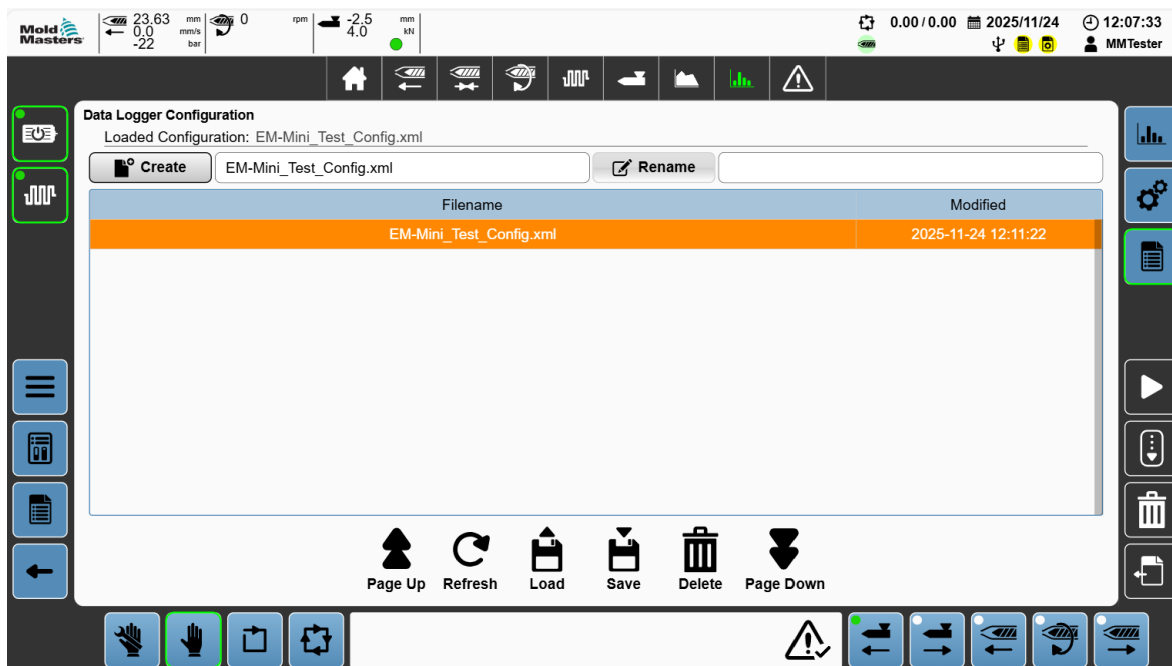









Figure 8-74 File interface screen

You can use the file interface screen to save the current configuration to the drive or to load a previously saved configuration.

Table 8-22 File Interface Screen	
Field/Button	Description
Loaded Recipe Data: Recipe.tar	Displays the last loaded recipe file
Create <input type="text"/>	Create File Field To create a file containing all the current recipe values, enter a filename in the text field, and press the Create button.
Rename <input type="text"/>	Rename File Field To rename a file, enter a filename in the Rename text field, and press the Rename button.

Table 8-22 File Interface Screen	
Field/Button	Description
	<p>Displays Recipe Files</p> <p>Select a recipe file to interact with using the other buttons.</p>
 Page Up	<p>Screen Up Button</p> <p>If multiple recipe files are displayed on one screen, use the Screen Up button to scroll up through the recipe file list.</p>
 Refresh	<p>Refresh Button</p> <p>Tap this button to refresh the recipe file list.</p>
 Load	<p>Load Button</p> <p>Tap this button to load the selected recipe file.</p>
 Save	<p>Save Button</p> <p>Tap the Save button to save the selected recipe file.</p>
 Delete	<p>Delete Button</p> <p>Tap the Delete Button to delete the selected recipe file.</p>
 Page Down	<p>Screen Down Button</p> <p>If there are multiple recipe files displayed on one screen, use the Screen Down button to scroll down through the recipe file list.</p>

8.31 Cycle Information

Tap the following buttons in the order shown to go to the Cycle Information screen.

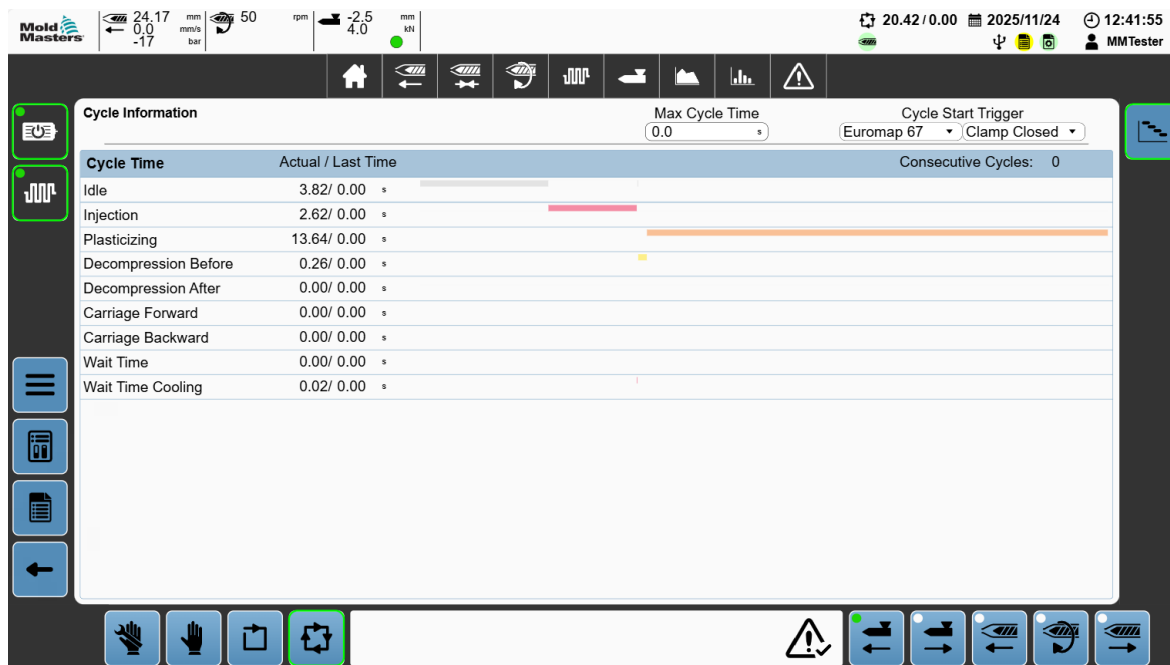

Figure 8-75 Cycle information screen

Table 8-23 Cycle Information	
Field	Description
Max Cycle Time	Maximum allowed cycle time before cycling quits with an alarm Values: Any positive value To disable the limit, set the Max Cycle Time to 0.0 seconds.
Cycle Start Trigger Euromap 67 Clamp Closed	Cycle Start Trigger Values: <ul style="list-style-type: none"> • Euromap 67 • E-Multi, M-Ax • Digital Input • E-Drive Tap the left dropdown list box to select the primary component to use for cycle start triggering.

Table 8-23 Cycle Information																															
Field	Description																														
<p>Cycle Start Trigger</p> <p>Euromap 67 ▼ Clamp Closed ▼</p>	<p>Cycle Start Trigger</p> <p>Values:</p> <p>Euromap 67:</p> <ul style="list-style-type: none"> Clamp Closed, Clamp Open, Ejector 1 Forward, Ejector 1 Back <p>E-Multi:</p> <ul style="list-style-type: none"> Injection Start Carriage Forward Carriage Backward Plasticizing Start <p>M-Ax:</p> <ul style="list-style-type: none"> M-Ax1 M-Ax2 M-Ax3 M-Ax4 M-Ax5 M-Ax6 <p>Digital Input:</p> <ul style="list-style-type: none"> DI 1 through DI 16 <p>E-Drive:</p> <ul style="list-style-type: none"> E-Drive 1 E-Drive 2 <p>Tap the right dropdown list box to select the specific condition to trigger a new cycle recording.</p>																														
<p>Consecutive Cycles: 223</p>	<p>Consecutive Cycles</p> <p>Current count of consecutive automatic cycles Resets when the E-Multi exits automatic mode</p>																														
<table border="1"> <thead> <tr> <th>Cycle Time</th> <th>Actual / Last Time</th> <th>Consecutive Cycles: 223</th> </tr> </thead> <tbody> <tr> <td>Idle</td> <td>0.02 / 0.10</td> <td></td> </tr> <tr> <td>Injection</td> <td>2.62 / 3.20</td> <td></td> </tr> <tr> <td>Plasticizing</td> <td>0.00 / 0.00</td> <td></td> </tr> <tr> <td>Decompression Before</td> <td>0.00 / 0.32</td> <td></td> </tr> <tr> <td>Decompression After</td> <td>0.00 / 0.24</td> <td></td> </tr> <tr> <td>Carriage Forward</td> <td>0.04 / 1.20</td> <td></td> </tr> <tr> <td>Carriage Backward</td> <td>0.00 / 1.06</td> <td></td> </tr> <tr> <td>Heat Time</td> <td>0.00 / 1.00</td> <td></td> </tr> <tr> <td>Heat Time Cooling</td> <td>0.00 / 0.02</td> <td></td> </tr> </tbody> </table>	Cycle Time	Actual / Last Time	Consecutive Cycles: 223	Idle	0.02 / 0.10		Injection	2.62 / 3.20		Plasticizing	0.00 / 0.00		Decompression Before	0.00 / 0.32		Decompression After	0.00 / 0.24		Carriage Forward	0.04 / 1.20		Carriage Backward	0.00 / 1.06		Heat Time	0.00 / 1.00		Heat Time Cooling	0.00 / 0.02		<p>List of current and previous cycles</p> <p>Displays a colour bar for each cycle component representing the portion of the cycle each component required</p> <p>A pale shade of a colour is used for the current cycle while a darker shade of the same colour is used for the previous cycle uses.</p>
Cycle Time	Actual / Last Time	Consecutive Cycles: 223																													
Idle	0.02 / 0.10																														
Injection	2.62 / 3.20																														
Plasticizing	0.00 / 0.00																														
Decompression Before	0.00 / 0.32																														
Decompression After	0.00 / 0.24																														
Carriage Forward	0.04 / 1.20																														
Carriage Backward	0.00 / 1.06																														
Heat Time	0.00 / 1.00																														
Heat Time Cooling	0.00 / 0.02																														

8.32 Material Data

Tap the following buttons in the order shown to go to the Material Data screen.

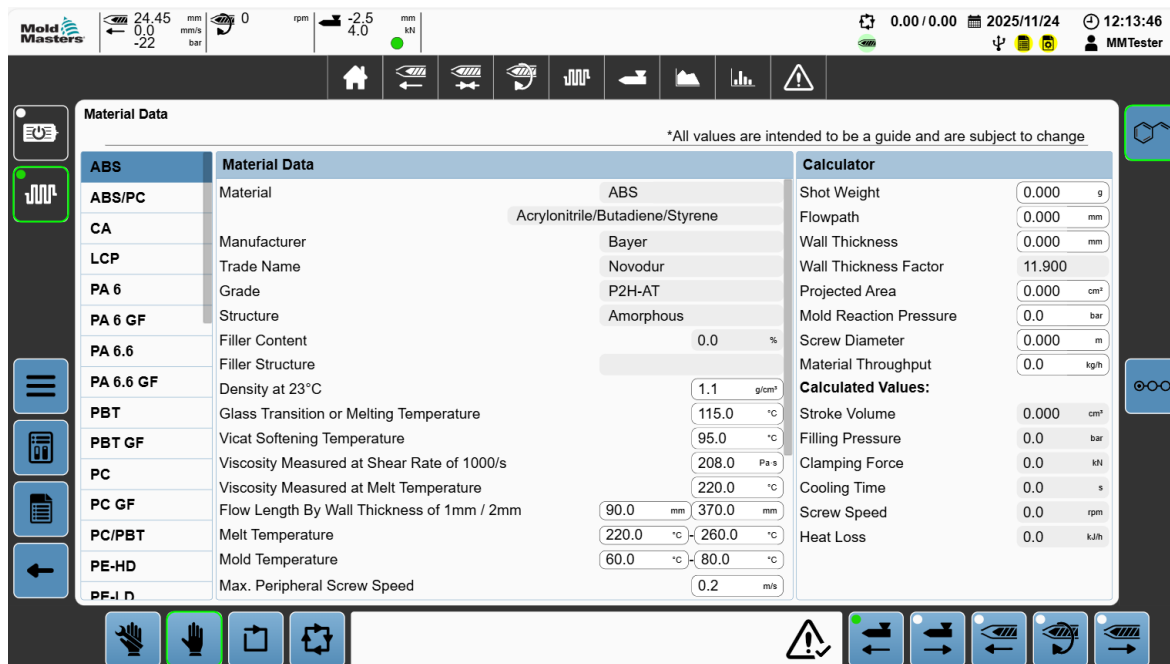

Figure 8-76 Material data screen

Tap a material in the left panel to see the material's data.

Table 8-24 Material Data Panel	
Field	Description
<p>Material: PET GF Polyethylene Terephthalate Glass Fibre</p> <p>Manufacturer: Dupont</p> <p>Trade Name: Rynite</p> <p>Grade: 530 NC-10</p> <p>Structure: Semi Crystalline</p> <p>Filler Content: 30.0 %</p> <p>Filler Structure: Glass Fibre</p>	Origin information for the selected material
<p>Density at 23°C: 1.6 g/cm³</p> <p>Glass Transition or Melting Temperature: 254.0 °C</p> <p>Vicat Softening Temperature: 228.0 °C</p> <p>Viscosity Measured at Shear Rate of 1000/s: 168.0 Pa s</p> <p>Viscosity Measured at Melt Temperature: 280.0 °C</p> <p>Flow Length By Wall Thickness of 1mm / 2mm: 100.0 mm / 420.0 mm</p> <p>Melt Temperature: 280.0 °C / 300.0 °C</p> <p>Mold Temperature: 110.0 °C / 110.0 °C</p> <p>Max. Peripheral Screw Speed: 0.6 mm</p>	<p>Material data</p> <p>Values: Any numeric value</p> <p>Tap a field to modify the values used by the calculator.</p>

Table 8-25 Calculator Panel	
Field	Description
Shot Weight	Weight of plastic injected into mold each cycle Values: Any negative value up to maximum positive value in g
Flowpath	Length of plastic flow from the sprue to the edge of the part Values: Values: Any negative value up to maximum positive value in mm
Wall Thickness	Thickness of part wall Values: Values: Any negative value up to maximum positive value in mm
Wall Thickness Factor	Multiplication factor used in the calculation of the filling pressure based on the wall thickness
Projected Area	Total of the projected areas of the cavities and runners in relation to the parting surface Values: Any negative value up to maximum positive value in cm ²
Mold Reaction Pressure	Cavity pressure inside the mold Values: Any negative value up to maximum positive value in bar
Screw Diameter	Diameter of the injection screw Values: Any negative value up to maximum positive value in m
Material Throughput	Weight of plastic resin processed by the machine per hour Values: Any negative value up to maximum positive value in kg/h
Calculated Values	
Stroke Volume	Volume of material required (shot size)
Filling Pressure	Approximate injection pressure required
Clamping Force	Clamping force required
Cooling Time	Minimum part cooling time after the injection and hold process is completed
Screw Speed	Rotational screw speed during plasticizing
Heat Loss	The heat received by the system multiplied by the material throughput

8.33 Timers

Tap the following buttons in the order shown to go to the Timers screen.

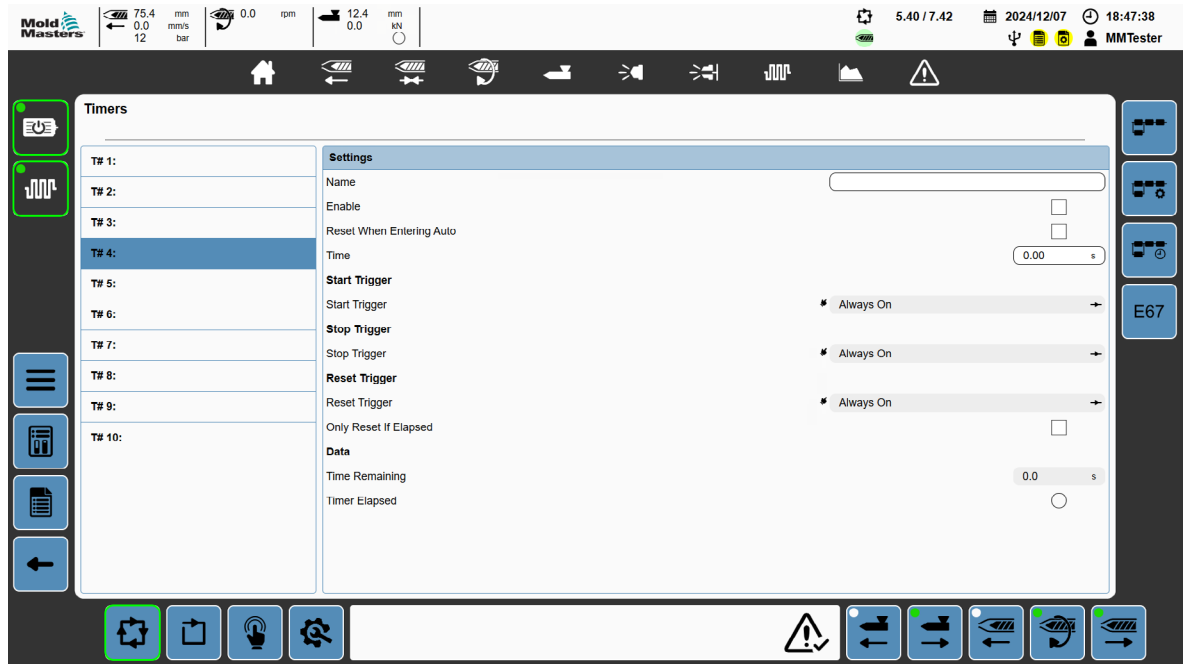

Figure 8-78 Timers screen

Tap a timer in the left panel to see the timer’s settings

Table 8-26 Settings Panel	
Field	Description
Name	Enter the name for the Timer
Enable	Tap this check box to enable the timer.
Reset When Entering Auto	Tap this check box to have the timer reset when the mode of operation changes from manual, setup, or configuration to automatic. The timer stops counting down, the Time Remaining is reset to full, set delay time, and returns to idle to wait for the start trigger.
Time	Set delay time Values: 0 s to 4,294,967 s
Start Trigger	
Start Trigger	Trigger condition to start the timer counting Once the Time Remaining equals zero, the Timer Elapsed flag is set.

Table 8-26 Settings Panel	
Field	Description
Stop Trigger	
Stop Trigger	Trigger condition to stop the timer counting down and return to idle The stop trigger does not cause the timer to reset.
Reset Trigger	
Reset Trigger	Trigger for the timer to stop counting down, reset Time Remaining to the full, set delay time, and return to idle to wait for the start trigger
Only Reset If Elapsed	Tap this check box to have the reset trigger processed only if the time remaining is zero.
Data	
Time Remaining	Remaining delay time before the timer has elapsed
Timer Elapsed	Values: Off or red If red, the timer delay is complete.

8.34 Counters

Tap the following buttons in the order shown to go to the Valve Gates screen.

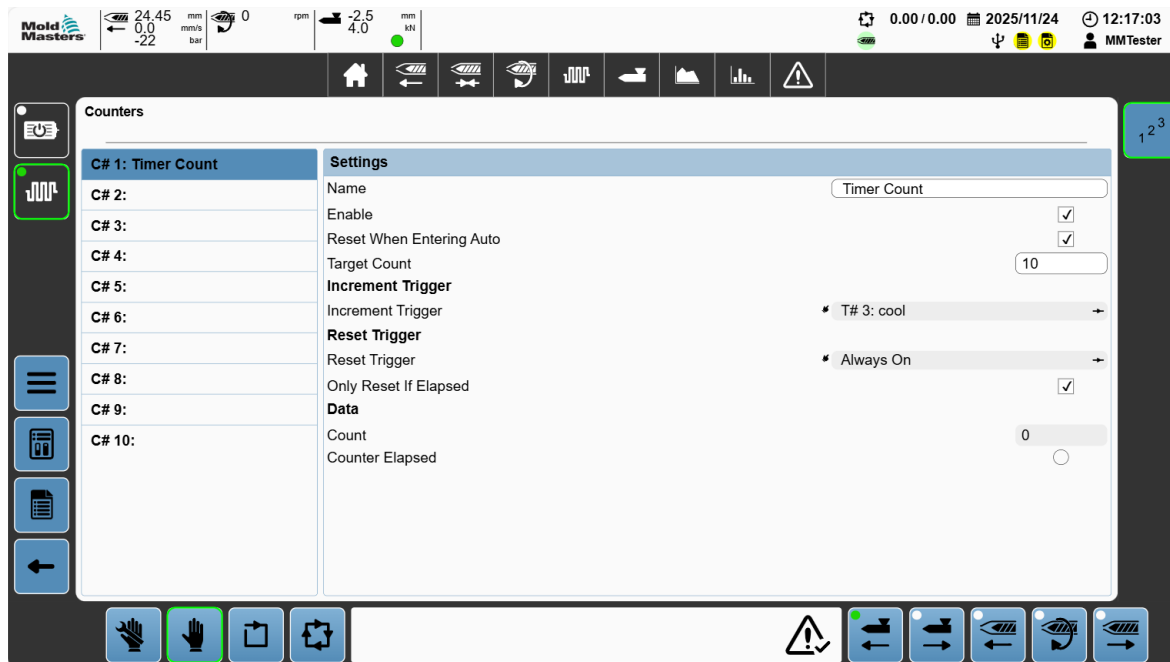

Figure 8-79 Counters screen

Tap a counter in the left panel to see the counter's settings.

Table 8-27 Settings Panel	
Field	Description
Name	Enter the name for the counter
Enable	Tap this check box to enable the timer.
Reset When Entering Auto	Tap this check box to have the counter reset when the mode of operation changes from manual, setup, or configuration to automatic. The Counter stops counting, the Count is reset to zero, and returns to idle to wait for the start trigger.
Target Count	Set number of start trigger events that need to be counted before the count is complete Values: Any positive value
Increment Trigger	
Increment Trigger	Trigger condition to start the counter Once the Count equals the Target Count, the Counter Elapsed flag is set.
Reset Trigger	

Table 8-27 Settings Panel	
Field	Description
Reset Trigger	Trigger for the counter to stop counting, reset the Count to 0, and return to idle to wait for the start trigger
Only Reset If Elapsed	Tap this check box to have the reset trigger processed only if the Count equals the Target Count.
Data	
Count	Actual number of start trigger events counted
Counter Elapsed	Values: Off or red If red, the count is complete.

8.35 Interface Overview

Tap the following buttons in the order shown to go to the Interface Overview screen.

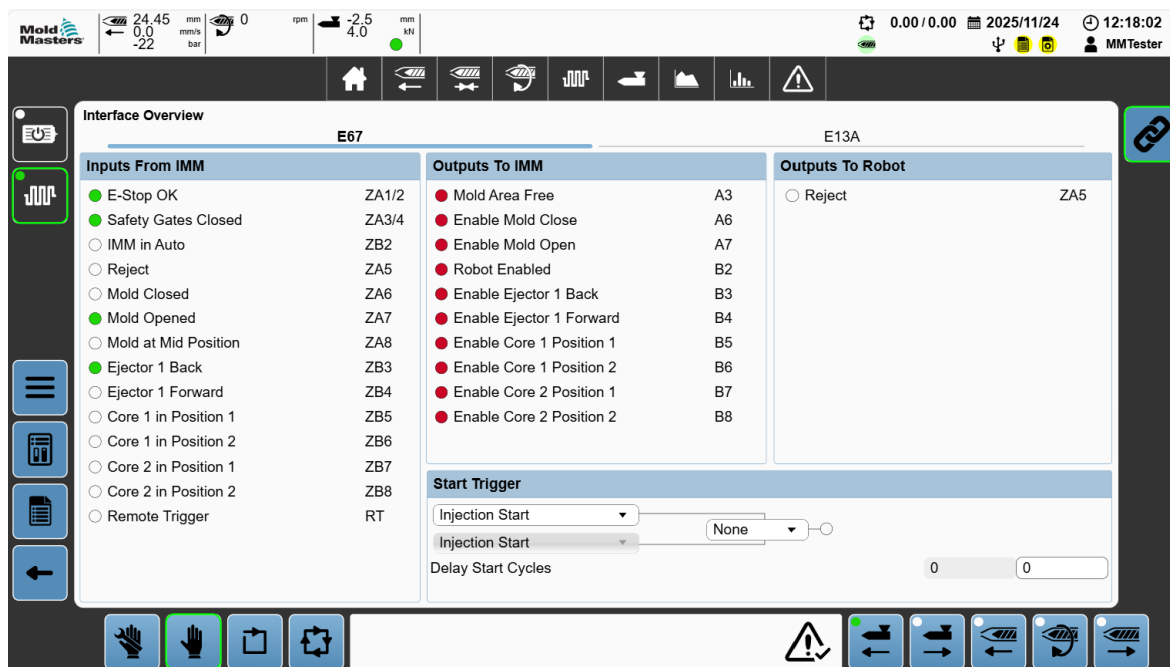
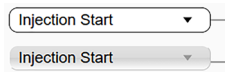

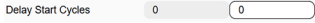

Figure 8-80 Interface Overview screen with E67 tab selected

Table 8-28 E67 Tab	
Field	Description
Inputs from IMM	A summary of digital input signals from the IMM through the Euromap 67 interface Values: Green or off
Outputs to IMM	A summary of digital output signals to the IMM through the Euromap 67 interface Values: Red or off
Outputs to Robot	A summary of signals passed to the robot (In the case that the E67 interface is daisy-chained to another device.)

Table 8-29 Start Trigger Panel	
Field/Button	Description
	<p>E-Multi auto cycle start triggers has the following dropdown options:</p> <ul style="list-style-type: none"> • Injection Start • Mold Closed • Ejector 1 Back • Ejector 1 Forward • Core 1 In Position 1 • Core 2 In Position 2 • IMM Screw Position • Remote Trigger • No Trigger <p>Two triggers are available, but the second trigger is optional.</p> <p>The E-Multi Mini injection sequence starts when the start condition changes from false to true.</p>
	<p>Logic selection for the injection start triggers</p> <p>AND - Both the start trigger conditions must be satisfied to start injection.</p> <p>OR - Injection starts when either of the start trigger conditions are satisfied.</p> <p>None - When the first start trigger condition is used (second condition cannot be set).</p>
	<p>Delay Start Cycles</p> <p>Actual delayed cycle count is shown in the grayed-out field.</p> <p>Delays the start of the first cycle of the E-Multi Mini until the start trigger is observed the number of times set here.</p> <p>Values: 0 and 255</p>

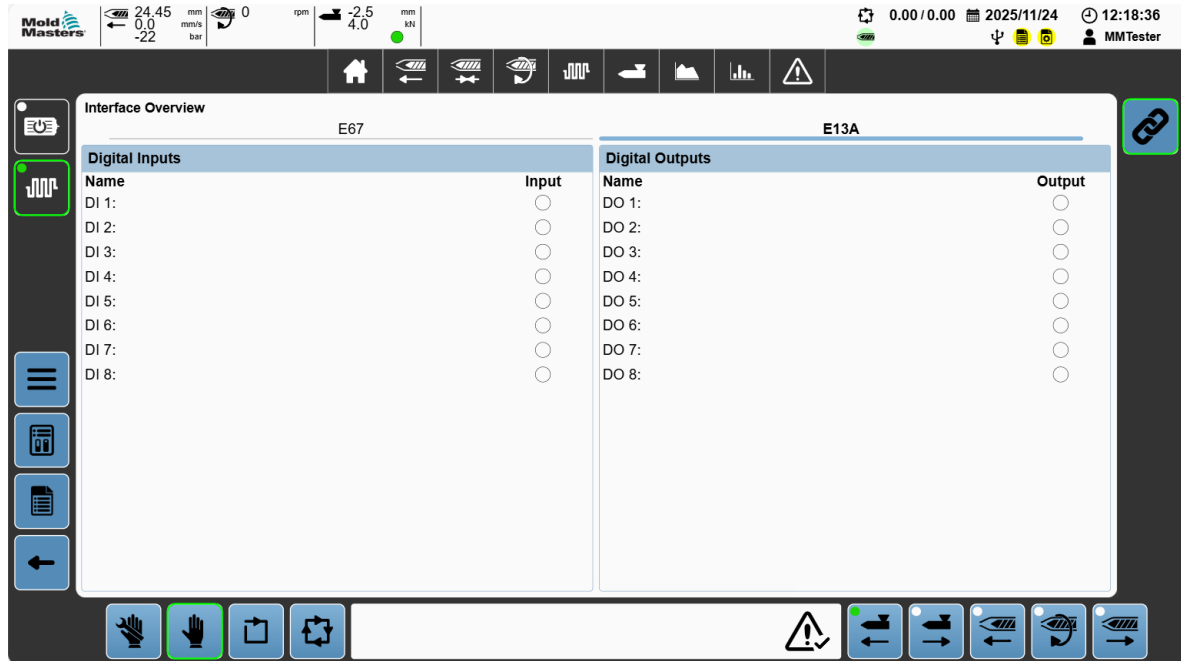

Figure 8-81 Interface Overview screen with E13A tab selected

Table 8-30 E13A Tab	
Field	Description
Digital Inputs	A listing of all available programmable input signals. See the Custom I/O screen for more details.
Digital Outputs	A listing of all available programmable output signals. See the Custom I/O screen for more details.

8.36 Key Switch

If additional, non-standard functionality is required, a key switch has been provided to make the functionality available. The key switch is a momentary switch with a spring return so the key switch can only be operated intentionally and cannot be left in the active position. The following is a list of available secondary functionality when the key switch is active.

All Servo Axes:

- If a motor is equipped with a brake, the brake can be forced off on the Axis screen when the key switch input is active, allowing the axis to be moved freely.
- Direct calibration—In calibration mode with the motors powered on, an axis can be calibrated directly to the minimum or maximum position when the key switch is active by holding the negative or positive jog button.

Injection:

- Use the standard injection velocity/pressure profile during purging.

Carriage:

- Allow carriage contact force build-up in setup or calibration mode without determining the mold sprue contact position first.
- Allow carriage contact force build-up while the barrel heats are not at temperature and soaked.
- Allow the current carriage position to be set as the mold contact position. The Start push button to begin determination changes to Set.

Custom I/O:

- Displays additional buttons on the Custom I/O Digital Outputs screen that when pressed forces the selected output on or off.

Section 9 - Software Operation



WARNING – READ MANUAL BEFORE OPERATION

Make sure that you have read *section Section 3 - Safety on page 3-1* before operating your E-Multi Mini controller.

Always make sure that the controller is in a safe-to-start position before operating the controller.

9.1 Logging in

When you turn on the E-Multi Mini controller, the Login dialog box is displayed.

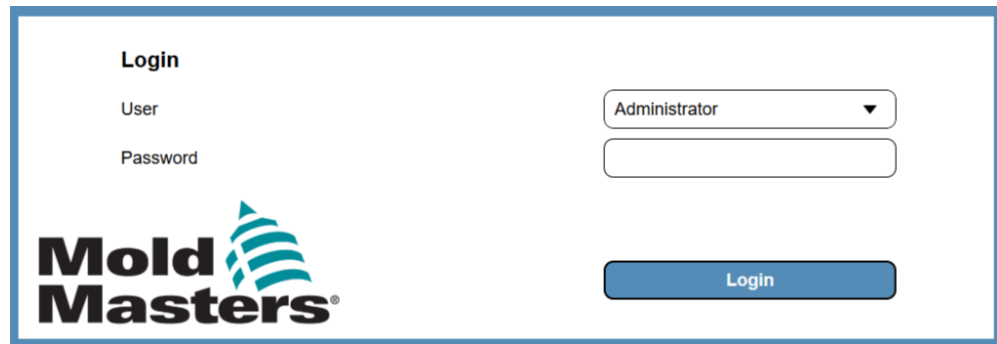

Figure 9-1 Login dialog box

1. Tap the User dropdown list box and tap one of the accounts.



NOTE

The default values of the User dropdown box are: Administrator, MMTester, Operator, Supervisor, and Technician. The Administrator and MMTester accounts are reserved for use by Mold-Masters personnel.

2. Tap the Password text box and enter the password for the account.



NOTE

The default password for the Operator, Supervisor, and Technician accounts is “1”. Anonymous logins are not permitted.

3. Tap the Login button.

9.2 Managing users

9.2.1 Navigating to the User Management screen

1. Tap the Directory button in the left panel.



2. Tap the Machine button.



3. Tap the User button.



All users are displayed in the User Management screen:

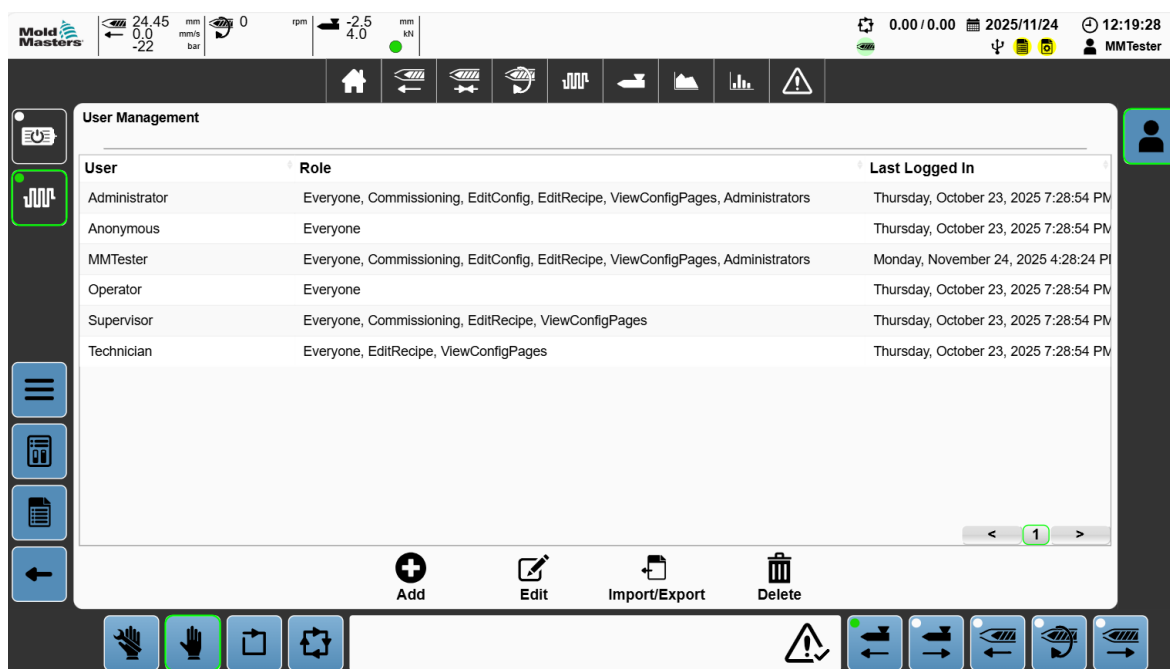

Figure 9-2 User management screen

All users, except for Operator, can access this screen, and can create, edit, or delete user profiles that have a level lower than the currently logged-in user.

9.2.2 Creating a user

1. Tap the Add button.



2. Tap the fields of the Add a user dialog box and enter information.

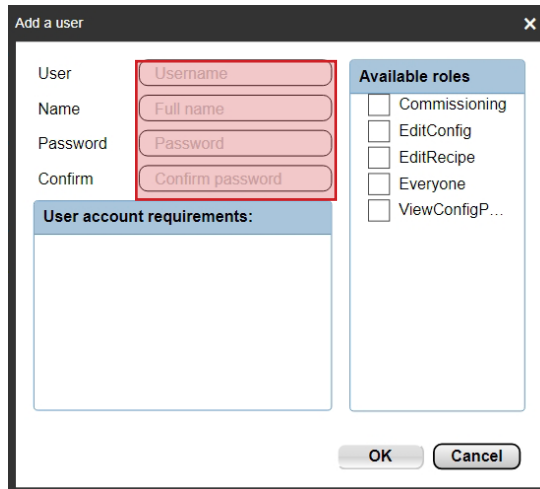

3. Tap the appropriate check boxes of the Available roles panel.

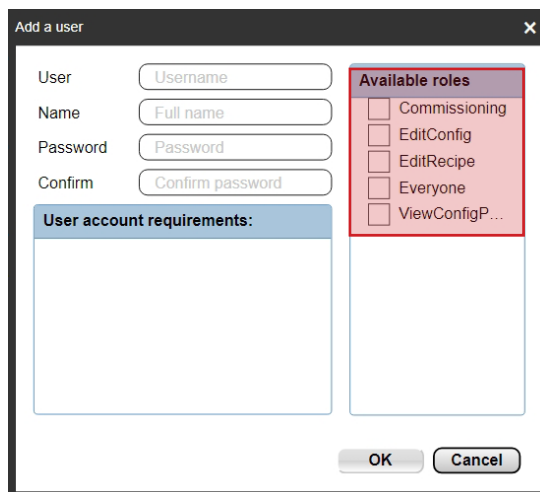

4. Tap the OK button.

The new user is added to the list of users.

9.2.3 Deleting a user

1. From the list of users, tap the user you want to delete.
2. Tap the Delete button.
3. Tap the Yes button in the Confirmation dialog box.

9.2.4 Exporting user management data

1. Tap the Import/Export button.
2. In the Export panel of the Import/Export dialog box, tap the Filename text box and enter a filename.

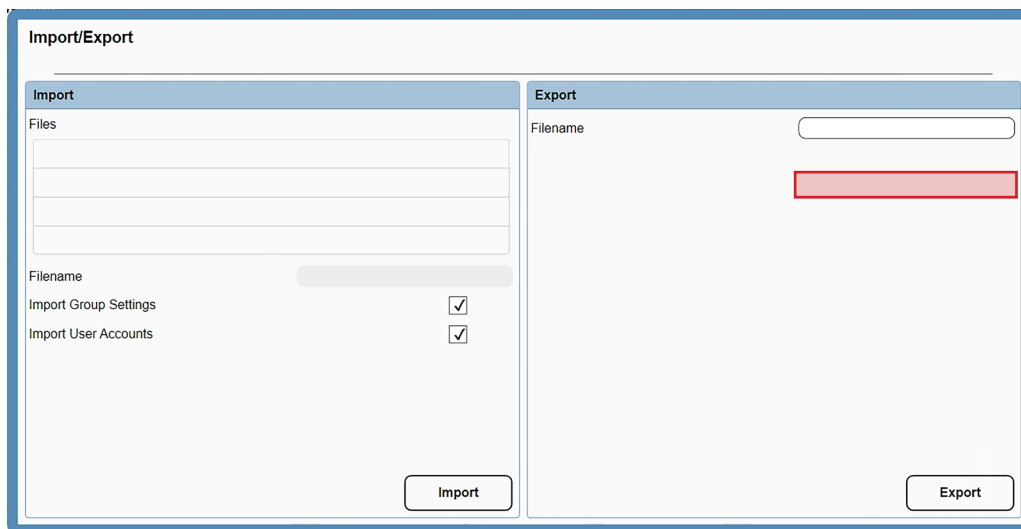

3. The user data is exported to the User Data/Users folder.

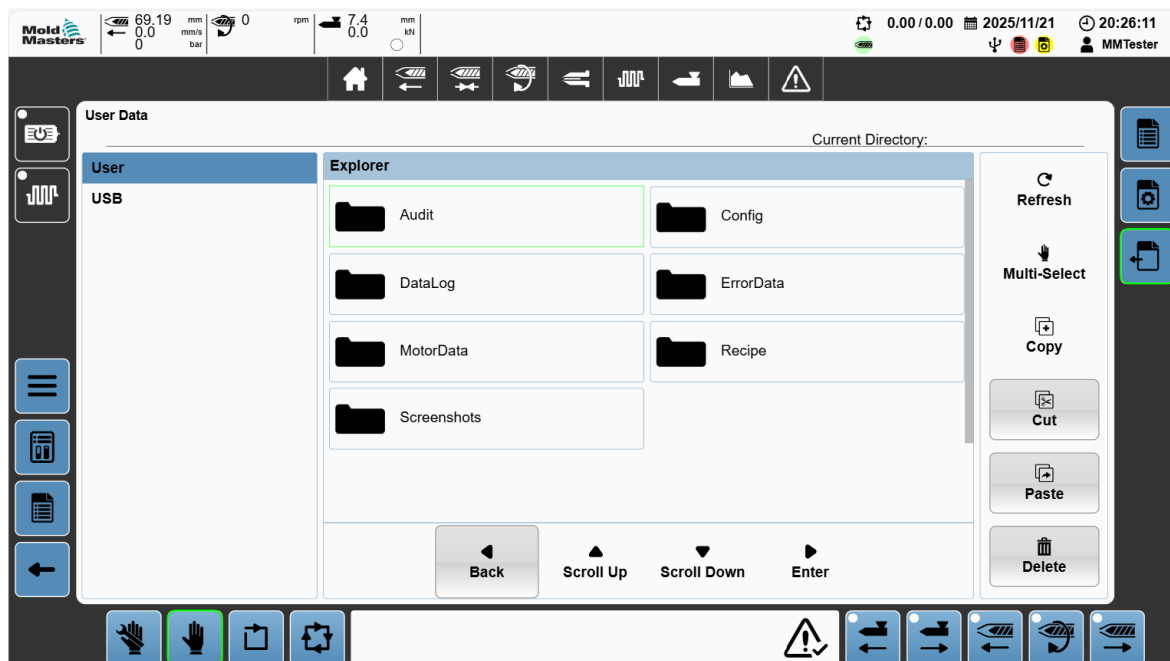
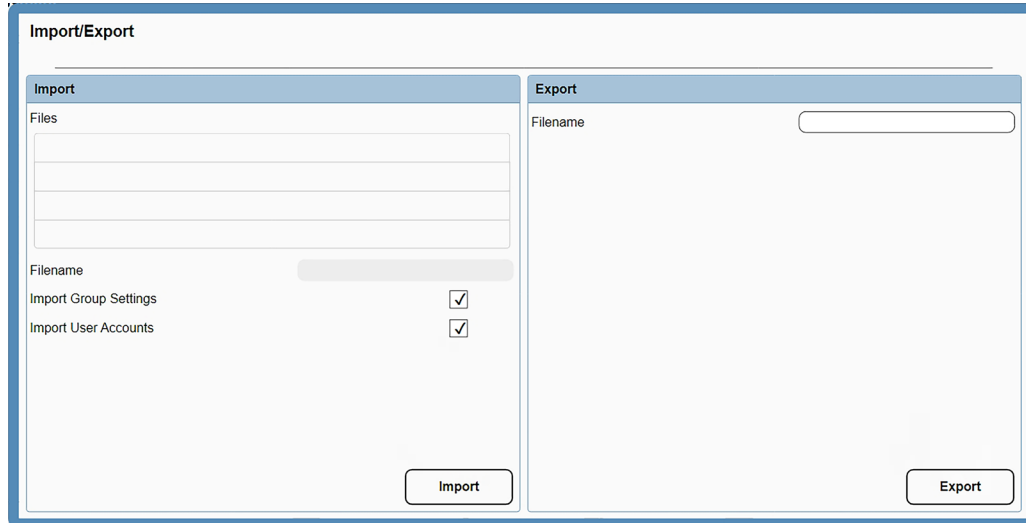

Figure 9-3 User data screen

9.2.5 Importing user management data

1. On the User Data screen, move the .usr file to the User Data/Users folder. See *section 8.22.3 User Data on page 8-104* for more information about the User Data screen.
2. Go to the User Management screen and tap the Import/Export button.
3. From the list of files, tap the file that you want to import.
4. Tap the Import button.



9.3 Managing recipe and fixed data

9.3.1 Creating a recipe file

1. Tap the data button in the left panel to go to the Data screen.



2. Tap in the text box and use the pop-up keyboard to enter a name.



3. Tap the create button.



The new recipe data file will be displayed in the file list and will be used as the active loaded recipe data file.

9.3.2 Saving recipe data

1. Tap the data button in the left panel to go to the Data screen.



2. Tap a recipe file in the file list.
3. Tap the save button.

The saved data file will be used as the active loaded recipe data file.

9.3.3 Deleting a recipe file

1. Tap the data button in the left panel to go to the Data screen.



2. Tap a recipe file in the file list.
3. Tap the delete button.

9.3.4 Creating a fixed data file

1. Tap the Fixed data screen button in the Contextual panel.



2. Tap in the text box and use the pop-up keyboard to enter a name.



3. Tap the create button.



The new fixed data file will be displayed in the file list and will be used as the active fixed data file.

9.3.5 Saving fixed data

1. Tap the Fixed data screen button in the Contextual panel.



2. Tap a fixed data file in the file list.
3. Tap the save button.

The saved data file will be used as the active fixed data file.

9.3.6 Deleting a fixed data file

1. Tap the Fixed data screen button in the Contextual panel.



2. Tap a fixed data file in the file list.
3. Tap the delete button.

See section 8.22.1 Recipe Data on page 8-100 for more information.

9.4 Configuring the controller

9.4.1 Graphical representation of the axis stroke limits

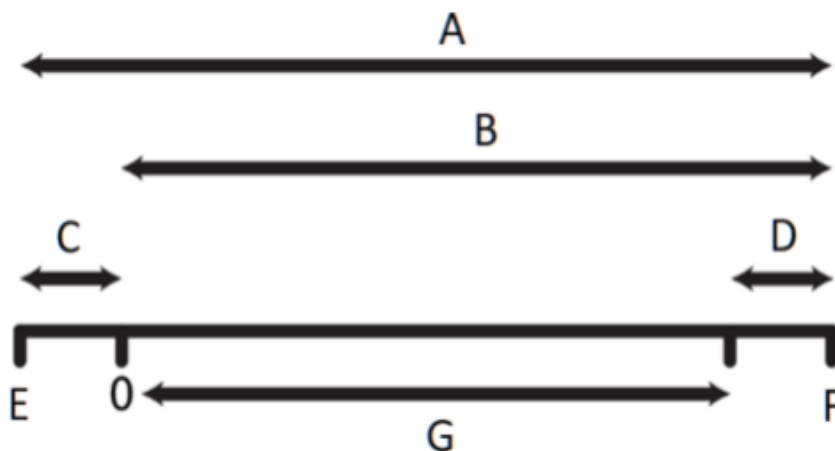

Figure 9-4 Axis stroke limits

The Valid stroke range represents the allowable stroke positions for the axis motion profile.

Table 9-1 Axis Stroke Limits		
	Field	Description
A	Total Mechanical Stroke	Physical maximum of the axis stroke, from negative to positive end stop Values: Any positive value
B	Calibration Stroke	Position taken over during calibration at positive end stop Calibration Stroke = Total Mechanical Stroke – Minimum Position Stroke Offset
C	Minimum Position Offset	Offset from the minimum stroke to determine the software minimum stroke
D	Maximum Position Offset	Offset from the maximum stroke to determine the software maximum stroke
E	Negative Hard Stop for the axis	Physical minimum position

Table 9-1 Axis Stroke Limits		
	Field	Description
F	Positive Hard Stop for the axis	Physical maximum position
G	Valid Stroke Range for the axis	Target stroke for motions under normal conditions is restricted to this range
0	Origin of the axis	Represents the 0 mm position for the axis

9.4.2 Using the Conditions detailed-dialog box

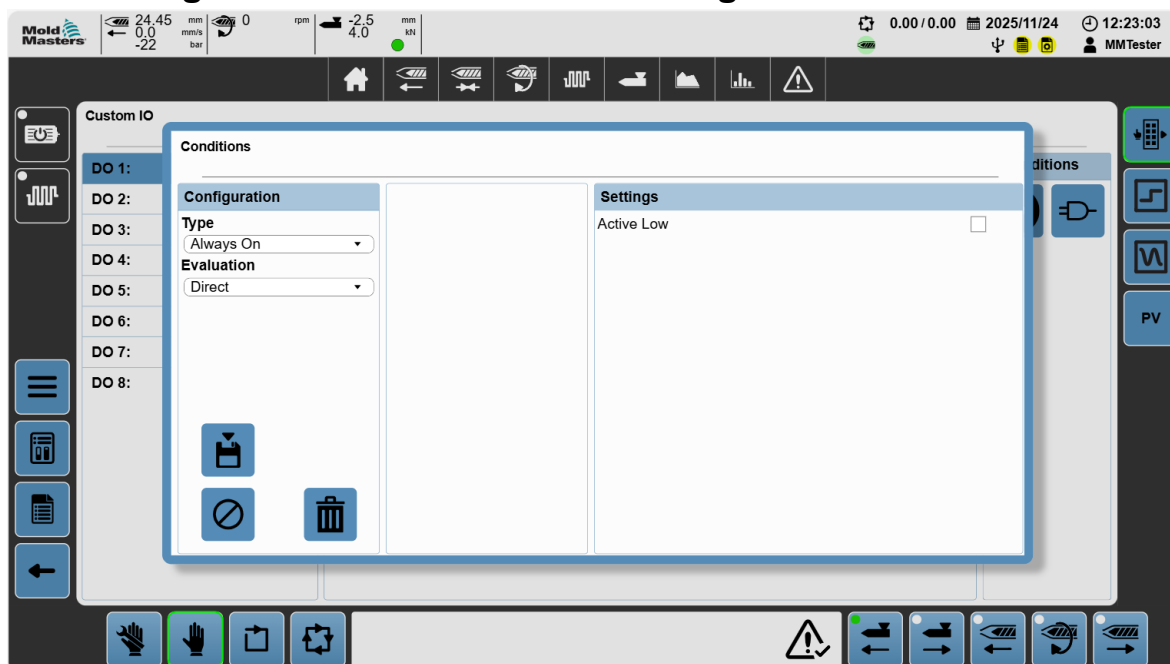





Figure 9-5 Conditions detailed-dialog box

Table 9-2 Conditions Detailed-Dialog Box	
Field/Button	Description
<p>Type</p> <p>Always On ▼</p>	<p>Type</p> <p>Condition type selection</p> <p>Values:</p> <ul style="list-style-type: none"> • Always Off • Euromap 67 • E-Multi • MAx Axis • Digital Input • Digital Output • Analog Input • Analog Output • Mode • System • Cycle • E-Drive • Timers • Counters <p>Tap this dropdown box to select a condition type.</p> <p>After you choose a condition type, the settings panel will display related options.</p>

Table 9-2 Conditions Detailed-Dialog Box	
Field/Button	Description
<p>Evaluation</p> 	<p>Evaluation</p> <p>Direct—Is true when the variable is true</p> <p>Rising Edge—Is true as soon as the variable changes from false to true</p> <p>Falling Edge—Is true as soon as the variable changes from true to false</p>
	<p>Delete button</p> <p>If this dialog was opened from an existing interlock, the delete button will remove the interlock from the motion step.</p> <p>If the dialog was opened from the New Interlock button, this will close the dialog and not affect the motion step.</p>
	<p>Save button</p> <p>Tap this button to save the new or changed interlock to the selected motion step.</p>
	<p>Cancel button</p> <p>Tap this button to close the dialog box without saving changes.</p>

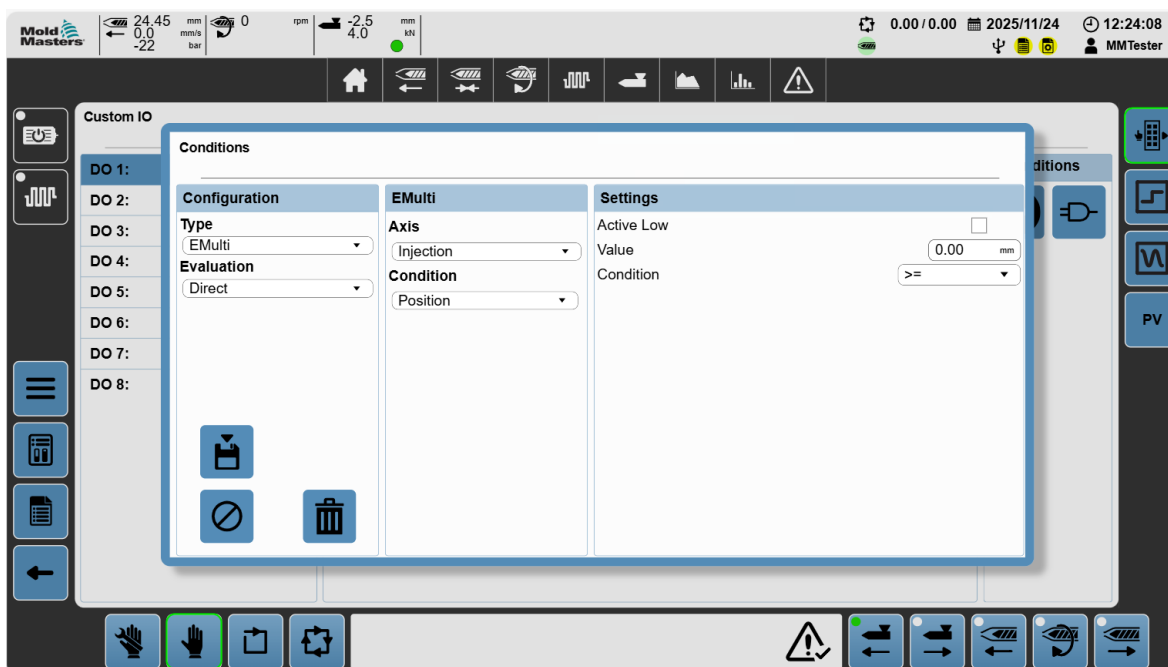

Figure 9-6 E-Multi panel



Table 9-3 E-Multi Panel	
Field	Description
<p>Axis</p> 	<p>Axis</p> <p>Tap this dropdown box to select the axis.</p> <p>Values:</p> <ul style="list-style-type: none"> • Injection • Carriage • Plasticizing • Valve Gate • Air Valve
<p>Condition</p> 	<p>Condition</p> <p>The condition type determines how the true condition is evaluated.</p> <p>Values:</p> <ul style="list-style-type: none"> • Negative End Stop • Positive End Stop • Position* • Active <p>*The Position condition is only applicable if the selected axis has a position feedback.</p> <p>Tap this dropdown box to select the condition type.</p>

Table 9-4 Settings Panel	
Field	Description
Active Low	Tap this check box to invert the condition evaluation.
Value	<p>Set the position used for the condition comparison.</p> <p>Values: Any number</p> <p>Displayed only for the Condition selection of Position, or Types of Analog Input or Analog Output</p> <p>Tap this field to set the position used for the condition comparison.</p>
Condition	<p>Type of position comparison</p> <p>Values:</p> <ul style="list-style-type: none"> • >= (greater than or equal to) • > (greater than) • = (equals) • < (lesser than) • <= (lesser than or equal to) <p>Displayed only for the Condition selection of Position, or Types of Analog Input or Analog Output</p> <p>Tap this dropdown box to select a type of position comparison.</p>

9.4.3 Using the Motor-Selection dialog box

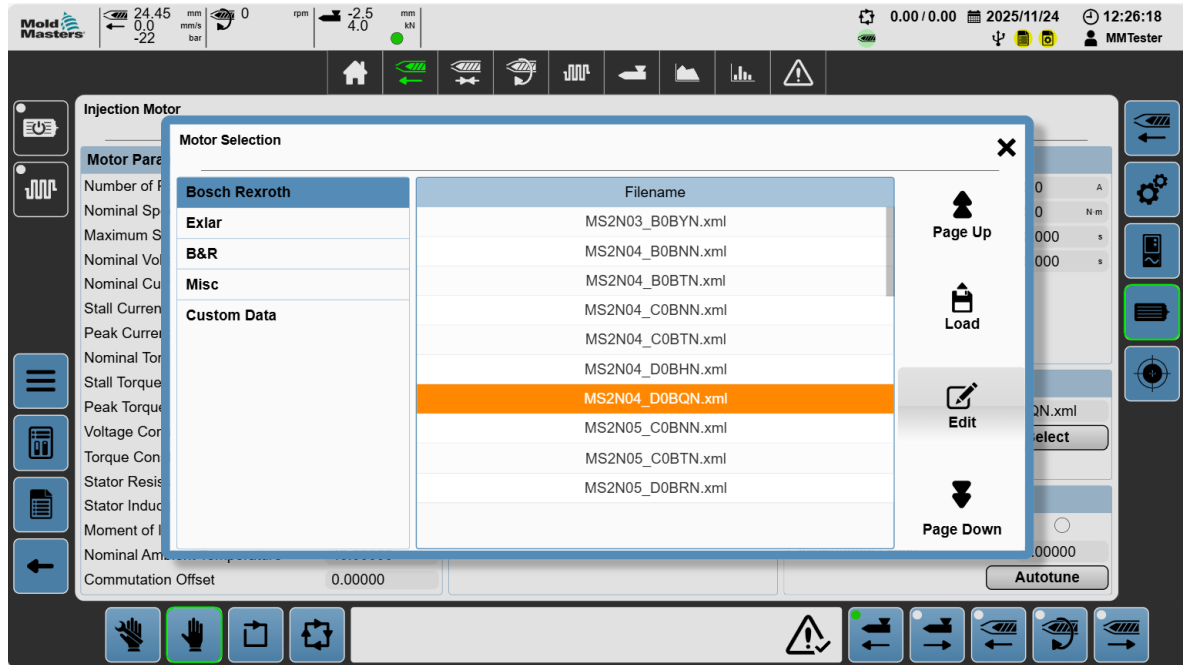





Figure 9-7 Motor-Selection dialog box

Table 9-5 Motor-Selection Dialog Box	
Field/Button	Description
	<p>List of available motor groups</p> <p>Tap to select a specific motor group</p> <p>Values:</p> <ul style="list-style-type: none"> • Bosch Rexroth • Exlar • B&R • Misc. • Custom Data
	<p>List of available motors in a motor group</p> <p>Tap to select a specific motor.</p>
	<p>Motor Has a Brake</p> <p>Tap Load and tap this check box to indicate that the motor has a brake.</p>
	<p>Screen Up button</p> <p>Tap this button to navigate up through the motor list</p>

Table 9-5 Motor-Selection Dialog Box	
Field/Button	Description
 <p>Load</p>	<p>Load button</p> <p>Loads the selected motor data file to the axis. Changes made to the motor selection take over on boot up and a power cycle is required for them to take effect.</p>
 <p>Edit</p>	<p>Edit button</p> <p>Only available when the Custom Data motor group is selected. Opens the Edit Motor Data dialog box for the selected motor data file.</p>
 <p>Page Down</p>	<p>Screen Down button</p> <p>Tap this button to navigate down through the motor list.</p>

9.4.4 Configuring the I/O

All changes made on the Custom I/O screen are saved in Fixed data.

9.4.4.1 Navigating to the Custom I/O screen

1. Tap the Directory screen button in the left panel.



2. Tap the Machine button.



3. In the list of MMax screens, tap the Custom I/O screen button.



9.4.4.2 Assigning a custom name to a digital input

1. Go to the Custom I/O screen. See *section 9.4.4.1 Navigating to the Custom I/O screen on page 9-14* for more information.
2. On the list on the left, tap a digital input.

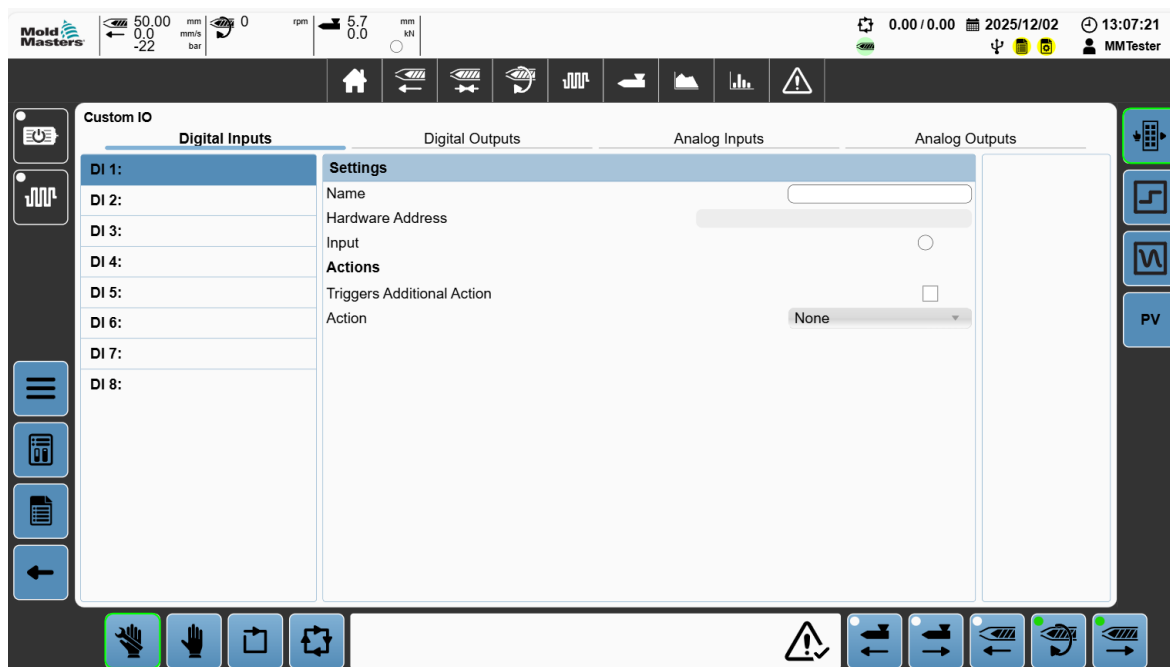

Figure 9-8 Custom I/O screen with digital inputs tab selected

3. Tap the Name field, and enter a name.

9.4.4.3 Navigating to a digital output

1. Tap the Digital Outputs tab.

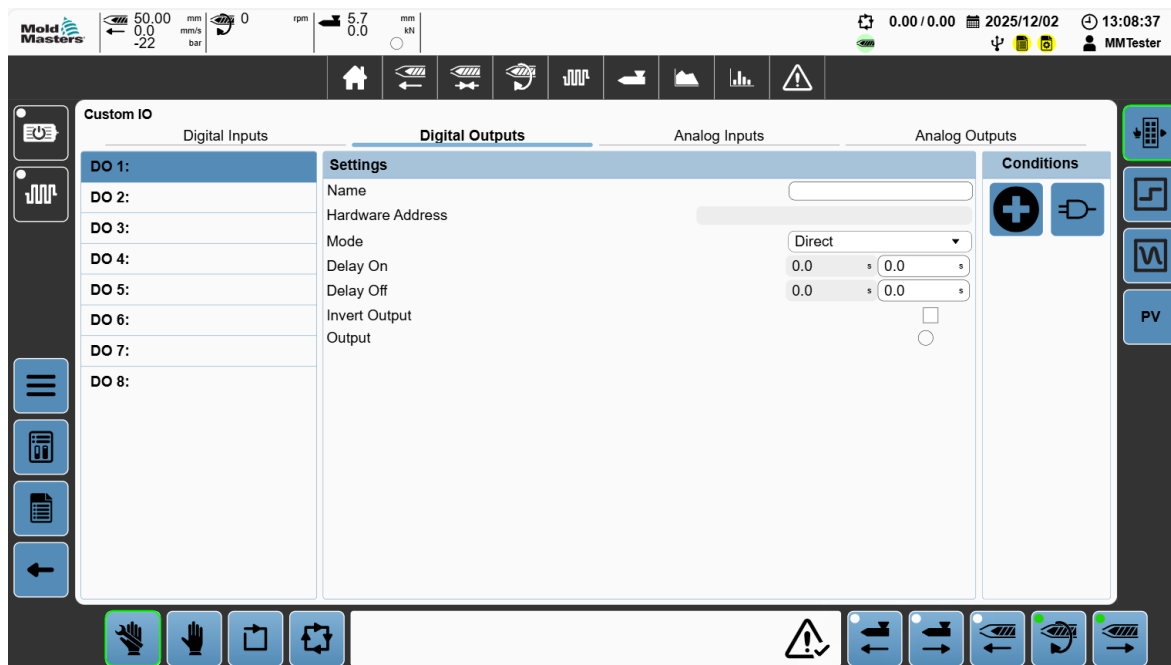

Figure 9-9 Custom I/O screen with digital outputs tab selected

9.4.4.4 Adding an output condition

1. Select a digital output. See section 9.4.4.3 Navigating to a digital output on page 9-15 for more information.
2. Tap the New Conditions button.



3. Tap a condition type from the Type dropdown list box.

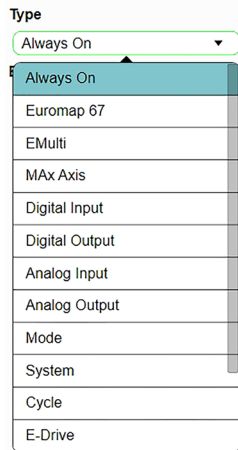

If you tap Mode, mode options will be displayed.

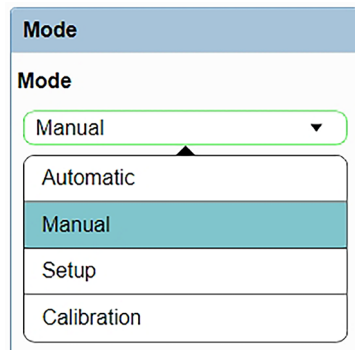

4. Tap the Save button.

The Conditions panel shows the conditions for the selected digital output.

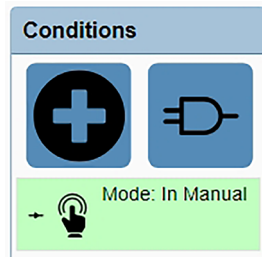

9.4.4.5 Editing an output condition

1. Tap a condition in the Conditions panel.

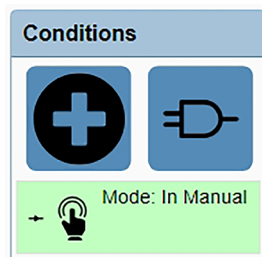

2. Edit the condition.

3. Tap the Save button.

9.4.4.6 Deleting an output condition

1. Tap a condition in the Conditions panel.

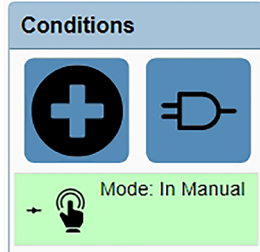

2. Tap the delete button.



The Conditions Panel will show the change.

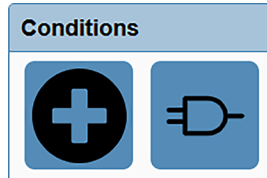

9.4.4.7 Editing the output settings

1. Select a digital output. See *section 9.4.4.3 Navigating to a digital output on page 9-15* for more information.
2. In the center panel, edit the output settings.
3. Tap the Save button.

See *section 9.4.4.1 Navigating to the Custom I/O screen on page 9-14* for more information.

9.5 Using the controller

9.5.1 Powering the motors

1. Tap the Motor button in the left panel.



When the motors are powered, the LED and the border of the Motor button will turn green.



9.5.2 Turning off power to the motors

1. Tap the green Motor button in the left panel.



2. Tap OK in the dialog box.

When power is turned off to the motors, the LED and the border of the Motor button will turn white.



Note: Some critical alarms will turn off the motors or restrict the motors from powering if they are active. If you cannot power the motors, check the active alarms.

9.5.3 Putting the controller into calibration mode

Calibration mode allows you to move the axes without restrictions. Any configured interlocks or software position limits will be ignored while jogging in calibration mode. Calibration mode should only be used to calibrate the axis, or when something has moved the axes outside of the software's limited range and the axis is not able to move in another mode.

You must have commissioning permissions to access calibration mode.

3. Tap the Calibration button in the Contextual (right) panel to put the controller into calibration mode.



See *section 9.4.4.1 Navigating to the Custom I/O screen on page 9-14* for more information.

See *section 8.1.5 Footer on page 8-8* for more information on the Footer buttons.

9.5.4 Putting the controller into setup mode

Setup mode allows you to move the axes freely within the software position limits. Any configured interlocks will be ignored while jogging in setup mode.

1. Tap the Setup button in the Footer to put the controller into setup mode.



See *section 8.1.5 Footer on page 8-8* for more information on the Footer buttons.

9.5.5 Putting the controller into manual mode

Manual mode allows you to move the axes within the predefined motion steps. All manual moves take into account the interlocks defined for the motion steps to be executed. Motion will be executed with the velocity and torque set up for each motion step.

1. Tap the Manual button in the Footer to put the controller into manual mode.



See *section 8.1.5 Footer on page 8-8* for more information on the Footer buttons.

9.5.6 Putting the controller into auto-mode

Requirements for auto-mode:

- Motor power on
- E67—Safety gates must be closed
- E67/Machine—E-Stops must be OK
- Enabled M-Ax axes must be in their start positions
- No critical alarms active

1. Tap the Auto button in the Footer to put the controller into auto-mode.



If the change to automatic mode is not possible, an alarm will be displayed in the footer.



2. If an alarm is displayed, tap the alarm icon on the right side of the Footer alarm display.



Once the machine is switched into auto-mode, the M-Ax axes will monitor for the axis start trigger to be OK. Once the axis start trigger is OK, the motion steps will check the steps interlocks and execute the motion steps until all the steps are completed. After all the steps are completed, the axis will again wait for the axis start trigger to begin motion again.

Section 10 - Maintenance



WARNING – READ MANUAL BEFORE OPERATION

Read “Section 3 - Safety” before doing maintenance procedures on the controller.

10.1 Cleaning the touchscreen

The touchscreen should be cleaned, whenever required, with a moist, soft, clean cloth and dishwashing detergent, screen cleaner or alcohol (ethanol). The glass cleaner should be sprayed onto the cloth and not directly onto the touchscreen. To prevent unintentional operation during cleaning, the power should be switched off.



CAUTION

Abrasive cleaners, aggressive solvents and chemicals, compressed air or steam cleaners must not be used to clean the touchscreen.

The surface coating of the touch screen is resistant to the following solvents per ASTM D 1308-02 and ASTM F 1598-95 for an exposure time of 24 hours without visible changes:

- Acetone
- Naphtha
- Ethanol
- Ammonia 5%
- Nitric acid 70%
- Gasoline (unleaded)
- Beer
- Brake fluid
- Sulphuric acid 40%
- Graphite
- Hydraulic fluid (Skydrol)
- Cooking oil
- Coffee
- Coca-Cola
- Tea
- Lysol
- Diesel oil Dimethylbenzene
- Methyl ethyl ketone
- Vinegar
- Alkaline cleaning agents
- Caustic soda 5%
- Grease
- Ammonia-based glass cleaners
- Hydrochloric acid 5%
- Lubricants
- Sidolin glass cleaner
- Chlorine-alkaline cleaning and disinfecting agents (pH value min. 11) 1.5%
- Suntan oil and UV radiation
- Isopropanol
- Hydrogen chloride 6%
- Stamping ink
- Ink
- Diesel
- Turpentine
- Methylbenzene

10.2 Preventive Maintenance

Table 10-1 Preventive Maintenance Schedule	
Preventive Maintenance	Frequency
Controller fan filters	Check monthly, replace if necessary

10.3 Putting the carriage in the service position

1. Tap the servo carriage button on the header menu bar of the home screen.

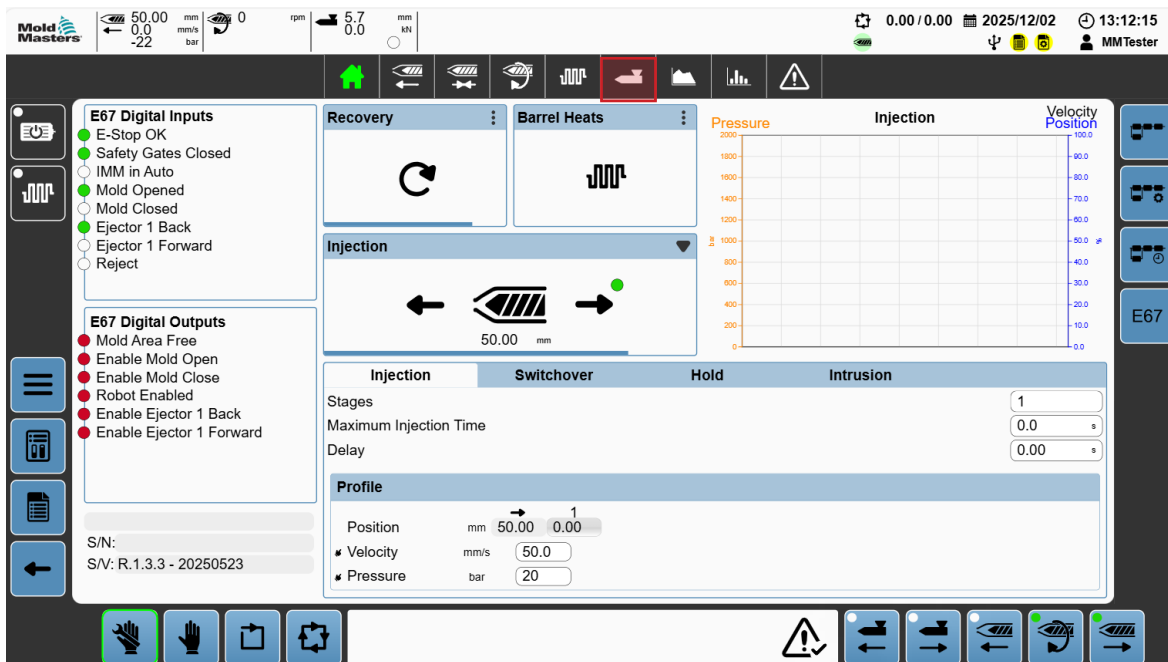

Figure 10-1 Home screen with the servo carriage button highlighted

2. Tap the Service button.

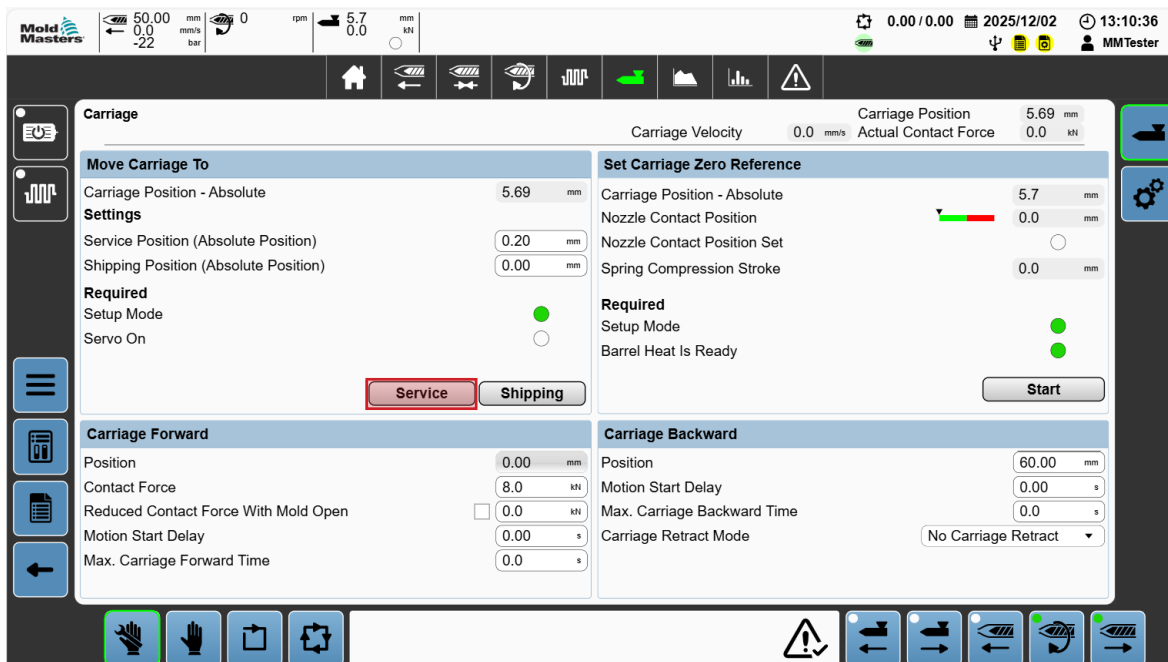

Figure 10-2 Servo carriage screen

10.4 Calibrating the carriage home position



WARNING

This procedure requires visual inspection of the machine while it is moving. Wear eye protection.

IMPORTANT

For proper calibration, make sure that the nozzle protrusion is set correctly.

The first time the E-Multi Mini is installed, any time it is transferred to a new machine with a different mold, or when the mold is changed in the machine, the carriage home position and contact force must be set.

Refer to the E-Multi Mini user manual for more details.

10.5 Referencing the injection axis



CAUTION

The injection referencing routine verifies the injection stroke by moving the screw fully back and then fully forward. Referencing will fail if the screw cannot achieve the full stroke.

1. The controller must be in setup mode with heats on and at operating temperature, carriage referenced, and carriage retracted from the mold.
2. Go to the Injection settings screen.
3. Use the contextual menu to go to the Injection calibration screen.
4. Tap the Start button.



Once the calibration is started, the injection axis will move automatically.

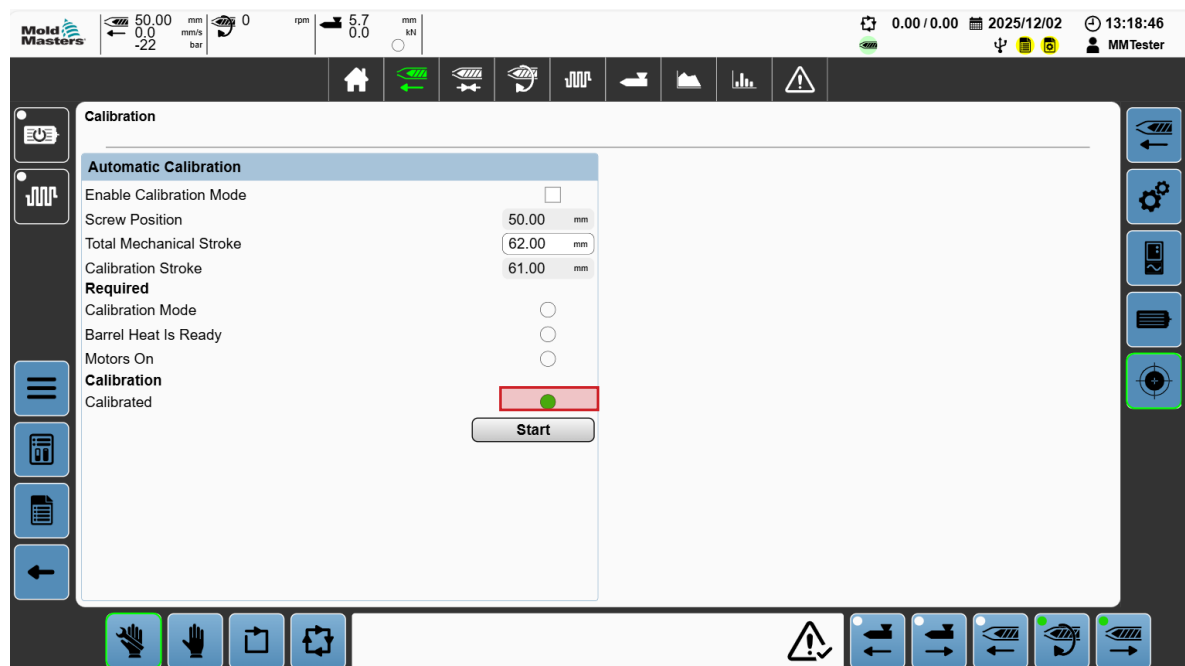

Figure 10-3 Referencing the injection axis

5. Wait for the screw to move fully back and then fully forward. Referencing is complete when the screw position is just below 0.

10.6 Servicing and repairing the controller



WARNING

Always isolate your controller at the power supply before you open the unit to inspect it or replace fuses.

10.6.1 Replacing parts

You should not have to repair any controller parts at the board level other than the fuses. In the unlikely event of a board failure, Mold-Masters will repair or exchange the board.

10.6.2 Inspecting and cleaning



CAUTION

External cables should be checked to see that there has been no damage to the flexible conduit, plugs, or sockets. If the flexible conduit has been damaged or if there are any exposed conductors, the loom must be replaced.

1. Inspect the fan filters monthly.
 - a) If the filters are clogged, replace them. Replacement filters can be obtained from Mold-Masters. Please quote the model type and year of manufacture when ordering.
 - b) Use a light brush and a vacuum cleaner to remove dust from the cabinet.
2. If the equipment has been subject to vibration, use an insulated screwdriver to check that no terminals have become loose.

10.7 Updating the software

It is not necessary to send your control system back to Mold-Masters for upgrades. Instead, on request, Mold-Masters will send you an upgrade in the form of a USB drive that can be read by your controller. The following instructions will guide you through the upgrade procedure.

Mold-Masters recommends that you always wait until your controller is free before implementing any upgrade. This ensures that, in the event of a mishap such as an error or a power interruption at a crucial point, normal production will not be adversely affected.

10.7.1 Saving mold data



CAUTION

Recipes and machine (fixed) data are stored in the controller memory. Mold-Masters recommends saving the machine data and mold data prior to upgrading the software.

1. Go to the Recipe screen.
2. If you need to create a new recipe:
 - a. Enter a name for the new recipe in the text box next to the Create button.

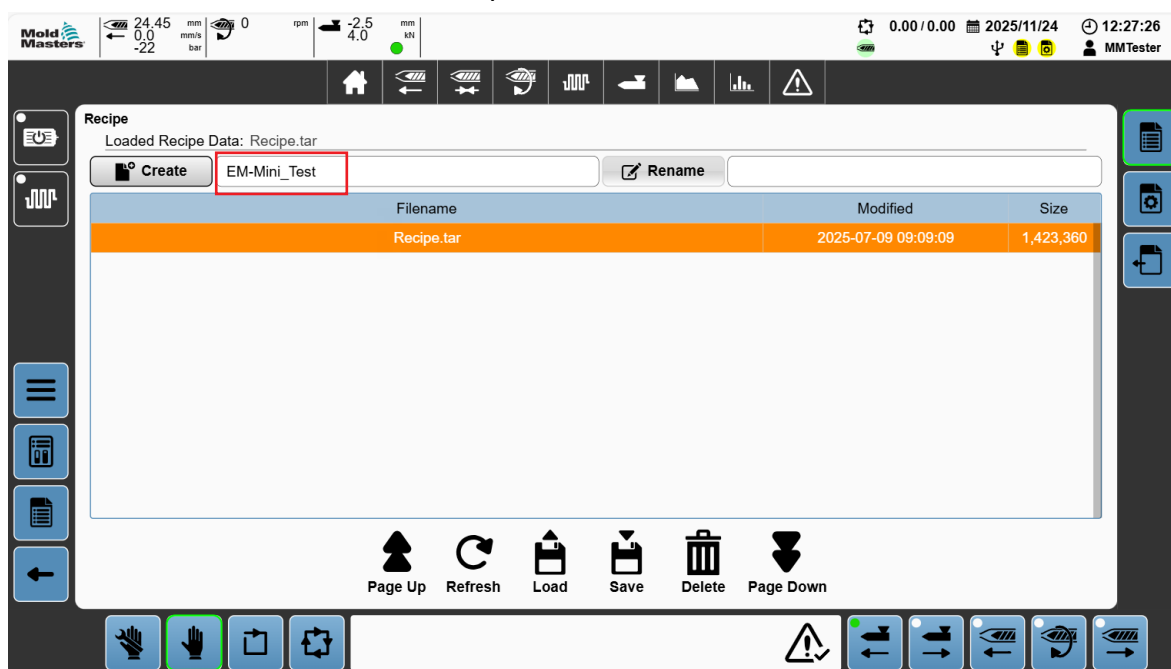

Figure 10-4 Recipe data screen with name tab selected

- b) Tap the Create button.

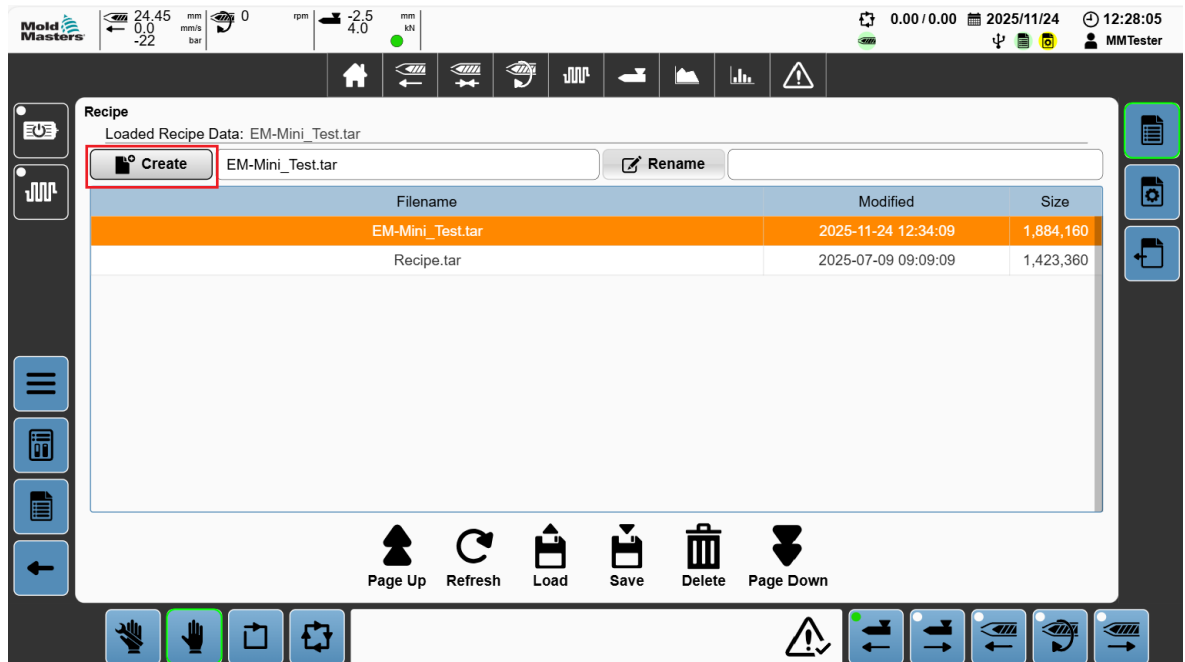

Figure 10-5 Recipe data screen with create button selected

- c. Tap the Yes button in the Confirmation dialog box.
3. If you need to overwrite a recipe:
 - a. Tap the fixed data recipe that you want to save data to, and tap the Save button.
 - b. In the confirmation dialog box, tap the Yes button to overwrite the file.

10.7.2 Saving fixed (machine) data

1. Go to the Fixed data screen.
2. If you need to create a new recipe:
 - a. Enter a name for the new recipe in the text box next to the Create button.

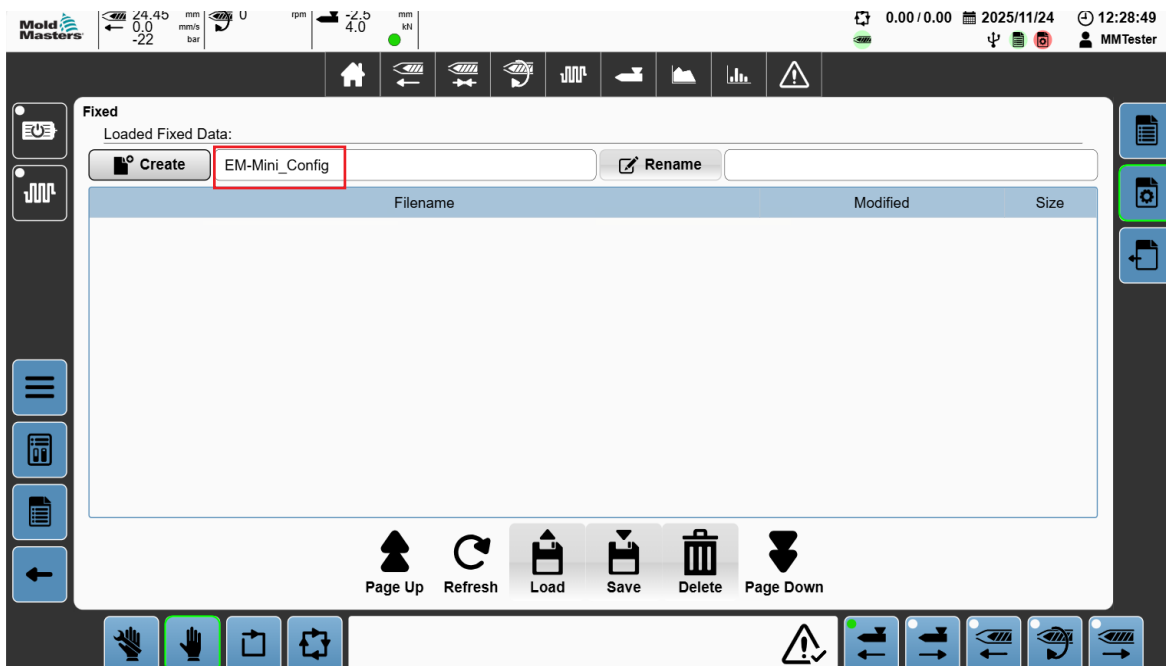

Figure 10-6 Fixed data screen with name tab selected

b. Tap the Create button.

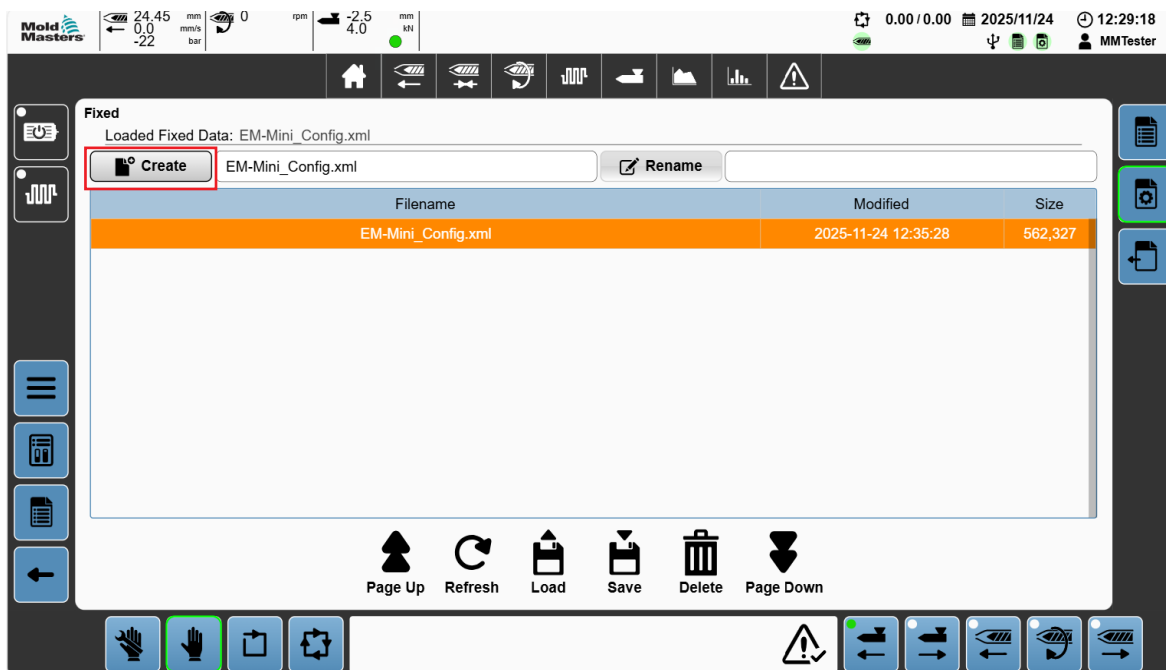

Figure 10-7 Fixed data screen with create button selected

c) Tap the Yes button in the Confirmation dialog box.

3. If you need to overwrite a recipe:
 - a. Tap the fixed data recipe that you want to save data to, and tap the Save button.
 - b. In the confirmation dialog box, tap the Yes button to overwrite the file.

10.7.3 Backing up user data



CAUTION
 Mold-Masters recommends that you create a backup copy of the machine data and mold data before upgrading the software.

1. Insert the USB thumb drive with the machine and mold-data backup files in a USB port.

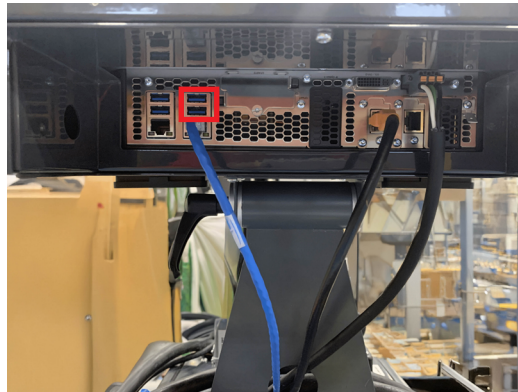

Figure 10-8 USB connections on the bottom of the touchscreen

2. Go to the User Data screen.
3. Tap the Recipe folder, and tap the Enter button.

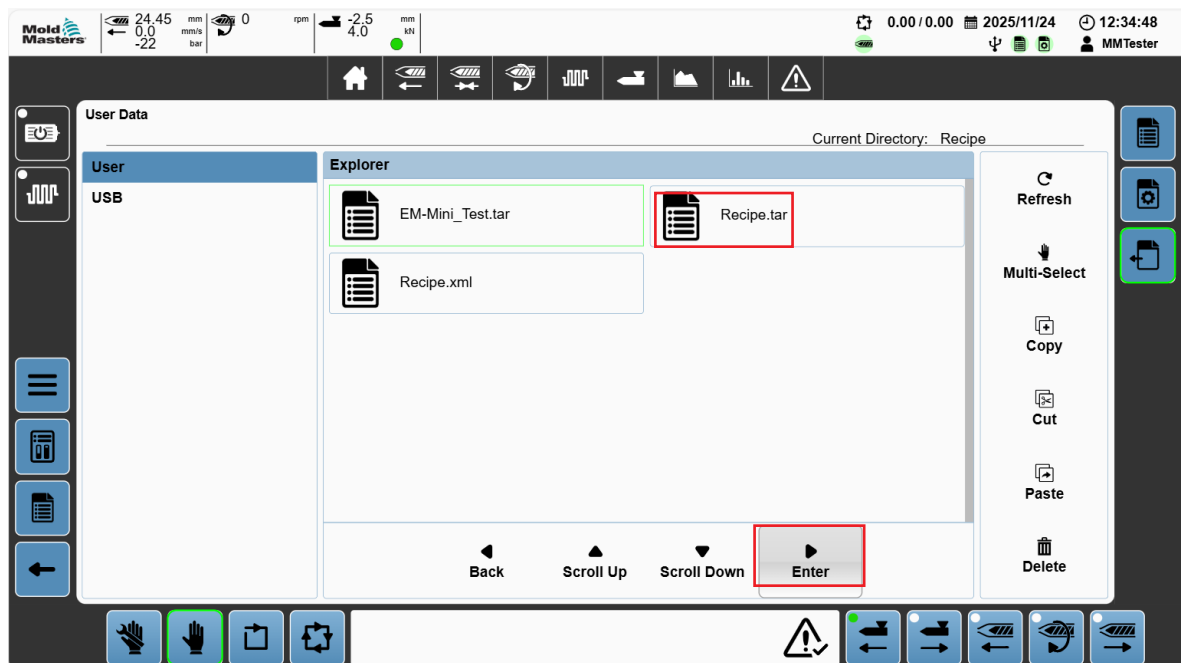

Figure 10-9 User data screen with recipe folder and enter button selected

4. Select the file(s):
 - a. If you need to back up one file, tap the file.
 - b. If you need to back up multiple files, tap the Multi-Select button in the right column and tap the files.

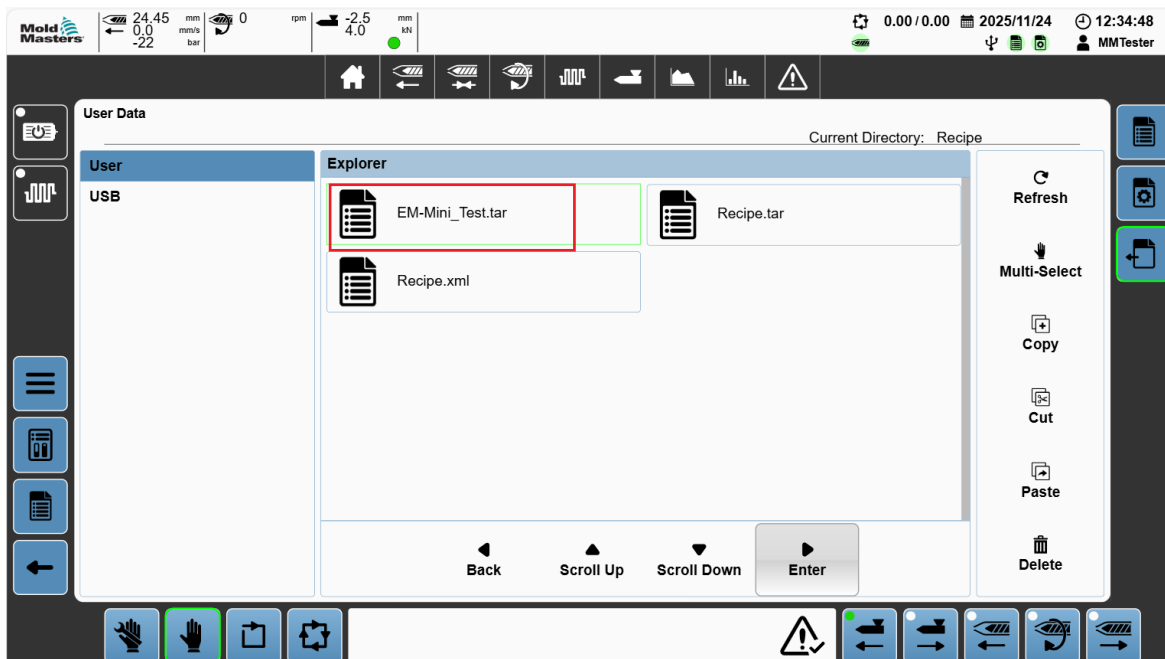

Figure 10-10 User data screen with files selected

5. Tap the Copy button.

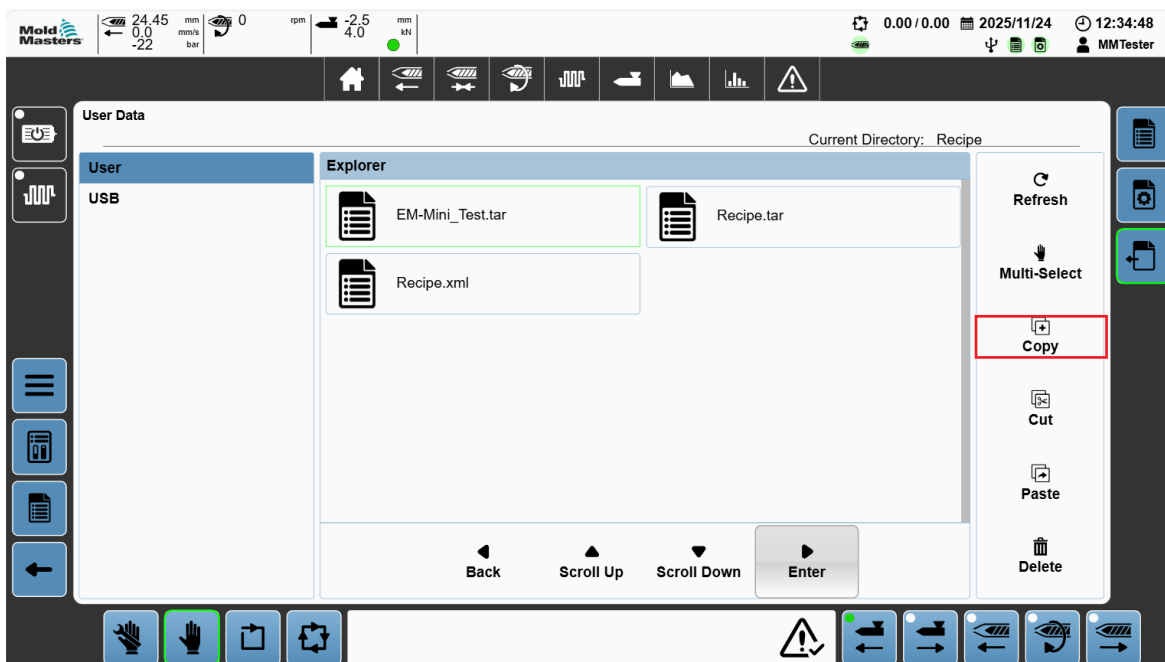

Figure 10-11 User data screen with copy button selected

6. Tap **USB** in the left column and go to the folder that you want to save.
7. Tap the Paste button.

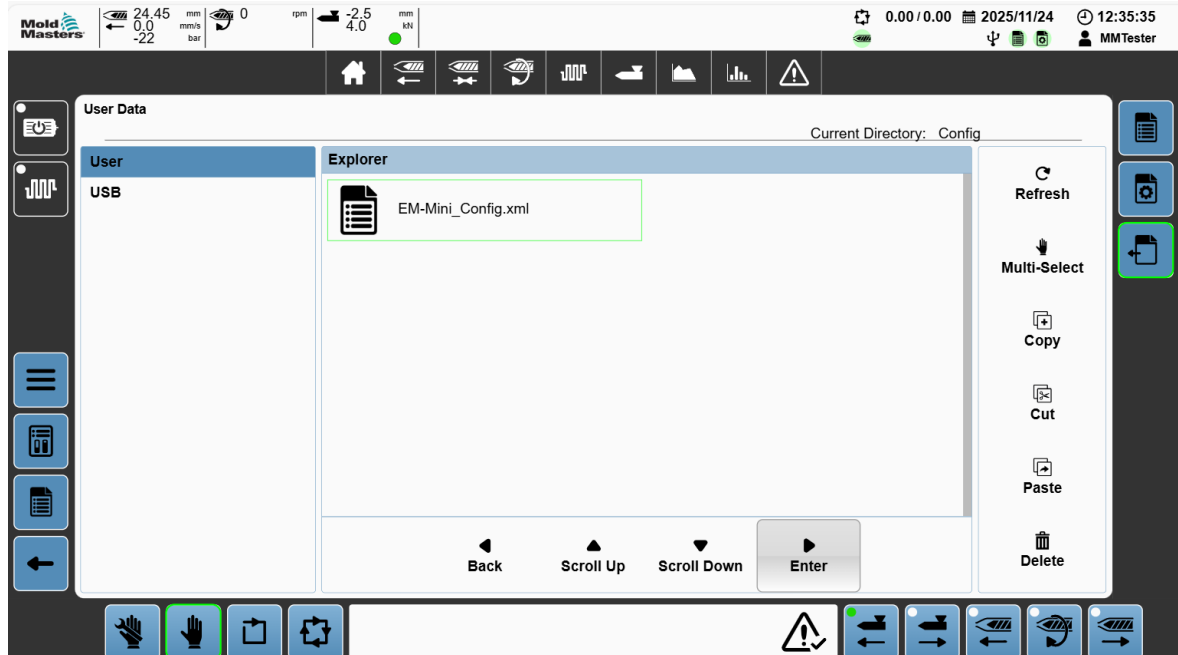

Figure 10-12 User data screen with config folder selected

8. To back up the fixed data files, tap **User** in the left column
9. Tap the Config folder, and tap the Copy button.
10. Tap **USB** in the left column.
11. Tap the Paste button.

10.7.4 Installing new software

1. Power down the controller following the instructions in *section 6.3 Powering off on page 6-2*.
2. Insert the USB thumb drive with the software update provided by Mold-Masters in a USB port.

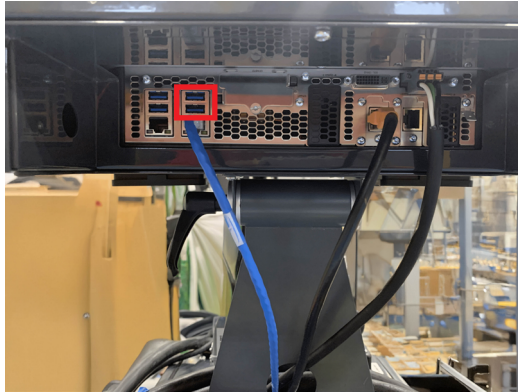

Figure 10-13 USB connections on the bottom of the touchscreen

3. Power on the controller following the instructions in *section 6.3 Powering off on page 6-2*.
The software has completed installing once the controller boots up to the login screen.
4. Remove the USB drive from the controller.
5. Log in to the controller.
6. Go to the Fixed data screen.
7. Load the fixed recipe data.
8. If a dialog is displayed instructing you to restart the controller:
 - a) Tap the Restart button, and wait for the controller to restart.
 - b) Log in to the controller.
 - c) Go to the Recipe data screen.
 - d) Load the fixed recipe data.

Section 11 - Troubleshooting



WARNING – READ MANUAL BEFORE OPERATION

Read “Section 3 - Safety” before doing maintenance procedures on the controller.

11.1 Doing an electrical check of a thermocouple

The controller system can monitor thermocouple performance. A working thermocouple will show a realistic temperature based on the environment it is in. Defective thermocouples will read -100°C on the controller.

1. If a thermocouple appears to be defective, test the thermocouple at the support beam or hot runner connector. Thermocouples should show output similar to those in the same area. If the output is significantly different, replace the thermocouple.
2. If the new thermocouple shows -100°C , there is probably a wiring problem. Check the wiring and connections.

11.2 Checking the heater continuity

This procedure requires access to the heater connector. The heaters are wired to the connector in pairs according to the wiring schematic.

1. Power down the machine before disconnecting the heater cable.
2. Set the multimeter to resistance.
3. Use the multimeter to check the resistance across the pins. They should show around $48\ \Omega$ for a 1000 W heater and $96\ \Omega$ for a 500 W heater. A reading of $0\ \Omega$ indicates a shorted heater and a reading of infinity indicates an open heater.

11.3 Checking the heater continuity

Transducer function is checked automatically every cycle. If the transducer is defective, an alarm will be shown on the touchscreen.

11.4 Checking the vibrator valve

1. The vibrator runs on every cycle when the feed screw is turning. If the vibrator is not moving, check the air pressure to the vibrator by closing the air needle valve and disconnecting the air line from the supply side of the valve.
2. Open the needle valve slowly and check for air pressure on the supply line. If there is no pressure, check the pneumatic connection to the machine. If there is pressure, close the valve, reconnect the air line to the valve and open the valve. Next, check the mechanical function by disconnecting the air supply tube from the solenoid valve on the support beam and applying compressed air to the tube. If the vibrator is working properly, it should start to vibrate when compressed air is applied.
3. If the vibrator is working, reconnect the air line to the valve and disconnect the valve cable. Apply 24 VDC to pin 1 and 0 VDC to pin 2. The valve should open and the vibrator should start to vibrate. If the valve does not move, replace the valve with a known good one.

11.5 Checking the motor temperature

The motor warning and alarm temperatures are factory settings that can only be changed by a Mold-Masters technician. The default values are:

- Warning temperature: 75°C
- Alarm temperature: 80°C

The E-Multi Mini controller automatically disables the motors when the alarm temperature is reached.

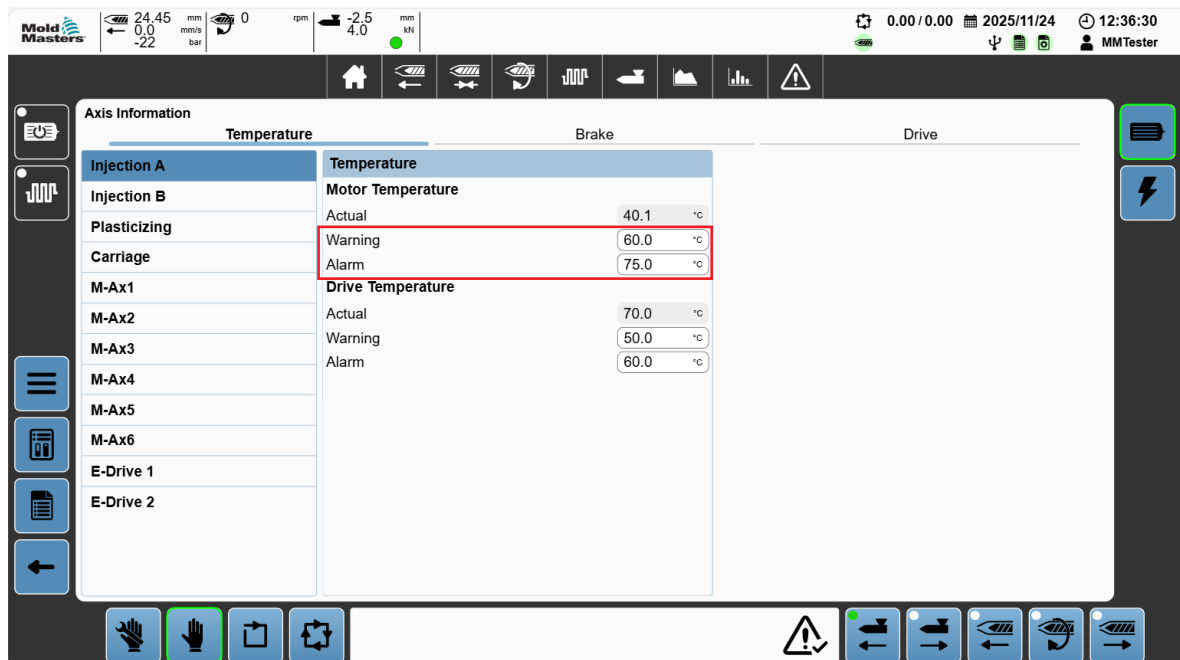

Figure 11-1 Axis information screen with Temperature tab selected

11.6 Troubleshooting the control system

The control system has several features, which provide an early diagnosis of faults in the control system.

If the system detects any malfunctions, it displays an error message on the Alarm screen.

If the system detects any abnormal condition, it displays a warning message on the Alarm screen.

Index

- A**
- alarms...8-67
 - auto-mode...9-20
 - auto-purge...8-31
 - axis stroke limits...9-7
- B**
- barrel heats...8-39
 - configuration...8-42
- C**
- cabinet tip forces...3-16
 - calibration mode...9-18
 - carriage...8-33
 - home position...10-3
 - controller
 - auto-mode...9-20
 - back view...4-2
 - calibration mode...9-18
 - cleaning...10-5
 - configuring...9-7
 - connecting to diagnostic computer...5-6
 - connecting to IMM...5-5
 - connecting to injection unit...5-2
 - connecting to power...5-4
 - front view...4-1
 - isolating...6-1
 - lifting...3-17
 - manual mode...9-19
 - servicing and repairing...10-5
 - setup mode...9-18
 - shutting down...6-2
 - temperature...3-15
 - unpacking...3-17
 - control system
 - troubleshooting...11-1
 - custom I/O...8-79
- D**
- digital inputs...8-79
 - directory
 - data...8-16
 - E-Multi Mini...8-13
 - machine...8-14
 - page...8-13
 - disposal...3-14
 - document release details...1-1
- E**
- electrical
 - wiring check...3-9
- F**
- file management...8-100
 - fixed data file
 - creating...9-6
 - deleting...9-7
 - saving...9-6
- G**
- grounds...3-13
- H**
- hardware
 - operation...6-1
 - overview...4-1
 - heating
 - barrel heats...8-39
 - shutting down...6-2
 - HMI (human-machine interface)...7-1. See also touch-screen (HMI)
 - hold page...8-24
 - home page...8-1
 - home position (carriage)...10-3
- I**
- IMM...3-2
 - incremental startup...8-48
 - injection
 - calibration...8-22
 - settings...8-18
 - injection molding machine...3-2
 - injection unit
 - connecting to controller...5-2
 - installation...5-1
 - I/O...8-71
- K**
- key switch...8-134
- L**
- logging in...9-1
- M**
- main page...8-1
 - main power switch...6-1
 - maintenance...10-1
 - electrical check...3-9
 - maintenance position...10-2
 - manual mode...9-19
 - Mapp cockpit...8-107
 - mold data
 - saving...10-6

- motors
 - powering...9-18
 - turning off power...9-18
- motor temperature
 - checking...11-2

P

- password...5-6
- plasticizing...8-27
- pneumatic controls...8-36
- power
 - connecting to...5-4
 - turning off...6-2
 - turning on...6-2
- preventive maintenance...10-1

R

- recipe data
 - creating...9-5
 - deleting...9-6
 - saving...9-6
- returning goods...1-1
- RJG interface...8-52
- robot jumper plug...5-3

S

- safety...3-1
- safety symbols...3-8
- screen
 - alarms...8-66
 - auto-purge...8-31
 - axis information...8-87
 - barrel heats...8-39
 - carriage...8-33
 - change log...8-115
 - counters...8-129
 - cycle information...8-123
 - data logger...8-119
 - documents...8-105
 - Euromap 67...8-94
 - HMI configuration...8-91
 - incremental startup...8-48
 - interface overview...8-131
 - log book...8-116
 - machine information...8-118
 - material data...8-125
 - plasticizing...8-27
 - production...8-109
 - RJG interface...8-52
 - schedule...8-112
 - sequence viewer...8-54
 - temperature...8-69
 - timers...8-127
 - trace...8-61
 - valve gates...8-36
 - wait timers...8-111

- SDM...8-107
- servicing
 - controller...10-5
- setup mode...9-18
- software
 - operation...8-1
 - overview...8-1
- software management
 - Mapp cockpit...8-107
- spare parts...10-5
- support...2-1
- system diagnostics manager...8-107

T

- temperature. See barrel heats; See also motor temperature; See also heating
 - controller internal...3-15
 - monitoring screen...8-69
- thermocouple
 - electrical check...11-1
- tip forces...3-16
- touchscreen (HMI)
 - cleaning...10-1
 - overview...7-1
- trace...8-61
- troubleshooting...11-1 to 11-2
 - alarms...8-66

U

- unpacking...3-17
- user
 - creating...9-3
 - deleting...9-4
- user data
 - backing up...10-9
 - exporting...9-4
 - importing...9-5
- users
 - managing...9-2

V

- valve gates...8-36
- vibrator valve
 - checking...11-1

W

- warranty...1-1
- wiring check...3-9



Scan the QR code for our global contacts: