

EcoONE

series

User Manual

version 1-3

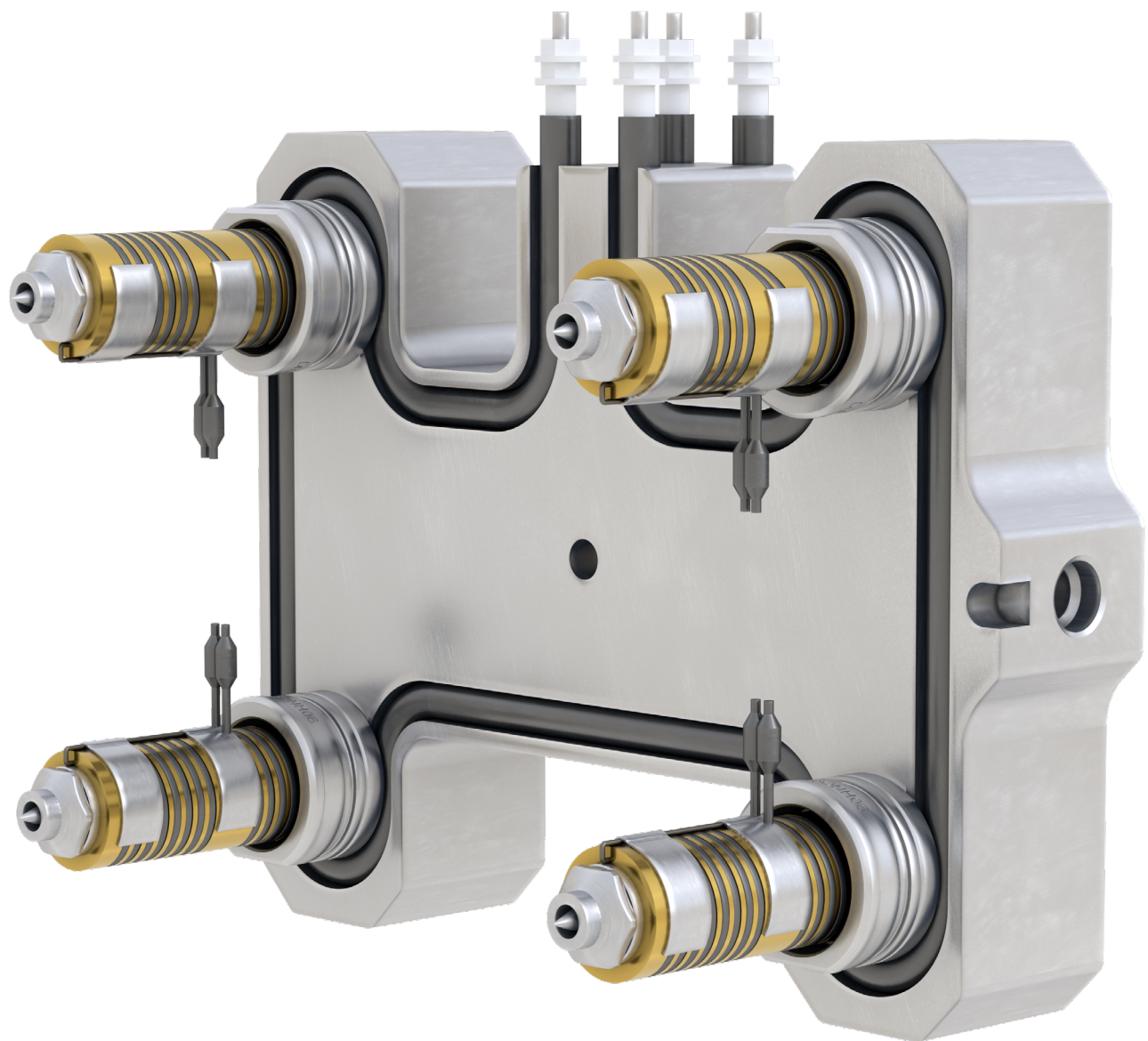

Contents

Introduction	5
Intended Use	5
Documentation.....	5
Release Details.....	5
Warranty	6
Returned Goods Policy.....	6
Movement or Resale of Mold-Masters Products or Systems	6
Copyright	6
Global Support	7
Worldwide Locations.....	7
Safety.....	8
Overview.....	9
Operational Hazards.....	12
Wiring Check	14
Lockout Safety	15
Electrical Lockout.....	16
Energy Forms and Lockout Guidelines	17
Disposal.....	18
Hot Runner Safety Hazards.....	19
Assembly Guidelines	22
General Guidelines	22
Inspection of the Manifold and Components	22
System Assembly Guidelines	23
Manifold and Component Wiring Guidelines.....	36
Ground Connection	36
Power and Thermocouple Connector Placement	36
Confirm Zone Numbering With Respect To Cavity Numbers.....	36
Wire Channels	36

Recheck Resistances of Heaters and Thermocouples	36
Adding Additional Wire to Nozzle Heater Leads	36
Adding Additional Wire to Thermocouple Leads	36
System Start-Up Guidelines	37
Before Installing the Hot Runner System	37
Manifold Filling Procedures	38
Master Inspection Sheet	40

Introduction

The purpose of this manual is to assist users in the integration, operation and maintenance of a Hot Runner. This manual is designed to cover most system configurations. If you need additional information specific to your system, or information in another language, please contact your representative or a Mold-Masters office.

Intended Use

Mold-Masters Hot Runner systems have been built to process thermoplastic material at the required temperature for injection molding and must not be used for any other purpose.

This manual is written for use by skilled persons who are familiar with injection molding machinery and their terminology. Operators should be familiar with plastic injection molding machines and the controls of such equipment. Maintenance persons should have sufficient understanding of electrical safety to appreciate the dangers of 3-phase supplies. They should know how to take appropriate measures to avoid any danger from electrical supplies.

Documentation

This manual is part of the documentation package for your order and should be referenced along with the following documents included in the package:

- The Bill of Materials (BOM). Together with the General Assembly drawing, the Bill of Materials should be referenced when ordering spare parts.
- General Assembly drawing used to integrate your Hot Runner system into the mold.
- Hot Half drawing used to integrate Hot Half into cavity plate.
- CE declaration of conformity and declaration of incorporation (EU only)

NOTE

This manual should also be used in conjunction with other relevant manuals; e.g., the Mold Machine Manual and the Controller Manual.

Release Details

When ordering this manual, please reference the document number below.

Table 1 Release Details		
Document Number	Release Date	Version
UM--EO--ENG--01	March 2024	01
UM--EO--ENG--01-1	June 2024	01-1
UM--EO--ENG--01-2	September 2025	01-2
UM--EO--ENG--01-3	February 2026	01-3

Warranty

For current warranty information please refer to the documents available from our website www.moldmasters.com/support/warranty or contact your Mold-Masters representative.

Returned Goods Policy

Please do not return any parts to Mold-Masters without pre-authorization and a return authorization number supplied by Mold-Masters. Our policy is one of continuous improvement and we reserve the right to alter product specifications at any time without giving notice.

Movement or Resale of Mold-Masters Products or Systems

This documentation is intended for use in the country of destination for which the product or system was purchased.

Mold-Masters takes no responsibility for documentation of products or systems if they are relocated or resold outside the intended country of destination, as stated on the accompanying invoice and/or waybill.

Copyright

© 2026 Mold-Masters (2007) Limited. All Rights Reserved. Mold-Masters® and the Mold-Masters logo are trademarks of Mold-Masters.

Global Support

Worldwide Locations

To find your nearest Mold-Masters office for sales or service support, please visit www.moldmasters.com/location-map or scan this QR code:



Please be aware that the safety information provided by Mold-Masters does not absolve the integrator and employer from understanding and following international and local standards for safety of machinery. It is the responsibility of the end integrator to integrate the final system, provide necessary e-stop connections, safety interlocks and guarding, to select the appropriate electrical cable for the region of use and to ensure compliance with all relevant standards.

It is the responsibility of the employer to:

- Properly train and instruct its personnel in the safe operation of equipment, including the use of all the safety devices.
- Provide its personnel with all necessary protective clothing, including a face shield and heat resistant gloves.
- Ensure the original and continuing competence of personnel caring for, setting up, inspecting and maintaining injection molding equipment.
- Establish and follow a program of periodic and regular inspections of injection molding equipment to ensure it is in safe operating condition and proper adjustment.
- Ensure that no modifications, repairs, or rebuild of portions are made to the equipment that reduces the level of safety existing at time of manufacture or remanufacture.

Overview

WARNING

Refer to all machine manuals and local regulations and codes for safety information.

The following safety hazards are most commonly associated with plastic injection molding equipment (see European Standard EN201 or American Standard ANSI/SPI B151.1). Refer to the following illustration of hazard areas when reading the Table 2 Safety Hazards.

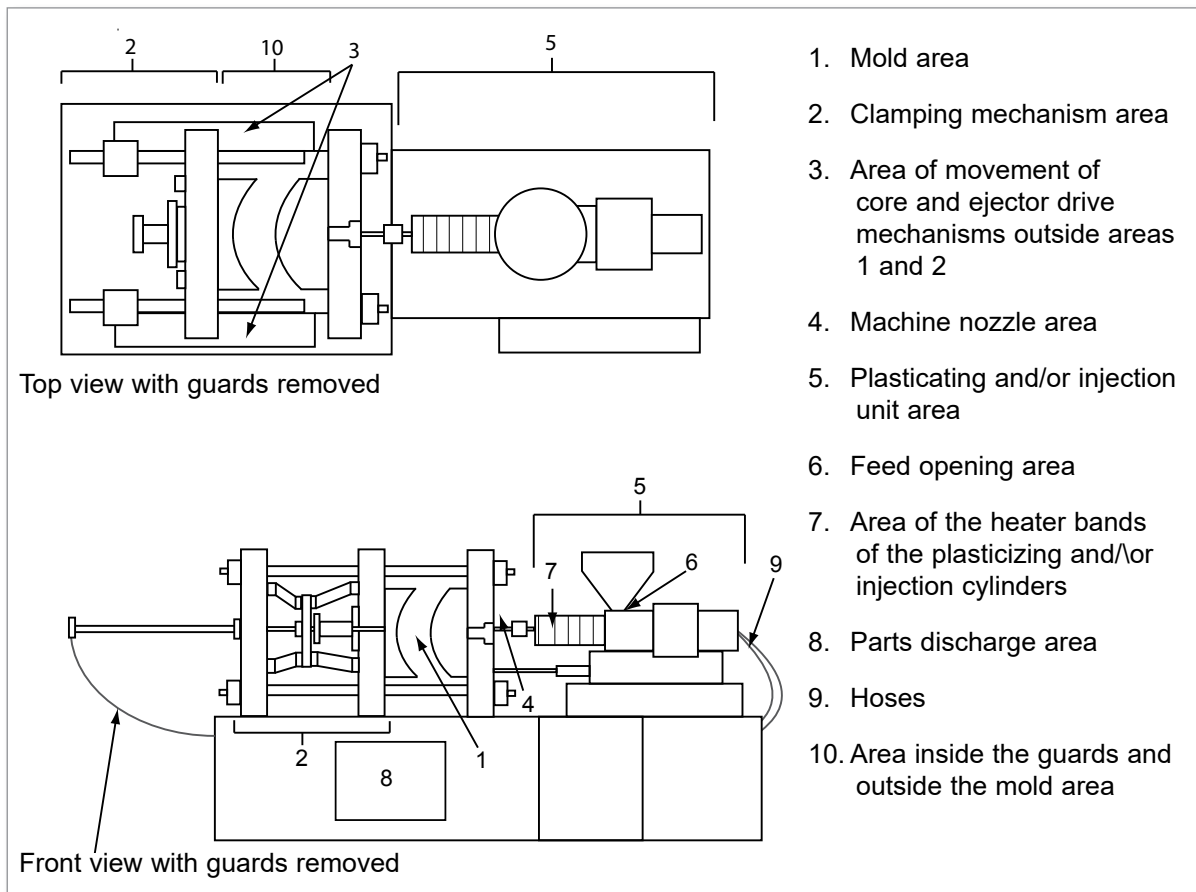

Figure 1 Injection molding machine hazard areas.

Table 2 Safety Hazards

Hazard Area	Potential Hazards
Mold Area Area between the platens. See Figure 1 area 1	Mechanical Hazards Crushing and / or shearing and / or impact hazards caused by: <ul style="list-style-type: none"> • Movement of the platen. • Movements of the injection barrel(s) into the mold area. • Movements of cores and ejectors and their drive mechanisms. • Tie bar motion. Thermal Hazards Burns and / or scalds due to operating temperature of: <ul style="list-style-type: none"> • The mold heating elements. • Plasticized material released from / through the mold.
Clamping Mechanism Area See Figure 1 area 2	Mechanical Hazards Crushing and / or shearing and/or impact hazards caused by: <ul style="list-style-type: none"> • Movement of the platen. • Movement of the drive mechanism of the platen. • Movement of the core and ejector drive mechanism.
Movement of Drive Mechanisms Outside the Mold Area and Outside the Clamping Mechanism Area See Figure 1 area 3	Mechanical Hazards Mechanical hazards of crushing, shearing and / or impact caused by the movements of: <ul style="list-style-type: none"> • Core and ejector drive mechanisms.
Nozzle Area The nozzle area is the area between the barrel and the sprue bushing. See Figure 1 area 4	Mechanical Hazards Crushing, shearing hazards, and / or impact hazards caused by: <ul style="list-style-type: none"> • Forward movement of the plasticizing and / or injection unit including nozzle. • Movements of parts of the power operated nozzle shutoff and their drives. • Over pressurization in the nozzle. Thermal Hazards Burns and or scalds due to operating temperature of: <ul style="list-style-type: none"> • The nozzle. • Plasticized material discharging from the nozzle.
Plasticizing and / or Injection Unit Area Area from the adapter / barrel head / end cap to the extruder motor above the sled including the carriage cylinders. See Figure 1 area 5	Mechanical Hazards Crushing, shearing and / or drawn-into hazards caused by: <ul style="list-style-type: none"> • Unintentional gravity movements e.g. for machines with plasticizing and / or injection unit positioned above the mold area. • The movements of the screw and / or the injection plunger in the cylinder accessible through the feed opening. • Movement of the carriage unit. Thermal Hazards Burns and or scalds due to operating temperature of: <ul style="list-style-type: none"> • The plasticizing and / or injection unit. • The heating elements e.g. heater bands. • The plasticized material and / or vapors discharging from the vent opening, feed throat or hopper. Mechanical and / or Thermal Hazard Hazards due to reduction in mechanical strength of the plasticizing and /or injection cylinder due to overheating.

Table 2 Safety Hazards	
Hazard Area	Potential Hazards
Feed Opening See Figure 1 area 6	Pinching and crushing between injection screw movement and housing.
Area of the Heater Bands of the Plasticizing and / or Injection Cylinders See Figure 1 area 7	Burns and / or scalds due to operating temperature of: <ul style="list-style-type: none"> • The plasticizing and / or injection unit. • The heating elements e.g. heater bands. • The plasticized material and / or vapors discharging from the vent opening, feed throat or hopper.
Parts Discharge Area See Figure 1 area 8	<p>Mechanical Hazards Accessible Through the Discharge Area Crushing, shearing and / or impact hazards caused by:</p> <ul style="list-style-type: none"> • Closing movement of the platen. • Movements of cores and ejectors and their drive mechanisms. <p>Thermal Hazards Accessible Through the Discharge Area Burns and or scalds due to operating temperature of:</p> <ul style="list-style-type: none"> • The mold. • Heating elements of the mold. • Plasticized material released from/through the mold.
Hoses See Figure 1 area 9	<ul style="list-style-type: none"> • Whipping action caused by hose assembly failure • Possible release of fluid under pressure that can cause injury. • Thermal hazards associated with hot fluid.
Area Inside the Guards and Outside the Mold Area See Figure 1 area 10	Crushing and / or shearing and/or impact hazards caused by: <ul style="list-style-type: none"> • Movement of the platen. • Movement of the drive mechanism of the platen. • Movement of the core and ejector drive mechanism. • Clamp opening movement.
Electrical Hazards	<ul style="list-style-type: none"> • Electric shock or burns due to contact with live conductive parts. • Electrical or electromagnetic disturbance generated by the motor control unit. • Electrical or electromagnetic disturbance that can cause failures in the machine control systems and adjacent machine controls. • Electrical or electromagnetic disturbance generated by the motor control unit.
Hydraulic Accumulators	High pressure discharge.
Power Operated Gate	Crush or impact hazards caused by the movement of the power operated gates.
Vapors and Gases	Certain processing conditions and / or resins can cause hazardous fumes or vapors.

Operational Hazards

WARNING

- Refer to all machine manuals and local regulations and codes for safety information.
- The equipment supplied is subjected to high injection pressures and high temperatures. Ensure that extreme caution is observed in the operation and maintenance of the injection molding machines.
- Only fully trained personnel should operate or maintain equipment.
- Do not operate the equipment with unconfined long hair, loose clothing or jewelry, including name badges, neckties, etc. These may get caught in the equipment and can cause death or serious injury.
- Never disable or bypass a safety device.
- Ensure that the protective guards are placed around the nozzle to prevent the material from splashing or drooling.
- A burn hazard exists from material during routine purging. Wear heat-resistant personal protective equipment (PPE) to prevent burns from contact with hot surfaces or splatter of hot material and gases.
- Material purged from machine may be extremely hot. Ensure protective guards are in place around the nozzle to prevent material from splashing. Use proper personal protective equipment.
- All operators should wear personal protective equipment, such as face shields and use heat resistant gloves when working around the feed inlet, purging the machine or cleaning the gates of the mold.
- Remove purged material from the machine immediately.
- Decomposing or burning material could result in noxious gases being emitted from the purged material, feed inlet or mold.
- Ensure proper ventilation and exhaust systems are in place to help prevent inhalation of harmful gases and vapors.
- Consult manufacturer's Material Safety Data Sheets (MSDS).
- Hoses fitted to the mold will contain high or low temperature fluids or air under high pressure. The operator must shut down and lockout these systems as well as relieving any pressure before performing any work with these hoses. Regularly inspect and replace all flexible hoses and restraints.
- Water and / or hydraulics on the mold may be in close proximity to electrical connections and equipment. Water leakage may cause an electrical short circuit. Hydraulic fluid leakage may cause a fire hazard. Always keep water and / or hydraulic hoses and fittings in good condition to avoid leaks.
- Never perform any work on the mold machine unless the hydraulic pump has been stopped.
- Check frequently for possible oil leaks / water leaks. Stop the machine and make repairs.

WARNING

- A crushing hazard exists between the nozzle and mold melt inlet during carriage forward motion.
- A possible shearing hazard exists between the edge of the injection guard and the injection housing during injection.
- The open feed port could present a hazard to a finger or a hand inserted during operation of the machine.
- The barrel, barrel head, nozzle, heater bands and mold components are hot surfaces which could result in burns.
- Keep flammable liquids or dust away from the hot surfaces as they could ignite.
- Follow good housekeeping procedures and keep floors clean to prevent slips, trips and falls due to spilled material on the work floor.
- Apply engineering controls or hearing conservation programs as necessary to control noise.
- When doing any work on the machine that requires moving and lifting the machine, ensure that lifting equipment (eyebolts, fork lift truck, cranes, etc.) will have sufficient capacity to handle mold, auxiliary injection unit or Hot Runner weight.
- Connect all lifting devices and support the machine using a crane of adequate capacity before commencing work. Failure to support the machine can result in severe injury or death.
- Mold cable from the controller to the mold must be removed before servicing the mold.

Wiring Check

CAUTION

System Mains Supply Wiring:

- Before connecting the system to a power supply, it is important to check that the wiring between the system and the power supply has been done correctly.
- Particular attention must be given to the current rating of the power supply. For example, if a controller is rated at 63 A, then the power supply must also be rated at 63 A.
- Check that the phases of power supply are wired correctly.

Controller to Mold Wiring:

- For separate power and thermocouple connections, ensure that the power cables are never connected to the thermocouple connectors and vice-versa.
- For mixed power and thermocouple connections, ensure that the power and thermocouple connections have not been wired incorrectly.

Communications Interface and Control Sequence:

- It is the customer's responsibility to verify functionality of any custom machine interface at safe speeds, prior to operating equipment in the production environment at full speed in automatic mode.
- It is the customer's responsibility to verify all required motion sequences are correct, prior to operating equipment in the production environment at full speed in automatic mode.
- Switching the machinery into Auto mode without having verified the control interlocks and motion sequence are correct, may cause damage to machinery and/or equipment.

Failure to do wiring or connections properly will result in equipment failure.

The use of Mold-Masters standard connections can help to eliminate the potential for wiring errors.

Mold-Masters Ltd. cannot be responsible for damage caused by customer wiring and/or connection errors.

Lockout Safety

WARNING

DO NOT enter the cabinet without first isolating the supplies.

High voltage and amperage cables are connected to the controller and the mold. Electrical power must be shut off and lockout / tagout procedures followed prior to installing or removing any cables.

Use lockout / tagout to prevent operation during maintenance.

All maintenance should be performed by properly trained personnel based on local laws and regulation. Electrical products may not be grounded when removed from the assembled or normal operating condition.

Ensure proper grounding of all electrical components before performing any maintenance to avoid potential risk of electrical shock.

Often power sources are inadvertently turned on or valves are opened mistakenly before maintenance work is completed, resulting in serious injuries and fatalities. Therefore, it is important to ensure that all energies are properly locked out and that they remain locked out until the work is completed.

If a lockout is not performed, uncontrolled energies could cause:

- Electrocutation from contact with live circuits
- Cuts, bruises, crushing, amputations or death, resulting from entanglement with belts, chains, conveyors, rollers, shafts, impellers
- Burns from contact with hot parts, materials or equipment such as furnaces
- Fires and explosions
- Chemical exposures from gases or liquids released from pipelines

Electrical Lockout

WARNING - READ MANUAL

Refer to all machine manuals and local regulations and codes.

NOTE

There may be more than one power source feeding the equipment and you must ensure that all sources are effectively locked out.

Employers must provide an effective lockout/tagout program.

1. Shut down machine using normal operational shutdown procedure and controls. This should be done by, or in consultation with the machine operator.
2. After ensuring that the machinery has been completely shut down, and all controls in the “off” position, open the main disconnect switch located in the field.
3. Using your own personal padlock, or one assigned by your supervisor, lock the disconnect switch in the off position. Do not lock only the box. Remove the key and retain. Complete a lockout tag and affix to the disconnect switch. Each person working on the equipment must follow this step. The lock of the person doing the work or in charge must be installed first, remain throughout and be removed last. Test the main disconnect switch and make sure it cannot be moved to the “on” position.
4. Try to start the machine using the normal operation controls and point of operation switches to make sure that the power has been disconnected.
5. Other sources of energy that could create a hazard while working on the equipment must also be de-energized and appropriately “locked-out”. This can include gravity, compressed air, hydraulics, steam and other pressurized or hazardous liquids and gases. See Table 3 Energy Forms, Energy Sources and General Lockout Guidelines.
6. When the work is completed, prior to removing the last lock, make sure the operational controls are in the “off” position so that the main disconnect switching is done under “no load”. Ensure all blocks, tools and other foreign materials are removed from machine. Also ensure that all personnel that may be affected are informed that the lock(s) will be removed.
7. Remove lock and tag, and close the main disconnect switch if permission has been given.
8. When the work has not been completed on the first shift, the next operator should install a personal lock and tag before the first operator removes the original lock and tag. If the next operator is delayed, a lock and tag could be installed by the next supervisor. Lockout procedures should indicate how the transfer is to be conducted.
9. It is important that, for their personal protection, each worker and/or fore person working in or on a machine places his/her own safety lock on the disconnect switch. Use tags to spotlight work in progress and give details of work being done. Only when the work is completed and the work permit signed off, may each worker remove his/her lock. The last lock to be removed should be that of the person supervising the lockout and this responsibility should not be delegated.

© Industrial Accident Prevention Association, 2008

Energy Forms and Lockout Guidelines

Table 3 Energy Forms, Energy Sources and General Lockout Guidelines		
Energy Form	Energy Source	Lockout Guidelines
Electrical Energy	<ul style="list-style-type: none"> Power transmission lines Machine power cords Motors Solenoids Capacitors (stored electrical energy) 	<ul style="list-style-type: none"> Turn off power at machine first (i.e., at point of operation switch), and then at the main disconnect switch for the machine. Lock and tag the main disconnect switch. Fully discharge all capacitive systems (e.g., cycle machine to drain power from capacitors) according to the manufacturer's instructions.
Hydraulic Energy	<ul style="list-style-type: none"> Hydraulic systems (e.g., hydraulic presses, rams, cylinders, hammers) 	<ul style="list-style-type: none"> Shut off, lock (with chains, built-in lockout devices, or lockout attachments) and tag valves. Bleed off and blank lines as necessary.
Pneumatic Energy	<ul style="list-style-type: none"> Pneumatic systems (e.g., lines, pressure reservoirs, accumulators, air surge tanks, rams, cylinders) 	<ul style="list-style-type: none"> Shut off, lock (with chains, built-in lockout devices, or lockout attachments) and tag valves. Bleed off excess air. If pressure cannot be relieved, block any possible movement of machinery.
Kinetic Energy (Energy of a moving object or materials. Moving object may be powered or coasting)	<ul style="list-style-type: none"> Blades Flywheels Materials in supply lines 	<ul style="list-style-type: none"> Stop and block machine parts (e.g. stop flywheels and ensure that they do not recycle). Review entire cycle of mechanical motion and ensure that all motions are stopped. Block material from moving into area of work. Blank as required.
Potential Energy (Stored energy that an object has the potential to release due to its position)	<ul style="list-style-type: none"> Springs (e.g., in air brake cylinders) Actuators Counterweights Raised loads Top or movable part of a press or lifting device 	<ul style="list-style-type: none"> If possible, lower all suspended parts and loads to the lowest (rest) position. Block parts that might be moved by gravity. Release or block spring energy.
Thermal Energy	<ul style="list-style-type: none"> Supply lines Storage tanks and vessels 	<ul style="list-style-type: none"> Shut off, lock (with chains, built-in lockout devices, or lockout attachments) and tag valves. Bleed off excess liquids or gases. Blank lines as necessary.

Disposal

WARNING

Mold-Masters declines any responsibility for personal injury or personal damage arising from reuse of the individual components, if these parts are used other than for the original and proper intended purpose.

Recycling of the materials is a priority during the disposal process.

1. Hot Runner and system components must be disconnected from the power supply fully and properly before disposal (electricity, hydraulics, pneumatics and cooling).
2. Ensure that the system to be disposed of is free from fluids. In the case of hydraulic needle valve systems, drain the oil from the lines and cylinders and dispose it in an environmentally responsible manner.
3. The electrical components are to be dismantled, separating them accordingly environmental friendly and disposed as hazardous waste if necessary.
4. Remove the wiring. The electronic components are to be disposed in accordance with the national electric scrap ordinance.
5. The metal parts are to be returned for metal recycling (waste metal and scrap trade). The instructions of the corresponding waste disposal company are to be observed in this case.

Hot Runner Safety Hazards

WARNING

- The equipment supplied is subjected to high injection pressures and high temperatures.
- Ensure that extreme caution is observed in the operation and maintenance of the Hot Runner system and the injection molding machines.
- Do not operate the equipment with unconfined long hair, loose clothing or jewelry, including name badges, neckties, etc. These may get caught by the moving belt mechanism and can cause death or serious injury.
- Never disable or bypass a safety device.
- All operators should wear personal protective equipment, such as face shields, and use heat resistant gloves when working around the feed throat, purging the machine or cleaning the gates of the mold.
- Check frequently for possible oil or water leaks. Stop the machine and make repairs.
- Do not look directly into the feed throat of a hopper. Unexpected release of resin may cause serious burns. Use a mirror. Failure to do so may cause serious injury.
- Remove purgings from the machine immediately. Never directly handle plastic purgings or drool until they have completely cooled. Purgings may appear solid but may still be hot and cause serious injury.
- Some plastics develop gases that may be dangerous to personal health. Follow the plastics supplier's recommendations. Review their material safety data sheet. Ensure the molding area is well ventilated.
- Never touch or inspect the timing belt when power is on and motor and controller are connected. Unplug the controller before any maintenance.
- Always unplug the controller before performing any maintenance work.
- Hoses fitted to the mold will contain high or low temperature fluids or air under high pressure. The operator must shut down and lockout these systems as well as relieving any pressure before performing any work with these hoses.
- Never perform any work on the mold unless the hydraulic pump has been stopped.
- High voltage and amperage cables are connected to the mold. Electric power must be shut off prior to installing or removing any cables.

WARNING

- Water and / or hydraulics on the mold may be in close proximity to electrical connections and equipment. Water leakage may cause an electrical short circuit. Hydraulic fluid leakage may cause a fire hazard. Always keep water and / or hydraulic hoses and fittings in good condition to avoid leaks.
- Make sure the lifting eyebolt, lifting chain and crane are rated to adequately support the weight of the plate(s). Failure to do so can cause a serious injury.
- All maintenance on Mold-Masters products should be performed by properly trained personnel based on local law or regulation requirements.
- Ensure proper grounding of all electrical products before performing any maintenance to avoid potential risk of electrical shock.
- Make sure the machine has been locked out and tagged out in accordance to the machine's documented procedures. Failure to do so may lead to serious injury or death.
- Check that all coolant, hydraulic and air lines as well as electrical cables will not interfere with the moving parts of the mold, machine or robot. The lines must be of sufficient length so that they will not strain or pinch when the mold halves separate.
- For water cooling nozzle jacket, coolant must be maintained with the proper mixture to prevent corrosion and circuit blockage.
- Care must be taken to ensure the nozzle terminal ends do not come in contact with the hydraulic fluid. The nozzles may short out or become damaged.
- Do not mix electrical power cables with thermocouple extension cables. They are not designed to carry the power load or list accurate temperature readings in each other's application.

CAUTION

All Mold-Masters heated components are manufactured to standards that ensure safe and reliable operation provided that the following precautions are met:

- To maximize heater element and component life, the temperature must be controlled and maintained within safe operating limits. Mold-Masters strongly recommends individual control of each heated component, including heater plates, with a reliable temperature controller that includes soft-start protection.
- Always operate the system using correctly installed “J” type thermocouples connected to a reliable temperature controller with soft-start protection.
- Avoid running the system for long periods on manual control.
- Use caution when applying power in manual mode. Use minimum heat required for the process to avoid overheating and possible damage to components.
- Always replace pinched or damaged thermocouples.
- When grouping heated components together and controlling more than one load from a single thermocouple, make sure that the components are of similar material, wattage, size and are exposed to the same thermal conditions.
- When replacing heater plates or other heated components always replace with Mold-Masters components of the same type and install as originally specified on Mold-Masters General Assembly drawings.

Assembly Guidelines

General Guidelines

To ensure success of each hot runner application, it is important that mold designers take the following factors into consideration:

1. Selection of proper steel for the nozzle gate area.
2. Proper machining of gate detail to supplied print.
3. Proper cooling of the gate area to ensure proper gate vestige and to minimize drool or stringing of the material.
4. Adequate cooling in the manifold plate, manifold retainer plate and/or support blocks (used to enclose the system), and the top clamp plate (items not included).
5. Use of the proper number and size assembly screws to provide required system support (customer to supply).
6. Allowance for adequate system cold clearance to permit later thermal expansion.

Please treat these suggestions as guidelines only. Always follow standard mold making industry practices to ensure the proper function of the mold and hot runner system.

Inspection of the Manifold and Components

Prior to system assembly, we strongly suggest you complete the following checks and establish the procedures that will facilitate proper system assembly.

7. Check the parts list to ensure that all components are of the proper part numbers, and that correct quantities are supplied.
8. Check all supplied heaters for proper resistance in ohms (Ω) and for excessive resistance to ground conditions by doing the following.
 - a. Refer to table supplied in the design package for each heater used in your system.
 - b. Note the resistance.
 - c. Measure each corresponding heater's resistance and determine if they are equivalent. (Excessive resistance to ground is defined as a reading to ground of 20,000 Ω or less.)
 - d. Heater resistance should be +10% of listed rating.
9. Manifold: Confirm that the nozzle locations are correct. Use the supplied manifold drawing to establish the shape of the clearance pocket needed in the manifold retainer plate.

The system design package sent to you by the Applications Engineering Department should be used to establish the correct installation dimensions for your system.

Manifold Plate (Customer to supply)

Note the dowel pin locations and transfer this information to your manifold plate design.

Provide the adequate number and size water lines around nozzle locations and under the manifold shape and/or around manifold pocket. The supplied drawing should be used to establish proper clearance around the manifold.

CAUTION

Proper clearance is critical. Ensure proper clearance.

Assembly Guidelines

Confirm the manifold plate thickness is as specified on the supplied drawings. This dimension is important because a change in plate thickness will affect the total stack up of the system and alter the machining dimensions of the nozzle counterbore (C-bore).

Provide a wire channel to protect and properly route wiring to the terminal box.

CAUTION

Do not run wire channels under the manifold. Manifold temperatures may cause wire damage.

The location of the terminal mounting box must be determined. Attach the terminal mounting box to the mold following the directions given in the resource guide.

A slot (vent) should be cut from the clearance pocket located toward the bottom side of the manifold retainer plate. (Recommended size: 1.5 mm deep and 26.0 mm wide)

Note the nozzle C-bore depth and transfer this value to your design. The manifold plate steel is specified on the supplied assembly drawing.

Finally, if necessary, provide proper clearance for nozzle heater leads in the underside of the manifold plate. Check the clearance and machine the clearance for the locating ring flange, if necessary.

Operational Advice

To prevent nozzle rotation during installation and future service, the EcoOne nozzles are keyed for anti-rotation. Additionally, a dowel pin is installed in the nozzle head to prevent the nozzle body from turning on the head. These two mechanisms inhibit the nozzle from turning when tightening or changing nozzle tips and retainers. The manifold plate nozzle head bores should be machined with the key as detailed in the supplied plate and model details. Failure to key the nozzle head pockets as described will allow the nozzle to rotate in the pocket, potentially damaging lead wires and complicating future service. It is also strongly recommended that all systems incorporate the use of wire channels to properly route, as well as protect, system wiring.

Clamp Plate (Customer to supply)

Identify locations of upper support pads and transfer this information to your clamp plate design. These support pads will be mounted to the underside of the clamp plate.

Provide adequate number and size water lines over the manifold shape. Transfer the matching machining dimension for the locating ring pocket from the supplied prints.

The clamp plate should be made of A36 mild carbon or 1030 medium carbon steel or equivalent.

System Assembly Guidelines

Follow the steps and procedures outlined on the following pages to ensure proper system assembly. All dimensional checks should be recorded on the Master Inspection Sheet to assist documentation for quality control and quality assurance programs. This information also will help facilitate final assembly and future questions regarding this system. Use the charts on the following pages to record the system dimensions as assembled.

NOTE

The EcoONE nozzle assemblies are “front load” type. The heaters and thermocouples, and therefore the tip/gate assemblies, must be installed on the nozzle body after the nozzle body and head assembly are position in the nozzle/retainer plate. Completing the nozzle assembly at this time will require disassembly to complete future steps in the assembly process.

Step 1: Nozzle Pre-Assembly

- a. Install the nozzle head anti-rotation dowel in the nozzle head.
- b. Pass the nozzle body through the nozzle head from the top and align the slot in the nozzle body head flange with the dowel in the head.

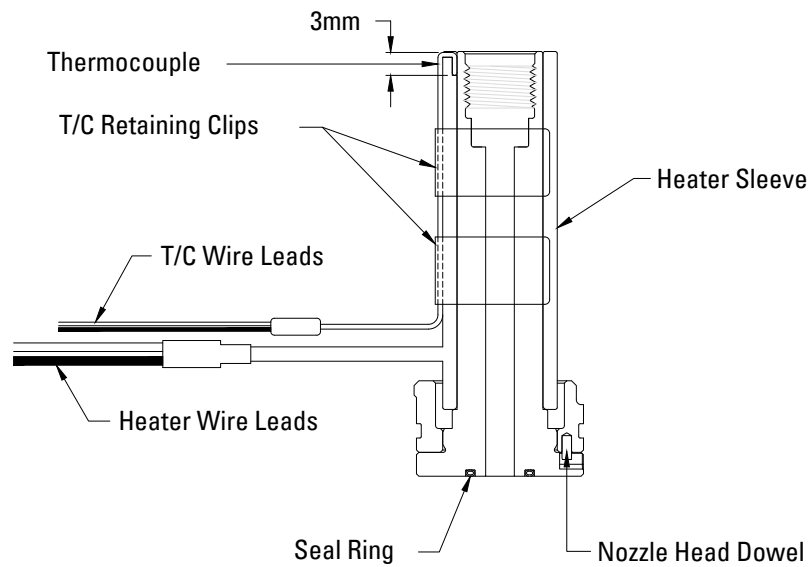

Figure 2

- c. The tip installation is required to obtain the “A” dimension in step b.
- d. Do not install the nozzle body heater or thermocouple at this time. The tips, thermocouples and heaters will have to be removed from the nozzle body during final assembly (below) so the nozzle head and body assembly can pass through the nozzle plate bores.

Gate Seal Torques

Nozzle Series	Retainer Body Thread	Torque - Open Gate Nm (ft-lb)	Torque - Valve Gate Nm (ft-lb)
EcoONE-04	M8 x 1.0	30 (22.1)	N/A
EcoONE-06	M14 x 1.5	35 (25.8)	32 (23.6)
EcoONE-08	M16 x 1.5	35 (25.8)	32 (23.6)
EcoONE-10	M18 x 1.5	35 (25.8)	32 (23.6)
EcoONE-12	M20 x 1.5	40 (29.5)	38 (28.0)
EcoONE-16	M24 x 2.0	40 (29.5)	38 (28.0)

Step 2: Nozzle Measurements

Check the “A” dimension of the nozzle assemblies to ensure this dimension is within specification and to establish a base for all other dimensions. Record the value on the Master Inspection Sheet.

NOTE

Do not finish tip / gate seal installation until after the nozzle body heater and thermocouple have been installed. The hexagonal flange of the tip/retainer holds the nozzle body heater in place.

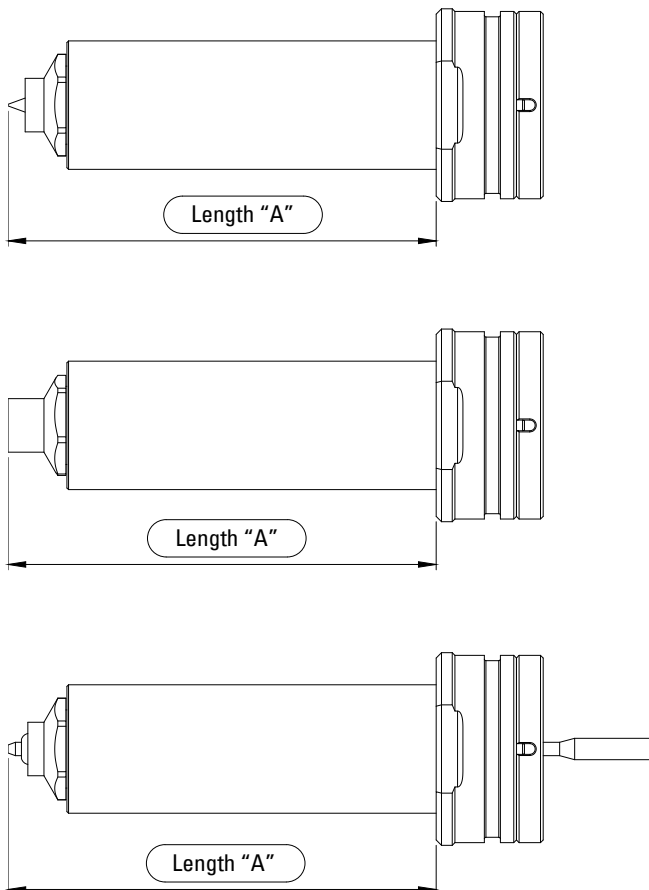

The tolerance is listed on the assembly drawings.

Figure 3 Nozzle Measurements

Assembly Guidelines

Step 3: C-Bore Depth Measurement

Inspect the manifold plate that will house the nozzle bodies for flatness. Ensure the wire channels are free of any burrs and that all directional changes incorporate generous radii. All nozzle head counterbore depths are to be $+0.025$ to -0.00 mm from the design dimension (see Figure 4 Bore Depth Measurements). Measure the counterbore in three locations to ensure flatness. Record this number as the "B" dimension on the Master Inspection Sheet.

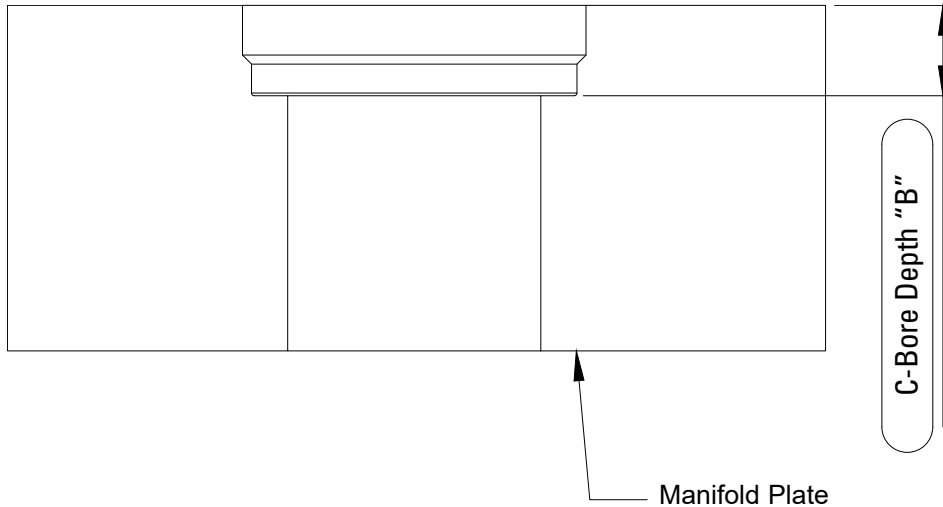

Figure 4 Bore Depth Measurements

Step 4: Head Height

Install the nozzles into their respective counterbores. Check the height from the top of the nozzle head to the top of the manifold plate. Record these dimensions as “C” on the Master Inspection Sheet (see Figure 5 Head Height).

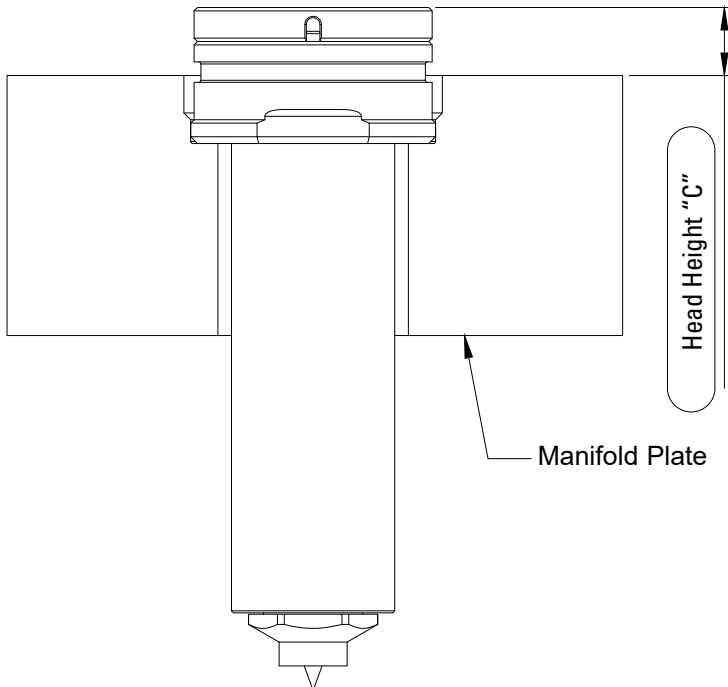

Figure 5 Head Height

Step 5: Grinding Center Support Pads

If needed, size the manifold center support to a dimension of $+0.00$ to -0.025 mm to the height of the nozzle heads found in Step #4. Grind both sides of the center support pad to ensure parallelism. (Note: The support pads are manufactured from a non-magnetic material. Fabricate a fixture plate to the grinder.) Record this dimension where indicated on the Master Inspection Sheet.

Mark the nozzle bodies on their outer diameter with the location in which they will be installed. Pay particular attention to systems that utilize different length nozzles. On multi-cavity molds, the marked number will normally reflect the cavity number, which in turn will match the temperature control zone number. Each nozzle counterbore should be numbered with its appropriate location. Use the “0” corner as a location reference.

With each manifold and component system, a wiring diagram is supplied that indicates probable locations. If the supplied diagram does not suit your needs, it is important that the diagram be remarked or a new diagram be made. A copy of the revised wiring diagram should be forwarded to the Applications Engineering Department to keep the system file current. This will facilitate troubleshooting any problems that might arise at a later time.

Assembly Guidelines

Step 6: Install Additional Lower Support Pads (if required)

If there are large distances between the manifold center support and nozzles, or between nozzles, your manifold may have been designed to have additional lower support pads. As in step 5, these additional support pads may need to be ground to the appropriate thickness to match the nozzle head height and center support height. If they are required, record the finished heights on the Master Inspection Sheet. Install the pads with the provided socket head cap screws, referring to the system general assembly drawing for the proper torque value.

Step 7: Check the Manifold Thickness

Record this dimension as “H-1” on the Master Inspection Sheet. (Do not include the heater cover plates in this measurement.) Next, test-fit the manifold block over the nozzles and dowel pins, making sure that the manifold lies flat across the nozzles with no rocking motion. Refer to the system general assembly drawing to torque the nozzle socket head cap screws.

Step 8: Properly Position the Manifold in the Manifold Plate

There are two dowel pins that align the manifold in the nozzle / manifold plate pocket. The first dowel is located at the center of the manifold. Install the tubular dowel through the center support pad. The second dowel (for anti-rotation) location is normally positioned at one of the manifold ends. The end location will be a machined slot in the bottom of the manifold that allows for expansion of the manifold as it reaches operating temperature. The length of the dowel pins should be 1.5mm less than the combined depths of their installation holes in the nozzle / manifold plate and the manifold, plus the height of the center support pad determined in Step 5. The less 1.5mm dimension ensures that the dowels do not hold the manifold off the nozzles. The use and proper location of these dowels is important to ensure nozzle drop locations line up accurately with the nozzle flow channel holes in the manifold. Install the dowel pins and check that their height meets the above criteria.

Step 9: Establish the “D” Dimension

Establish the “D” dimension by adding the average “C” dimension to the “H-1” manifold thickness. Record this dimension on the Master Inspection Sheet (see Figure 5 Head Height).

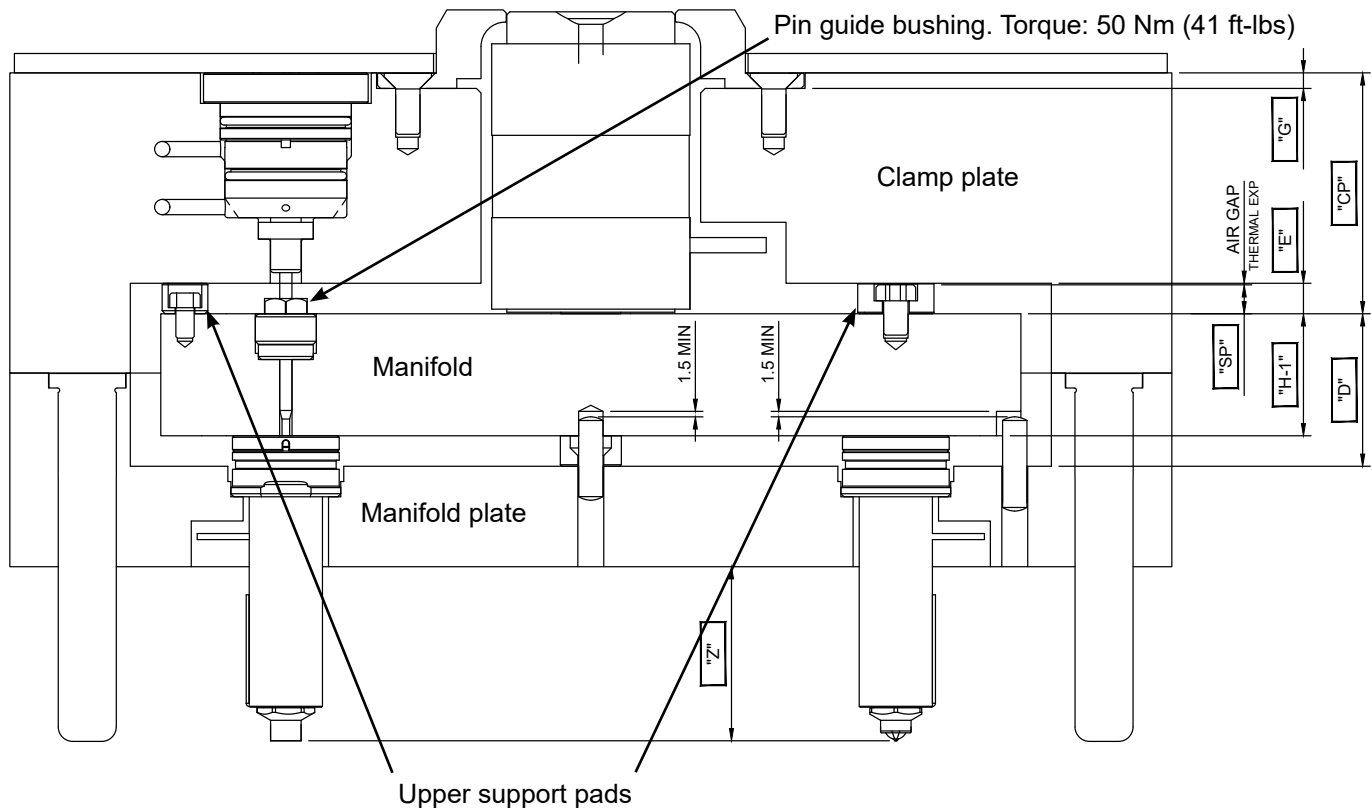

Figure 6 Locations of Support Pads and Pin Guide Bushing

Step 10: Check “E” Dimension

Check and record the dimension “E” from the bottom of the clamp plate manifold cutout surface to the center manifold surface. Record this dimension as “E” on the Master Inspection Sheet.

Step 11 Size and Install Upper Support Pads

Size and install the upper support pads into the underside of the clamp plate. (Note: The upper support pads are manufactured from a non-magnetic material. Fabricate a fixture to the grinder to hold the support pad.) This dimension will be the “E” dimension minus air gap (cold clearance) specified on the system general assembly drawing (see Figure 6 Locations of Support Pads and Pin Guide Bushing). Record this as dimension “SP” on the Master Inspection Sheet.

Valve Gate (VG) Systems

- a. Install the VG pin guide bushing and retaining screw into the threaded holes in the top of the manifold. Tighten the pin guide bushing to a torque 50 Nm (41 ft-lbs). See Figure 6 Locations of Support Pads and Pin Guide Bushing.
- b. Install the heated MEN (inlet) per the assembly drawing and route the wires through the nozzle plate wire channels to the hot runner electrical connectors.

Step 12: Install Nozzle Seal Rings

Remove the manifold from the manifold plate.

Clean nozzle head seal ring counterbores and install seal rings in the nozzle heads. Carefully install the manifold back into position in the pocket of the manifold plate without displacing the seal rings from their locations.

Step 13: Install Manifold Power Wires

Review the wiring schematic to determine how many manifold heater circuits there will be and how they are to be identified by controller zone number.

Using the supplied wire and connectors, connect the wires to the manifold heater leads and route the wires to the electrical box. Before routing the wires through the wire channels, it is helpful to place a zone number label on the wires near the electrical box end.

Step 14: Install Manifold Thermocouples

Review the wiring schematic to determine how many manifold T/C circuits there will be and how they are to be identified by controller zone number.

Using the supplied mounting hardware, fasten the thermocouple(s) to the respective location on the manifold. There are two wells for the manifold thermocouple probes. One is shallow for the top heater thermocouple, and one is deep for the bottom heater manifold.

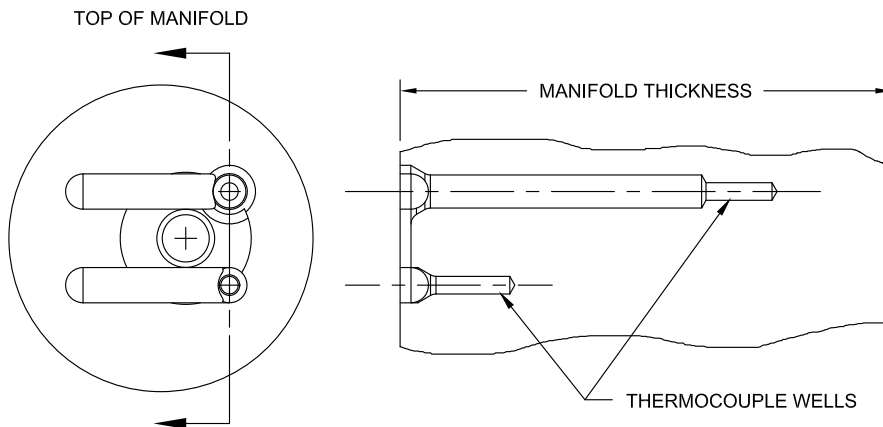

Figure 7 Locations of Support Pads and Pin Guide Bushing

Route the wires to the electrical box. Before routing the wires through the wire channels, it is helpful to place a zone number label on the wires near the electrical box end.

Step 15: Install the Inlet (Thermal Gate Systems)

Install the inlet in the top of the manifold per the assembly drawing, torquing the screws as defined on the general assembly drawing.

For EcoONE valve gate systems, the inlet is typically heated. Install the heated inlet per the assembly drawing, torquing the screws as defined on the general assembly drawing, and route the inlet heater power and thermocouple wires through the nozzle plate wire channels to the electrical terminal box.

Step 16: Install the Drool Ring (Thermal Gate Systems)

If applicable, install the drool ring around the inlet per the general assembly drawing. The drool ring is not required and may or may not have been purchased with the system.

Step 17: Install the VG Pin Guide Bushings (Valve Gate Systems)

- Install the VG pin guide bushing and retaining screw into the threaded holes in the top of the manifold. Tighten the pin guide bushing to a torque 50 Nm (41 ft-lbs). See Figure 6 Locations of Support Pads and Pin Guide Bushing.
- Install the heated MEN (inlet) per the assembly drawing and route the wires through the nozzle plate wire channels to the hot runner electrical connectors.

Step 18: Fasten Top Clamp Plate to the Manifold Plate

Test fit the top clamp plate to check for interference between the upper support pads and any manifold components or wiring. Measure the locating ring cut-off dimension depth "G" (Figure 7) and record.

CAUTION

Be careful not to pinch the system wiring.

Carefully assemble the clamp plate to the manifold plate.

Refer to the system general assembly drawing to torque the assembly screws that hold the top clamp plate and manifold plate together.

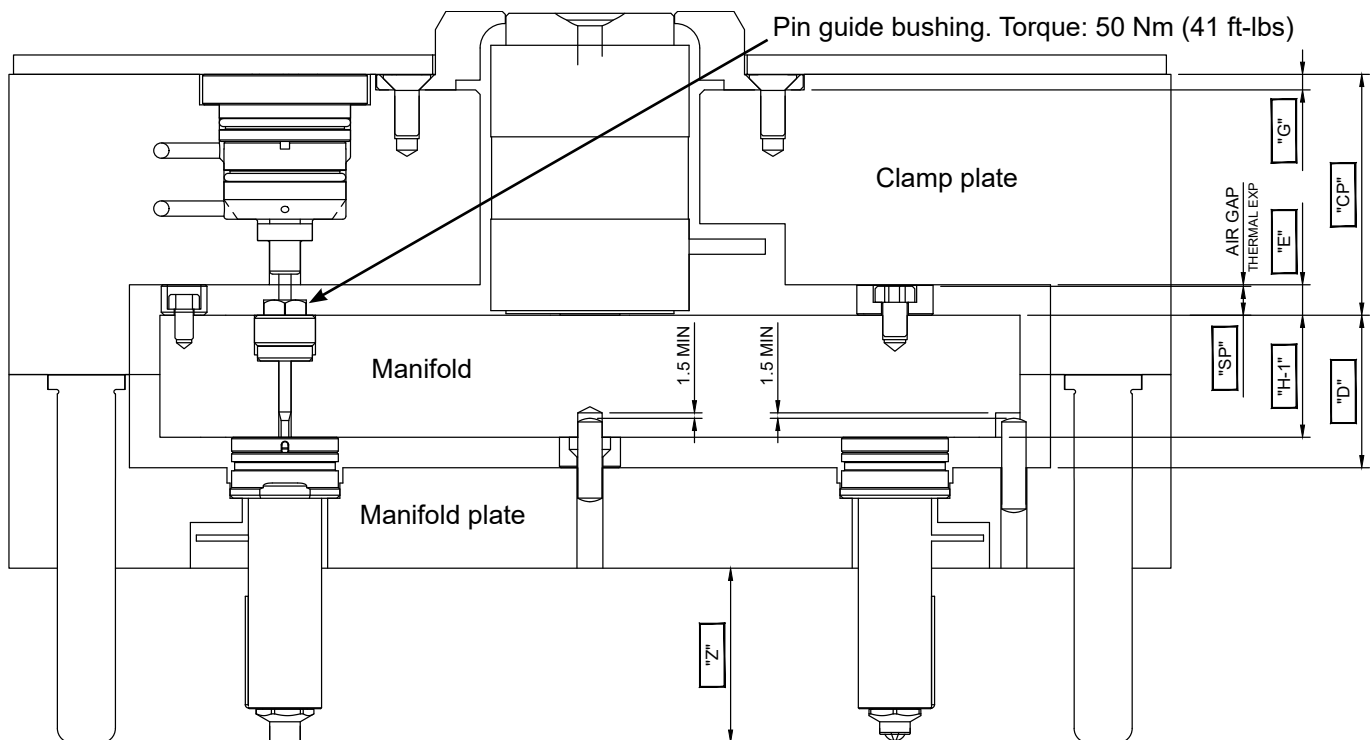
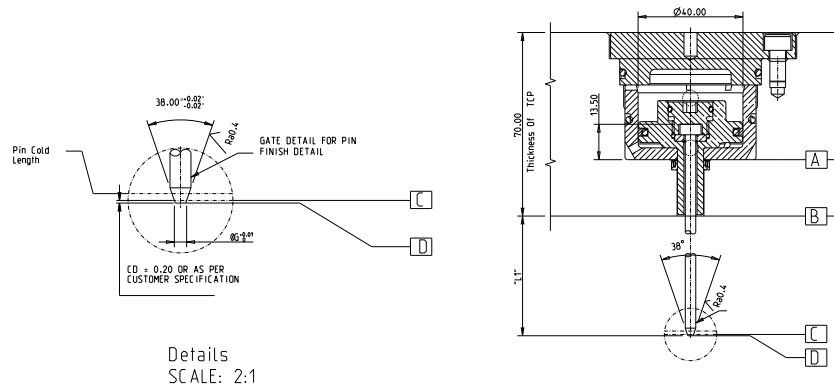

Figure 8

Step 18: Install Valve Gate Actuators (Valve Gate Systems)

- a. Lubricate actuator body and cover O-rings with a quality O-ring lubricant. Install valve gate actuator in the top clamp plate. Actuator cover bolts should be torqued to 13 Nm (9.6 ft-lbs).
- b. Cut and Install Valve Pins
 - i. Measure the distances AC and BC.



- ii. Calculate heat expansion factor using the following equation: $F_h = (\text{Processing temp.} - \text{Mold temp.}) * 0.000115$.
- iii. Calculate the heat expansion (HE) of the valve pin using the equation: $HE = \text{Distance BC} * \text{Heat expansion factor} = BC * F_h$
- iv. Calculate the Valve pin total length "L":
 - $L = 13.5 + AB + L1 + CD - HE$ (total length < 350 mm)
 - $L = 13.5 + AB + L1 + CD - HE + 0.2$ (total length > 350 mm)
- v. Cut the valve pin to the calculated length L.
- vi. Grind the valve pin tip to an angle of 19° per side (38° inclusive).
- vii. Lap the tip of the pin into the land using a lapping guide bushing or the valve bushing as a lapping guide. Avoid getting the lapping paste (400 - 600 grit) in the valve bushing bore.
- viii. Assemble the hydraulic unit.

Once molding begins, the valve gate actuator tuning pad can be ground to make the final pin length adjustments if the gate vestige needs to be modified.

Step 19: Complete Nozzle Assembly and Installation

Rotate the hot half assembly so the nozzles face upward. See Figure 9 on page 33.

- a. If the nozzle tips / gate seals were installed in Step 1, remove them now.
- b. Install the nozzle body heaters by sliding them over the nozzle body. The power wire lead is to be toward the nozzle head.
- c. Before routing the heater power wires through the wire channels in the nozzle / manifold plate, it is helpful to place a zone number label on the leads near the electrical connector box end.
- d. Install the nozzle thermocouples (T/C). The nozzles T/C's are supplied as a straight probe. It is necessary to bend a small "hook" (3 mm long) at the end of the probe, which will slide into the groove cut into the brass heater sleeve near the tip of the nozzle. The groove is in line with the heater power wires. Run the probe straight toward the nozzle head and bend the thermocouple lead wires so they

exit away from the nozzle with the heater power wires. Install one or two (depending on nozzle length) nozzle T/C retention clips to hold the thermocouple probe in position, and close to the heater sleeve.

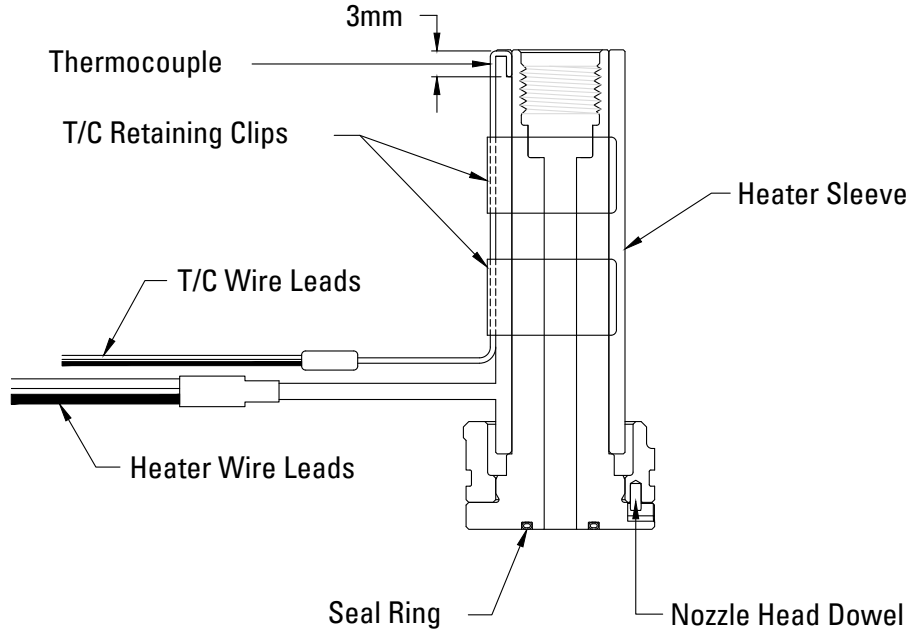

Figure 9

e. Before routing the T/C wires through the wire channels in the nozzle / manifold plate, it is helpful to place a zone number label on the leads near the electrical connector box end.

f. Install the nozzle tips / gate seals and torque per the following table.

Nozzle Series	Retainer Body Thread	Torque - Open Gate Nm (ft-lb)	Torque - Valve Gate Nm (ft-lb)
EcoONE-04	M8 x 1.0	30 (22.1)	N/A
EcoONE-06	M14 x 1.5	35 (25.8)	32 (23.6)
EcoONE-08	M16 x 1.5	35 (25.8)	32 (23.6)
EcoONE-10	M18 x 1.5	35 (25.8)	32 (23.6)
EcoONE-12	M20 x 1.5	40 (29.5)	38 (28.0)
EcoONE-16	M24 x 2.0	40 (29.5)	38 (28.0)

g. Per the general assembly drawing, apply a good quality high temperature anti-seize lubricant to the threads of the tip (or tip retainer) before final assembly.

h. Neatly route all heater power wires and T/C wires through the manifold plate wire channels to the electrical connector box and terminate per the wiring diagram.

If a heated inlet is installed, also be sure to route and terminate its heater and thermocouple wires as well as the manifold heaters and thermocouple wires.

Do not pull wires tight around corners of the channel. It is also recommended to leave some service loop length on all wires in the electrical connector box to make future service easier.

Step 20: Confirm Nozzle Length / "Z" Dimension

Check the "Z-1" dimension (see the following figure) to get the "Z" dimension, which is the sum of the dimension "Z-1" and the air gap. Record "Z" on the Master Inspection Sheet. These dimensions should fall within $\pm 0.025\text{mm}$ of each other.

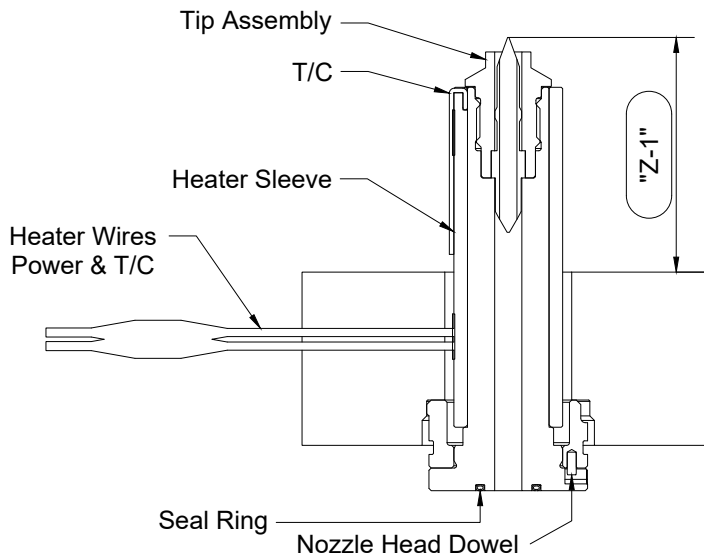

Step 21: Hot Half Final Assembly

- Install all assembly screws and torque down as required per the general assembly drawings.
- Re-check all wiring for continuity, check all power circuits for shorts to ground, prepare for power test of the hot half.

Step 22: Power Test and Thermal Expansion Considerations

The initial power test of the hot runner heaters does not have to be performed at the processing temperature noted on the general assembly drawings. The heater and related thermocouple response should be verifiable at temperatures much lower than processing temperature (example $60^{\circ}\text{C}/150^{\circ}\text{F}$).

When the system is tested at the processing temperatures it was designed for, follow this hot runner start-up procedure to ensure thermal expansion happens in the correct order to properly set the nozzle seal rings. Improper start-up of any hot runner system is a common error, resulting in plastic leaks from scrape marks or scoring on the manifold. Be sure, particularly with a new system, to heat up the manifold first and allow it to expand, then turn on the nozzle zones. This will allow the nozzle heads to expand and contact the manifold after the manifold has already reached the necessary operating temperature and expanded to its operating size. Failure to do so could lead to burr creation between the manifold and one or more of the nozzle head surfaces. The EcoONE nozzles have seal rings between the manifold and nozzle head, making burr creation more likely if this procedure is not followed.

The EcoONE hot runner system was designed using a single melt temperature to calculate the expected average thermal expansion within the system. If a processing or mold cooling temperature is used that is significantly different than what was used when designing the hot runner system, the system thermal expansion may be less than or greater than what was originally calculated. It is the responsibility of the end-user/molder to use appropriate temperature settings. Refer to the general assembly drawing provided with the hot runner system.

Heat-Up

1. Set the manifold system temperature controller zones to the correct processing/setpoint temperature for the material being molded (reference the general assembly drawing). Allow the manifold to soak for 20-30 minutes once setpoint temperature has been reached.
2. Set the nozzles and inlet heater (if equipped) controller zones to the correct processing/setpoint temperatures. Allow the nozzle and inlet (if heated) to soak for 5-10 minutes once setpoint temperature has been reached.
3. Check the nozzle tips/retainer (gate seal) torque to make sure it is still the value listed in the aforementioned table.

Manifold and Component Wiring Guidelines

Ground Connection

A ground connection must exist between the hot runner system (mold base) and the temperature control system. This is accomplished via the mold power cable, which contains a ground wire (green) provided on the connector.

WARNING

To prevent electrical shock and ensure personal safety, the ground wire should be connected to the mold base or the terminal box.

Power and Thermocouple Connector Placement

Do not place the mold's power or thermocouple plugs in any area where they will be exposed to extreme temperature or humidity.

Confirm Zone Numbering With Respect To Cavity Numbers

Wire Channels

Use wire channels to ensure that wiring for nozzle and manifold (including thermocouples) is routed away from the manifold. Use retainer clips to hold the wiring in the channels to prevent wires from being cut or pinched during final assembly.

Recheck Resistances of Heaters and Thermocouples

Compare to previous results. If values are different, troubleshoot the system. Record these values on the Master Inspection Sheet, and compare to those values provided on your design.

Adding Additional Wire to Nozzle Heater Leads

If additional lead length is required, use the same type and size of wire. Where the connection is made, a non-insulated butt connector should be used and taped over with a high-temperature insulating tape, or similar material. Be sure to test all connections before final assembly.

Adding Additional Wire to Thermocouple Leads

If additional lead length is required, use only type "J" thermocouple wire (positive [+] white, negative [-] red). The wire should be double-length stripped, folded for proper silver-solder connection, and taped over with a high-temperature insulating tape, or similar material.

NOTE

In the event that multiple zones are ganged together to minimize the required number of control zones, it will be necessary to use one pair of thermocouple wires per ganged set of nozzles. Run other thermocouple leads into the terminal box, insulating and identifying each for use as spares if required at a later date.

Before Installing the Hot Runner System

Perform the following checks before installing the hot runner system into the press.

1. With the system properly grounded, execute an electrical check of each control zone for both power and thermocouple connections. Check the heater leads for continuity. The resistance checked to ground of all heater leads must be greater than 20,000 Ohms.
2. Check each thermocouple circuit for continuity. It is also important to check for continuity between thermocouples and heater elements. There should be no circuit between the heater element and the thermocouple.
3. Bench test the unit with the temperature controller set at 149°C. Ensure all heaters come up to the desired set point. If desired set point is not reached, troubleshoot the system.
4. When the mold is installed in the press and all water connections are made, plug the power and thermocouple cables into the mold terminal box.
5. Set the temperature controller to the correct processing temperature for the material being molded. This value is usually 11–18°C higher than the front barrel temperature setting.

Operational Advice: Allow all heaters to go through a moisture dryout process.

6. Bring the system up to the correct processing temperature. Turn on mold water (cooling) and close the mold. Extremely cold water is not necessary. A water temperature of 37.8°C should keep the “A” side of mold from expanding at a different rate than the “B” side of the mold.

CAUTION

Improper start-up of any hot runner system is a common error, resulting in plastic leaks from scrape marks or scoring on the manifold. Make sure, particularly with a new system, to heat up the manifold first and allow it to heat soak expand, and then turn on the nozzle zones. This will allow the nozzle heads to expand and contact the manifold after the manifold has already reached the necessary operating temperature. Failure to do so could lead to burr creation between the manifold and one or more of the nozzle head surfaces. The seal rings between the manifold and nozzle heads increase the likelihood of burr creation if this sequence for first time heat-up is not followed.

7. When the hot runner system has reached set point and is normalized, the temperature controller should indicate no deviation between set point and process temperatures.
8. Make sure that the machine nozzle orifice is as large as, but not larger than, the nozzle seat orifice on the manifold. This will allow maximum throughput to the hot runner molding system and the mold cavities.
9. Be certain that the nozzle radius on the machine barrel matches the nozzle seat radius on the manifold to prevent drooling. This should ensure a leak-proof seal.
10. Purge the barrel to ensure stable material enters the manifold.
11. Move the machine nozzle into position against the manifold nozzle seat.

Manifold Filling Procedures

WARNING

Never inject plastic through the hot runner system with the mold open.

CAUTION

Make sure you wear proper safety equipment such as gloves and face shield at all times.

Never use a torch to open frozen-off gates. This may damage tips, gate detail, or the mold itself.

If you insert anything into the gate or tip to clear it, you must first back the machine nozzle away from the tool. Check for drool out the back of the manifold before you start. Drool here will indicate little or no pressure in the manifold.

During the first 15 minutes of operation, check system for leaks. Loss of shot size could be an indication of leakage.

Input voltage to the temperature control system must not be less than 208 VAC.

Voltages less than 240 VAC will require an extended time to bring the system up to its proper operating temperature. Lower voltages decrease effective wattage. For example: at 208 VAC, the effective wattage is 28% less than that at 240 VAC.

12. Ensure that the machine's nozzle tip is properly seated on the manifold nozzle seat.
13. Set machine back pressure to 300 – 500 psi.
14. Run the extruder until material flows through all nozzle orifices (gates). Run for an additional 5 –15 seconds. Then clear gates and all mold surfaces of material. If the machine nozzle will not stay against the tool, see the notes following these instructions.
15. Move the sled back and decrease back pressure to normal setting.
16. Set decompression/suck back at a minimum 12 mm to control drool.
17. Set molding parameters.
18. Move sled forward.
19. Start the molding process.
20. Check the system for leaks.

Troubleshooting

If the system will not start up, throttle down or shut off water to the "A" plate. Water to the manifold plate should remain on.

If the machine will not extrude with the tool open, close the tool, jog the screw forward, open the tool, close the tool, and jog the screw forward again.

If the machine nozzle will not stay against nozzle seat, proceed with caution. Set injection forward pressure to 200 psi. Set injection speed to slow, making sure the system is up to temperature. Move the sled into the tool and cautiously jog injection forward until material flows through gates. If necessary, raise the injection

pressure in steps up to, but not exceeding, 500 psi. Clear gates and all mold surfaces of material. Finally, start the molding process.

Drops	Nozzle Dimensions					Heater & Thermocouple (T/C) Ohm Measurement:	
	A	B	C	D**	Z	Heater	T/C
Nozzle #1							
Nozzle #2							
Nozzle #3							
Nozzle #4							
Nozzle #5							
Nozzle #6							
Nozzle #7							
Nozzle #8							
Nozzle #9							
Nozzle #10							
Nozzle #11							
Nozzle #12							
Nozzle #13							
Nozzle #14							
Nozzle #15							
Nozzle #16							

*Head Height

** Average "C" plus "H-1" dimension

Assembly Date

Quote No.

Assembled By

Manifold "H-1" Thickness

Center Support Height

Dimension "E"

Dimension "SP"

Locating Ring Cut-Off Dimension "G"



Scan the QR code for our global contacts: