

Dura[®] PLUS

User Manual

version 3



Contents

Section 1 - Introduction	1-1
1.1 Intended Use	1-1
1.2 Documentation	1-1
1.3 Document Release Details	1-1
1.4 Warranty	1-2
1.5 Returned Goods Policy.....	1-2
1.6 Movement or Resale of Mold-Masters Products or Systems	1-2
1.7 Copyright	1-2
1.8 Units of Measure and Conversion Factors	1-3
 Section 2 - Global Support	 2-1
2.1 Worldwide Locations	2-1
 Section 3 - Safety.....	 3-1
3.1 Safety Hazards	3-2
3.2 Operational Hazards.....	3-5
3.3 General Safety Symbols.....	3-7
3.4 Wiring Check	3-8
3.5 Lockout Safety.....	3-9
3.5.1 Electrical Lockout.....	3-10
3.5.2 Energy Forms and Lockout Guidelines.....	3-11
3.6 Disposal.....	3-12
3.7 Dura Plus Safety Hazards	3-13
 Section 4 - Preparation	 4-1
4.1 Tools Required.....	4-1
4.2 Screw Lengths.....	4-2
4.3 Unpacking.....	4-2
4.4 Cleaning	4-3
 Section 5 - Assembly	 5-1
5.1 Typical Dura Plus System.....	5-1
5.2 Pre-Assembly Checks of Gate Seals and Nozzle	5-2
5.3 Assembly of Gate Seals to Nozzle	5-3
5.4 Thermocouple Installation for 01 Nozzle	5-4
5.4.1 02 Nozzle Flange Assembly	5-6
5.5 Sub-Manifold Assembly for Drop-In System.....	5-9
5.5.1 Install Valve Disk (Valve Disk Design)	5-9
5.5.2 Install Valve Disk with Nozzle and Heater Sleeves.....	5-12
5.5.3 Hydraulic System Installation.....	5-15
5.6 Actuator Assembly	5-17
5.6.1 Install Pneumatic Actuator Assembly.....	5-17
5.6.2 Pneumatic System Installation.....	5-21
5.6.3 Install Hydraulic Actuator Assembly.....	5-25
5.7 Install Heater Plates	5-31

5.7.1 Install Heater Plate Thermocouple	5-31
5.7.2 Install Heater Plates.....	5-32
5.8 Tubular Heater Installation and Replacement	5-33
5.8.1 Storage	5-33
5.8.2 Remove a Heater Element	5-34
5.8.3 Install a New Heater Element	5-34
5.9 Bridge Assembly.....	5-37
5.9.1 Installation of Inlet Components	5-37
5.9.2 Heated Back Plate Installation.....	5-37
5.9.3 Inlet Extension with Heater Sleeves	5-38
5.9.4 Wiring Channel	5-42
5.10 Sub-Manifold Wiring	5-44
5.10.1 Power Wiring	5-44
5.10.2 Thermocouple Wiring.....	5-45
5.10.3 Prepare to Wire the Bridge	5-45
5.10.4 Wiring Channel Installation	5-46
5.10.5 Electrical Box.....	5-48
5.10.6 Solenoid Valve Wiring.....	5-48
Section 6 - SeVG+ Actuator	6-1
Section 7 - Accu-Line	7-1
7.1 Accu-Line with Valve Insert - Assembly	7-2
Section 8 - Electrical Testing	8-1
8.1 Safety	8-1
8.2 Wiring Check	8-1
8.3 Ground Shorts Test.....	8-2
8.4 Thermocouple Continuity Test	8-2
8.5 Pinch Point Test.....	8-3
8.6 Heater Continuity.....	8-3
8.7 Thermocouple Wiring Guidelines	8-3
8.8 Heating Test with a Temperature Controller.....	8-4
8.9 Retesting	8-4
Section 9 - Installation	9-1
9.1 Prior to Assembly.....	9-1
9.2 System Installation	9-1
9.2.1 Assembling a Water-Cooled Nozzle Jacket.....	9-1
9.2.2 Install Sub-Manifold Assembly.....	9-2
9.2.3 Install Manifold Locator and Anti-Rotation Dowel	9-2
9.2.4 Install Bridge Assembly.....	9-3
9.2.5 Final Installation Steps.....	9-4
Section 10 - Startup and Shutdown	10-1
10.1 Pre-Startup	10-1
10.2 Startup	10-2
10.2.1 Standard Hot Runner Systems	10-2
10.2.2 Stack Mold Systems	10-3

10.3 Shutdown..... 10-3

 10.3.1 Standard Hot Runner Systems 10-3

 10.3.2 Stack Mold System 10-4

Section 11 - Maintenance 11-1

 11.1 Repair Kits and Crimping Tools..... 11-1

 11.2 Terminal End Removal..... 11-2

 11.3 Terminal Assembly 11-3

 11.4 Heater Plate Power Lead Replacement 11-6

 11.4.1 Removal..... 11-6

 11.4.2 Installation..... 11-6

 11.5 Gate Seal Maintenance 11-7

 11.6 Multi-Cavity Systems 11-7

 11.7 Gate Seal Removal..... 11-8

 11.8 Gate Seal Replacement..... 11-9

 11.9 Checking Nozzle Tip Height..... 11-11

 11.10 Nozzle Thermocouple Removal..... 11-12

 11.11 Torque Settings 11-12

 11.11.1 Gate Seal Torque Settings 11-12

 11.11.2 System and Plate Screw Torques 11-13

Section 12 - Troubleshooting 12-1

Section 13 - Glossary of Terms 13-1

Index I

Section 1 - Introduction

The purpose of this manual is to assist users in the integration, operation and maintenance of a Dura Plus Hot Runner. This manual is designed to cover most system configurations. If you need additional information specific to your system, or information in another language, please contact your representative or a Mold-Masters office.

1.1 Intended Use

Mold-Masters Dura Plus Hot Runner systems have been built to process thermoplastic material at the required temperature for injection molding and must not be used for any other purpose.

This manual is written for use by skilled persons who are familiar with injection molding machinery and their terminology. Operators should be familiar with plastic injection molding machines and the controls of such equipment. Maintenance persons should have sufficient understanding of electrical safety to appreciate the dangers of 3-phase supplies. They should know how to take appropriate measures to avoid any danger from electrical supplies.

1.2 Documentation

This manual is part of the documentation package for your order and should be referenced along with the following documents included in the package:

- The Bill of Materials (BOM). Together with the General Assembly drawing, the Bill of Materials should be referenced when ordering spare parts.
- General Assembly drawing used to integrate your Hot Runner system into the mold.
- Hot half drawing used to integrate Hot Half to cavity plate if applicable.
- CE declaration of conformity and declaration of incorporation (EU only)



NOTE

This manual should also be used in conjunction with other relevant manuals; e.g., the Mold Machine Manual and Controller Manual.

1.3 Document Release Details

When ordering this manual, please reference the document number below.

Table 1-1 Release Details		
Document Number	Release Date	Version
DP-UM-EN-00-02-2	July 2019	02-2
DP--UM--EN--00--02-3	May 2021	02-3
DP--UM--EN--00--02-4	December 2024	02-4
UM--DP--ENG--02-5	July 2025	02-5
UM--DP--ENG--03	June 2026	03

1.4 Warranty

For current warranty information please refer to the documents available from our website www.moldmasters.com/support/warranty or contact your Mold-Masters representative.

1.5 Returned Goods Policy

Please do not return any parts to Mold-Masters without pre-authorization and a return authorization number supplied by Mold-Masters Limited.

Our policy is one of continuous improvement and we reserve the right to alter product specifications at any time without giving notice.

1.6 Movement or Resale of Mold-Masters Products or Systems

This documentation is intended for use in the country of destination for which the product or system was purchased.

Mold-Masters takes no responsibility for documentation of products or systems if they are relocated or resold outside the intended country of destination, as stated on the accompanying invoice and/or waybill.

1.7 Copyright

© 2026 Mold-Masters (2007) Limited. All Rights Reserved. Mold-Masters® and the Mold-Masters logo are trademarks of Mold-Masters..

1.8 Units of Measure and Conversion Factors



NOTE

The dimensions given in this manual are from original manufacturing drawings.

All values in this manual are in S.I. units or subdivisions of these units. Imperial units are given in parenthesis immediately after the S.I. units.

Table 1-2 Units of Measure and Conversion Factors		
Unit	Abbreviation	Conversion value
bar	Bar	14.5 psi
in.	Inch	25.4 mm
kg	Kilogram	2.205 lb
kPa	Kilopascal	0.145 psi
lb	Pound	0.4536 kg
lbf	Pound force	4.448 N
lbf.in.	Pound force inch	0.113 Nm
min	Minute	
mm	Millimeter	0.03937 in.
mΩ	Milliohm	
N	Newton	0.2248 lbf
Nm	Newton meter	8.851 lbf.in.
psi	Pound per square inch	0.069 bar
psi	Pound per square inch	6.895 kPa
rpm	Revolutions per minute	
s	Second	
°	Degree	
°C	Degree Celsius	0.556 (°F -32)
°F	Degree Fahrenheit	1.8 °C +32

Section 2 - Global Support

2.1 Worldwide Locations

To find your nearest Mold-Masters office for sales or service support, please visit

www.moldmasters.com/location-map or scan this QR code:



Section 3 - Safety

Please be aware that the safety information provided by Mold-Masters does not absolve the integrator and employer from understanding and following international and local standards for safety of machinery. It is the responsibility of the end integrator to integrate the final system, provide necessary e-stop connections, safety interlocks and guarding, to select the appropriate electrical cable for the region of use and to ensure compliance with all relevant standards.

It is the responsibility of the employer to:

- Properly train and instruct its personnel in the safe operation of equipment, including the use of all the safety devices.
- Provide its personnel with all necessary protective clothing, including a face shield and heat resistant gloves.
- Ensure the original and continuing competence of personnel caring for, setting up, inspecting and maintaining injection molding equipment.
- Establish and follow a program of periodic and regular inspections of injection molding equipment to ensure it is in safe operating condition and proper adjustment.
- Ensure that no modifications, repairs, or rebuild of portions are made to the equipment that reduces the level of safety existing at time of manufacture or remanufacture.

3.1 Safety Hazards

WARNING



Refer to all machine manuals and local regulations and codes for safety information.

The following safety hazards are most commonly associated with plastic injection molding equipment (see European Standard EN201 or American Standard ANSI/SPI B151.1).

Refer to the illustration of hazard areas below when reading the Table 3-1 Safety Hazards on page 3-3

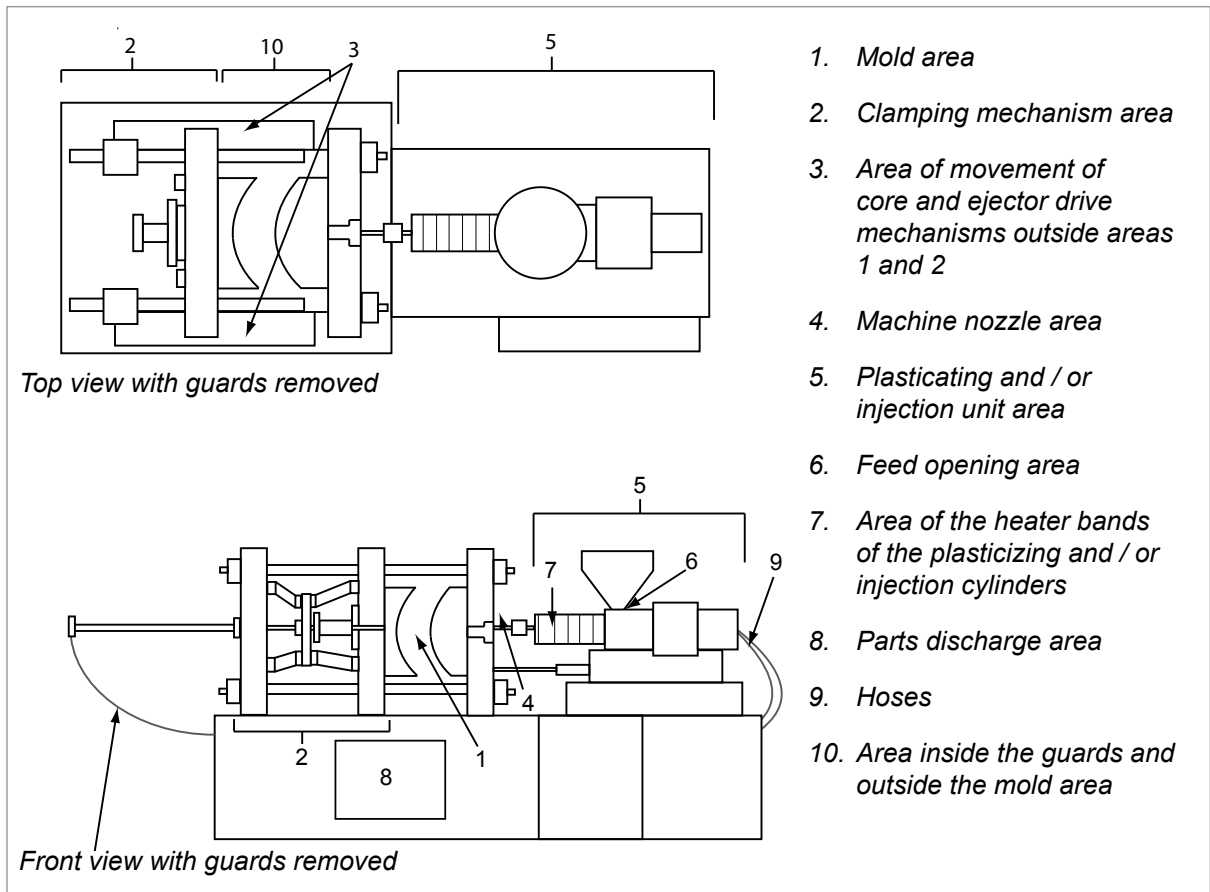

Figure 3-1 Injection molding machine hazard areas

Safety Hazards - continued

Table 3-1 Safety Hazards	
Hazard Area	Potential Hazards
<p>Mold Area Area between the platens See Figure 3-1 area 1</p>	<p>Mechanical Hazards Crushing and / or shearing and / or impact hazards caused by:</p> <ul style="list-style-type: none"> • Movement of the platen. • Movements of the injection barrel(s) into the mold area. • Movements of cores and ejectors and their drive mechanisms. • Tie bar motion. <p>Thermal Hazards Burns and / or scalds due to operating temperature of:</p> <ul style="list-style-type: none"> • The mold heating elements. • Plasticized material released from / through the mold.
<p>Clamping Mechanism Area See Figure 3-1 area 2</p>	<p>Mechanical Hazards Crushing and / or shearing and/or impact hazards caused by:</p> <ul style="list-style-type: none"> • Movement of the platen. • Movement of the drive mechanism of the platen. • Movement of the core and ejector drive mechanism.
<p>Movement of Drive Mechanisms Outside the Mold Area and Outside the Clamping Mechanism Area See Figure 3-1 area 3</p>	<p>Mechanical Hazards Mechanical hazards of crushing, shearing and / or impact caused by the movements of:</p> <ul style="list-style-type: none"> • Core and ejector drive mechanisms.
<p>Nozzle Area The nozzle area is the area between the barrel and the sprue bushing. See Figure 3-1 area 4</p>	<p>Mechanical Hazards Crushing, shearing hazards, and / or impact hazards caused by:</p> <ul style="list-style-type: none"> • Forward movement of the plasticizing and / or injection unit including nozzle. • Movements of parts of the power operated nozzle shutoff and their drives. • Over pressurization in the nozzle. <p>Thermal Hazards Burns and or scalds due to operating temperature of:</p> <ul style="list-style-type: none"> • The nozzle. • Plasticized material discharging from the nozzle.
<p>Plasticizing and / or Injection Unit Area Area from the adapter / barrel head / end cap to the extruder motor above the sled including the carriage cylinders. See Figure 3-1 area 5</p>	<p>Mechanical Hazards Crushing, shearing and / or drawn-into hazards caused by:</p> <ul style="list-style-type: none"> • Unintentional gravity movements e.g. for machines with plasticizing and / or injection unit positioned above the mold area. • The movements of the screw and / or the injection plunger in the cylinder accessible through the feed opening. • Movement of the carriage unit. <p>Thermal Hazards Burns and or scalds due to operating temperature of:</p> <ul style="list-style-type: none"> • The plasticizing and / or injection unit. • The heating elements e.g. heater bands. • The plasticized material and / or vapors discharging from the vent opening, feed throat or hopper. <p>Mechanical and / or Thermal Hazard Hazards due to reduction in mechanical strength of the plasticizing and / or injection cylinder due to overheating.</p>
<p>Feed Opening See Figure 3-1 area 6</p>	<p>Pinching and crushing between injection screw movement and housing.</p>

Safety Hazards - continued

Table 3-1 Safety Hazards	
Hazard Area	Potential Hazards
Area of the Heater Bands of the Plasticizing and / or Injection Cylinders See Figure 3-1 area 7	Burns and / or scalds due to operating temperature of: <ul style="list-style-type: none"> • The plasticizing and / or injection unit. • The heating elements e.g. heater bands. • The plasticized material and / or vapors discharging from the vent opening, feed throat or hopper.
Parts Discharge Area See Figure 3-1 area 8	Mechanical Hazards Accessible through the discharge area Crushing, shearing and / or impact hazards caused by: <ul style="list-style-type: none"> • Closing movement of the platen. • Movements of cores and ejectors and their drive mechanisms. Thermal Hazards Accessible through the discharge area Burns and or scalds due to operating temperature of: <ul style="list-style-type: none"> • The mold. • Heating elements of the mold. • Plasticized material released from / through the mold.
Hoses See Figure 3-1 area 9	<ul style="list-style-type: none"> • Whipping action caused by hose assembly failure. • Possible release of fluid under pressure that can cause injury. • Thermal hazards associated with hot fluid.
Area Inside the Guards and Outside the Mold Area See Figure 3-1 area 10	Crushing and / or shearing and / or impact hazards caused by: <ul style="list-style-type: none"> • Movement of the platen. • Movement of the drive mechanism of the platen. • Movement of the core and ejector drive mechanism. • Clamp opening movement.
Electrical Hazards	<ul style="list-style-type: none"> • Electrical or electromagnetic disturbance generated by the motor control unit. • Electrical or electromagnetic disturbance that can cause failures in the machine control systems and adjacent machine controls. • Electrical or electromagnetic disturbance generated by the motor control unit.
Hydraulic Accumulators	High pressure discharge.
Power Operated Gate	Crush or impact hazards caused by the movement of the power operated gates.
Vapors and Gases	Certain processing conditions and / or resins can cause hazardous fumes or vapors.



3.2 Operational Hazards

WARNINGS

- Refer to all machine manuals and local regulations and codes for safety information.
- The equipment supplied is subjected to high injection pressures and high temperatures. Ensure that extreme caution is observed in the operation and maintenance of the injection molding machines.
- Only fully trained personnel should operate or maintain equipment.
- Do not operate the equipment with unconfined long hair, loose clothing or jewelry, including name badges, neckties, etc. These may get caught in the equipment and can cause death or serious injury.
- Never disable or bypass a safety device.
- Ensure that the protective guards are placed around the nozzle to prevent the material from splashing or drooling.
- A burn hazard exists from material during routine purging. Wear heat-resistant personal protective equipment (PPE) to prevent burns from contact with hot surfaces or splatter of hot material and gases.
- Material purged from machine may be extremely hot. Ensure protective guards are in place around the nozzle to prevent material from splashing. Use proper personal protective equipment.
- All operators should wear personal protective equipment, such as face shields and use heat resistant gloves when working around the feed inlet, purging the machine or cleaning the gates of the mold.
- Remove purged material from the machine immediately.
- Decomposing or burning material could result in noxious gases being emitted from the purged material, feed inlet or mold.
- Ensure proper ventilation and exhaust systems are in place to help prevent inhalation of harmful gases and vapors.
- Consult manufacturer's Material Safety Data Sheets (MSDS).
- Hoses fitted to the mold will contain high or low temperature fluids or air under high pressure. The operator must shut down and lockout these systems as well as relieving any pressure before performing any work with these hoses. Regularly inspect and replace all flexible hoses and restraints.
- Water and / or hydraulics on the mold may be in close proximity to electrical connections and equipment. Water leakage may cause an electrical short circuit. Hydraulic fluid leakage may cause a fire hazard. Always keep water and / or hydraulic hoses and fittings in good condition to avoid leaks.
- Never perform any work on the mold machine unless the hydraulic pump has been stopped.
- Check frequently for possible oil leaks / water leaks. Stop the machine and make repairs.



Operational Hazards - continued**WARNING**

- Make sure that the cables are connected to the correct motors. Cables and motors are clearly labeled. Reversing the cables can result in unexpected and uncontrolled motion causing a safety risk or damage to the machine.
- A crushing hazard exists between the nozzle and mold melt inlet during carriage forward motion.
- A possible shearing hazard exists between the edge of the injection guard and the injection housing during injection.
- The open feed port could present a hazard to a finger or a hand inserted during operation of the machine.
- The electric servo motors could overheat presenting a hot surface which could cause burns to someone touching it.
- The barrel, barrel head, nozzle, heater bands and mold components are hot surfaces which could result in burns.
- Keep flammable liquids or dust away from the hot surfaces as they could ignite.
- Follow good housekeeping procedures and keep floors clean to prevent slips, trips and falls due to spilled material on the work floor.
- Apply engineering controls or hearing conservation programs as necessary to control noise.
- When doing any work on the machine that requires moving and lifting the machine, ensure that lifting equipment (eyebolts, fork lift truck, cranes, etc.) will have sufficient capacity to handle mold, auxiliary injection unit or Hot Runner weight.
- Connect all lifting devices and support the machine using a crane of adequate capacity before commencing work. Failure to support the machine can result in severe injury or death.
- Mold cable from the controller to the mold must be removed before servicing the mold.

3.3 General Safety Symbols

Table 3-2 Typical Safety Symbols	
Symbol	General Description
	General – Warning Indicates an immediate or potentially hazardous situation, which if not avoided, could result in a serious injury or death, and / or damage to equipment.
	Warning – Barrel Cover Grounding Strap Lockout / tagout procedures must be followed before removing the barrel cover. Barrel cover can become energized upon removal of grounding straps and contact can result in death or serious injury. Grounding straps must be reconnected before reconnecting power to machine.
	Warning – Crushing and / or Impact Points Contact with moving parts can cause serious crushing injury. Always keep guards in place.
	Warning – Crush Hazard Closing Mold
	Warning – Hazardous Voltage Contact with hazardous voltages will cause death or serious injury. Turn off power and review electrical schematics before servicing equipment. May contain more than one live circuit. Test all circuits before handling to make sure circuits have been de-energized.
	Warning – High Pressure Overheated fluids may cause severe burns. Discharge pressure before disconnecting water lines.
	Warning – High Pressure Accumulator Sudden release of high pressure gas or oil can cause death or serious injury. Discharge all gas and hydraulic pressure before disconnecting or disassembling accumulator.
	Warning – Hot Surfaces Contact with exposed hot surfaces will cause serious burn injury. Wear protective gloves when working near these areas.
	Mandatory – Lockout / Tagout Ensure that all energies are properly locked out, and remain locked out until the service work is completed. Servicing equipment without disabling all internal and external power sources can cause death or serious injury. De-energize all internal and external power sources (electrical, hydraulic, pneumatic, kinetic, potential, and thermal).
	Warning – Material Splashing Hazard Material or high pressure gas can cause death or severe burns. Wear personal protective equipment while servicing the feed throat, nozzle, mold areas and when purging the injection unit.
	Warning – Read Manual Before Operation Personnel should read and understand all instructions in the manuals before working on equipment. Only properly trained personnel should operate the equipment.
	Warning – Slip, Trip or Fall Hazard Do not climb on equipment surfaces. Serious slip, trip or fall injuries can result from personnel climbing on equipment surfaces.

General Safety Symbols - continued

Table 3-2 Typical Safety Symbols	
Symbol	General Description
	Caution Failure to follow instructions may damage equipment.
	Important Indicates additional information or used as a reminder.

3.4 Wiring Check



CAUTION

System Mains Supply Wiring:

- Before connecting the system to a power supply, it is important to check that the wiring between the system and the power supply has been done correctly.
- Particular attention must be given to the current rating of the power supply. For example, if a controller is rated at 63A, then the power supply must also be rated at 63A.
- Check that the phases of power supply are wired correctly.

Controller to Mold Wiring:

- For separate power and thermocouple connections, ensure that the power cables are never connected to the thermocouple connectors and vice-versa.
- For mixed power and thermocouple connections, ensure that the power and thermocouple connections have not been wired incorrectly.

Communications Interface and Control Sequence:

- It is the customer's responsibility to verify functionality of any custom machine interface at safe speeds, prior to operating equipment in the production environment at full speed in automatic mode.
- It is the customer's responsibility to verify all required motion sequences are correct, prior to operating equipment in the production environment at full speed in automatic mode.
- Switching the machinery into Auto mode without having verified the control interlocks and motion sequence are correct, may cause damage to machinery and / or equipment.

Failure to do wiring or connections properly will result in equipment failure.

3.5 Lockout Safety



WARNING

DO NOT enter the cabinet without first ISOLATING the supplies.

High voltage and amperage cables are connected to the controller and the mold. Electrical power must be shut off and lockout / tagout procedures followed prior to installing or removing any cables.

Use lockout / tagout to prevent operation during maintenance.

All maintenance should be performed by properly trained personnel based on local laws and regulation. Electrical products may not be grounded when removed from the assembled or normal operating condition.

Ensure proper grounding of all electrical components before performing any maintenance to avoid potential risk of electrical shock.

Often power sources are inadvertently turned on or valves are opened mistakenly before maintenance work is completed, resulting in serious injuries and fatalities. Therefore, it is important to ensure that all energies are properly locked out and that they remain locked out until the work is completed.

If a lockout is not performed, uncontrolled energies could cause:

- Electrocution from contact with live circuits
- Cuts, bruises, crushing, amputations or death, resulting from entanglement with belts, chains, conveyors, rollers, shafts, impellers
- Burns from contact with hot parts, materials or equipment such as furnaces
- Fires and explosions
- Chemical exposures from gases or liquids released from pipelines



3.5.1 Electrical Lockout

WARNING - READ MANUAL

Refer to all machine manuals and local regulations and codes.

NOTE

In some instances, there may be more than one power source feeding equipment and steps must be taken to ensure that all sources are effectively locked out.

Employers must provide an effective lockout / tagout program.

1. Shut down machine using normal operational shutdown procedure and controls. This should be done by, or in consultation with the machine operator.
2. After ensuring that the machinery has been completely shut down, and all controls in the “off” position, open the main disconnect switch located in the field.
3. Using your own personal padlock, or one assigned by your supervisor, lock the disconnect switch in the off position. Do not lock only the box. Remove the key and retain. Complete a lockout tag and affix to the disconnect switch. Each person working on the equipment must follow this step. The lock of the person doing the work or in charge must be installed first, remain throughout and be removed last. Test the main disconnect switch and make sure it cannot be moved to the “on” position.
4. Try to start the machine using the normal operation controls and point of operation switches to make sure that the power has been disconnected.
5. Other sources of energy that could create a hazard while working on the equipment must also be de-energized and appropriately “locked-out”. This can include gravity, compressed air, hydraulics, steam and other pressurized or hazardous liquids and gases. See Table 3-3.
6. When the work is completed, prior to removing the last lock, make sure the operational controls are in the “off” position so that the main disconnect switching is done under “no load”. Ensure all blocks, tools and other foreign materials are removed from machine. Also ensure that all personnel that may be affected are informed that the lock(s) will be removed.
7. Remove lock and tag, and close the main disconnect switch if permission has been given.
8. When the work has not been completed on the first shift, the next operator should install a personal lock and tag before the first operator removes the original lock and tag. If the next operator is delayed, a lock and tag could be installed by the next supervisor. Lockout procedures should indicate how the transfer is to be conducted.
9. It is important that, for their personal protection, each worker and/or fore person working in or on a machine places his/her own safety lock on the disconnect switch. Use tags to spotlight work in progress and give details of work being done. Only when the work is completed and the work permit signed off, may each worker remove his/her lock. The last lock to be removed should be that of the person supervising the lockout and this responsibility should not be delegated.

© Industrial Accident Prevention Association, 2008.

3.5.2 Energy Forms and Lockout Guidelines

Table 3-3 Energy Forms, Energy Sources and General Lockout Guidelines		
Energy Form	Energy Source	Lockout Guidelines
Electrical Energy	<ul style="list-style-type: none"> • Power transmission lines • Machine power cords • Motors • Solenoids • Capacitors (stored electrical energy) 	<ul style="list-style-type: none"> • Turn off power at machine first (i.e., at point of operation switch), and then at the main disconnect switch for the machine. • Lock and tag the main disconnect switch. • Fully discharge all capacitive systems (e.g., cycle machine to drain power from capacitors) according to the manufacturer's instructions.
Hydraulic Energy	<ul style="list-style-type: none"> • Hydraulic systems (e.g., hydraulic presses, rams, cylinders, hammers) 	<ul style="list-style-type: none"> • Shut off, lock (with chains, built-in lockout devices, or lockout attachments) and tag valves. • Bleed off and blank lines as necessary.
Pneumatic Energy	<ul style="list-style-type: none"> • Pneumatic systems (e.g., lines, pressure reservoirs, accumulators, air surge tanks, rams, cylinders) 	<ul style="list-style-type: none"> • Shut off, lock (with chains, built-in lockout devices, or lockout attachments) and tag valves. • Bleed off excess air. • If pressure cannot be relieved, block any possible movement of machinery.
Kinetic Energy (Energy of a moving object or materials. Moving object may be powered or coasting)	<ul style="list-style-type: none"> • Blades • Flywheels • Materials in supply lines 	<ul style="list-style-type: none"> • Stop and block machine parts (e.g. stop flywheels and ensure that they do not recycle). Review entire cycle of mechanical motion and ensure that all motions are stopped. • Block material from moving into area of work. • Blank as required.
Potential Energy (Stored energy that an object has the potential to release due to its position)	<ul style="list-style-type: none"> • Springs (e.g., in air brake cylinders) • Actuators • Counterweights • Raised loads • Top or movable part of a press or lifting device 	<ul style="list-style-type: none"> • If possible, lower all suspended parts and loads to the lowest (rest) position. • Block parts that might be moved by gravity. • Release or block spring energy.
Thermal Energy	<ul style="list-style-type: none"> • Supply lines • Storage tanks and vessels 	<ul style="list-style-type: none"> • Shut off, lock (with chains, built-in lockout devices, or lockout attachments) and tag valves. • Bleed off excess liquids or gases. • Blank lines as necessary.

3.6 Disposal



WARNING

Milacron Mold-Masters declines any responsibility for personal injury or personal damage arising from reuse of the individual components, if these parts are used other than for the original and proper intended purpose.

1. Hot Runner and system components must be disconnected from the power supply fully and properly before disposal, including electricity, hydraulics, pneumatics and cooling.
2. Ensure that the system to be disposed of is free from fluids. In the case of hydraulic needle valve systems, drain the oil from the lines and cylinders and dispose it in an environmentally responsible manner.
3. The electrical components are to be dismantled, separating them accordingly as environmentally friendly waste or disposed as hazardous waste if necessary.
4. Remove the wiring. The electronic components are to be disposed in accordance with the national electric scrap ordinance.
5. The metal parts are to be returned for metal recycling (waste metal and scrap trade). The instructions of the corresponding waste disposal company are to be observed in this case.

Recycling of the materials occupies a forefront position during the disposal process.

3.7 Dura Plus Safety Hazards



WARNING

- The equipment supplied is subjected to high injection pressures and high temperatures.
- Ensure that extreme caution is observed in the operation and maintenance of the Hot Runner system and the injection molding machines.
- Do not operate the equipment with unconfined long hair, loose clothing or jewelry, including name badges, neckties, etc. These may get caught by the moving belt mechanism and can cause death or serious injury.
- Never disable or bypass a safety device.
- All operators should wear personal protective equipment, such as face shields and use heat resistant gloves when working around the feed inlet, purging the machine or cleaning the gates of the mold.
- Check frequently for possible oil or water leaks. Stop the machine and make repairs.
- Do not look directly into the feed throat of a hopper. Unexpected release of resin may cause serious burns. Use a mirror. Failure to do so may cause serious injury.
- Remove purgings from the machine immediately. Never directly handle plastic purgings or drool until they have completely cooled. Purgings may appear solid but may still be hot and cause serious injury.
- The equipment supplied is subjected to high injection pressures and high temperatures.
- Ensure that extreme caution is observed in the operation and maintenance of the Hot Runner system and the injection molding machines.
- Do not operate the equipment with unconfined long hair, loose clothing or jewelry, including name badges, neckties, etc. These may get caught by the moving belt mechanism and can cause death or serious injury.
- Never disable or bypass a safety device.
- Check frequently for possible oil or water leaks. Stop the machine and make repairs.
- Do not look directly into the feed throat of a hopper. Unexpected release of resin may cause serious burns. Use a mirror. Failure to do so may cause serious injury.
- Some plastics develop gases that may be dangerous to personal health.
- Follow the plastics supplier's recommendations. Review their material safety data sheet. Ensure the molding area is well ventilated.
- Never touch or inspect the timing belt when power is on and motor and controller are connected. Unplug the controller before any maintenance.
- Always cover E-Drive belt area / molding machine drop out area / bench top with a proper protective cover before any bench test or in-mold testing.
- Always unplug the controller before performing any maintenance work.

Dura Plus Safety Hazards - continued**WARNING**

- Voltage and amperage cables are connected to the controller and the mold. Electric power must be shut off and lockout / tagout procedures followed prior to installing or removing any cables.
- Hoses fitted to the mold will contain high or low temperature fluids or air under high pressure. The operator must shut down and lockout these systems as well as relieving any pressure before performing any work with these hoses.
- Never perform any work on the mold unless the hydraulic pump has been stopped.
- High voltage and amperage cables are connected to the mold. Electric power must be shut off prior to installing or removing any cables.
- Water and / or hydraulics on the mold may be in close proximity to electrical connections and equipment. Water leakage may cause an electrical short circuit. Hydraulic fluid leakage may cause a fire hazard. Always keep water and/or hydraulic hoses and fittings in good condition to avoid leaks.
- Make sure the lifting eyebolt, lifting chain and crane are rated to adequately support the weight of the plate(s). Failure to do so can cause a serious injury.
- All maintenance on Mold-Masters products should be performed by properly trained personnel based on local law or regulation requirements.
- Ensure proper grounding of all electrical products before performing any maintenance to avoid potential risk of electrical shock.
- Make sure the machine has been locked out and tagged out in accordance to the machine's documented procedures. Failure to do so may lead to serious injury or death.
- Check that all coolant, hydraulic and air lines as well as electrical cables will not interfere with the moving parts of the mold, machine or robot. The lines must be of sufficient length so that they will not strain or pinch when the mold halves separate.
- For water cooling nozzle jacket, coolant must be maintained with the proper mixture to prevent corrosion and circuit blockage. Care must be taken to ensure the nozzle terminal ends do not come in contact with the hydraulic fluid. The nozzles may short out or become damaged.
- Do not mix electrical power cables with thermocouple extension cables. They are not designed to carry the power load or list accurate temperature readings in each other's application.

Dura Plus Safety Hazards - continued**CAUTION**

All Mold-Masters heated components are manufactured to standards that ensure safe and reliable operation provided that the following precautions are met:

- To maximize heater element and component life, the temperature must be controlled and maintained within safe operating limits. Mold-Masters strongly recommends individual control of each heated component, including heater plates, with a reliable temperature controller that includes soft-start protection.
- Always operate the system using correctly installed “J” type thermocouples connected to a reliable temperature controller with soft-start protection.
- Avoid running the system for long periods on manual control.
- Use caution when applying power in manual mode. Use minimum heat required for the process to avoid overheating and possible damage to components.
- Always replace pinched or damaged thermocouples.
- When grouping heated components together and controlling more than one load from a single thermocouple, make sure that the components are of similar material, wattage, size and are exposed to the same thermal conditions.
- When replacing heater plates or other heated components always replace with Mold-Masters components of the same type and install as originally specified on Mold-Masters General Assembly drawings.

Section 4 - Preparation



WARNING

Ensure that you have fully read “Section 3 - Safety” before unpacking, cleaning or assembling parts of the Dura Plus Hot Runner system.

The following section is a step-by-step guide to prepare your Mold-Masters system for use.

4.1 Tools Required

Depending on the size and complexity of your Hot Runner system, you will require most of the tools and materials listed below:

- Allen keys: depending on system, set of metric or imperial size keys for use on cap screws (4, 5, 6, 8 and 10 mm or imperial equivalent)
- Nickel based anti-seize compound: to prevent oxidation of screw threads that could cause screws to seize with high temperatures
- Solvents (denatured alcohol): for removal of rust inhibitors
- Calibrated torque wrench: for consistent screw pressure throughout the system
- Pliers: for general assembly work
- Circlip pliers: to remove and install circlip in valve systems
- Micrometer: (sizes 0-6” and 0-150 mm) to check system part and plate thickness
- Depth micrometer: to check bore depths
- Slot head screw driver: used in installing thermocouples and ground wires
- Slot head screw driver (small): used in fastening electrical wires to connectors
- Crimping tool: for fastening connector pins when necessary
- Wire strippers: for preparing wires
- Utility knife: for cutting tape, wires etc.
- Glass tape: for grouping wires into zones
- Die-spotting blue compound: for checking face contact
- Sockets
- Lapping compound for valve gate systems
- Plastic face hammer
- Proper actuator installation / extraction tools
- Retaining ring pliers for bore diameter bigger than 65 mm
- Removal tool for crimp contacts when necessary



Figure 4-1 Toolkit required

4.2 Screw Lengths



WARNING

Be aware of warnings placed on the General Assembly drawing. When the manifold is heated the metal expands, stretching the mounting screws. If screw lengths are shortened there is a possibility of shearing.

The expansion factor is calculated into the length of each screw size.



CAUTION

The use of an incorrect size, length and grade screw could cause the screw to shear, fatigue or stretch beyond its yield point, resulting in expensive downtime of the Hot Runner.

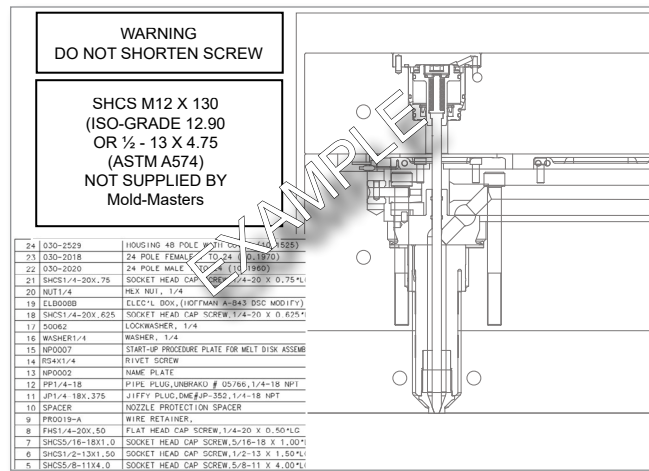

Figure 4-2 Screw Length

4.3 Unpacking



WARNING

Make sure the lifting eyebolt, lifting chain and crane are rated to adequately support the weight. Failure to do so can cause a serious injury.

Make sure the machine has been locked out and tagged out in accordance to the machines documented procedures. Failure to do so may lead to serious injury or death.

1. Carefully open the shipping crate and inspect contents. Secure loose items and check that the system is received in good condition and no damage occurred during shipment. Remove any documentation or spares packages and set aside.
2. After removing all restraints, attach the crane to the hoist and carefully remove the system from the shipping crate.
3. Check that all mold base dimensions are correct and correspond to Mold-Masters General Assembly drawing.

4.4 Cleaning

All nozzles, manifolds and Hot Runner components must be free of the rust inhibitor applied at the factory.

1. Remove protective covers from all gate seals.
2. Clean all surfaces and dowel holes, ensuring that no debris, burrs, shavings, dust, dirt or other foreign material which could interfere with measurements, exists. Ream holes out if necessary.
3. Remove tape from inlet and clean.

Section 5 - Assembly



WARNING

Ensure that you have fully read “Section 3 - Safety” before assembling parts of the Dura Plus Hot Runner system.

Some Dura Plus systems are designed in modules for easy installation, quick startups and user friendly maintenance. Some systems may be supplied with certain additional components for “Plug & Play” function. Please refer to your General Assembly drawing for details on the system ordered.

The following assembly instructions are largely for reference purposes. The wiring and plumbing instructions at the end of the section will be helpful for assembling the system.

See “Section 9 - Installation” for instructions on installing your Dura Plus Hot Runner into an existing manifold plate system or spacer block system.

Optional Components / Features:

- Optional water cooling nozzle jacket

5.1 Typical Dura Plus System

An example Dura Plus system is provided below to illustrate the various components.

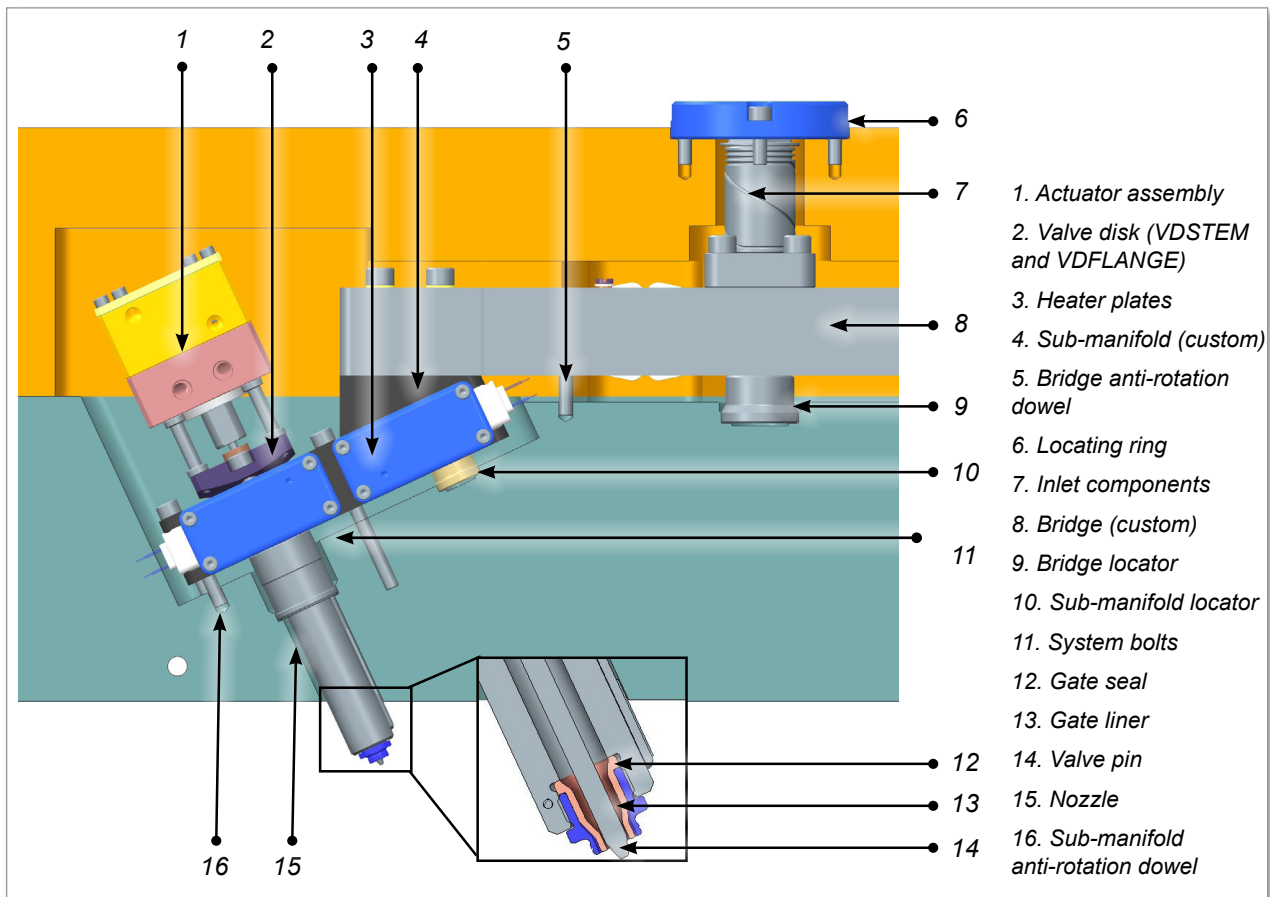

Figure 5-1 Typical Dura Plus system

5.2 Pre-Assembly Checks of Gate Seals and Nozzle



CAUTION

Gate seals are torqued at ambient (room) temperature at Mold-Masters. Please torque each seal at processing temperature to the torque value specified to prevent material leakage from the gate seal.

1. Apply die-spotting blue compound to the gate seal (and liner, if used) to ensure a proper contact on sealing surface.

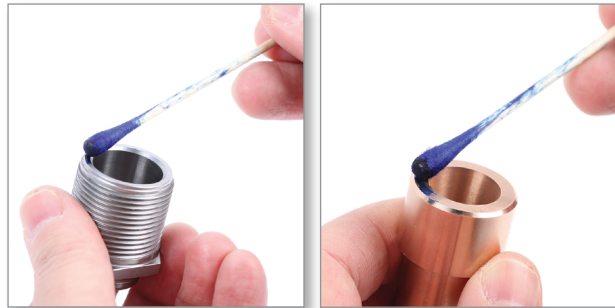

2. Torque the gate seal to specified value. Refer to the General Assembly drawing for torque values.



3. Remove the gate seal and verify transfer of die-spotting blue compound from gate to the liner and to nozzle. If not 100% blue on the face, contact your Mold-Masters representative.



4. Clean die-spotting blue compound from components.

5.3 Assembly of Gate Seals to Nozzle

1. Apply anti-seize compound to all threaded interfaces.



2. Ensure all sealing surfaces are clean and dry.
3. Install gate seal and liner.



4. Torque to specified values. Refer to the General Assembly drawing for torque values.



5. Heat nozzle to processing temperature and re-torque seal.

5.4 Thermocouple Installation for 01 Nozzle



CAUTION

Ensure the terminal end of the thermocouple stays fully engaged in the slot while bending the thermocouple at the nozzle flange area.

1. Clean the thermocouple bore in the nozzle. For 2 mm thermocouples we suggest using a 2.1 mm drill in a pin vise.



2. Insert the thermocouple through the flange bore.



3. Manually bend the thermocouple tip against your thumb to approximately a 90° angle, ensuring bend length is sufficient to reach the bottom of the thermocouple bore.



4. Press thermocouple carefully alongside nozzle body and install retaining clip(s). Check parts list for recommended number of clips for the nozzle type. Check that the thermocouple fits into the recess of the clip.

Thermocouple Installation for 01 Nozzle - continued**IMPORTANT**

One retainer clip must be at the top of the nozzle to keep the thermocouple inside the bore. This is especially important when thermocouples are assembled from the front.



5. Install the terminal end retaining clip. Check that the thermocouple is seated in the recess of the terminal end clip.

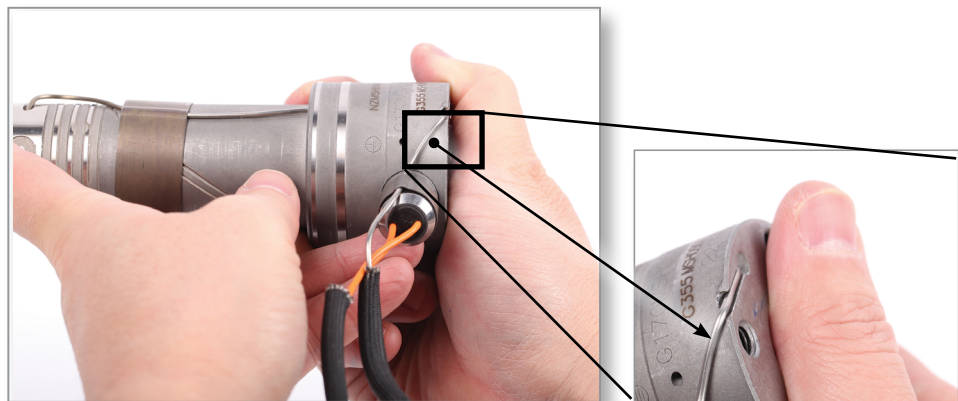

6. Use heat resistant tape to secure the nozzle wires and thermocouple wires just above or below the insulator pod.

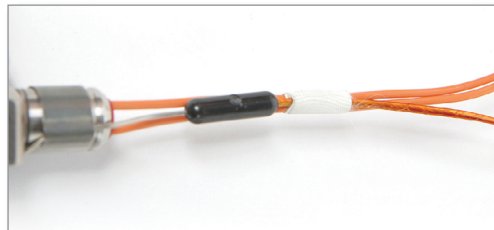

5.4.1 02 Nozzle Flange Assembly



CAUTION

Nozzles should be torqued at ambient (room) temperature and then re-torqued at processing temperature to the torque value specified to prevent material leakage.

1. Apply anti-seize compound to the ball plunger threads.

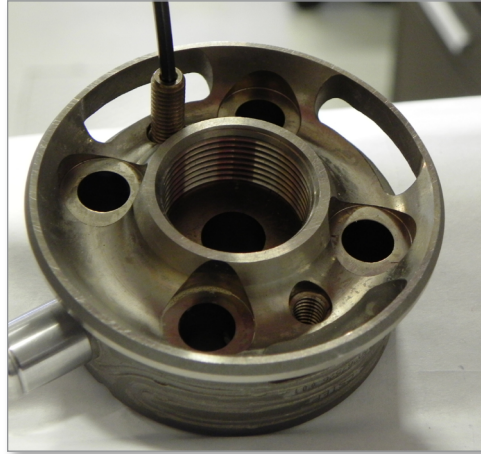

2. Install the ball plunger into the flange with a 2.5 mm (0.10 in.) hex wrench. Make sure the ball plunger top surface is lower than the flange top surface by at least 0.08 mm (0.003 in.).

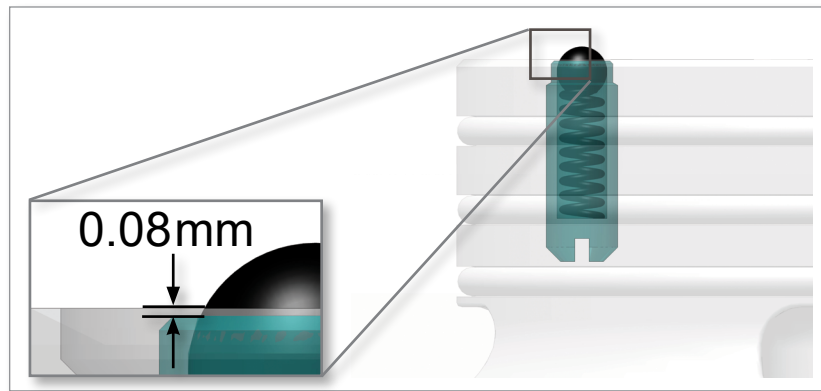

3. Apply die-spotting blue compound to the thread to ensure a proper contact with the flange.

02 Nozzle Flange Assembly - continued

4. Apply anti-seize compound to the nozzle threads and then thread the nozzle into the flange. Torque nozzles to the following values:

For Hecto Nozzles: torque value is 135Nm (100 ft lb)

For Mega Nozzles: torque value is 183Nm (135 ft lb)

Remember to re-torque at process temperature when system assembly is complete.



5. Insert five spring clips (SPRG15) into the M6 shoulder bolt (SHSSM6X25), and apply anti-seize compound to the thread.



02 Nozzle Flange Assembly - continued

6. Locate the nozzle assembly to the manifold by lining up the two ball plungers to the dimples on manifold bottom surface. Make sure the balls sit completely inside the dimple.

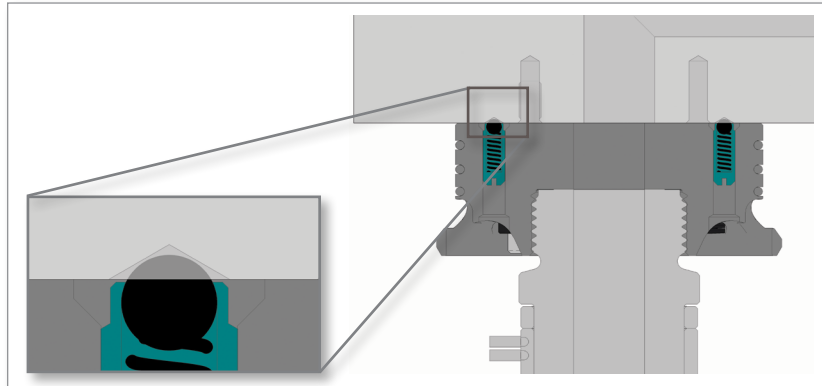

7. Torque the two M5 shoulder bolts to 9.5 Nm (84 lbf.in.).

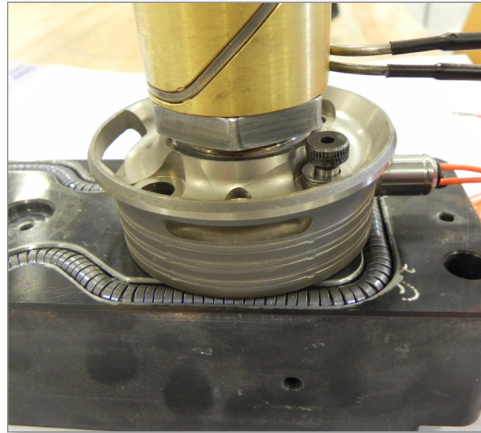

5.5 Sub-Manifold Assembly for Drop-In System

5.5.1 Install Valve Disk (Valve Disk Design)

1. Apply die-spotting blue compound to the valve disk stem.

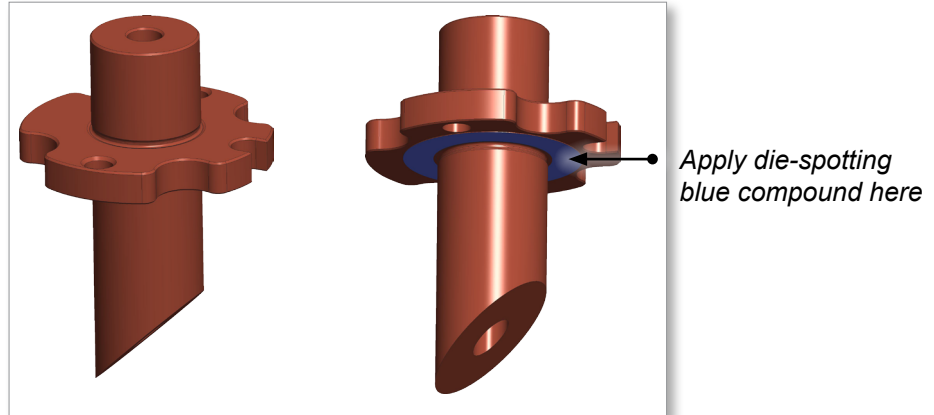

2. Line up the valve disk stem into the manifold hole.

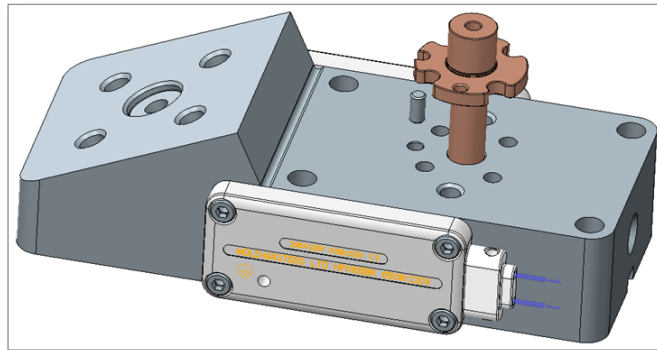

3. Install the valve disk flange on top of the valve disk stem.

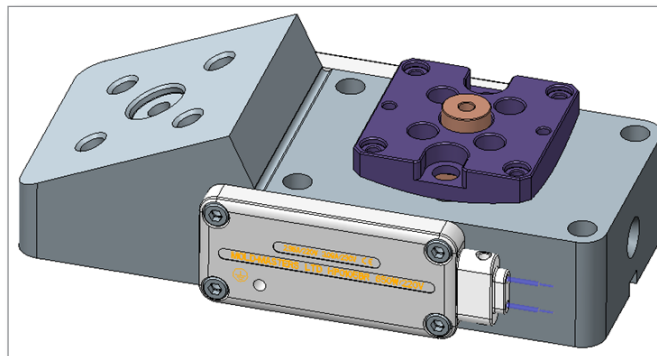

4. Install the screws and torque. Refer to the General Assembly drawing for torque values.

Install Valve Disk (Valve Disk Design) - continued

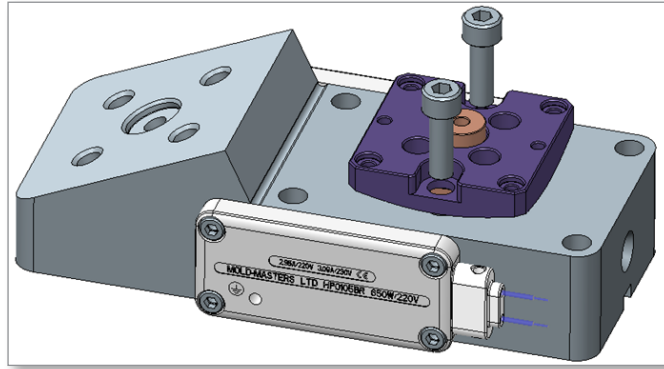

5. Remove the valve disk stem and verify that the die-spotting blue compound is continuous on the valve disk stem or manifold contact surfaces.

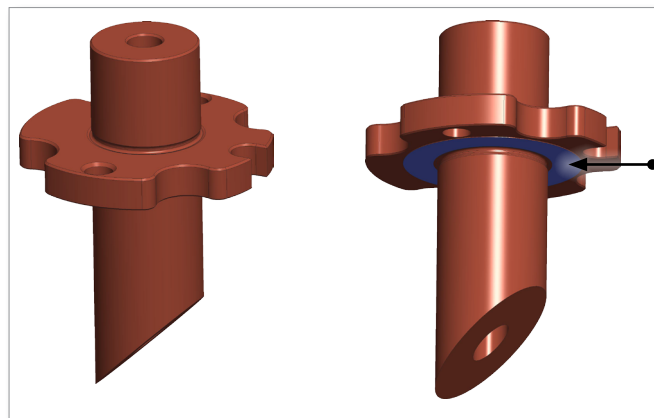

6. Clean the die-spotting blue compound from all components.
7. Apply anti-seize compound to screws, reinstall the valve disk stem and valve disk flange and torque in a crossing pattern. Refer to the General Assembly drawing for torque values.

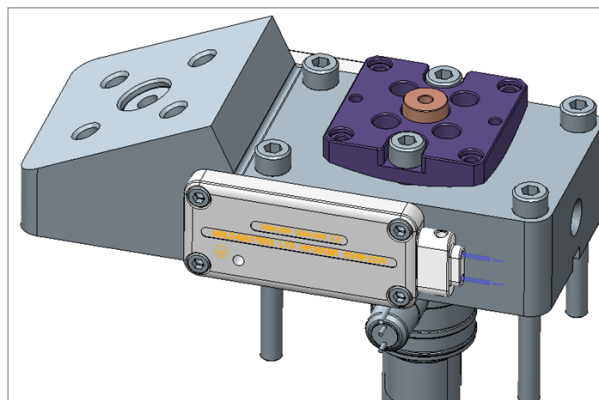

8. Install the valve pin to verify fit.

Install Valve Disk (Valve Disk Design) - continued

9. Install screws in a crossing pattern to nozzle through the manifold.

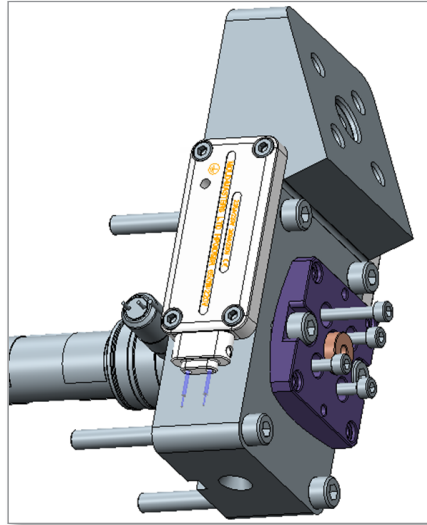

NOTE

Ensure nozzle terminal end is in the direction noted on the General Assembly drawing.



5.5.2 Install Valve Disk with Nozzle and Heater Sleeves

1. Place sub-manifold on nozzle with heater sleeves, install the screws and torque to the specified value. Refer to the General Assembly drawing for torque values.



NOTE

Heater plates are not shown in pictures below for clarity.

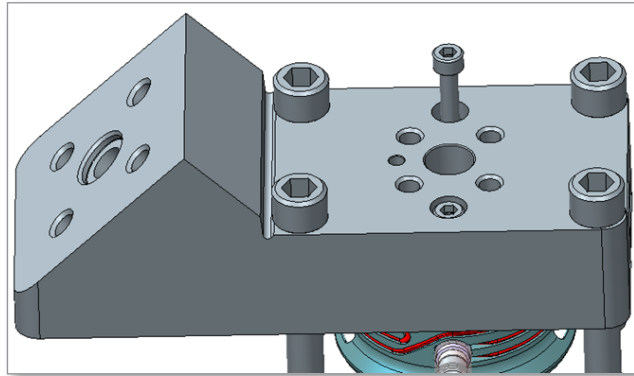

2. Install dowel pin.

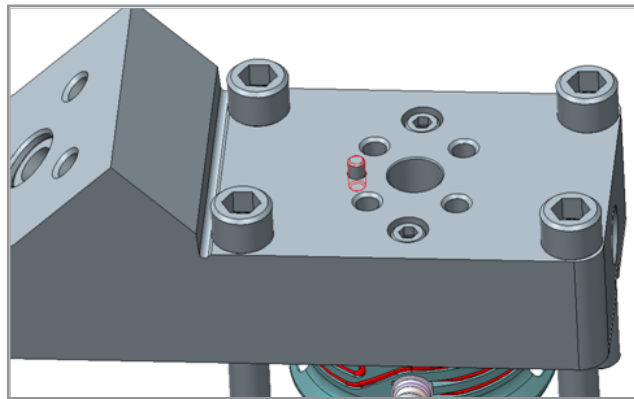

3. Apply die-spotting blue compound to the valve disk stem.

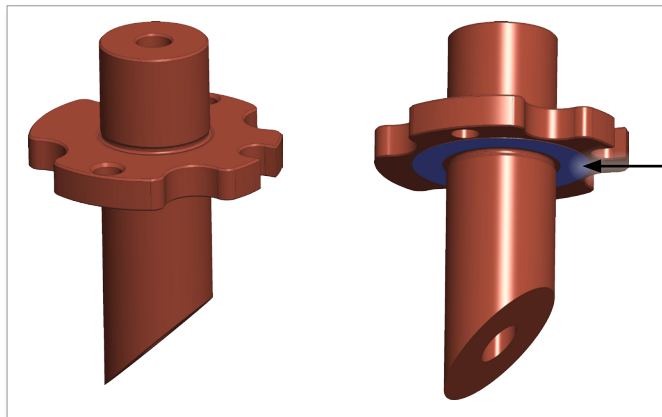

4. Line up the valve disk stem into the manifold hole. Install and confirm

Install Valve Disk with Nozzle with Heater Sleeves - continued

sealing contact.

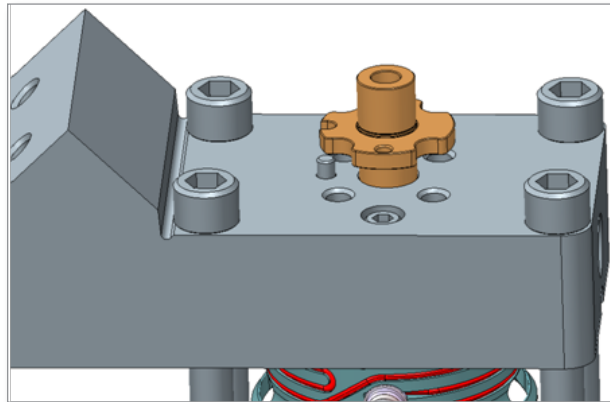

5. Install valve disk flange on top of valve disk stem.

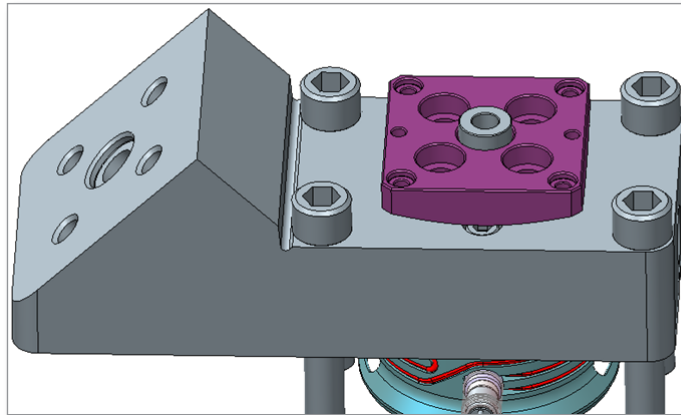

6. Install the screws and torque to the specific value. Refer to the General Assembly drawing for torque values.

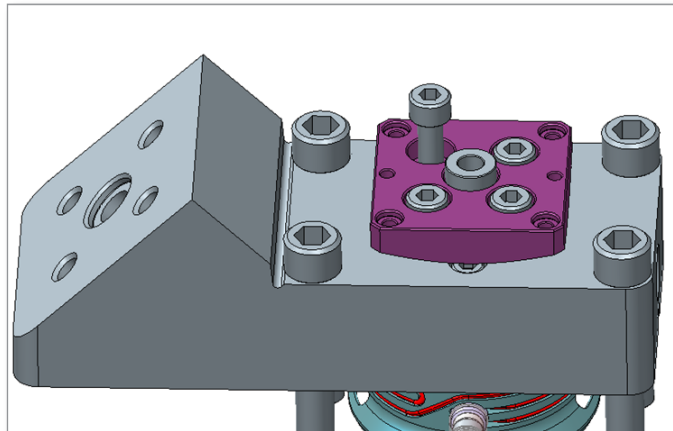

7. Remove the valve disk stem and verify die-spotting blue compound is continuous on valve disk stem / manifold contact surfaces.

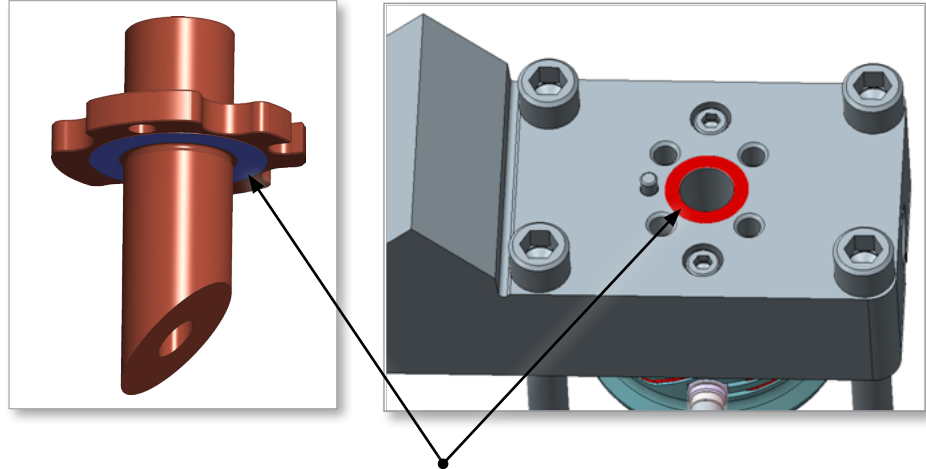

Verify the continuity of the die-spotting blue compound

8. Clean die-spotting blue compound from all components.
9. Apply anti-seize compound to the screws and reinstall the valve disk stem and valve disk flange, torquing in a crossing pattern to the specified value. Refer to the General Assembly drawing for torque values.

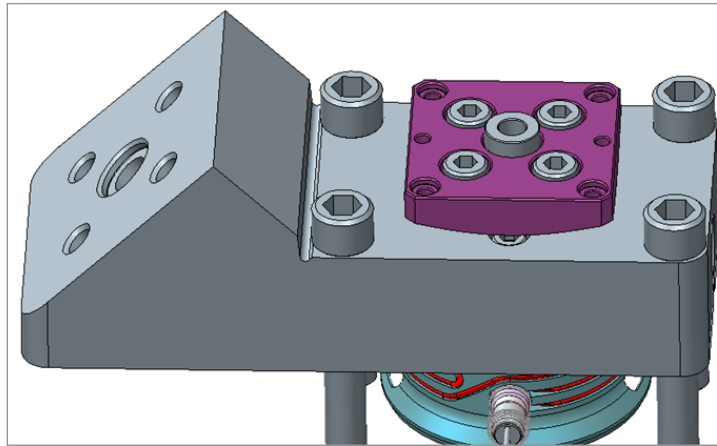

5.5.3 Hydraulic System Installation

1. Install the spacers on top of the manifold or valve disk flange.

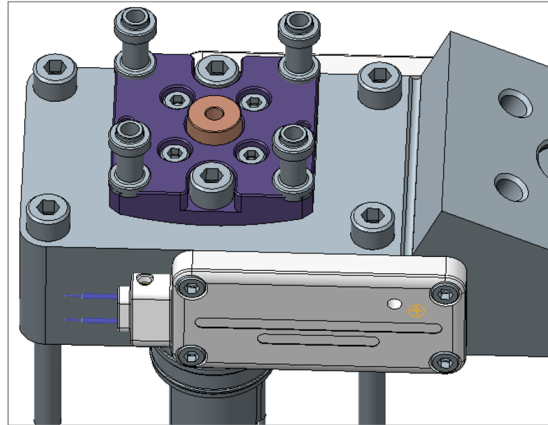

2. Locate actuator on top of the spacers. Make sure to align the fitting ports in the appropriate direction.

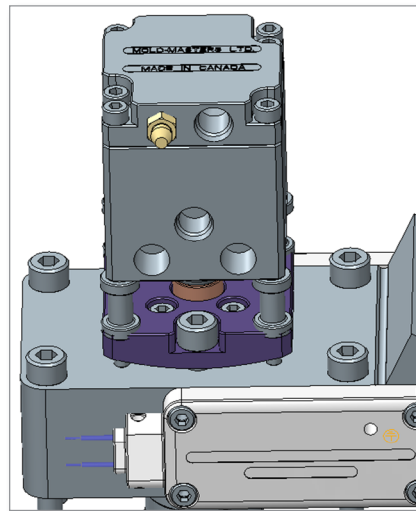

3. Apply anti-seize compound to the screws.

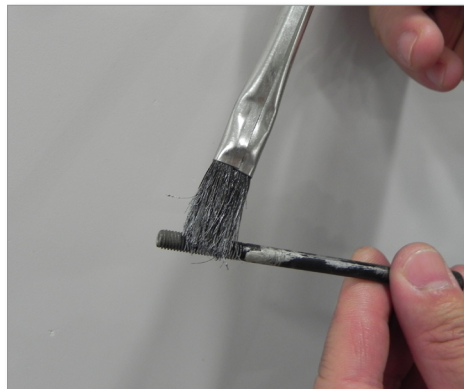

4. Torque screws in a crossing pattern, gradually increasing torque to the specified value. Refer to the General Assembly drawing for torque values.

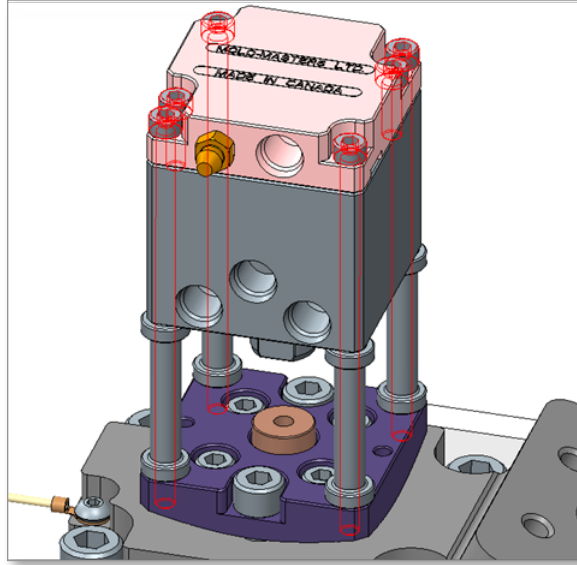

5.6 Actuator Assembly

5.6.1 Install Pneumatic Actuator Assembly

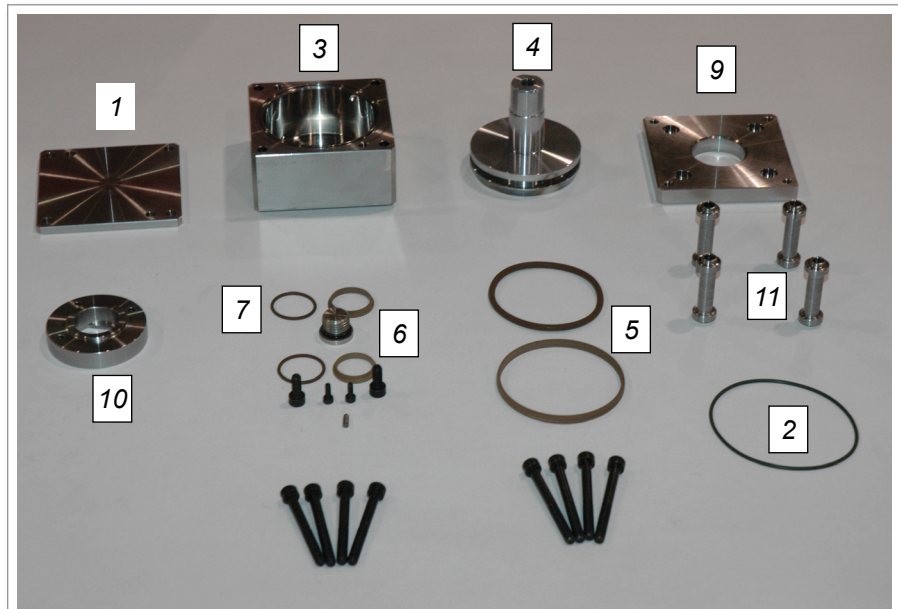

Pneumatic cylinder components

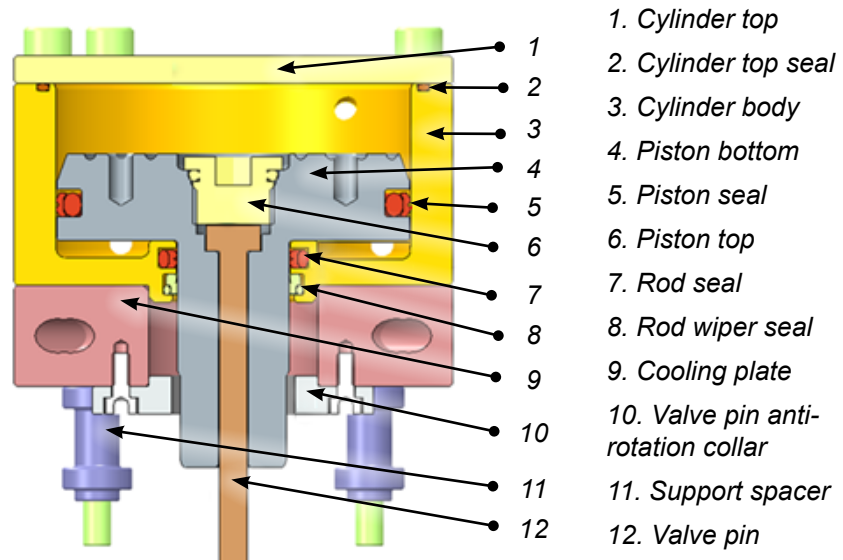

Pneumatic cylinder section view

Figure 5-2 Pneumatic cylinder components



NOTE

Pneumatic actuators with spring packages are available for certain sizes. See General Assembly drawing for details.

1. Install the rod seal (2 pieces).

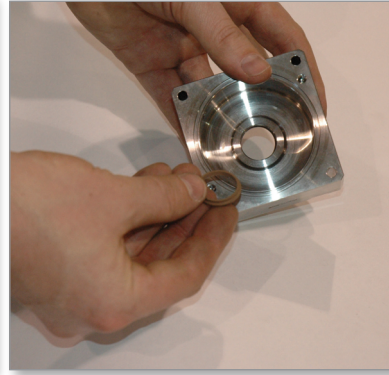
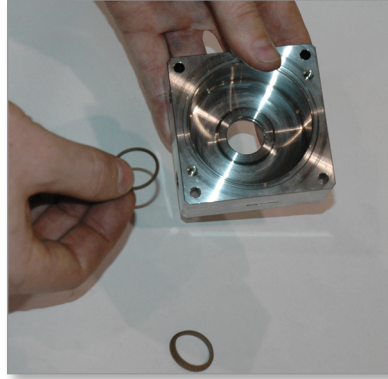

2. Use the piston to push the seal into position.
3. Install the rod wiper seal (2 pieces).

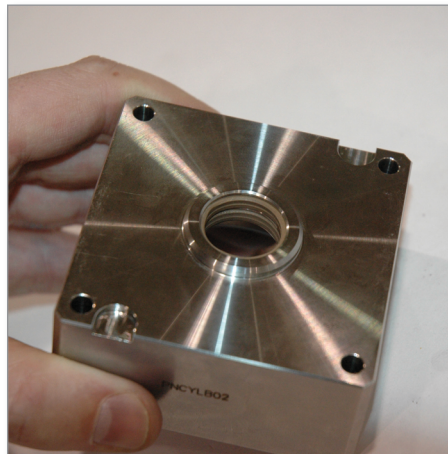
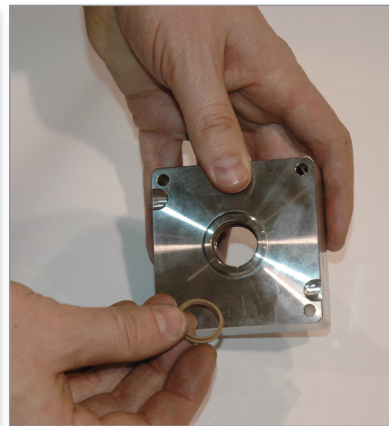
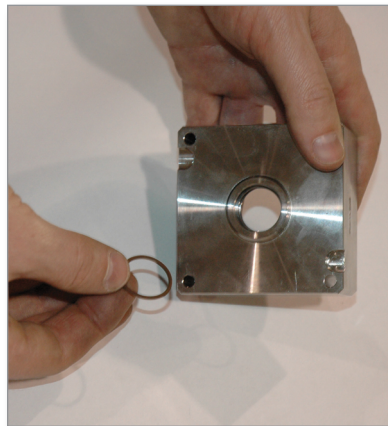

4. Use the piston to push the seal into position.

5. Install the piston seals (2 pieces).

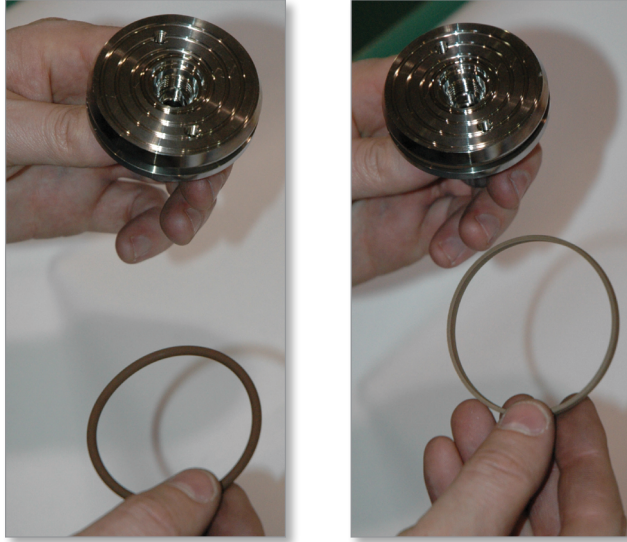

6. Install the piston top.
7. Tighten the piston top.



NOTE

Use soft vise jaws with cutout for piston body to prevent damage to the part.

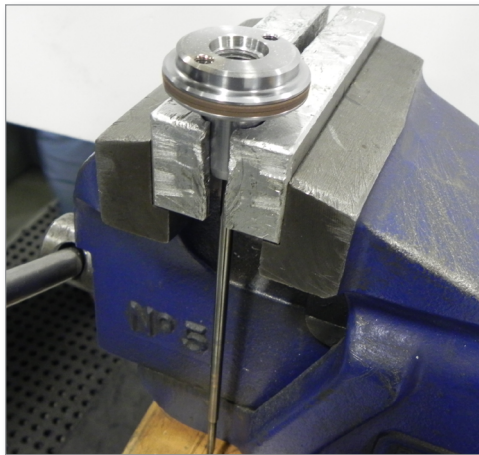

8. Assemble the piston into the cylinder body.

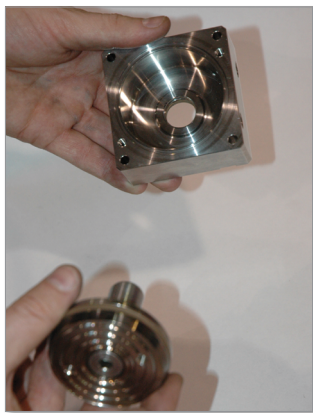

9. Install the cylinder top seal.

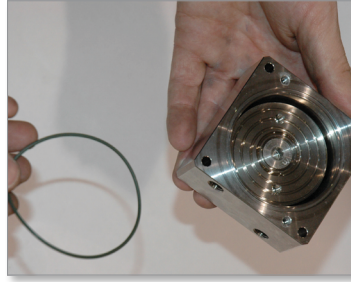

10. Assemble the cylinder top to the cylinder body.

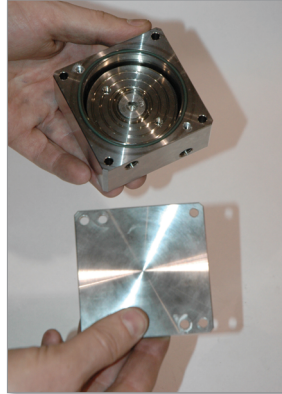

11. Apply anti-seize compound to the screws.
12. Install the cylinder top screws.
13. Install the piston collar in the cooling plate.

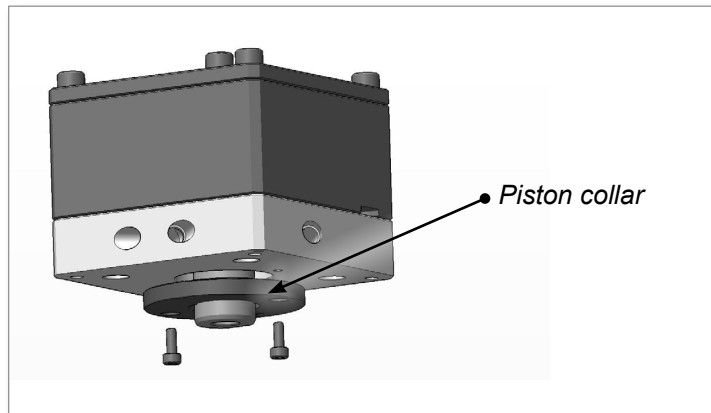

5.6.2 Pneumatic System Installation

1. Install the spacers on top of the manifold or valve disk flange.

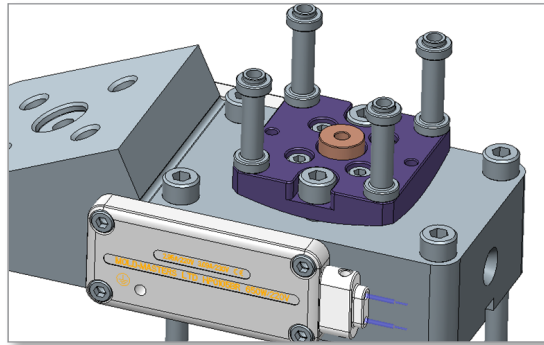

2. Locate the pneumatic cylinder cooling plate onto the spacers. Make sure to align the fitting ports in the appropriate direction.

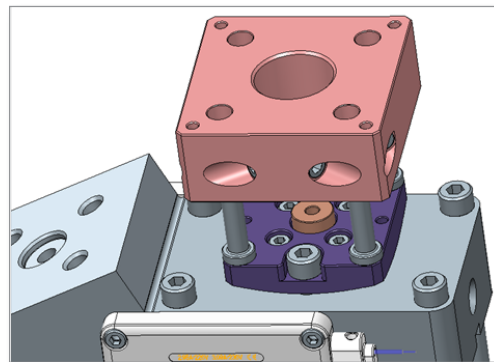

3. Apply anti-seize compound to screws.

Optional: Install anti-rotation collar to the bottom of cooling plate. Ensure proper alignment after reassembly.

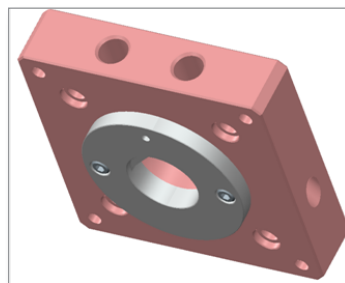

Pneumatic System Installation - continued

4. Torque screws in a crossing pattern gradually increasing torque to the specified value. Refer to the General Assembly drawing for torque values.

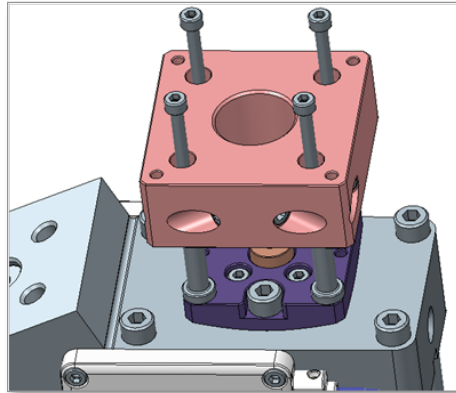

5. Place the cylinder housing onto the cylinder cooling plate.

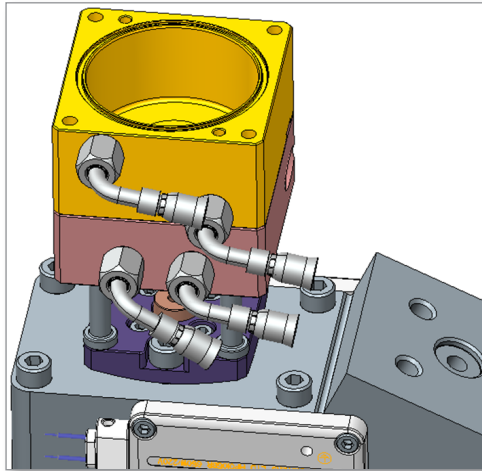

6. Insert the valve pin into the piston.



Pneumatic System Installation - continued

7. Apply anti-seize compound to the piston top.

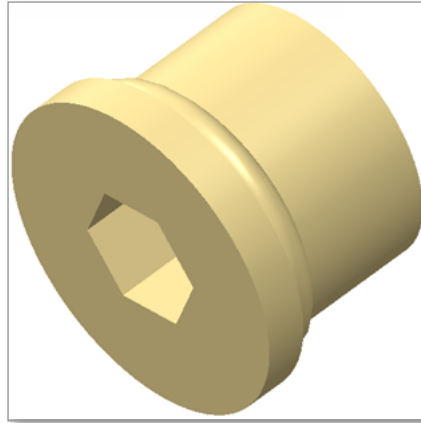

8. Install the piston top into the piston.



NOTE

Use soft vise jaws with cutout for piston body to prevent damage to the part.

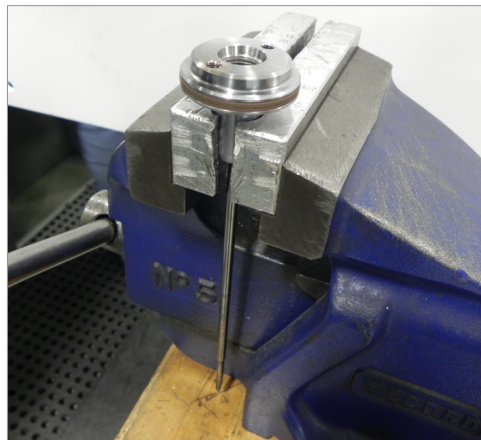

9. Install the piston into the cylinder housing.

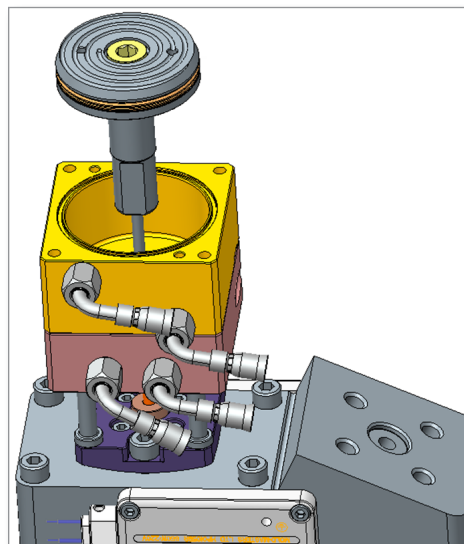

Pneumatic System Installation - continued

10. Install the cylinder top O-ring.

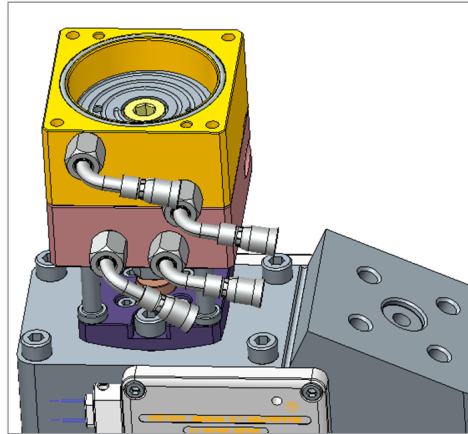

11. Install the cylinder top.

12. Apply anti-seize compound to the screws and torque the screws in a crossing pattern, gradually increasing torque to the specified value. Refer to the General Assembly drawing for torque values.

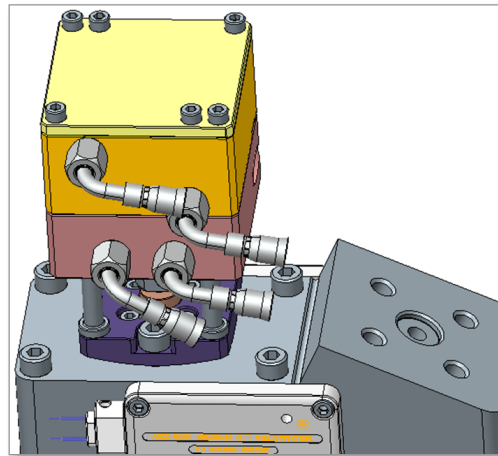

5.6.3 Install Hydraulic Actuator Assembly

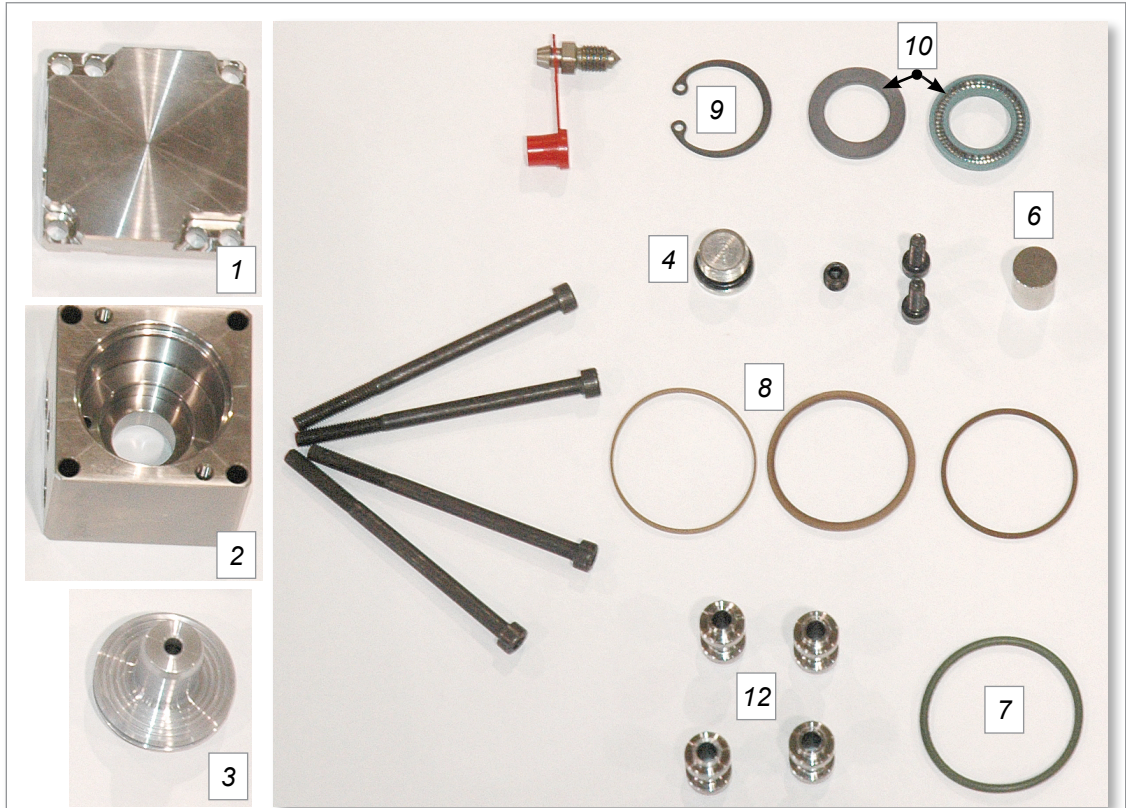

Hydraulic cylinder components

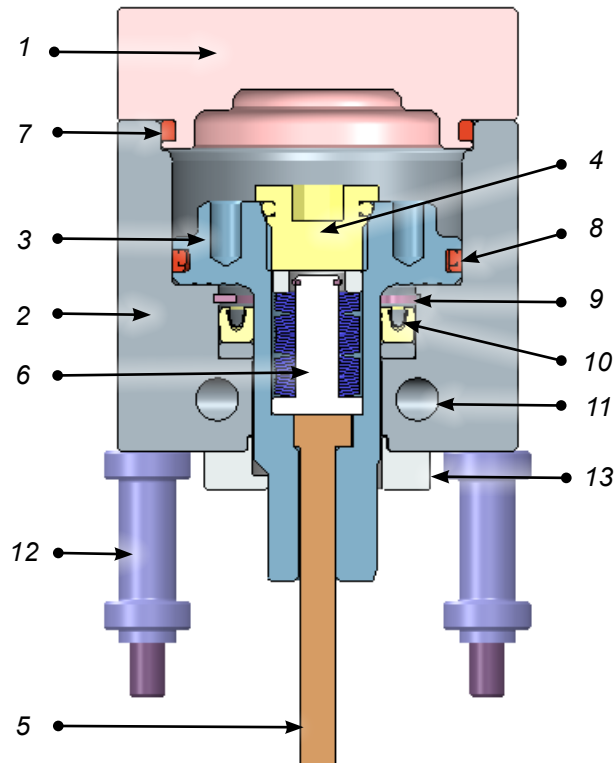

- 1. Cylinder top
- 2. Cylinder body
- 3. Piston bottom
- 4. Piston top
- 5. Valve pin
- 6. Spring pack
- 7. Cylinder top seal
- 8. Piston seals
- 9. Retaining ring
- 10. Rod seal
- 11. Cooling channel
- 12. Support spacer
- 13. Valve pin anti-rotation collar

Hydraulic cylinder section view

Figure 5-3 Hydraulic cylinder assembly components

Install Hydraulic Actuator Assembly - continued

1. Place the two pieces that make the rod seal into the pocket of the cylinder body.

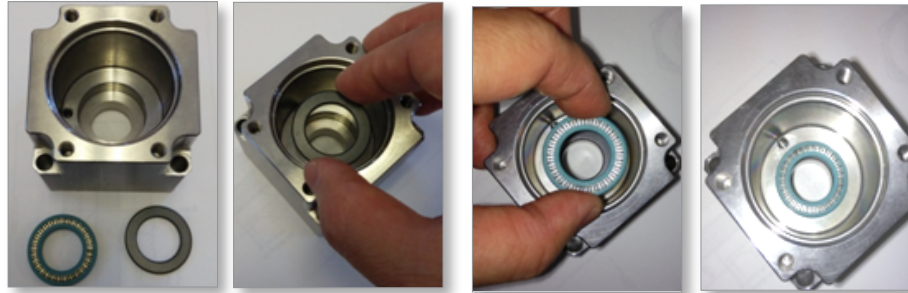

2. Press the seals into the housing.

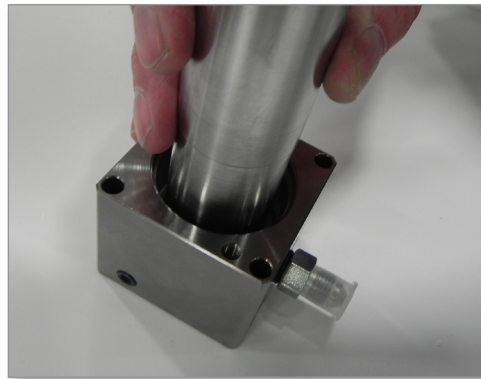

3. Install the rod seal retainer clip.

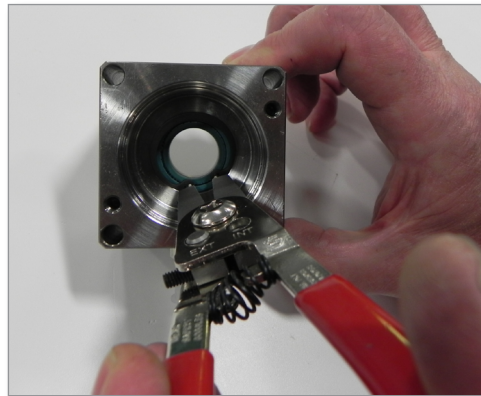

Install Hydraulic Actuator Assembly - continued

- 4. Place pipe sealant on threads of the water circuit pipe plug. Install the water circuit pipe plug.

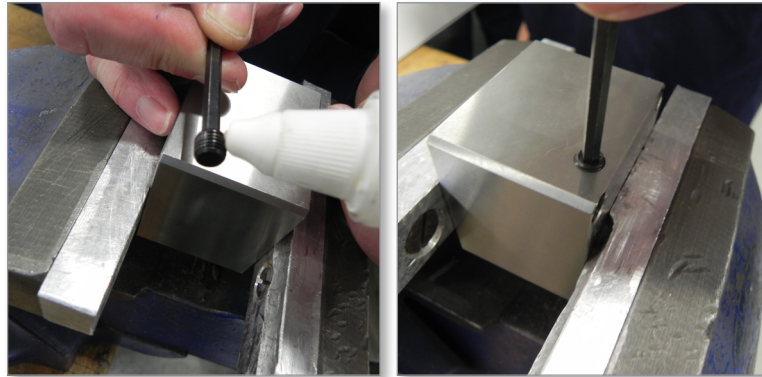

- 5. Install the piston seals (3 pieces).

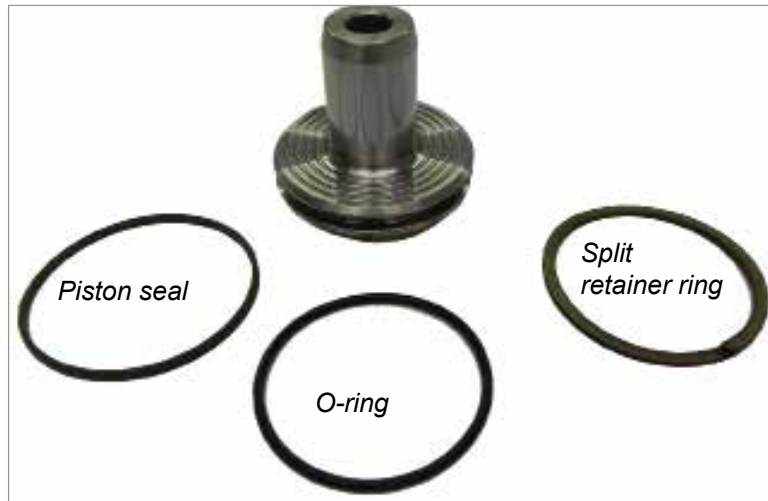

- 6. Install the O-ring.



Install Hydraulic Actuator Assembly - continued

7. Install the piston seal.

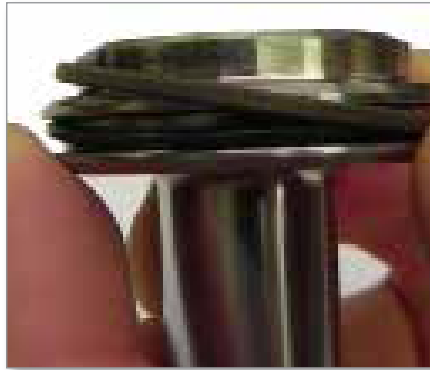

8. Install the split retainer ring.



9. Install the valve pin.

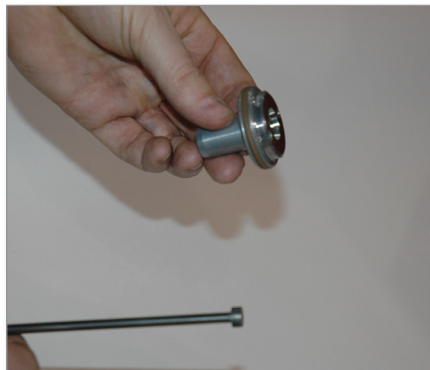

Install Hydraulic Actuator Assembly - continued

10. Install the spring pack.



11. Install the piston top.

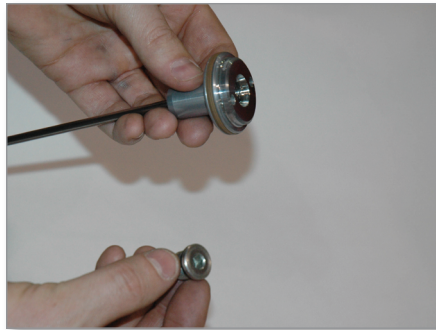

12. Tighten the piston top.



NOTE

Use soft vise jaws with cutout for piston body to prevent damage to the part.



13. Install the cylinder top seal.

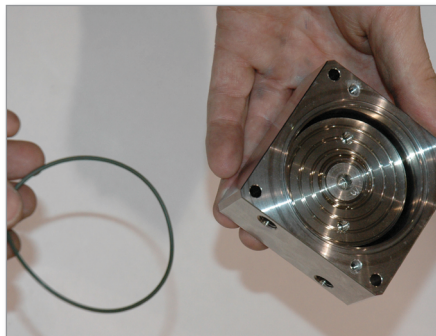

Install Hydraulic Actuator Assembly - continued

14. Assemble the piston into the cylinder body.

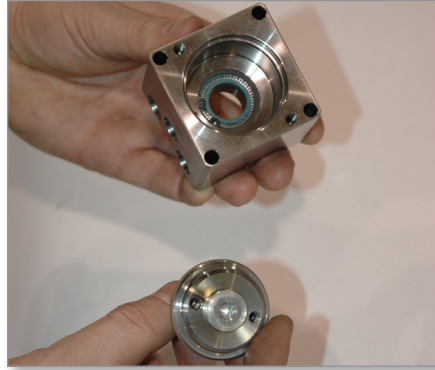

15. Assemble the cylinder top to the cylinder body.

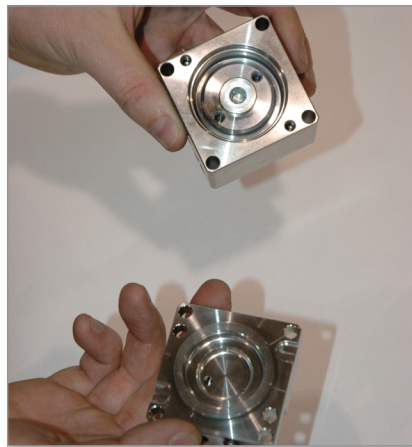

16. Apply anti-seize compound to the screws. Install the cylinder top screws.

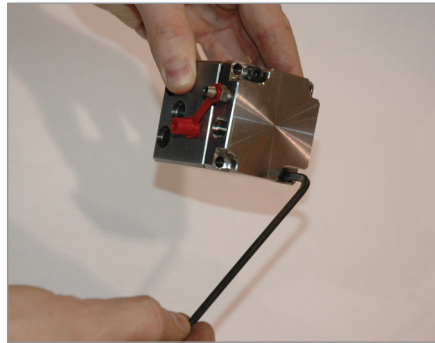

5.7 Install Heater Plates

1. Apply anti-seize compound to the screws (M6).
2. Bolt and torque screws in a cross pattern, gradually increasing torque to specified value. Refer to the General Assembly drawing for torque values.

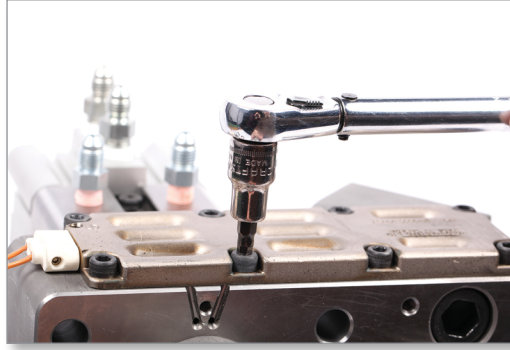

5.7.1 Install Heater Plate Thermocouple

These procedures apply to systems with external heater plates. Refer to the General Assembly drawing to determine which heater plate applies to your system.



NOTE

The controlling thermocouple for the heater plates is located in the heater plates.

The controlling thermocouples for the heater elements are located in the manifold.

1. Insert the thermocouple into the bore. Ensure the thermocouple is touching the bottom of the bore hole.
2. Press down on the thermocouple and gently bend to 90°.

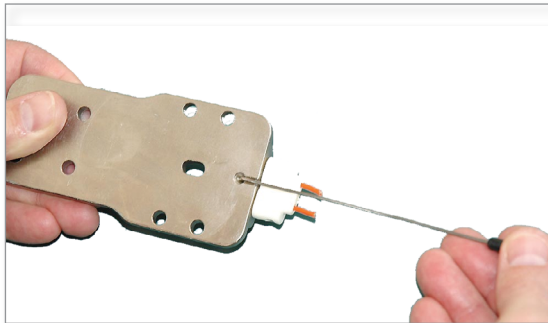

5.7.2 Install Heater Plates



CAUTION

This is a pinch point area. Use caution when installing the heater plate to the manifold plate. Failure to do so could result in damage to the thermocouple.

Do not overtighten the mounting screws. This could result in the heater plate losing contact with the manifold plate.

Refer to the General Assembly drawing for the correct torque values.

It is recommended that the heater plate wires be isolated and grouped so that they do not have to be disconnected if the manifold needs to be dismantled for repair.

1. Install the heater plate to the manifold. Refer to the General Assembly drawing for location. Use anti-seize compound on threads. Bolt and torque screws in a crossing pattern, gradually increasing torque to specified value. Refer to the General Assembly drawing for torque values.

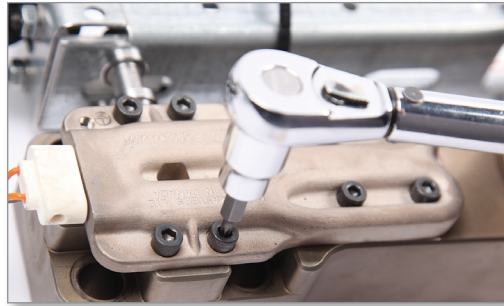

2. The heater plates are supplied with the power wires connected. Place a zone number on each wire and thermocouple.

5.8 Tubular Heater Installation and Replacement For Field Replacement of Flexible Heaters



WARNING

Heater elements should be installed by qualified personnel.

The heater element and heated block must be connected and grounded during maintenance according to local electrical standards, e.g. DIN EN 60204-1 or NFPA79.



CAUTION

Mold-Masters only recommends field replacement of flexible heater elements only. We do not recommend field replacement of heater elements that are brazed or pasted into the manifold. For these types of heater elements, please contact your service representative.

5.8.1 Storage

Heater elements should be stored at room temperature and in a dry atmosphere.

The heater element insulation material attracts and hold moisture. If there is a chance it has been exposed to humidity during storage, then the insulation resistance should be confirmed prior to installation ($R_{min} = 5 \text{ M}\Omega$ at 500 V DC). If necessary, heating elements should be dried at a temperature of 120°C (250°F) for a few hours.

5.8.2 Remove a Heater Element

1. Disassemble wires and ceramic terminal connector from the failed heater element. Label the wires to identify them for reassembly.
2. Use pliers to lift the heater element's exit portion and insert a brass stick below the heater element. Pull the heater element out of the groove while prying it up with the brass stick.
3. Clean the manifold heater element groove with a brass brush and make sure there is no contamination or sharp edges.

5.8.3 Install a New Heater Element



CAUTION

To protect the heat element from failure at startup, we highly recommend using the soft start feature on the controller.

Use a plastic (nylon) mallet only. A regular soft rubber hammer will not work. A smaller head size is preferred. Do not use a metal hammer. It will damage the heater and the manifold surface.

1. Prior to installation, check the General Assembly drawing for the correct heater element size and confirm the replacement conforms.
2. Check that the connection voltage does not exceed the heater element's operating (nominal) voltage.
3. Remove the spare nut and washers supplied on the threaded heater element pin. Tighten the remaining nut, next to the ceramic ring, to 1 Nm to provide proper sealing and protection.



4. Align the center of the heater element to the centre marking on the manifold groove. Always start the heater element installation from the middle point of the path. We recommend installing the heater element gradually from both sides in parallel. This will help to get an equal exit length.



Install a New Heater Element - continued

5. Use a plastic (nylon) mallet to tap the element straight down into the groove. This will help to prevent the heater element from stretching.



6. For the curved areas of the groove, pre-bend the heater element manually before hammering it into the groove. This will prevent the shielding from being damaged by the groove edge.
7. Make sure the heater element is completely seated inside the groove. The heater element should be 0.5 mm lower than the top surface.

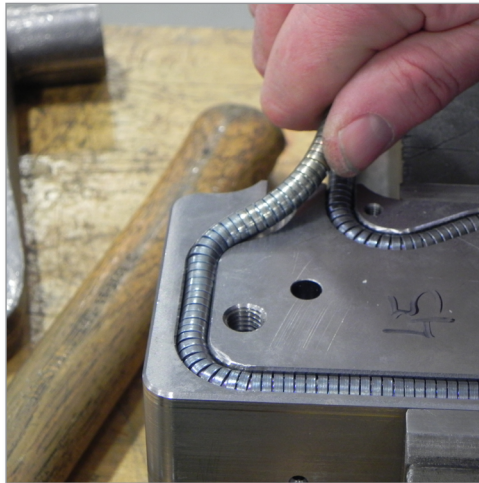

8. Do not bend the unbendable zones of the heater element. This is the last 35 mm (1.4 in) area on each end. See below:

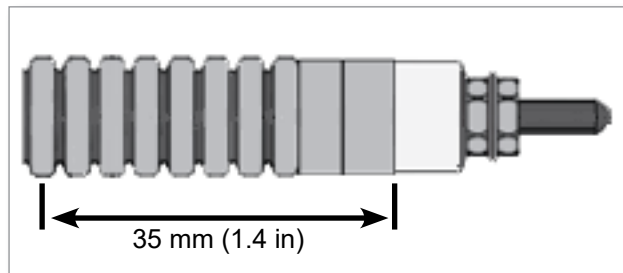

Install a New Heater Element - continued

9. Crimp the wire with the proper size crimper pin. Connect it to the heater threaded pin with the ceramic terminal connector.



10. After all connections are finished, test the electrical connections to proper electrical standards.



5.9 Bridge Assembly

5.9.1 Installation of Inlet Components



CAUTION

For all inlet components it is important that the mold locating ring is touching the inlet component just enough for sealing the area. This should be double checked with the system drawings.

Ensure the machine nozzle opening matches the melt entrance for the Hot Runner system, or is not more than 1.0 mm (0.040") smaller.

The following procedures refer to different system configurations. Refer to your parts list and General Assembly drawings to determine your system type.

5.9.2 Heated Back Plate Installation

The center heater may require the machine nozzle radius to be added.

1. Check the machine nozzle radius.
2. Check the seating on the bottom face of the back plate and manifold using die-spotting blue compound.

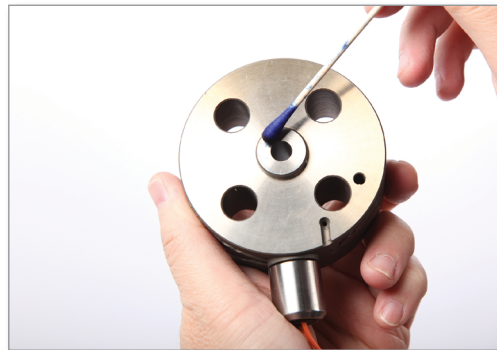

3. Clean die-spotting blue compound off all components.
4. Place the center heater on the manifold.
5. Rotate the center heater to align with the tapped holes in the manifold and align terminals with cutout.
6. Install mounting screws through the center heater into the tapped holes of the manifold. Use anti-seize compound on the screws.



Heated Back Plate Installation - continued

7. Torque screws. Refer to the General Assembly drawing for torque values.

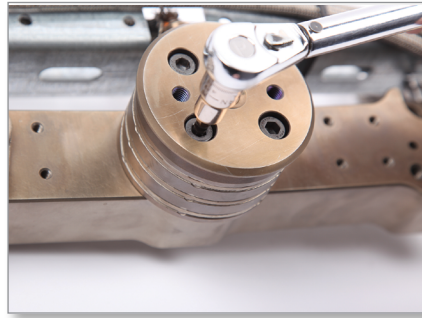

8. Place a zone number on each wire and thermocouple.
9. Tape wires for each zone together.
10. Install the wires into the wire channels and secure with high temperature cable ties.
11. Feed wires back through the wire channel in the mold base to the electrical box.

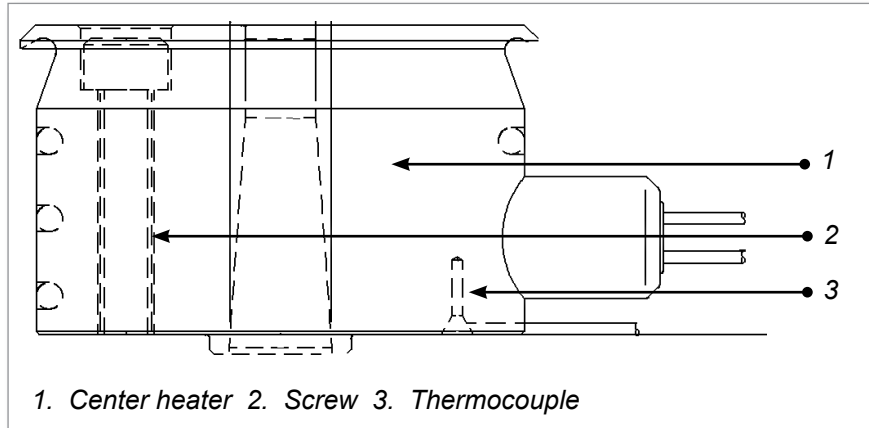
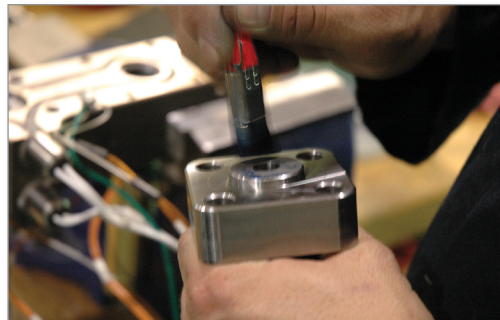

Figure 5-4 Back plate (heated)

5.9.3 Inlet Extension with Heater Sleeves

1. Apply die-spotting blue compound to bottom of inlet.



Inlet Extension with Heater Sleeves - continued

2. Apply anti-seize compound to the screws and install inlet to manifold.



3. Torque screws in a crossing pattern, gradually increasing torque to specified value. Refer to the General Assembly drawing for torque values.

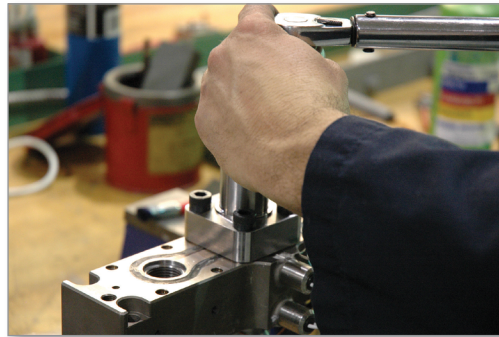

4. Remove inlet to verify blue surfaces.
5. Clean the die-spotting blue compound from the inlet and manifold.

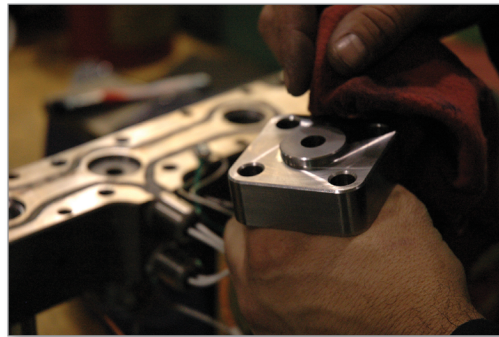

6. Reinstall inlet. Torque screws in a crossing pattern, gradually increasing torque to specified value. Refer to the General Assembly drawing for torque values.

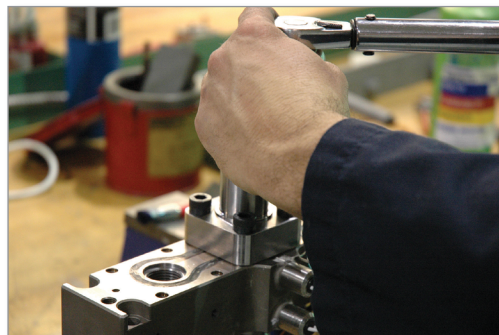

Inlet Extension with Heater Sleeves - continued

7. Apply die-spotting blue compound to the inlet seal and verify these surfaces to check fit of seal in the inlet.

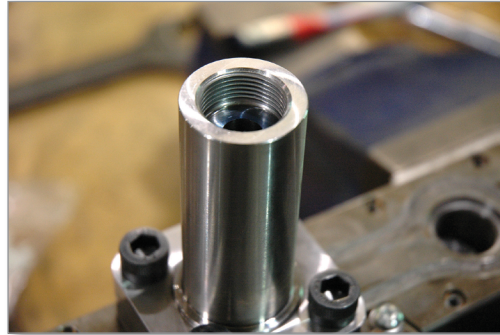

8. Clean die-spotting blue compound from inlet seal and inlet.



9. Install inlet heaters and sleeves as per specified drawing.

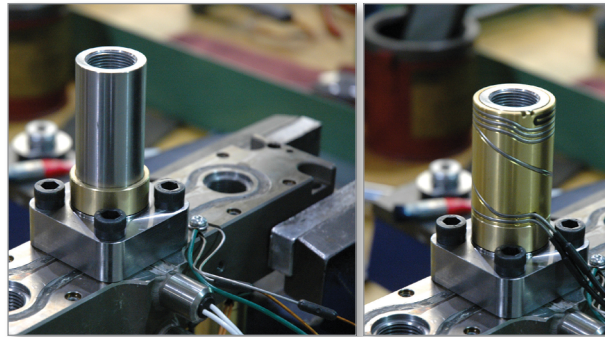

10. Apply anti-seize compound to threads and install inlet seal to inlet.

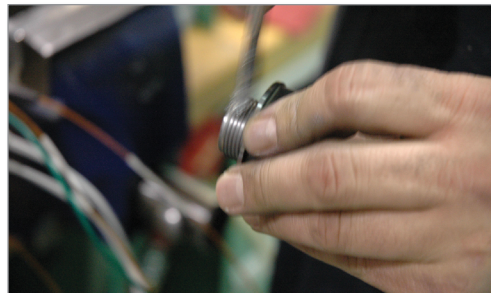

Inlet Extension with Heater Sleeves - continued

11. Torque to specified value. Refer to the General Assembly drawing for torque values.



12. Install thermocouple into slot until it bottoms out.



13. Bend 180 degrees.



14. Install thermocouple clip.



5.9.4 Wiring Channel

The wiring channel connects the electrical system, control system and cooling system to the Hot Runner system. It collects the wires and hoses from the control and cooling systems and routes them to the customer interface components. All wires for power and control are collected in an intermediate space, and it routes the hoses for control and cooling above the wiring channel for protection. All wire channels are custom designed to suit. See your General Assembly drawing for specific details.

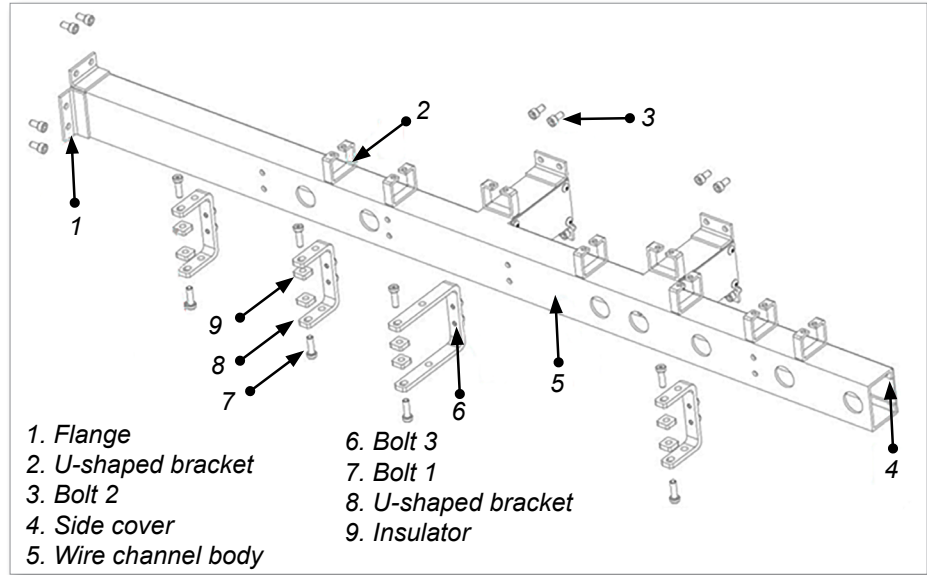

Figure 5-5 Wiring channel

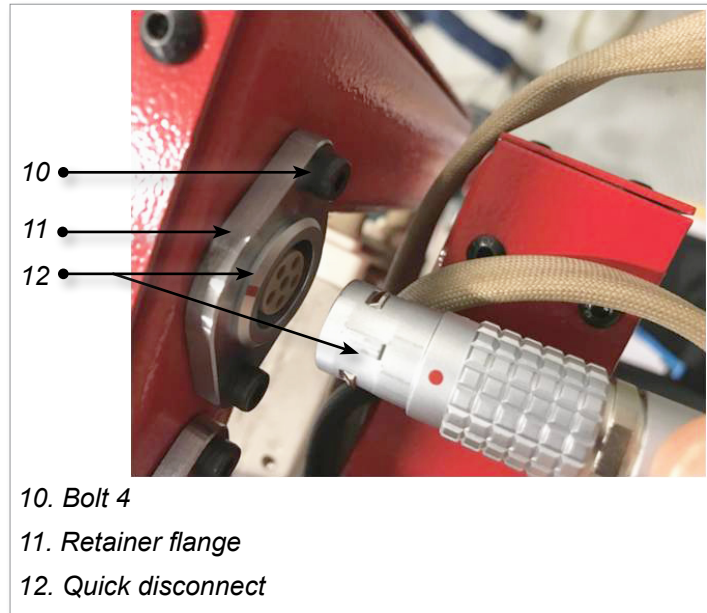

Figure 5-6 Wiring channel quick connect

5.9.4.1 Wiring Channel Components

1. Flange: allows for secure connections of power / control / cooling to customer interface component
2. U-shaped locker: supplies protection and fastening points for actuator pressure and cooling water hosing
3. Bolt 2: used to mount interface components to the wiring channel
4. Side cover: protects wires in the wiring channel body, improves the strength of the structure and provides easy maintenance access
5. Wiring channel body: the material of wiring channel is structural carbon steel, ensuring strength, and the hollow space inside allows wires for power, thermocouple and controls
6. Bolt 3: used to mount the wiring channel body and U-shaped bracket
7. Bolt 1: used to mount the U-shaped bracket and Hot Runner manifold
8. U-shaped bracket: joins the Hot Runner system and the wiring channel body with two holes for function extension
9. Insulator: prevents heat transfer from the manifold to the wiring channel, when the process temperature is above 320°C
10. Bolt 4: attaches the retainer flange to the wiring channel
11. Retainer flange: the mounting flange which attaches the fixed socket to the wiring channel, if required
12. Quick disconnect: consists of a straight plug and a fixed socket. The straight plug is attached to the fixed socket, which allows for quicker installation and removal of prewired sub assemblies

5.10 Sub-Manifold Wiring



CAUTION

All wires close to a heat source require high temperature sheathing.

5.10.1 Power Wiring

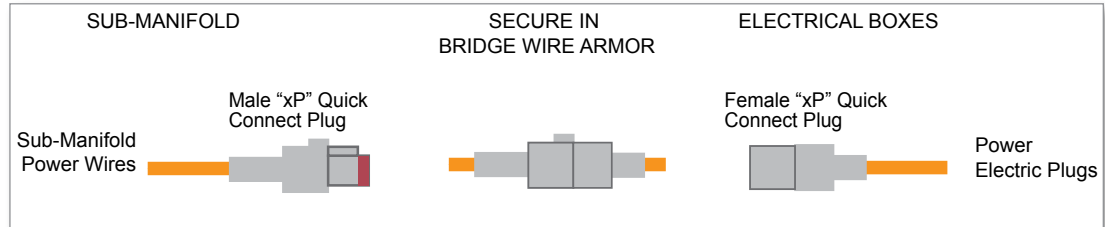

1. Run all the power wires to the bridge and locate a position for quick connector sitting, and cut the wires to a proper length.
2. Label the wires and install high temperature sheathing.
3. Crimp all heater plates and nozzle power wires with female contacts.
4. Insert the power wires contacts into the male plug of quick connector '1P' per wiring schematic in General Assembly drawing.
5. Insert the coding pin to the male plug as per wiring schematic, if applicable.
6. Get six spare wires crimped with male contacts in one end, insert into the female plug of quick connect '1P', and label the wires according to the male side.
7. Snap '1P' plugs together. Run the open end of the wires to the electrical plugs. Cut the wires to the proper length and crimp them. Install high temperature sheathing if needed.
8. Install the power wires into electric plugs per wiring schematic in the General Assembly drawing.
9. Repeat above for each zone. Name connector number according to drop number. Be sure to locate the connectors inside the wire armor. See 5.9.4 Wiring Channel on page 5-42 for further details.

5.10.2 Thermocouple Wiring

1. Run all the thermocouple wires to the bridge wire armor and locate a position for quick connector sitting. Cut the wires to a proper length.

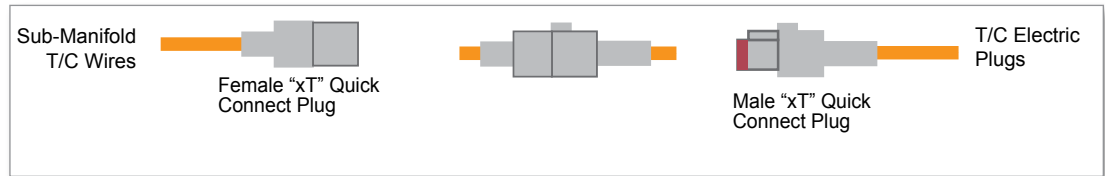

2. Label the wires and install high temperature sheathing.
3. Crimp all thermocouple wires with male contacts.
4. Insert the thermocouple wire contacts into the female plug of quick connector '1T' as per wiring schematic in the General Assembly drawing.
5. Get six spare wires crimped with female contacts in one end, insert into the male plug of quick connect '1T', and label the wires accordingly to the female side.
6. Insert the coding pin to the male plug as per wiring schematic, if applicable.
7. Snap '1T' plugs together, run the open end of the wires to the electrical plugs, cut the wires to the proper length and crimp them. Install high temperature sheathing if needed.
8. Install all the thermocouple wires into electric plugs per wiring schematic drawing in the General Assembly drawing.
9. Repeat above for each zone. Name connector number according to drop number. Be sure to locate the connectors inside the wire armor. See 5.9.4 Wiring Channel on page 5-42 for further details.

5.10.3 Prepare to Wire the Bridge



CAUTION

All wires close to a heat source require high temperature sheathing.

1. Group thermocouple and heater wires for a single zone together and install high temperature wire sheathing.
2. Label all heater and thermocouple zones.
3. Use heat resistant tape to group thermocouple heater zones together and to avoid losing labels.
4. Repeat for all zones.

5.10.4 Wiring Channel Installation



WARNING - BODY CRUSH HAZARD

During installation of the wiring channel, a crushing hazard exists between the wiring channel and the manifold and any other accessories that may be mounted to the wiring channel.



WARNING

When doing any work that requires moving and lifting the wiring channel, connect all lifting devices and support the machine using a crane of adequate capacity before commencing work. Failure to support the machine can result in severe injury or death.

The screws securing the wiring channel to the manifold and / or other accessories must be tightened to the correct torque. See Table 11-3 Torque Chart for System Assembly Screws on page 11-13.



CAUTION

The wiring channel presents a tip / crush hazard when being moved.

1. Inspect the wiring channel before installation.



2. Mount the wiring channel to the manifold from the side. The slot holes of U-shaped bracket must align with the manifold mounting holes.

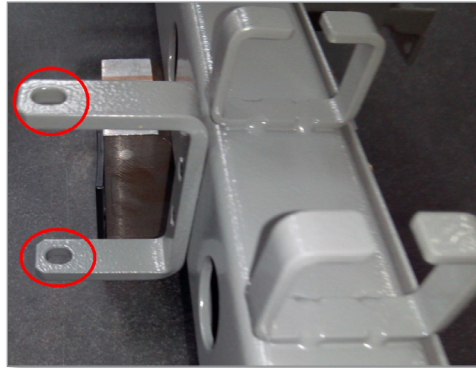

3. Mount any other accessories or adapter plates to the wiring channel.



Wiring Channel Installation - continued

4. Unscrew the bolts and remove the side covers.

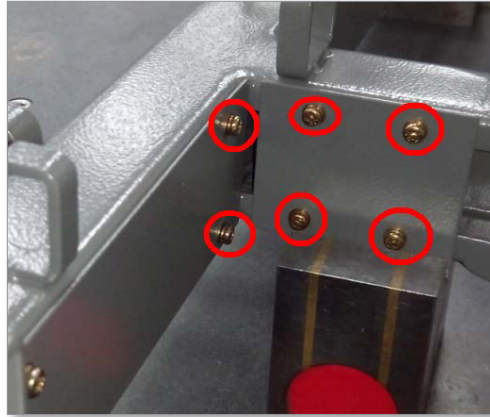

5. Organize all sorted power, thermocouple and other control wires to the wiring channel then install side covers.

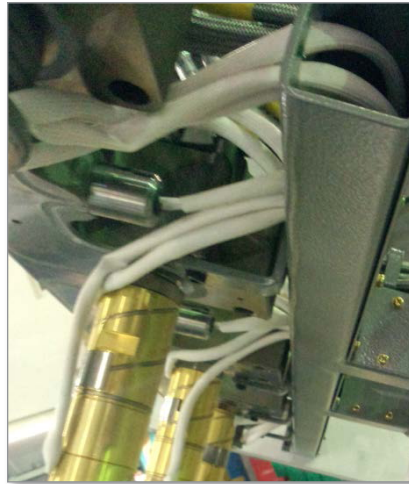

6. Run all hoses above the wiring channel. Fasten to the U-shaped bracket, if needed.

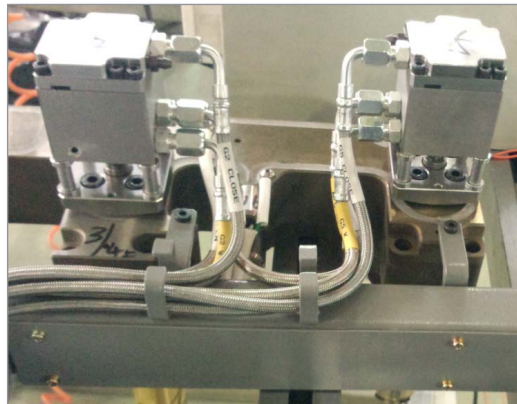

Wiring Channel Installation - continued

7. Inspect wires and hoses. Wires must not be overstretched. Hoses must be held at the proper bending angle. All hoses must be run through the U-shaped bracket.

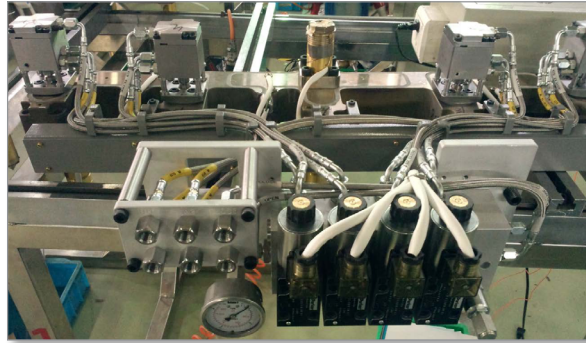

5.10.5 Electrical Box

1. Install plugs into electrical box.

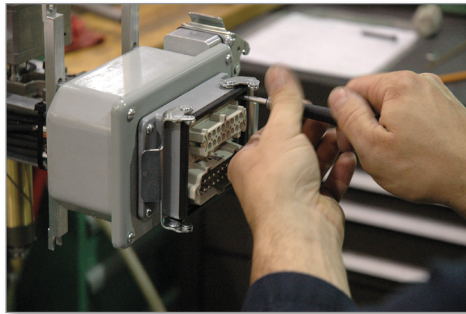

5.10.6 Solenoid Valve Wiring

1. Install solenoid coil wires into electrical plugs as per wiring schematic in General Assembly drawings.

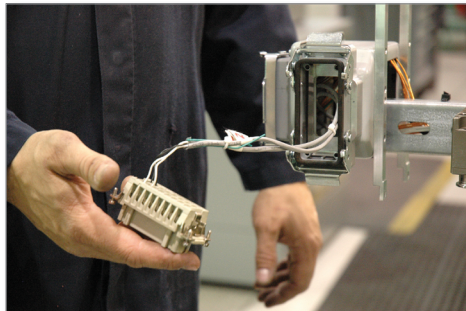

2. Install plugs into electrical box.

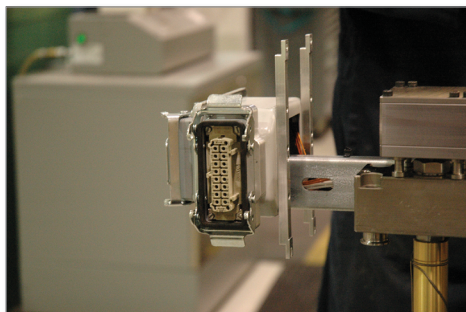

Section 6 - SeVG+ Actuator

Please see the SeVG+ user manual for information about SeVG+ assembly and operation.

Section 7 - Accu-Line

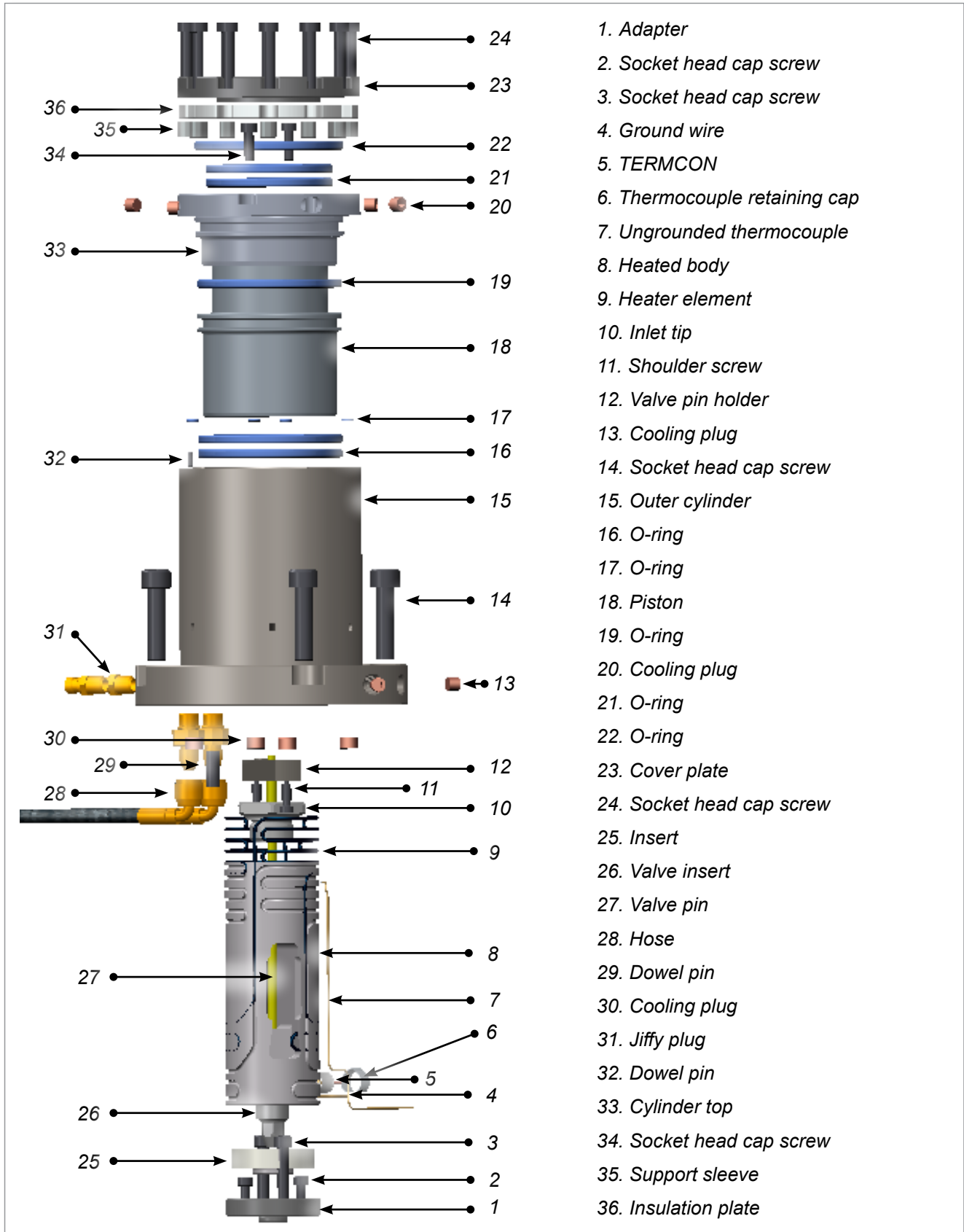

Figure 6-1 Accu-Line™ body assembly

7.1 Accu-Line with Valve Insert - Assembly



CAUTION

Verify the stroke height stated on the General Assembly drawing before and after installing the cylinder top into the assembly.

1. Check components against the parts list.

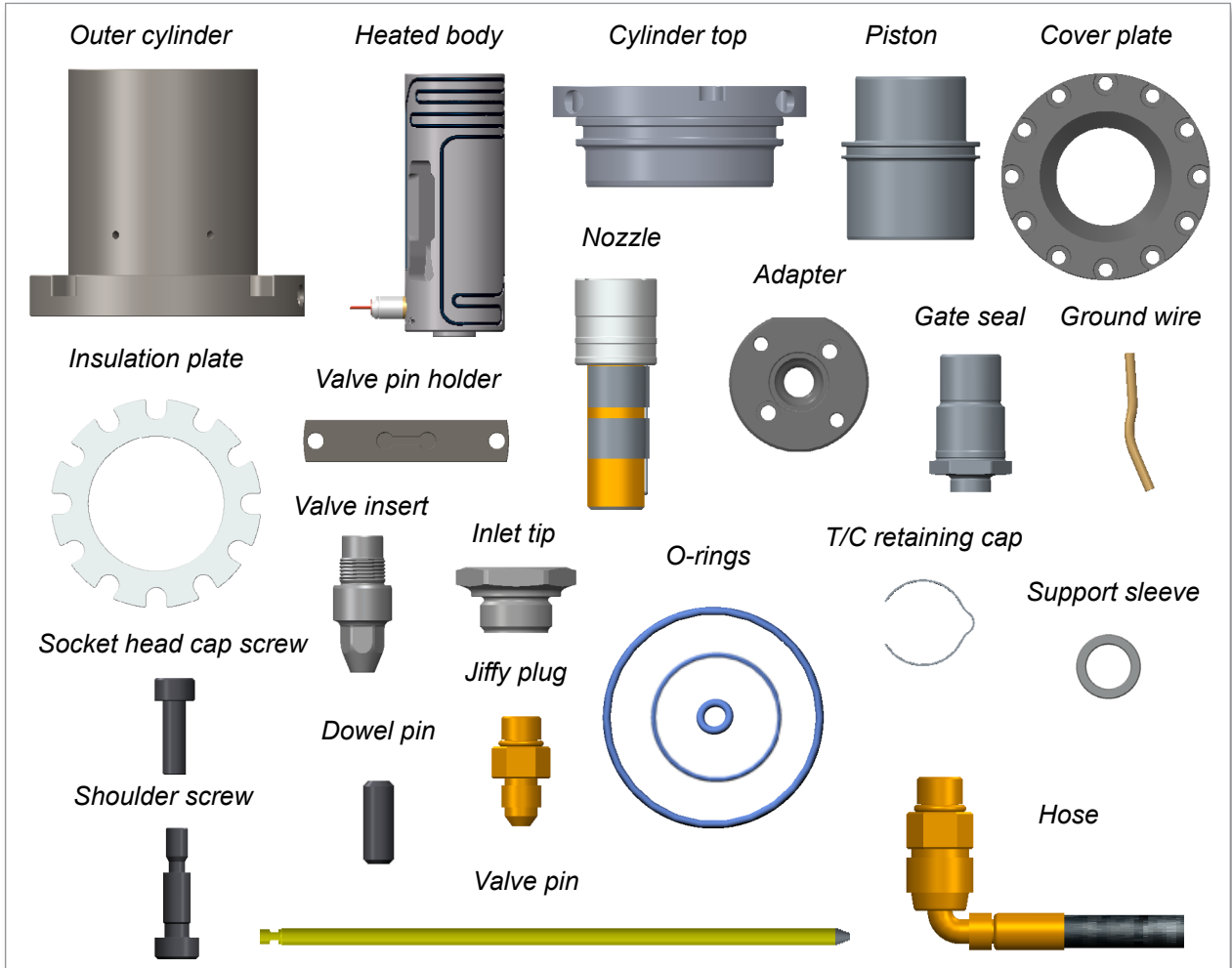

Figure 7-1 Components for Accu-Line™ non front mounted model

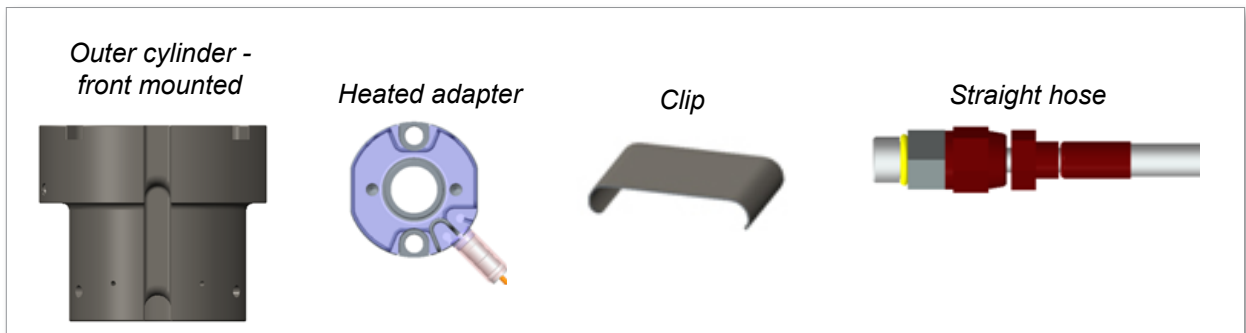
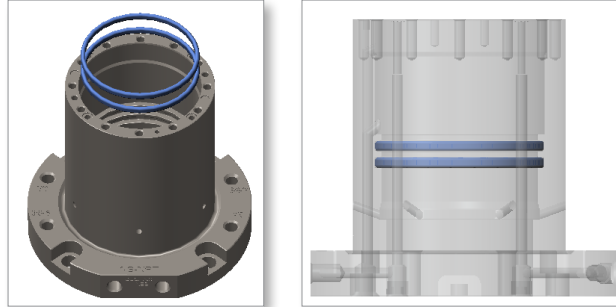

Figure 7-2 Additional components for Accu-Line™ front mounted model

Accu-Line with Valve Insert Assembly - continued

2. Apply grease to the O-ring assembly grooves in the inner surface of the cylinder.
3. Use your fingers and gently push the O-rings into the groove in the cylinder. Make sure that the O-rings seats firmly in the groove.

Non Front Mounted Model:



Front Mounted Model:

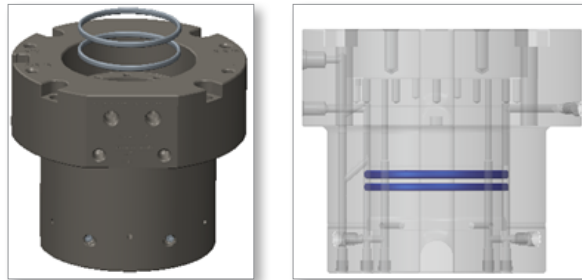

4. Insert the jiffy plugs for cooling connection into the supply ports of the cylinder.

Non Front Mounted Model:

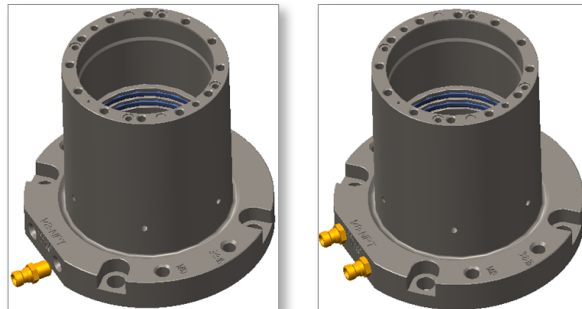

Front Mounted Model:

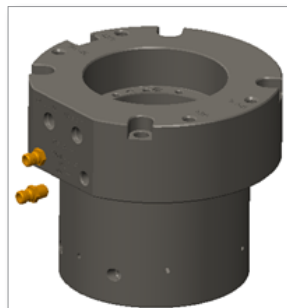

Accu-Line with Valve Insert Assembly - continued



IMPORTANT

Step 5 is optional for systems that have cooling lines within the plates. Please refer to the General Assembly drawing for the location of the bottom ports for cooling connections.

5. Insert the plugs into the supply ports of the cylinder and seal the lines.

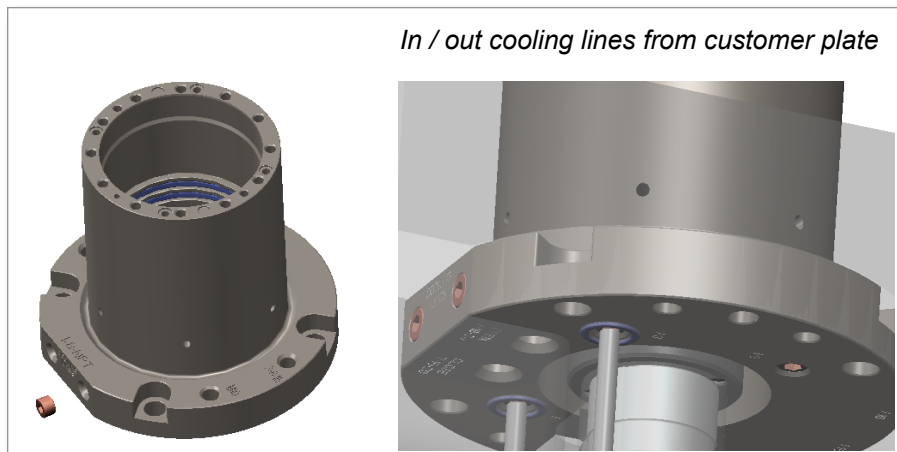

6. Apply grease to the O-ring assembly grooves in the outer surface of the piston.
7. Use your fingers and gently push the O-ring into the groove in the piston. Make sure that the O-ring seats firmly in the groove.

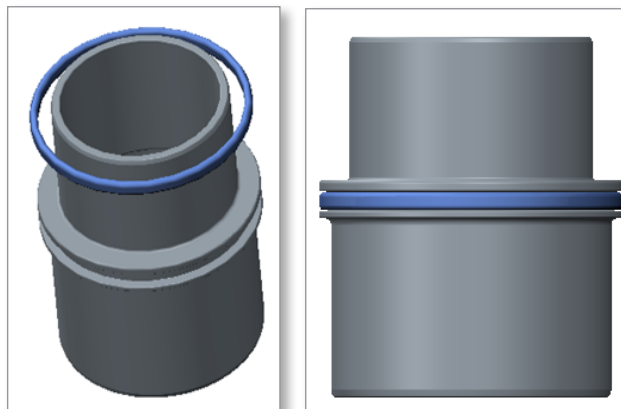

Accu-Line with Valve Insert Assembly - continued

8. Insert piston into the outer cylinder. Apply even force with both hands and gently press the piston until it seats evenly.



NOTE

Ensure that the top surface of the piston and cylinder are level with one another.

Non Front Mounted Models:

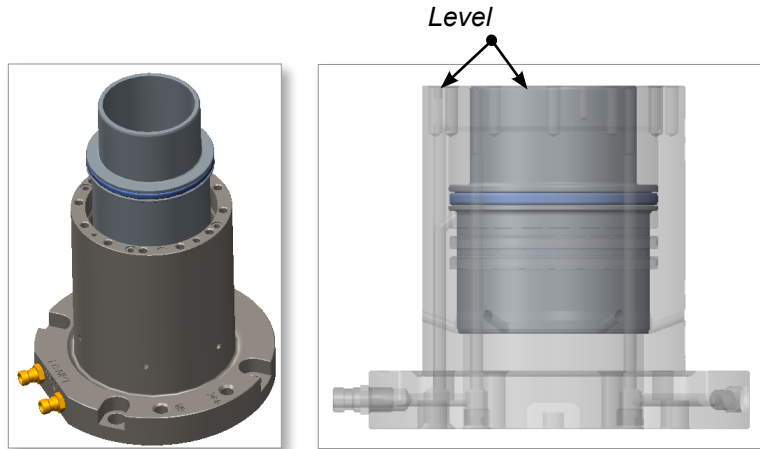

Front Mounted Models:

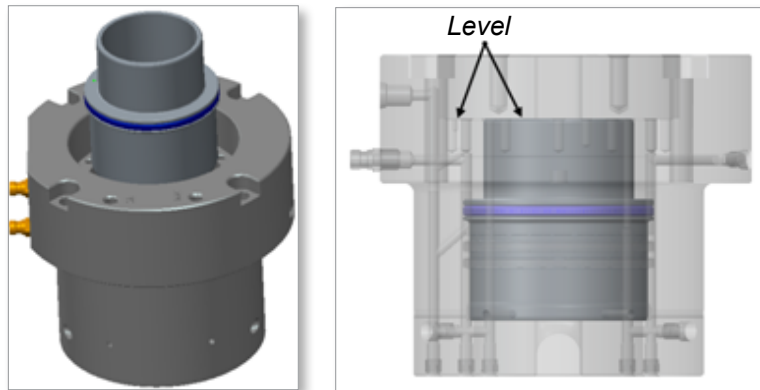

Accu-Line with Valve Insert Assembly - continued

9. Insert the dowel pin into the outer cylinder assembly.

Non Front Mounted Models:

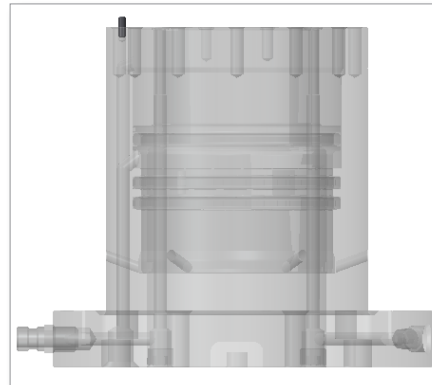
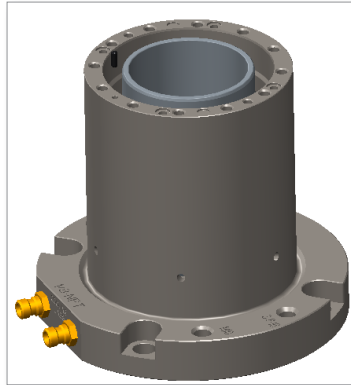

Front Mounted Models:

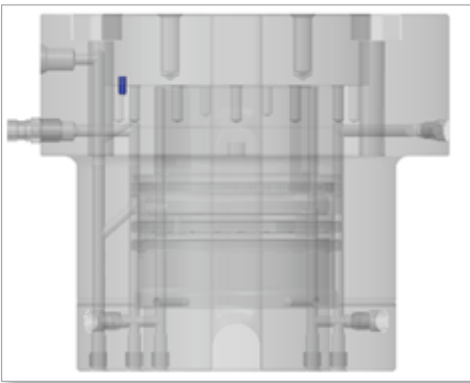
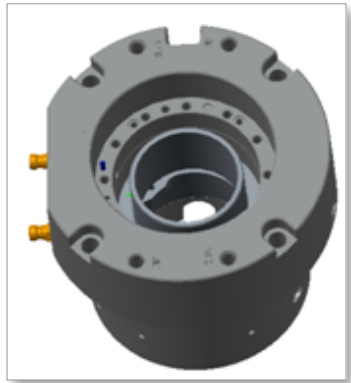

Accu-Line with Valve Insert Assembly - continued

10. Use fingers to gently push the O-rings into the outer groove in the cylinder.



NOTE

Ensure that the O-ring seats firmly in the groove.

Non Front Mounted Models:

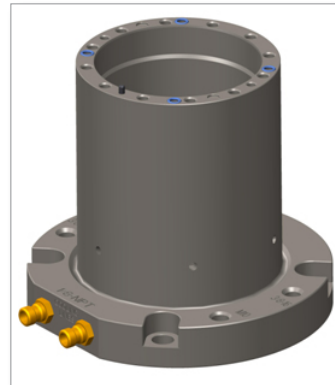
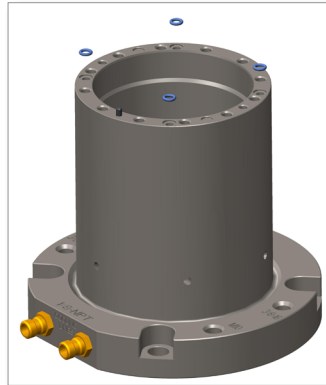

Front Mounted Models:

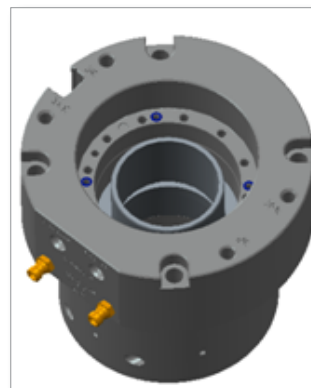
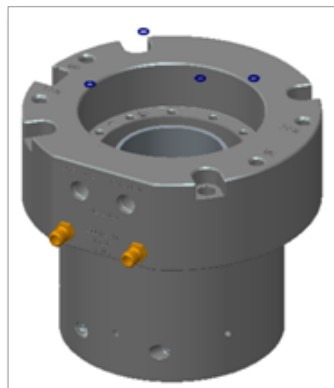

11. Apply grease to the O-ring assembly grooves in the inner and outer surface of the cylinder top.

Accu-Line with Valve Insert Assembly - continued

12. Use fingers to gently push the O-ring into the outer groove of the cylinder top.



NOTE

Ensure that the O-ring seats firmly in the groove.

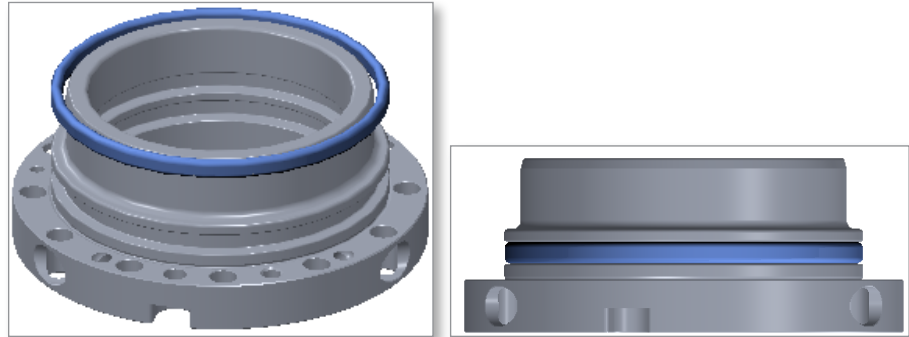

13. Use fingers to gently push the O-rings into the inner groove of the cylinder top.



NOTE

Ensure that the O-ring seats firmly in the groove.

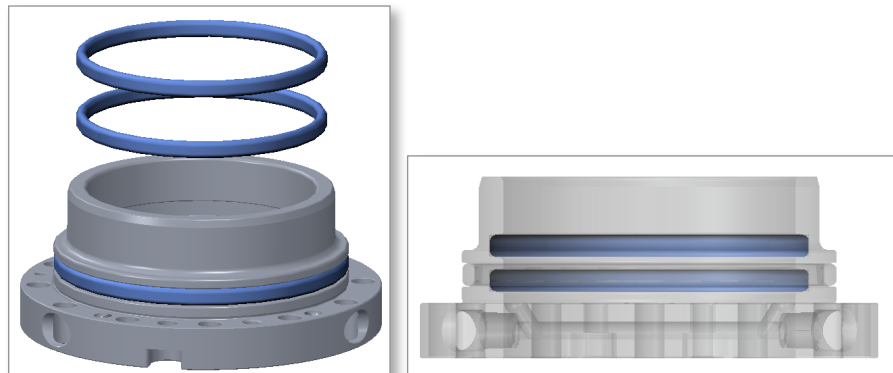

CAUTION

Verify the stroke height with the General Assembly drawing before and after installing the cylinder top into the assembly.

14. Install the cylinder top into the outer cylinder. Align the cylinder top with the anti rotation dowel.



NOTE

Ensure that the O-rings are not disturbed from their positions.

Accu-Line with Valve Insert Assembly - continued

15. Insert the screws and torque to 7 Nm (5 lbf-ft).

Non Front Mounted Models:

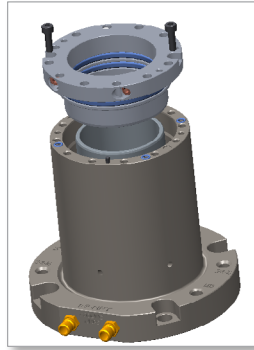

Front Mounted Models:

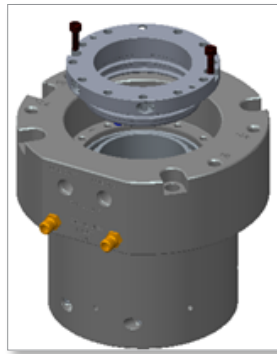

16. Place the insulation plate on the cylinder body and install the support sleeves.

Accu-Line with Valve Insert Assembly - continued

17. Place the cover plate on the insulation plate. Insert the socket head cap screws and torque to 14 Nm (10 lbf-ft).

Non Front Mounted Models:

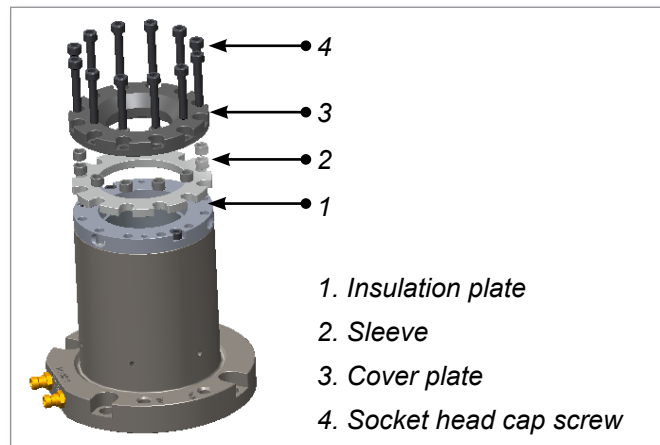

Front Mounted Models:

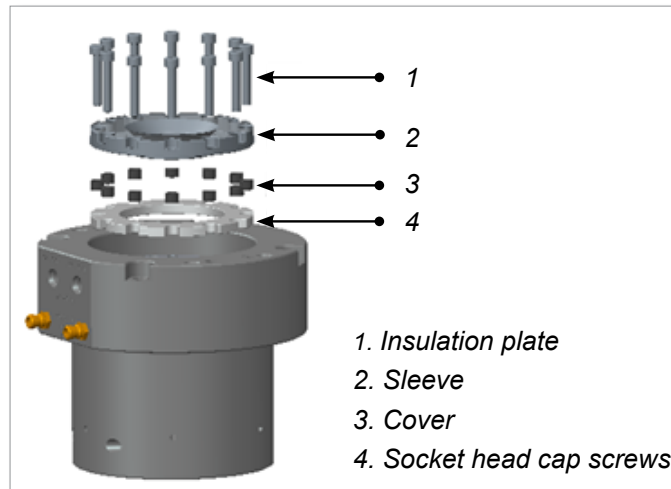

Accu-Line with Valve Insert Assembly - continued

18. Insert the actuator connection hose fittings to the supply ports.

Non Front Mounted Models:

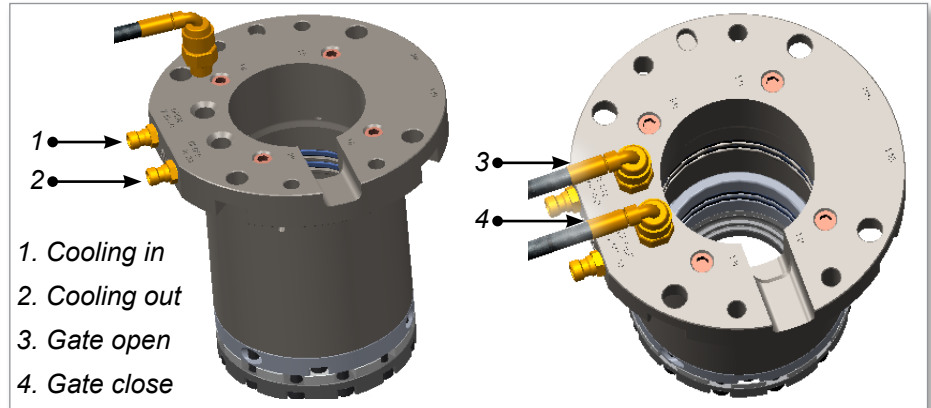

Front Mounted Models:

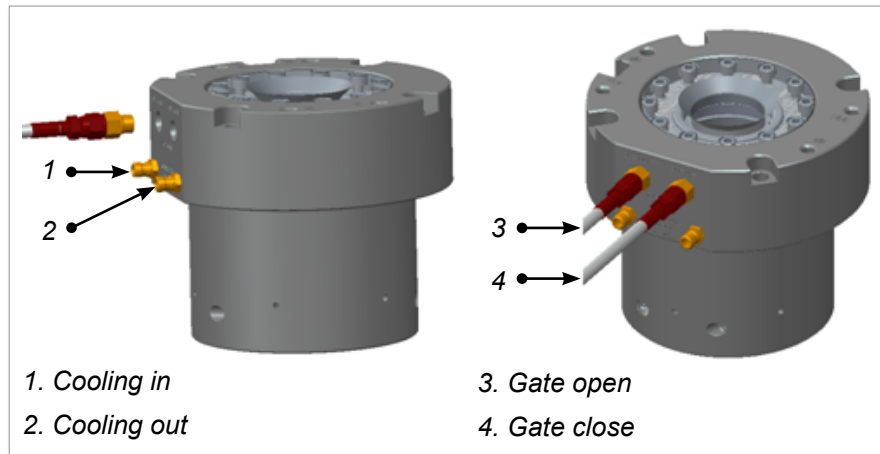

IMPORTANT

Steps 19 and 20 are optional for systems that contain actuation connections within the plates.

19. Install the actuation connections into the bottom supply ports of the cylinder.

Accu-Line with Valve Insert Assembly - continued

20. Pressure test the cooling connection to ensure that there is no leakage.

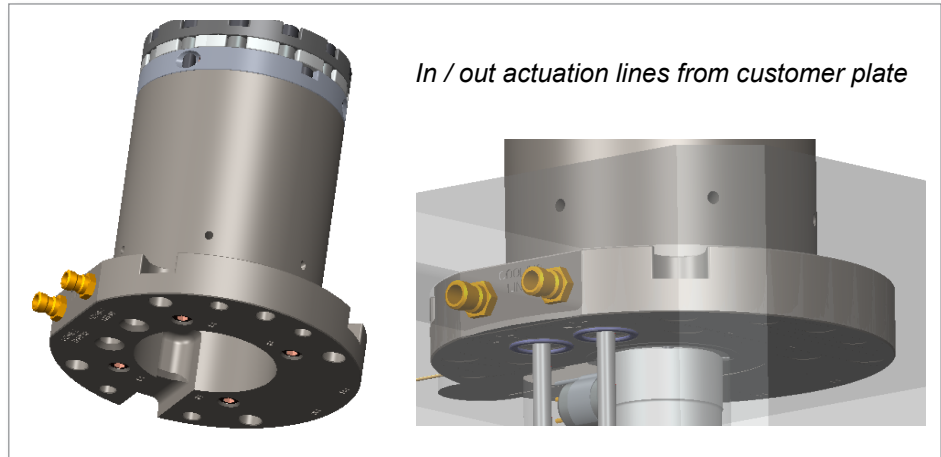

21. Install the termcon assembly, ground wire assembly and thermocouple assembly into the heated body.

22. Insert the end of the thermocouple completely into the mating hole and bend it into the thermocouple groove.

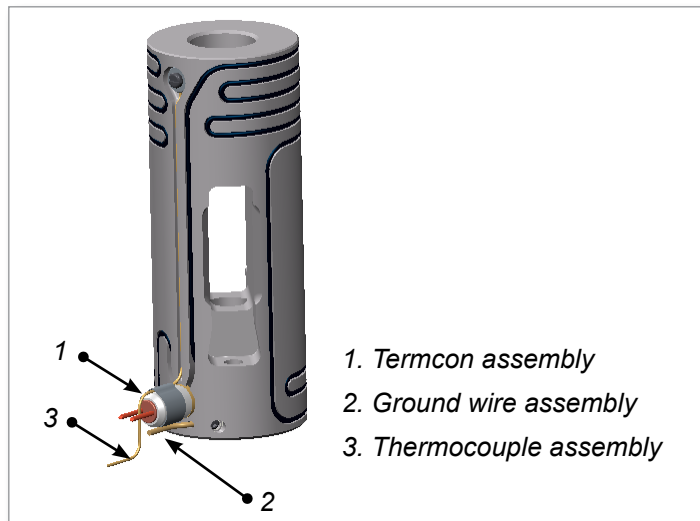

23. Use a box spanner and assemble the valve insert into the heated body with a torque of 54 Nm (40 lbf-ft).

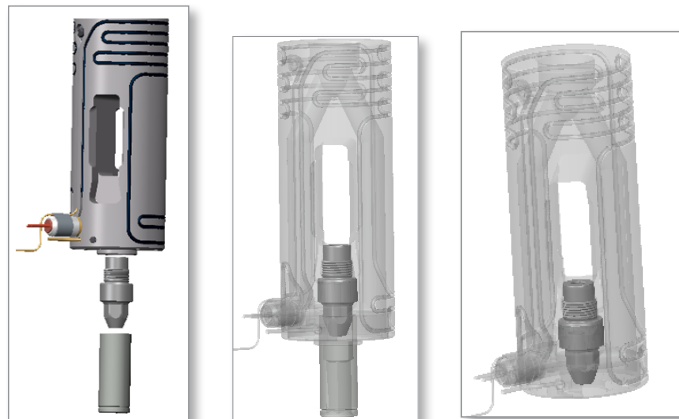

Accu-Line with Valve Insert Assembly - continued

24. Assemble the inlet tip into the heated body and torque to 68 Nm (50 lbf-ft).



25. Attach the gate seal and liner to nozzle. Attach nozzle thermocouple.

26. Assemble the adapter into the nozzle.

27. Insert the screws. For M5 screws, torque to 7 Nm (5 lbf-ft). For M8 screws torque to 20Nm (15 lbf-ft).



NOTE

Hecto nozzles do not need the screws to be installed in this procedure. Two screws will be installed with the heated body.

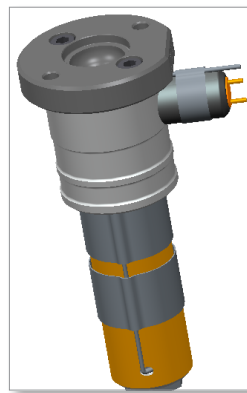
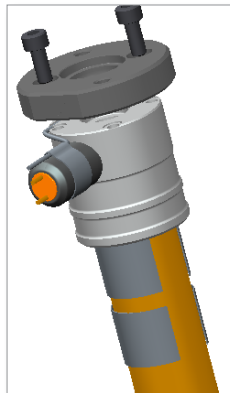

DECI nozzles only

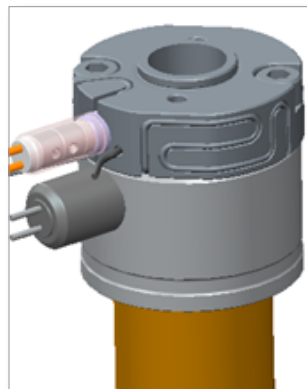
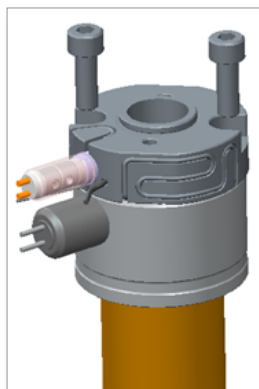

MEGA nozzles only

Accu-Line with Valve Insert Assembly - continued

28. Slide the valve pin into the nozzle assembly.

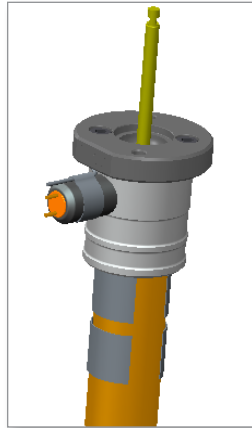

29. Install the heated body onto the nozzle assembly.

30. Insert the screws and torque to 14 Nm (10 lbf-ft).

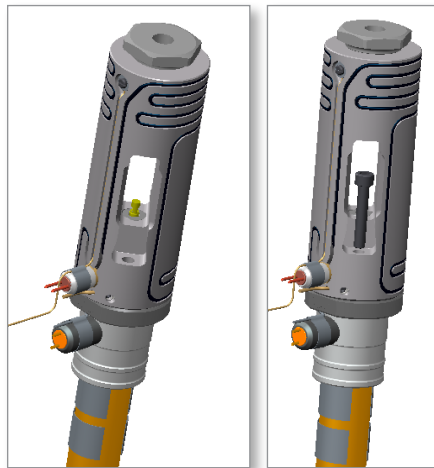

31. Slide the valve pin holder into the heated body slot and over the valve pin head.

32. Insert the valve pin head into the keyhole slot in the valve pin holder and slide the holder so that the pin head is located in the narrow portion of the slot.



Accu-Line with Valve Insert Assembly - continued

33. In cold condition, measure the N dimension in the heated body and the T dimension in the cylinder body.



IMPORTANT

Ensure that these two measurements are equal.



NOTE

Air gap will be determined by the flange depth in the mold plate.

Non Front Mounted Models:

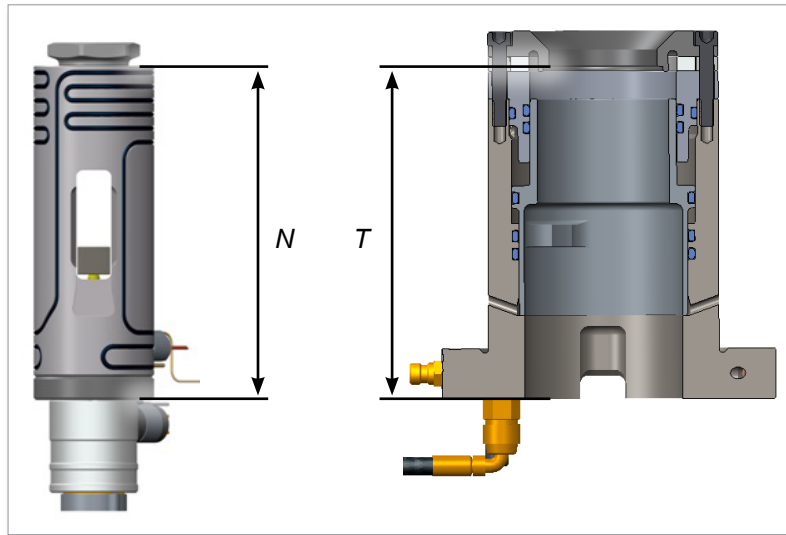

Front Mounted Models:

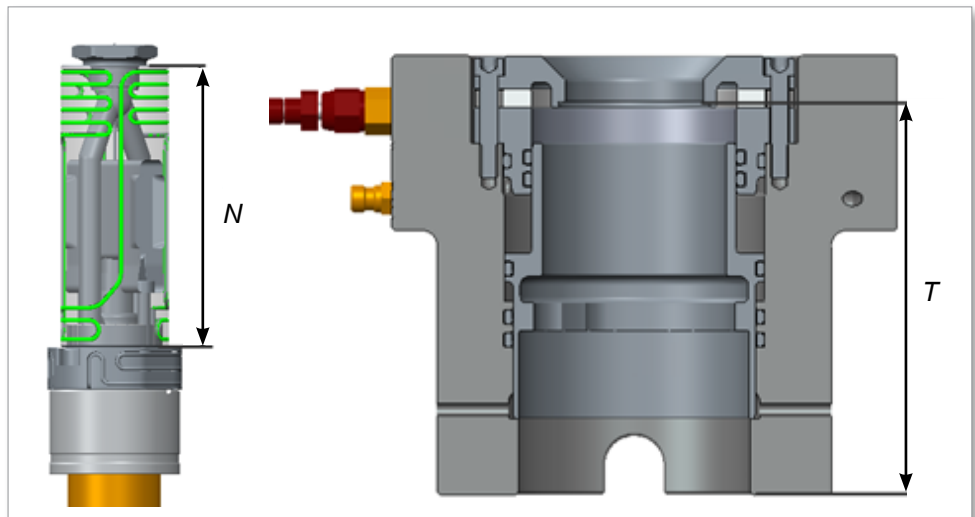

Accu-Line with Valve Insert Assembly - continued

34. Carefully place the nozzle assembly into the hydraulic unit.



NOTE

Ensure that the nozzle terminal end is correctly oriented.

Non Front Mounted Models:

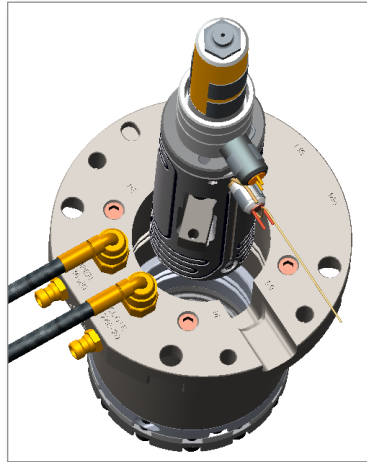

Front Mounted Models:

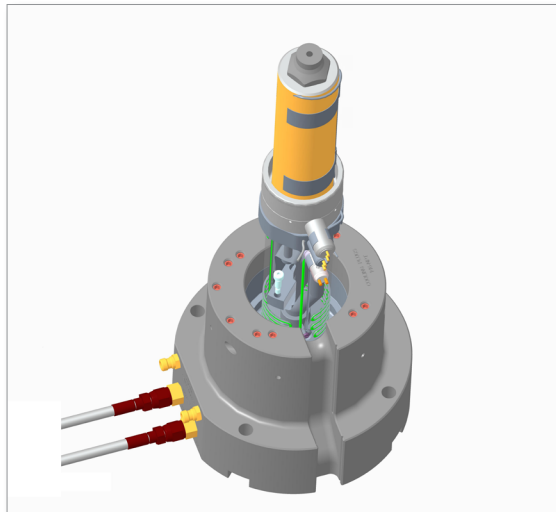

Accu-Line with Valve Insert Assembly - continued

35. Secure the valve pin holder to the piston with a shoulder head screw.
Torque to 3 Nm (2.2 lbf-ft).

Non Front Mounted Models:

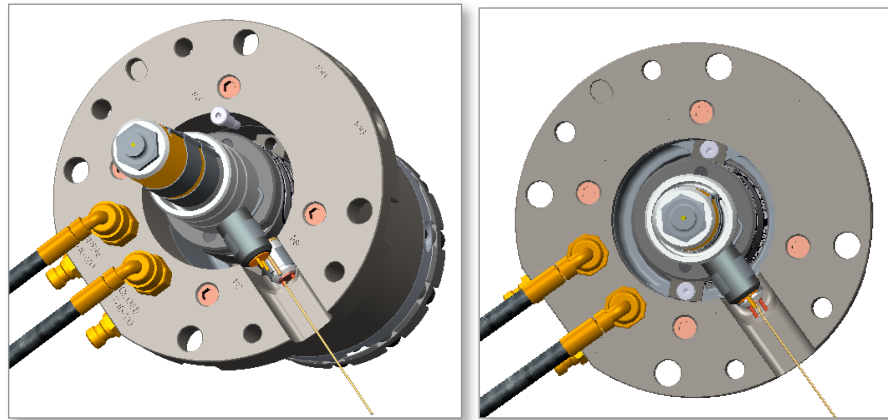

Front Mounted Models:

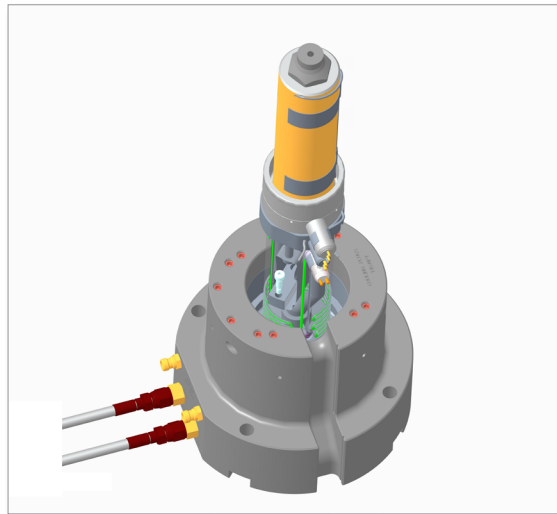

Accu-Line with Valve Insert Assembly - continued

36. Assemble the unit into the mold and verify the assembly. Check all the connections and actuations for accuracy.

Non Front Mounted Models:

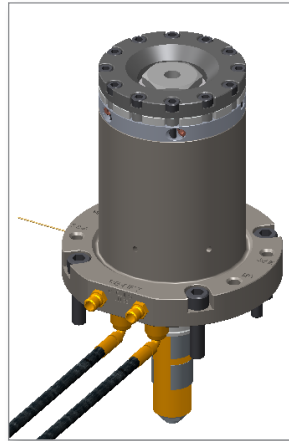

Front Mounted Models:

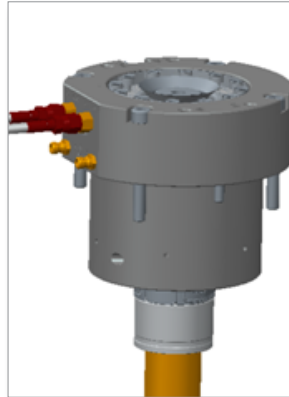

Front mounted Accu-Line™ models have built in wire channel cutouts for easy connection to the electrical box. See Figure 7-3.

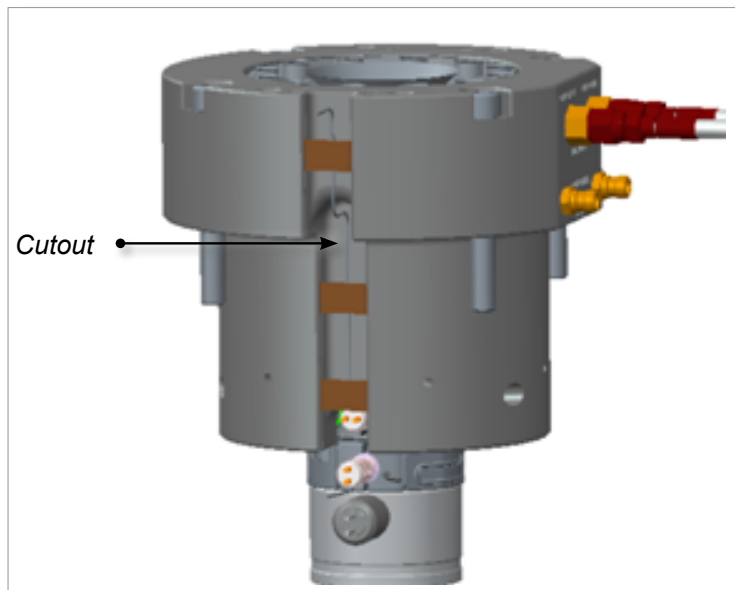

Figure 7-3 Cutout on front mounted models

Section 8 - Electrical Testing



WARNING

Ensure that you have fully read “Section 3 - Safety” before beginning electrical testing.

This section contains guidelines for electrical testing of your Mold-Masters Dura Plus Hot Runner system. The testing is based on the following European and North American standards:

- EN 60204-1 / DIN EN 60204-1 (IEC 60204-1, modified) Safety of machinery - electrical equipment of machines
- NFPA 79 Electrical Standard for Industrial Machinery

The standards themselves are the final authority for testing requirements (also any additional testing requirements from any national standards where the Hot Runner is in use).

8.1 Safety



WARNING

The user is responsible to ensure protection against shock by indirect contact, by protective earth conductors and automatic disconnection of supply. Mold-Masters components and systems are either equipped with a protective earth conductor or there is a connector for this purpose.

Before you carry out electrical work, make sure that the Hot Runner system is securely grounded. Turn the temperature control off and disconnect all electric wires coming from the mold. Failure to follow any of these steps may lead to serious injury or death.

Ensure that all wiring and connection work is performed by a qualified electrician according to DIN EN 60204-1 / NFPA79.

If performing work on a disassembled nozzle, it should only be connected to an electrical supply when the nozzle has been grounded or a safety isolating transformer is used.

Contact with a disassembled, heated, nozzle would cause serious burns. Use a sign in a visible location indicating “Danger: Do Not Touch”. Wear protective heat-resistant gloves and a full face shield over safety glasses.

8.2 Wiring Check

1. Check that each wire and thermocouple has a zone number.
2. Check that wires are organized and taped together by zone and plug.
3. Check all wires are secured in wire channels.
4. Connect all power leads and thermocouple wires to mold plugs.

8.3 Ground Shorts Test



CAUTION

Never apply full power to a heater if the insulation resistance reading is below 300 K Ω .

Always check the insulation resistance reader if the mold has not been in use for a number of weeks or months.



NOTE

Heater resistance above 500 K Ω is acceptable.

1. Use an ohm meter to check for continuity between the mold power connector ground pin (metal tabs on side) and the manifold steel. The ohm reading should be zero.
2. Measure the resistance between each pin of the mold power connector. See “Figure 8-1 Mold plug” and ground (mold base). The reading should be ∞ (infinity). Occasionally, the electric heaters accumulate moisture, which can reduce the resistance value to between 100 K Ω to 10 M Ω . The controller should be designed to remove this moisture during startup.
3. If necessary, remove excess moisture before placing the heater under full current.

8.4 Thermocouple Continuity Test

1. Measure the resistance between each pair of thermocouple wires on the mold’s thermocouple connector. See “Figure 8-1 Mold plug”.



NOTE

The resistance should be between 2.5 Ω and 25 Ω .

2. To verify alignment of the thermocouple in the heating element, turn on one zone after the other and check that the temperature responds accordingly if the set temperature is adjusted.

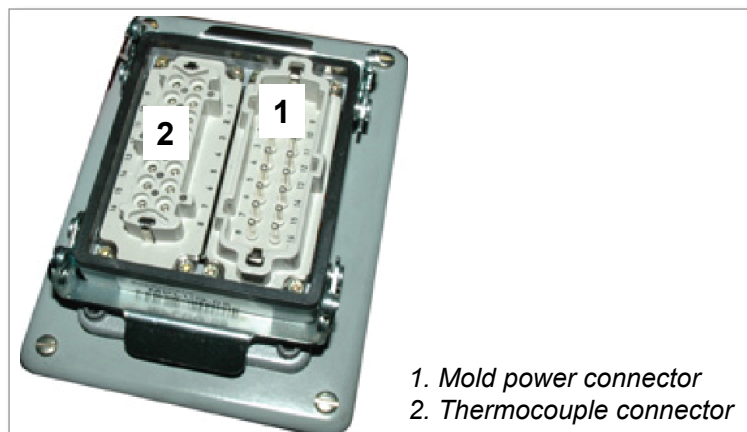

1. Mold power connector
2. Thermocouple connector

Figure 8-1 Mold plug

8.5 Pinch Point Test

1. If there is a suspected pinch point on the thermocouple, remove the thermocouple from the Hot Runner.
2. Connect a temperature control device to read the temperature.
3. Immerse the sheath of the thermocouple in boiling water to the point where the thermocouple reads the temperature.
4. A good thermocouple will show a temperature rise as soon as the tip of the thermocouple is immersed in water. If there is a pinch point in the thermocouple, there will be no change in the reading until the pinch point on the thermocouple is immersed in water.

8.6 Heater Continuity

Measure the resistance between each pair of heater power wires at the mold power connector.

Compare your reading with your General Assembly drawing.

Where:

$$R = \frac{V^2}{P}$$

R = resistance V = voltage P = power

8.7 Thermocouple Wiring Guidelines



CAUTION

Exceeding controller zone amperage will cause controller fuses to blow.

- Thermocouples are type “J” ungrounded and color-coded to ASA standards. White = “+” and Red = “-”
- The tip must not be truncated or squeezed and must touch the bottom of the bore in order to measure the correct temperature.
- Each heat source should have its own closed loop temperature control in order to achieve accurate control.
- If there are not enough control zones, heat sources that have the same wattage and affect the same environment may be grouped together.

8.8 Heating Test with a Temperature Controller



CAUTION

Never start the heating with more than 40% of power.

- Stay a minimum of five minutes at 212°F (100 °C) before increasing heat.
- Stay with the system and monitor the initial heating to minimize risk.

8.9 Retesting

Where a portion of the electrical equipment is changed or modified, that portion must be reverified and retested, as appropriate.

Section 9 - Installation



WARNING

Ensure that you have fully read “Section 3 - Safety” before installing the Dura Plus Hot Runner system.

The following section is a step-by-step guide to install the Mold-Masters Dura Plus Hot Runner into the existing manifold plate system or spacer block system.

9.1 Prior to Assembly



WARNING

Make sure the lifting eyebolt, lifting chain and crane are rated to adequately support the weight of the plate(s). Failure to do so can cause a serious injury.

Make sure the machine has been locked out and tagged out in accordance to the machine’s documented procedures.

Failure to do so may lead to serious injury or death.



CAUTION

Do not assemble / disassemble cavity plate with the valve pins forward. Valve pins must be retracted prior to cavity plate installation. Potential pinch point. Ensure that all wires are retained.



NOTE

Refer to the General Assembly drawings for instructions.

1. Unpack and clean the system as outlined in “Section 4 - Preparation”.

9.2 System Installation

9.2.1 Assembling a Water-Cooled Nozzle Jacket



NOTE

Your system may not include the water cooling nozzle jacket option. Refer to your General Assembly drawing for details.

1. Clean the insert-seating bore.
2. Install O-rings onto the water cooling nozzle jacket.
3. Insert water cooling nozzle jacket assembly into seating bore.
4. Fasten the water cooling nozzle jacket to the mold plate with the supplied button head cap screw and washer.

9.2.2 Install Sub-Manifold Assembly



CAUTION

Match drop numbers stamped on bridge during assembly.

1. Measure and confirm height as specified on General Assembly drawing.
2. Insert nozzle into seating bore or water cooling nozzle jacket, ensuring that the anti-rotation dowel is engaged in the slot.
3. Take care not to pinch the wires.
4. Remove any installation tools used.
5. Apply anti-seize compound to the four system screws and install.
6. Torque system screws in a crossing pattern, gradually increasing torque to specified value. Refer to the General Assembly drawing for torque values.
7. Measure and confirm the angled sub-manifold height as specified on the General Assembly drawing.
8. Repeat for each drop.

9.2.3 Install Manifold Locator and Anti-Rotation Dowel



CAUTION

Ensure sufficient gap between the dowel and the manifold slot top surface. Under no circumstances should they touch.



NOTE

Check the General Assembly drawing for information for your system.

1. For some systems, locators are supplied oversize and must be ground to the same level as the top of the nozzles. Remove the material from the bottom face of the locator (FACE Y). Please check the General Assembly drawing for exception notations.

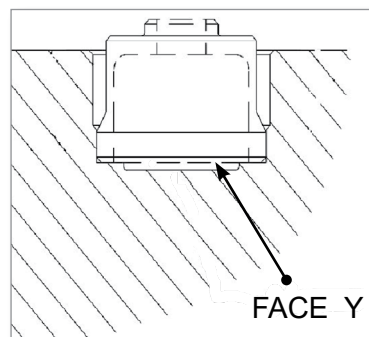
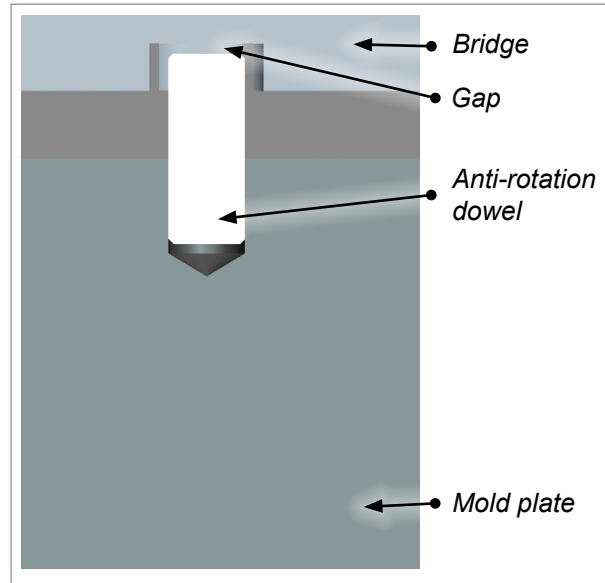

Figure 9-1 Locator surface

2. Using a depth micrometer, verify the dimensions of the manifold pocket to those specified on the print.
3. Apply die spotting blue the manifold locator into the bore to ensure proper seating.

Install Manifold Locator and Anti-Rotation Dowel - continued

4. Install the anti-rotation dowel into the mold.



9.2.4 Install Bridge Assembly



CAUTION

Match drop numbers stamped on bridge during assembly.



NOTE

Bridge mounting screws should be torqued 1/3 higher than specified on the General Assembly drawing.

1. Measure and confirm locator height as specified on General Assembly drawing.
2. Align bridge to sub-manifold and locate on manifold locator.
3. Take care not to pinch the wires.
4. Remove any installation tools used.
5. Apply anti-seize compound to the bridge screws.
6. Torque bridge screws in a crossing pattern gradually increasing torque to specified value. Refer to the General Assembly drawing for torque values.
7. Measure and confirm drop height as specified on General Assembly drawing.
8. Repeat for each drop.

9.2.5 Final Installation Steps

1. Connect the sub-manifold power wires to the bridge using quick connectors, if applicable. Ensure quick connectors are locked.
2. Connect all the plumbing (air and water hoses) to the sub-manifold unit.
3. Install screws to secure electrical and solenoid interface to exterior of mold base.
4. Install clamp plate.

Section 10 - Startup and Shutdown



WARNING

Ensure that you have fully read “Section 3 - Safety” before starting up or shutting down the Dura Plus Hot Runner system.

10.1 Pre-Startup



WARNING

Take appropriate safety precautions by assuming the system is pressurized and hot at all times.



CAUTION

Water must be turned on for Dura Plus actuation before turning on temperature controls. Actuator water temperature cannot exceed 29.4 °C (85 °F).

When running thermally sensitive materials, use a thermally stable material as recommended by the material supplier for the initial startup.

After the Dura Plus system is installed in the molding machine, make sure to bleed all the air out of the hydraulic lines, if applicable. Failure to do so could result in high gate vestige.

Check that the system is heated to processing temperature before actuating the valve pins. Failure to do so could cause damage to the valve pins.

The maximum operating temperature for Hot Runner systems is 400°C (750°F).

1. Install the mold into the molding machine.



NOTE

Ensure that the machine nozzle opening is the same size, or is **not more** than 1.0 mm (0.040 in.) smaller, than the melt entrance for the Hot Runner system.

2. Connect all water lines and test to ensure there are no leaks and that the required flow is achieved in all water circuits.
3. Connect all hydraulic / pneumatic lines, if applicable.
4. Connect all electrical components and monitor to ensure that all zones are receiving heat and all thermocouples are reacting appropriately.
5. Turn on the machine barrel and mold cooling system.
6. Prior to startup, ensure that the:
 - a) Dura Plus valve gate actuator water is on, if applicable
 - b) maximum inlet water temperature does not exceed 85°F (29.4°C)
 - c) machine barrel is up to processing temperature
 - d) mold cooling is on and at cooling temperature
7. If applicable, test the valve pin actuation, but only if the Hot Runner is at processing temperature. See **CAUTION** above.

10.2 Startup



WARNING

Take appropriate safety precautions by assuming the system is pressurized and hot at all times.

When the mold is open never inject material through Hot Runner system under high pressure.

Failure to do so can result in serious injury or death.

The correct startup procedure for your Hot Runner system depends on the type of system:

- Standard systems: see 10.2.1 Standard Hot Runner Systems on page 10-2
- Stack mold systems: see 10.3.2 Stack Mold System on page 10-4

10.2.1 Standard Hot Runner Systems



CAUTION

Failure to follow this procedure may result in leakage / damage occurring in the Hot Runner.



IMPORTANT

When running thermally sensitive materials, use a thermally stable material as recommended by the material supplier for the initial startup.

1. Heat up all Hot Runner manifolds and / or bridges and inlets (excluding the nozzles) to processing temperature.
2. Begin nozzle heating when the manifolds and / or bridges have come within 50°C of processing temperature.



IMPORTANT

Wait until ALL heating zones have reached processing temperature for 5 minutes before continuing.

For Hot Runner systems using heater plates, allow 10 minutes of soak time after the system reaches processing temperature.

3. Startup for empty Hot Runner system: extrude material through the Hot Runner system using 200 PSI (14 bar) of back pressure.
4. Startup for systems filled with material: purge intended shot size twice from the barrel prior to bringing the machine barrel forward to the Hot Runner interface.
5. Set injection time and pressure according to part size, gate size and material.

10.2.2 Stack Mold Systems



CAUTION

Failure to follow this procedure may result in leakage / damage occurring in the Hot Runner.



IMPORTANT

When running thermally sensitive materials, use a thermally stable material as recommended by the material supplier for the initial startup.

1. Heat up all Hot Runner manifolds, submanifolds, bridges and sub-bridges, and inlets (excluding the nozzles) to processing temperature.
2. After manifolds, submanifolds, bridges and sub-bridges reach setpoint, heat nozzles and spacers to 150°C (300°F).
3. Heat soak for 15 minutes.
4. Raise nozzle temperature to setpoint.
5. Heat soak for 20 minutes.

10.3 Shutdown

The correct shutdown procedure for your Hot Runner system depends on the type of system:

- Standard systems: see 10.3.1 Standard Hot Runner Systems on page 10-3
- Stack mold systems: see 10.3.2 Stack Mold System on page 10-4

10.3.1 Standard Hot Runner Systems



CAUTION

Failure to follow this procedure may result in leakage / damage occurring in the Hot Runner.



IMPORTANT

Thermally sensitive materials should be purged from the Hot Runner system prior to shutdown using a thermally stable material with a similar processing temperature.

1. Turn off all heat to the system.
2. Leave the mold cooling system ON, including valve actuator water, until the Hot Runner system temperature is within 100°F (37.7°C) of the mold temperature.

10.3.2 Stack Mold System

**CAUTION**

Failure to follow this procedure may result in leakage / damage occurring in the Hot Runner.

**IMPORTANT**

Thermally sensitive materials should be purged from the Hot Runner system prior to shutdown using a thermally stable material with a similar processing temperature.

1. Shutdown spacers, sub-bridges and bridges.
2. Reduce nozzle temperatures to 230°F (110°C).
3. Wait 20 minutes.
4. Shutdown manifolds, submanifolds, inlets and nozzles.

Section 11 - Maintenance



WARNING

Ensure that you have fully read “Section 3 - Safety” before doing maintenance procedures on the Dura Plus Hot Runner system.

This chapter is a guide to maintaining selective components.

Repairs that should be performed by Mold-Masters personnel are not included. If you need an item repaired that is not included in this section, please call Mold-Masters support.

11.1 Repair Kits and Crimping Tools



NOTE

Please contact your local Mold-Masters representative to ensure you have the correct repair kit and crimping tool. Available tools and lead wire replacement kits are shown below. See Section 2 - Global Support on page 2-1 for contact information.

Table 11-1 Crimping Tool Chart	
Product Name	Description
PUNCHHANDLE01	Ratchet tool for securing crimp to terminal end assemblies
CRIMPDIE01	4.0 mm Heater Element (Mates with CRIMPPUNCH01)
CRIMPPUNCH01	4.0 mm Heater Element (Mates with CRIMPDIE01)
CRIMPDIE02	2.5 - 3.0 mm Heater Element (Mates with CRIMPPUNCH02)
CRIMPPUNCH02	2.5 - 3.0 mm Heater Element (Mates with CRIMPDIE02)
CRIMPDIE03	1.8 - 2.0 mm Heater Element (Mates with CRIMPPUNCH03)
CRIMPPUNCH03	1.8 - 2.0 mm Heater Element (Mates with CRIMPDIE03)
CRIMPREMOVEB01	Bottom Crimp Removal Insert for shearing HE crimps (Mates with CRIMPREMOVET01)
CRIMPREMOVET01	Top Crimp Removal Insert for shearing HE crimps (Mates with CRIMPREMOVEB01)

11.2 Terminal End Removal



CAUTION

Care must be taken when removing the element sleeve to avoid damage to the ceramic sleeve or terminal nut.

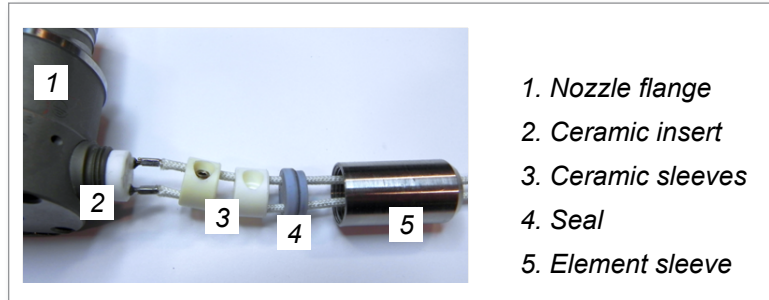
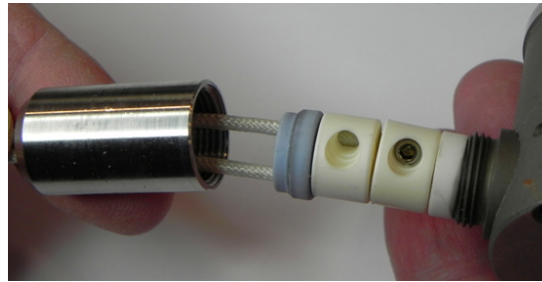

Figure 11-1 Nozzle terminal assembly

1. If the terminal end is covered with plastic, warm the terminal end prior to removing the element sleeve.
2. Grip the element sleeve at the threaded area and turn counter clockwise. If the wires rotate with the sleeve, damage may result.



3. Remove the seal.
4. Remove the set screw from the ceramic sleeve.



Terminal End Removal - continued

5. Remove the power leads.

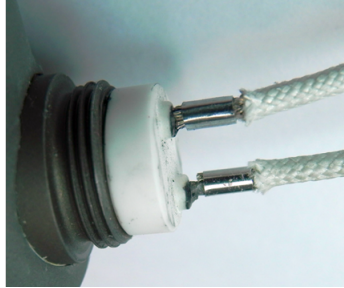
**11.3 Terminal Assembly****CAUTION**

Keep an eye on the silicon seal. It should not rotate with the sleeve during the assembly process or the wires may break.

1. Assemble the repair kit components.
2. Ensure the terminal end is clean.



3. Slide the element sleeve, silicon seal and ceramic insulator onto the wires.

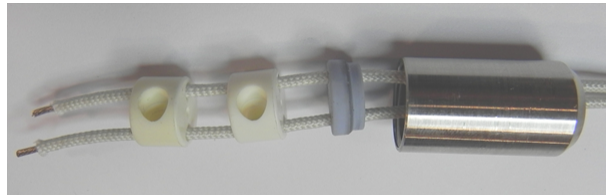

4. Slide crimps onto leads. Stranded wire should extend beyond the crimp.



Terminal Assembly - continued

5. Spread the wire strands and insert the lead wire onto the terminal posts.

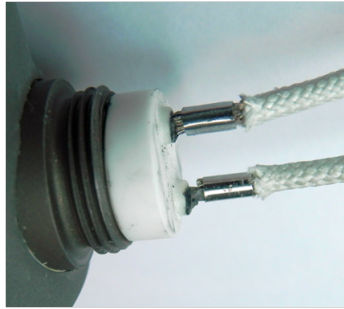

6. Grasp the crimp with the crimping tool, slide the crimp into position over the terminal post and crimp the connection.



7. Slide the ceramic insulators and silicon seal into place.

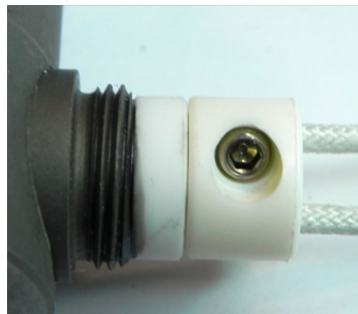

8. Complete the repair by screwing the element sleeves into position.



Terminal Assembly - continued

9. Slide the second ceramic insulator and silicone seal into place.

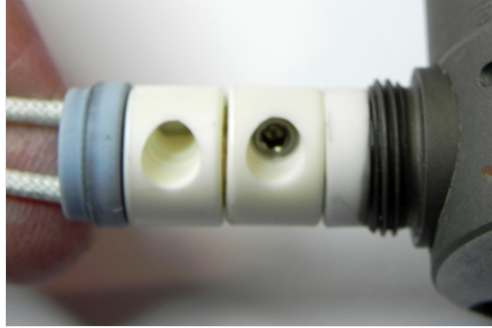

10. Complete the assembly by screwing the element sleeve into position.

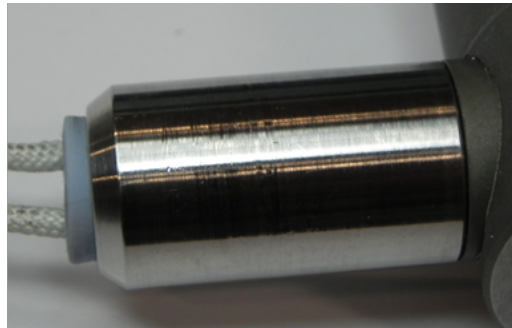
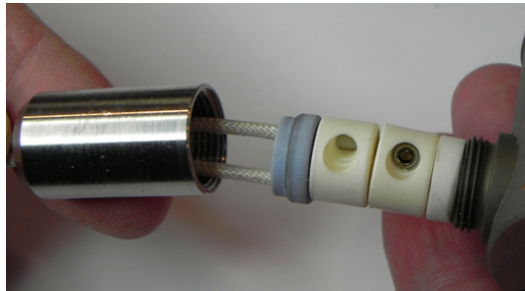

Figure 11-2 Nozzle terminal assembly

11.4 Heater Plate Power Lead Replacement

11.4.1 Removal

1. Remove the set screws.
2. Slide ceramic sleeve off.
3. Remove the power leads using crimp removal tool.

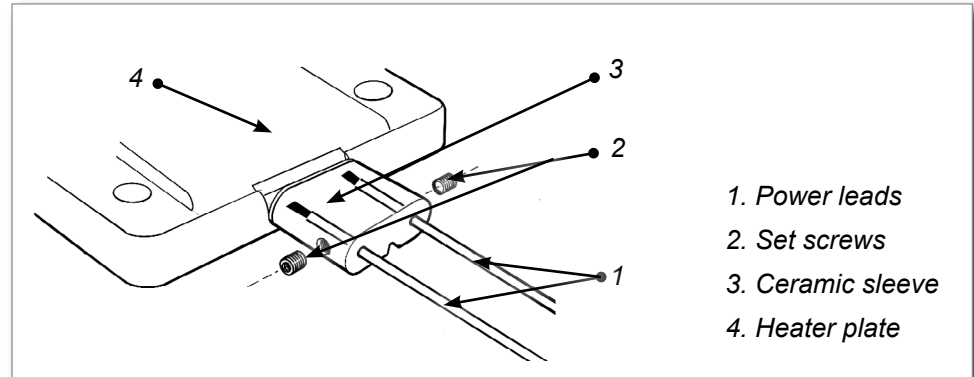

Figure 11-3 Terminal end assembly

11.4.2 Installation

1. Push the replacement leads into the holes in the ceramic sleeve.
2. Crimp the leads to the terminal ends.
3. Slide ceramic sleeve over the terminal end.
4. Tighten the set screws on the ceramic sleeve to secure the terminal assembly.

11.5 Gate Seal Maintenance

Reasons for gate seal maintenance:

- Tip damage
- Obstruction to melt flow
- Gate seal damage
- Tip wear

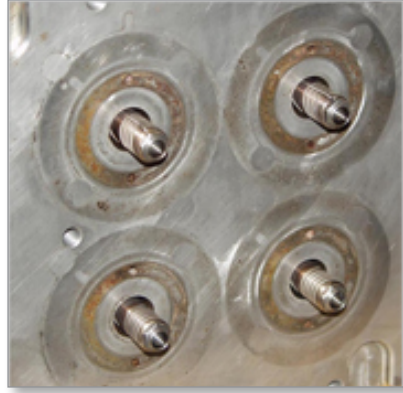

11.6 Multi-Cavity Systems

It is advisable to heat the system to ensure the temperature condition is met to remove the gate seals.



NOTE

Use the socket supplied in the Mold-Masters tool kit to loosen the gate seal.

It is recommended to use a temperature controller for this procedure. If a temperature controller is not available, contact your nearest Mold-Masters Service Department.

For gate seal installation and torquing procedures refer to “11.8 Gate Seal Replacement”.

11.7 Gate Seal Removal



WARNING

High temperature on the nozzle. Wear safety clothing such as heat resistant coat and heat resistant gloves.

Failure to do so may cause serious injury.



CAUTION

The terminal end is a sensitive area and can easily break if not handled to specifications.

Hot Runner systems must be within 40 °C (70 °F) of mold temperature before the cavity plate can be removed.



NOTE

If the cavity plate is easily removed you can access the nozzle seals while still in the system.

It is recommended the nozzle be removed from the system before removing the gate seal.

Use the socket supplied in the Mold-Masters tool kit to loosen the gate seal.

The following procedure applies to all gate seals, including carbide, with threads larger than an M6.

1. Apply penetrating lubricant to gate seal area.



2. Leave the nozzle in the mold or remove it to a vice and clamp carefully.
3. Using the temperature controller, heat the nozzle body until all residual plastic is melted from the gate area. If the nozzle is inside the mold, heat up the whole system and turn on the cooling or remove all O-rings.
4. While the nozzle is still hot, apply a loosening pressure to the gate using the socket to remove the seal.
5. Turn off the controller and wait for five minutes.

Gate Seal Removal - continued

6. Remove the gate seals.



11.8 Gate Seal Replacement



WARNING

Ensure nozzles have cooled to room temperature. Failure to do so may cause serious injury.

High temperature on the nozzle. Wear safety clothing such as heat resistant coat and heat resistant gloves. Failure to do so may cause serious injury.



CAUTION

It is critical that seal surface is perfectly clean. Failure to clean properly may result in nozzle and seal damage and leakage.

Any anti-seize compound that enters the internal runner must be removed to prevent contamination of melt.

Failure to torque the gate seals at processing temperatures may result in leakage.



CAUTION

Gate seals are torqued at ambient (room) temperature at Mold-Masters. Please torque each seal at processing temperature to the torque value specified to prevent material leakage from the gate seal.

1. Clean the nozzle, especially the thread and runner.
2. Clean all residual plastic from the threads and counter bore of the gate seal.

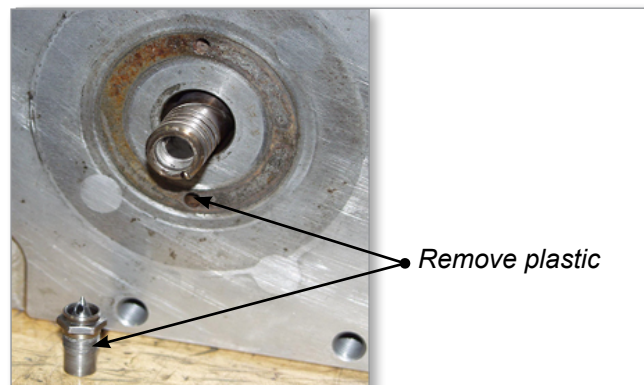

Figure 11-4 Cleaning locations

Gate Seal Replacement - continued

3. Check the bottom face of the nozzle counterbore for damage. If damaged, lap the bottom face of the nozzle in a circular fashion with a hardened tool and 300 grit lapping compound. If the nozzle counterbore is free of damage, proceed to step 5.



4. After lapping is complete, apply die spotting blue to the liner to the nozzle to ensure proper mating. If the liner is making good contact, clean the die-spotting blue compound off both faces.



5. Apply anti-seize compound (nickel based) to the gate seal threads ONLY. Make sure that the internal runner is clean and free from anti-seize compound.



6. Using a socket wrench, reinstall the gate seal being careful not to damage it.
7. Torque the gate seal to the appropriate value. Refer to "Gate Seal Torque Settings" on page 11-12.
8. Check that the seal has bottomed out, heat nozzle to process temperature and re-torque seal.

11.9 Checking Nozzle Tip Height

1. Correct nozzle tip height and nozzle reference point is found on the gate detail of the General Assembly drawing.
2. Assemble spacer blocks to same value as correct nozzle tip height.
3. Zero vernier to spacer blocks.



4. Move vernier to correct reference point on nozzle tip as indicated by the General Assembly drawing.



5. Check that nozzle height is within drawing specification.
6. Repeat for each nozzle.

11.10 Nozzle Thermocouple Removal



NOTE

Removing thermocouples will damage them and is not recommended unless replacing a damaged thermocouple with a replacement one.

1. Remove the thermocouple from the electrical box and wire channels.
2. Remove the nozzle from the manifold plate.
3. Remove the thermocouple retaining clips.
4. Remove the thermocouple.

11.11 Torque Settings

11.11.1 Gate Seal Torque Settings



CAUTION

Gate seals are torqued at ambient (room) temperature at Mold-Masters. Please torque each seal at processing temperature to the torque value specified to prevent material leakage from the gate seal.

Nozzle	Nm	ft-lb
Deci	34-38	25-28
Hecto	47-54	35-40
Mega	57-65	42-48

11.11.2 System and Plate Screw Torques



CAUTION

Bridge manifold mounting screws should be torqued 1/3 higher than specified on General Assembly drawings.

Quality and length of screws must be as specified on Mold-Masters General Assembly drawings.

Metric	Torque Setting	Imperial	Torque Setting
M5	7 Nm	#10-32	5 ft lbs
M6	14 Nm	1/4-20	10 ft lbs
M8	20 Nm	5/16-18	15 ft lbs
M10	40 Nm	3/8-16	30 ft lbs
M12	60 Nm	1/2-13	45 ft lbs
M16	145 Nm	5/8-11	107 ft lbs
M20	285 Nm	3/4-10	210 ft lbs

Metric	Torque Setting	Imperial	Torque Setting
M5	9 Nm / 6 ft lbs	#10-32	7 Nm / 5 ft lbs
M6	15 Nm / 11 ft lbs	1/4-20	16 Nm / 12 ft lbs
M8	36 Nm / 27 ft lbs	5/16-18	33 Nm / 24 ft lbs
M10	72 Nm / 53 ft lbs	3/8-16	59 Nm / 44 ft lbs
M12	125 Nm / 92 ft lbs	1/2-13	144 Nm / 106 ft lbs
M16	311 Nm / 229 ft lbs	5/8-11	287 Nm / 212 ft lbs
M20	606 Nm / 447 ft lbs	3/4-10	511 Nm / 377 ft lbs



NOTE

Torque sequence and step torquing:

It is recommended that system screws be torqued in a standard bolt pattern and that the specified torque is achieved in 3 steps (1/3, 2/3 and full torque).

Section 12 - Troubleshooting

Molding is a complicated process with many variables to consider. If you are having problems, take a step-by-step systematic approach to find a solution that optimizes the process.

Some basic rules for troubleshooting:

- Define the problem; what is observed is only a symptom of the underlying problem.
- Develop a method to isolate the problem.
- Test one item at a time to verify results.
- Monitor the final solution to verify that the problem has been solved. Repeat occurrences of the same symptom may indicate other problems.
- Document the solution so that a repeat occurrence can be solved quickly.
- Consult other resources to augment the troubleshooting information in the attached guide. One of the best resources may be your resin supplier.

To help in this process, we welcome you to reference Mold-Masters Troubleshooting Guide which offers general information related to common issues. This document can be found at <https://www.moldmasters.com/support/troubleshooting>. If you cannot find your issue within the documentation and continue to have problems, please contact your local Mold-Masters hot runner expert for assistance.

Section 13 - Glossary of Terms

Aspect Ratio: Ratio of total flow length to average wall thickness.

Back Pressure: The pressure applied to the plastic during screw recovery. By increasing back pressure, mixing and plasticating are improved; however, screw recovery rates are reduced.

Backplate: Inlet component to the Hot Runner manifold.

Barrel: The part of the molding press where resin is melted.

B-side: The mold half that mounts to the moving side of the injection molding press. Sometimes referred to as the core side of the mold or the cold half, the B-side has ejector pins to push the part out of the open mold. An analysis of the part geometry determines the optimal part orientation to ensure that it will remain on the B-side when the mold is opened.

Clamp Force: The force required to hold the mold shut so resin cannot escape during injection.

Contoured Pins: Ejector pins with the ends shaped to match a sloping surface on the part.

Core: A convex feature on either side of the mold that will enter an opposing cavity when the mold is closed. The void between the cavity and core is where the resin solidifies and forms the part. Often the B-side of a mold is referred to as the core side.

Core-cavity: The design of a mold where the A-side forms the outside of the part and the B-side forms the inside. The advantage to this approach is that the part will shrink onto the B-side so it can be ejected, and if the inside and outside are drafted with equal and opposite draft the wall thickness will be constant.

Cycle Time: The time it takes to make one part including the closing of the mold, the injection of the resin, the solidification of the part, the opening of the mold and the ejection of the part.

Cavity: The space inside a mold into which material is injected.

Clamp: The part of an injection molding machine incorporating the platens that provides the force necessary to hold the mold closed during injection of the molten resin and open the mold to eject the molded part.

Clamping Plate: A plate fitted to a mold and used to fasten the mold to a platen.

Clamping Pressure: The pressure applied to the mold to keep it closed during a cycle, usually expressed in tons.

Glossary of Terms - continued

Closed-loop Control: System for monitoring complete, injection molding-process conditions of temperature, pressure and time, and automatically making any changes required to keep part production within preset tolerances.

Cooling Channels: Channels located within the body of a mold through which a cooling medium is circulated to control the mold surface temperature.

Cushion: Extra material left in barrel during cycle to try and ensure that the part is packed out during the hold time.

Cycle: The complete sequence of operations in a process to complete one set of moldings. The cycle is taken at a point in the operation and ends when this point is again reached and moving platens of the clamp unit in the fully open position.

Cycle Time: The time required by an injection molding system to mold a part.

Dwell: A pause in the applied pressure to a mold during the injection cycle just before the mold is completely closed. This dwell allows any gases formed or present to escape from the molding material.

Ejector Pins: Pins that are pushed into a mold cavity from the rear as the mold opens to force the finished part out of the mold. Also called knockout pins.

Ejector Return Pins: Projections that push the ejector assembly back as the mold closes. Also called surface pins or return pins.

Ejector Rod: A bar that actuates the ejector assembly when the mold opens.

Family Mold: A multi-cavity mold where each of the cavities forms one of the component parts of an assembled finished part.

Fill: The packing of the cavity or cavities of the mold as required to give a complete part or parts that are free of flash.

Flow: A qualitative description of the fluidity of a plastic material during the process of molding. A measure of its moldability generally expressed as melt flow rate or melt index.

Gate: An orifice through which the melt enters the mold cavity.

Hot Tip Gate: An injection molding method that uses a heated gate on the A-side of the part to eliminate the creation of any runner or sprue. The gate vestige will be a small sharp bump that can be trimmed if necessary.

Hot Runner Mold: A mold in which the runners are insulated from the chilled cavities and are kept hot. Hot Runner molds make parts that have no scrap.

Injection: The process of forcing melted resin into a mold.

Glossary of Terms - continued

Injection Pressure: The pressure on the face of the injection screw or ram when injecting material into the mold, usually expressed in psi or bar.

Knockout Pins: A rod or device for knocking a finished part out of a mold.

L/D Ratio: A term used to help define an injection screw. This is the screw length-to-diameter ratio.

Manifolds: distribute melt from the inlet component to one or more sub-manifolds within a Hot Runner.

Melt Flow Rate: A measure of the molten viscosity of a polymer determined by the weight of polymer extruded through an orifice under specified conditions of pressure and temperature. Particular conditions are dependent upon the type of polymer being tested. MFR usually is reported in grams per 10 minutes. Melt flow rate defines the flow of a polypropylene resin. An extrusion weight of 2160 grams at 446°F (230°C) is used.

Melt Flow Index: Term that defines the melt flow rate of a polyethylene resin. An extrusion weight of 2160 grams at 310°F (190°C) is used.

Mold: A series of machined steel plates containing cavities into which plastic resin is injected to form a part.

Mold Frame: A series of steel plates which contain mold components, including cavities, cores, runner system, cooling system, ejection system, etc.

Mold-Temperature-Control Unit: Auxiliary equipment used to control Hot Runner temperature. Some units can both heat and cool the mold. Others, called chillers, only cool the mold.

Moving Platen: The platen of an injection molding machine that is moved by a hydraulic ram or mechanical toggle.

Multi-Cavity Mold: A mold having two or more impressions for forming finished items in one machine cycle.

Multi-Material Molding: The injection of two-or-more materials, in sequence, into a single mold during a single molding cycle. The injection molding machine is equipped with two-or-more plasticators. (See also co-injection)

Nest Plate: A retainer plate in the mold with a depressed area for cavity blocks.

Non-Fill: See short shot.

Non-Return Valve: Screw tip that allows for material to flow in one direction and then closes to prevent back flow during injection.

(Machine) Nozzle: The hollow-cored, metal nose screwed into the injection end of a plasticator. The nozzle matches the depression in the mold. This nozzle allows transfer of the melt from the plasticator to the runner system and cavities.

Glossary of Terms - continued

Packing: The filling of the mold cavity or cavities as full as possible without causing undue stress on the molds or causing flash to appear on the finished parts. Over- or under-packing results in less than optimum fill.

PET: Polyethylene terephthalate, a type of polyester and a leading recyclable plastic material.

Pinpoint Gate: A restricted gate of 0.030 in. or less in diameter, this gate is common on Hot Runner molds.

Platens: The mounting plates of a press on which the mold halves are attached.

Preform: A plastic test tube shaped part produced by injection molding systems in the first step of a two-stage injection molding and blow molding process used to produce PET bottles or containers. The preform is subsequently reheated and stretch blown through a blow molding process into the final container shape.

Pressure Disk: Manifold component designed to be compressed by thermal expansive forces to form part of the plastic sealing mechanism. Also helps to reduce thermal transfer to a minimum.

Process: The injection molding environment consisting of input variables such as temperature, pressure, injection rates and time that are controlled to fill the mold while optimizing the trade-offs between cosmetics and dimensional accuracy.

Ram: The forward motion of the screw in the barrel that forces the melt into the mold cavity.

Recovery Time: The length of time for the screw to rotate and create a shot.

Retainer Plate: The plate on which demountable pieces, such as mold cavities, ejector pins, guide pins and bushings are mounted during molding.

Ring Gate: Used on some cylindrical shapes. This gate encircles the core to permit the melt to first move around the core before filling the cavity.

Runner: The channel that connects the sprue with the gate for transferring the melt to the cavities.

Runnerless Molding: See Hot Runner mold.

Screw Travel: The distance the screw travels forward when filling the mold cavity.

Shear: The force between layers of resin as they slide against each other or the surface of the mold. The resulting friction causes some heating of the resin.

Short Shot: Failure to completely fill the part or cavities of the mold. Edges may appear melted.

Glossary of Terms - continued

Shot: The complete amount of melt injected during a molding cycle, including that which fills the runner system.

Shot Capacity: Generally based on polystyrene, this is the maximum weight of plastic that can be displaced or injected by a single injection stroke. Generally expressed as ounces of polystyrene.

Single-Cavity Mold: A mold having only one cavity and producing only one finished part per cycle.

Sprue Bushing: A hardened-steel insert in the mold that accepts the Screw nozzle and provides an opening for transferring the melt.

Sprue Gate: A passageway through which melt flows from the nozzle to the mold cavity.

Sprue: The feed opening provided in injection molding between the nozzle and cavity or runner system.

Stationary Platen: The large front plate of an injection molding press to which the front plate of the mold is secured. This platen does not move during normal operation.

Thermoplastic: A polymer which melts or flows when heated. Thermoplastic polymers are usually not highly cross-linked, and act much like molecular solids: low melting and boiling points, high ductile strength.

Thermoset: A polymer that does not melt when heated. Thermoset polymers “set” into a given shape when first made and afterwards do not flow or melt, but rather decompose upon heating. They are often highly cross-linked polymers, with properties similar to those of network covalent solids, i.e., hard and strong.

Valve Disk: Manifold component designed to be compressed by thermal expansive forces to form part of the plastic sealing mechanism. Its high tolerance bore allows the valve pin to shift through it without plastic leakage and part of it enters the melt stream and helps guide the plastic flow without stagnation.

Valve Gating: An injection molding method that uses a mechanical shut off to open and close the gate orifice.

Vent: A shallow channel or opening cut in the cavity to allow air or gases to escape as the melt fills the cavity.

Some glossary content © DRM Associates 2008 / © Protomold 1999-2009

Index

A

- Accu-Line...7-1
 - actuator assembly...7-1
 - with valve insert
 - assembling...7-2
 - actuator assembly...5-17
 - assembly...5-1

B

- bridge assembly...5-37
 - heated back plate
 - installing...5-37
 - inlet components
 - installing...5-37
 - inlet extension with
 - heater sleeves...5-38
 - installing...9-3
 - wiring channel...5-42

C

- ceramic sleeve...11-2
- checks
 - pre-assembly...5-2
- clamp force...13-1
- cleaning...4-3
- cooling channels...13-2
- crimping tool chart...11-1
- cycle time...13-1

D

- disposal...3-12
- document release details...1-1

E

- electrical box...5-48
- electrical testing...8-1
 - ground shorts test...8-2
 - heating test with temp. controller...8-4
 - pinch point test...8-3
 - retesting...8-4
 - thermocouple continuity test...8-2
 - wiring check...8-1
- external heater plates...5-31

F

- flexible heater
 - field replacement of...5-33

G

- gate seal
 - cleaning locations...11-9
 - removal...11-8
 - replacement...11-9
 - torque settings...11-12
- glossary of terms...13-1
- ground shorts test...8-2

H

- hazard areas...3-2
- heated back plate...5-38
 - installing...5-37
- heater continuity test...8-3
- heater-plate power lead
 - replacing...11-6
- heater plates
 - installing...5-31
- heating test with temp. controller...8-4
- hot tip gate...13-2
- hydraulic actuator
 - installing...5-25
- hydraulic system
 - installation...5-15

I

- installation...9-1
 - final steps...9-4
- intended use...1-1

M

- maintenance...11-1
 - gate seal...11-7
- manifold locator and anti-rotation dowel
 - installing...9-2
- manifold locator surface...9-2
- multi-cavity systems...11-7

N

- nozzle
 - attaching gate seals to...5-3
 - flange assembly...5-6
 - terminal assembly...11-2
- nozzle thermocouple
 - removing...11-12
- nozzle tip height
 - checking...11-11

P

- pinch point test...8-3
- pneumatic actuator
 - installing...5-17
- pneumatic system
 - installing...5-21
- pre-assembly checks...5-2
- pre-startup...10-1

Q

- quick connect
 - wiring channel...5-42

R

- release details
 - document...1-1
- repair kits...11-1
- returned goods policy...1-2
- rod wiper seal...5-18

S

- safety...3-1
 - hazards
 - Dura+...3-13
 - general...3-2
 - lockout...3-10
 - symbols...3-7
- screw lengths...4-2
- SeVG+ actuator...6-1
- shutdown
 - stack mold systems...10-4
 - standard hot runners...10-3
- solenoid valve wiring...5-48
- startup...10-1
 - stack mold systems...10-3
 - standard hot runners...10-2
- sub-manifold
 - for drop-in system...5-9
 - installing...9-2
 - power wiring...5-44
 - preparing to wire the bridge...5-45
 - solenoid valve wiring...5-48
 - thermocouple wiring...5-45
 - wiring...5-44
 - electrical box...5-48
 - wiring channel,
 - installing...5-46
- support...2-1

T

- terminal end
 - assembling...11-3
 - assembly...11-6
 - removing...11-2
- thermocouple
 - continuity test...8-2
 - installing...5-4
 - installing (Dura)...11-12
 - removal...11-12
 - wiring guidelines...8-3
- tools required...4-1
- torque settings
 - gate seal...11-12
 - plate screws...11-13
 - system screws...11-13
- tubular heater
 - installing...5-33
 - replacing...5-33
 - storage...5-33

U

- unpacking...4-2

V

- valve disk
 - installing...5-9
 - with nozzle heater sleeves
 - installing...5-12

W

- warranty...1-2
- water-cooled gate insert
 - installing...9-1
- water-cooled nozzle jacket
 - assembling...9-1
- wiring
 - channel...5-42
 - components...5-42
 - check...3-8, 8-1
 - solenoid valve...5-48



Scan the QR code for our global contacts:

