

Fusion® G3 series

User Manual

version 2



Contents

- Section 1 - Introduction1-1**
 - 1.1 Intended Use 1-1
 - 1.2 Documentation 1-1
 - 1.3 Document Release Details 1-1
 - 1.4 Warranty 1-1
 - 1.5 Returned Goods Policy..... 1-2
 - 1.6 Movement or Resale of Mold-Masters Products or Systems 1-2
 - 1.7 Copyright 1-2
 - 1.8 Units of Measure and Conversion Factors 1-3

- Section 2 - Global Support2-1**
 - 2.1 Worldwide Locations2-1

- Section 3 - Safety.....3-1**
 - 3.1 Operator Training and Safety3-1
 - 3.2 Safety Hazards3-2
 - 3.3 Operational Hazards.....3-5
 - 3.4 General Safety Symbols.....3-7
 - 3.5 Wiring Check3-8
 - 3.6 Lockout Safety.....3-9
 - 3.6.1 Electrical Lockout.....3-10
 - 3.6.2 Energy Forms and Lockout Guidelines.....3-11
 - 3.7 Disposal.....3-12
 - 3.8 Fusion-Series G3 Safety Hazards3-13

- Section 4 - Preparation4-1**
 - 4.1 Tools Required.....4-1
 - 4.2 Screw Lengths.....4-1
 - 4.3 Unpacking.....4-2
 - 4.4 Cleaning4-2
 - 4.5 Hydraulic Actuator4-3
 - 4.5.1 Adjust the Hydraulic Actuator Stroke (Optional).....4-8
 - 4.5.2 Adjust the Valve Pin Position (Optional)4-9
 - 4.6 Pneumatic Actuator4-10
 - 4.6.1 Adjust the Pneumatic Actuator Stroke (Optional).....4-15
 - 4.6.2 Adjust the Valve Pin Position (Optional)4-15
 - 4.7 Waterless Hydraulic Actuator.....4-16
 - 4.7.1 Assemble the Piston4-17
 - 4.7.2 Adjust the Valve Pin Length (Optional)4-19
 - 4.7.3 Assemble the Cylinder Body.....4-20
 - 4.7.4 Assemble the Cylinder4-22
 - 4.7.5 Assemble the Anti-Rotation Waterless Hydraulic Actuator4-23
 - 4.8 Waterless Pneumatic Actuator.....4-24
 - 4.8.1 Assemble the Piston4-25
 - 4.8.2 Adjust the Valve Pin Length (Optional)4-26
 - 4.8.3 Assemble the Cylinder Body.....4-27

4.8.4 Assemble the Cylinder	4-31
4.9 Assemble the Anti-Rotation Piston of the Ø63 mm Assembly	4-32
4.10 Assemble the Anti-Rotation Piston for the Ø80 mm Assembly	4-35
4.11 Assemble the Cylinder for the Ø63 mm and Ø80 mm Anti-Rotation Waterless Assemblies.....	4-38

Section 5 - Assembly5-1

5.1 Typical Fusion-Series Systems	5-1
5.1.1 Fusion-Series G3 Drop-In System.....	5-2
5.1.2 Fusion Series Lite System	5-2
5.2 Gate Seal Finishing	5-3
5.2.1 Hot Valve / Hot Sprue / F Type	5-3
5.3 Re-torque at Process Temperature	5-4
5.4 Check Nozzle Core to Manifold Fit.....	5-4
5.5 Assemble Nozzle to Manifold	5-6
5.6 Nozzle Assembly for Systems with Protective Sleeves	5-7
5.7 Nozzle Assembly for Systems without Protective Sleeves	5-12
5.8 Gate Seal and Nozzle Assembly	5-15
5.8.1 Check Gate Seal to Nozzle Fit.....	5-15
5.8.2 Install Gate Seal on Nozzle	5-16
5.9 Install Manifold Locator.....	5-17
5.10 Install Support Bushings.....	5-17
5.11 Install Manifold Thermocouple	5-19
5.12 Install Inlet with Flange	5-20
5.12.1 Install Inlet Thermocouple.....	5-22
5.12.2 Install Inlet Extension Tip.....	5-23
5.13 Install Inlet Extension without Flange	5-25
5.13.1 Check Inlet Extension Coredel to Manifold Fit.....	5-25
5.13.2 Install Nozzle Heaters and Sleeves	5-25
5.13.3 Install Inlet Thermocouple.....	5-25
5.13.4 Install Inlet Extension Tip.....	5-25
5.14 Install the Valve Insert or Valve Disk (VD)	5-26
5.14.1 Install the Valve Insert (Valve Insert Design)	5-26
5.14.2 Install the Valve Disk (Valve Disk Design)	5-27
5.15 Install the Cylinder on the Manifold	5-29
5.16 Tapered Valve Pins.....	5-31
5.16.1 Find the Current Lap.....	5-31
5.16.2 Hone a Tapered Valve Pin	5-32
5.16.3 Lap a Tapered Valve Pin.....	5-32
5.16.4 Clean the Valve Pin and Runner.....	5-34
5.16.5 Calculate the Preload of a Valve Pin (Timing the valve pin)	5-36
5.17 Waterless Hydraulic and Pneumatic Actuators.....	5-38
5.18 Install the Wire Armor on the Manifold.....	5-42
5.18.1 Install the Wiring	5-43
5.18.2 Electrical Routing into Electrical Box	5-43
5.18.3 Solenoid Valve Wiring.....	5-44
5.18.4 Plumbing Cylinders.....	5-45
5.19 Connect the Solenoid Valve Bank	5-47
5.19.1 Hydraulic Valvebank Connection	5-47
5.19.2 Pneumatic Valve Bank Connection.....	5-48
5.20 Install Hydraulic Flow Control Valve	5-49

5.21 Single Nozzle Hot Runner	5-51
5.21.1 Assemble the Nozzle	5-51
5.21.2 Install the Nozzle in the Back Plate	5-52
5.21.3 Assemble the Heater Sleeve	5-53
5.21.4 Assemble the heater sleeve and nozzle	5-53
5.21.5 Install the Nozzle in the Plate	5-55
Section 6 - SeVG Plus Actuator	6-1
Section 7 - Electrical Testing	7-1
7.1 Safety	7-1
7.2 Electrical Wiring Check.....	7-1
7.3 Electrical Safety Testing	7-2
7.3.1 Verify Equipment to its Technical Documentation.....	7-2
7.3.2 Insulation Resistance Test.....	7-2
7.3.3 Verification of Conditions for Protection by Automatic Disconnection of Supply 7-2	
7.3.4 Verification of Continuity of Protective Bonding Circuit.....	7-2
7.3.5 Verification of Fault Loop Impedance	7-3
7.4 Thermocouple Continuity Test.....	7-3
7.5 Pinch Point Test.....	7-3
7.6 Heating Element Check.....	7-4
7.7 Thermocouple Wiring Guidelines	7-4
7.8 Functional Test with a Temperature Controller	7-4
7.9 Retesting	7-4
Section 8 - Installation	8-1
8.1 Unpacking.....	8-1
8.2 Pre-Installation.....	8-2
8.3 Install Manifold Locator Dowel.....	8-2
8.4 System Installation	8-3
8.5 System Test	8-5
Section 9 - Startup and Shutdown	9-1
9.1 Pre-Startup	9-1
9.2 Startup	9-2
9.2.1 Shutdown.....	9-3
Section 10 - Color Change.....	10-1
10.1 Introduction.....	10-1
10.2 Color Change for a Hot Tip / Sprue System	10-1
10.3 Color Change for a Valve Gate System.....	10-2
10.4 Locating a Source of Contamination	10-2
Section 11 - Maintenance.....	11-1
11.1 Recommended Torque Settings.....	11-1
11.2 Tubular Heater	11-3
11.2.1 Storing.....	11-3
11.2.2 Removing a Heater Element.....	11-3

- 11.2.3 Installing a New Heater Element..... 11-4
- 11.2.4 Starting up a New Heater..... 11-6
- 11.3 Solenoid Valve Bank 11-6
 - 11.3.1 Hydraulic Solenoid Valve Bank 11-7
 - 11.3.2 Components of a Hydraulic Solenoid Valve Bank..... 11-7
 - 11.3.3 Pneumatic Solenoid Valve Bank 11-10
 - 11.3.4 Components of a Pneumatic Solenoid Valve Bank..... 11-10
- 11.4 Hydraulic Hoses, Fittings, and Seals 11-13
 - 11.4.1 Specifications 11-13
 - 11.4.2 Hose Failure..... 11-13
 - 11.4.3 Maintenance Schedule 11-14
 - 11.4.4 Maintaining and Replacing Hoses, Fittings, and Seals 11-14
- 11.5 Recommended Spare Parts 11-16
- 11.6 Extracting a Headless Valve Pin 11-17

Section 12 - Troubleshooting 12-1

- 12.1 Introduction 12-1
- 12.2 Moisture Related Issues 12-2
 - 12.2.1 Resin Moisture Contamination..... 12-2
 - 12.2.2 Resin Drying Issues..... 12-2
 - 12.2.3 Importance of Pre-Drying Resin 12-2
- 12.3 Pre-Molding Precautions 12-3
- 12.4 Establishing Root Cause 12-4
 - 12.4.1 Fault Identification..... 12-4
- 12.5 Troubleshooting Typical Problems..... 12-5
 - 12.5.1 Dark Specks 12-5
 - 12.5.2 Blisters or Bubbles..... 12-6
 - 12.5.3 Flow Marks 12-7
 - 12.5.4 Burn Marks 12-8
 - 12.5.5 Delaminating Parts 12-9
 - 12.5.6 Dimensional Irregularities 12-10
 - 12.5.7 Discolored Parts 12-11
 - 12.5.8 Flash 12-12
 - 12.5.9 Jetting 12-13
 - 12.5.10 Pitted Parts 12-14
 - 12.5.11 Rough Surface 12-15
 - 12.5.12 Parts Sticking to Cavity..... 12-16
 - 12.5.13 Parts Sticking to Core 12-17
 - 12.5.14 Short Parts..... 12-18
 - 12.5.15 Sinks or Voids 12-19
 - 12.5.16 Splay 12-20
 - 12.5.17 Streaks..... 12-21
 - 12.5.18 Stringing..... 12-22
 - 12.5.19 Warped Parts..... 12-23
 - 12.5.20 Weld Lines 12-24

Index I

Section 1 - Introduction

The purpose of this manual is to assist users in the integration, operation and maintenance of *Mold-Masters* systems. This manual is designed to cover most system configurations. If you need additional information specific to your system, or information in another language, please contact your representative or a *Mold-Masters* office.

1.1 Intended Use

Fusion Series systems have been built to process thermoplastic material at the required temperature for injection molding and must not be used for any other purpose.

This manual is written for use by skilled persons who are familiar with injection molding machinery and their terminology. Operators should be familiar with plastic injection molding machines and the controls of such equipment. Maintenance persons should have sufficient understanding of electrical safety to appreciate the dangers of 3-phase supplies. They should know how to take appropriate measures to avoid any danger from electrical supplies.

1.2 Documentation

This manual is part of the documentation package for your order and should be referenced along with the following documents included in the package:

- The Bill of Materials (BOM). Together with the General Assembly drawing, the Bill of Materials should be referenced when ordering spare parts.
- General Assembly drawing used to integrate your Hot Runner system into the mold.
- Hot Half drawing used to integrate Hot Half to cavity plate.
- CE declaration of conformity and declaration of incorporation (EU only)



NOTE

This manual should also be used in conjunction with other relevant manuals; e.g., Mold Machine Manual and Controller Manual.

1.3 Document Release Details

Table 1-1 Release Details		
Document Number	Release Date	Version
UM--FSG3--ENG--01	September 2023	01
UM--FSG3--ENG--01-1	November 2023	01-1
UM--FSG3--ENG--01-2	August 2024	01-2
UM--FSG3--ENG--01-3	July 2025	01-3
UM--FSG3--ENG--02	July 2026	02

1.4 Warranty

For current warranty information please refer to the documents available from the website www.moldmasters.com/support/warranty or contact your Mold-Masters representative.

1.5 Returned Goods Policy

Please do not return any parts to Mold-Masters without pre-authorization and a return authorization number supplied by Mold-Masters.

Our policy is one of continuous improvement and we reserve the right to alter product specifications at any time without giving notice.

1.6 Movement or Resale of Mold-Masters Products or Systems

This documentation is intended for use in the country of destination for which the product or system was purchased.

Mold-Masters takes no responsibility for documentation of products or systems if they are relocated or resold outside the intended country of destination, as stated on the accompanying invoice and/or waybill.

1.7 Copyright

© 2026 Mold-Masters (2007) Limited. All Rights Reserved. *Mold-Masters*[®] and the *Mold-Masters* logo are trademarks of Mold-Masters.

1.8 Units of Measure and Conversion Factors



NOTE

The dimensions given in this manual are from original manufacturing drawings.

All values in this manual are in S.I. units or subdivisions of these units. Imperial units are given in parenthesis immediately after the S.I. units.

Table 1-2 Units of Measure and Conversion Factors		
Unit	Abbreviation	Conversion Value
bar	Bar	14.5 psi
in.	Inch	25.4 mm
kg	Kilogram	2.205 lb
kPa	Kilopascal	0.145 psi
lb	Pound	0.4536 kg
lbf	Pound force	4.448 N
lbf.in.	Pound force inch	0.113 Nm
min	Minute	
mm	Millimeter	0.03937 in.
mΩ	Milliohm	
N	Newton	0.2248 lbf
Nm	Newton meter	8.851 lbf.in.
psi	Pound per square inch	0.069 bar
psi	Pound per square inch	6.895 kPa
rpm	Revolutions per minute	
s	Second	
°	Degree	
°C	Degree Celsius	0.556 (°F -32)
°F	Degree Fahrenheit	1.8 °C +32

Section 2 - Global Support

2.1 Worldwide Locations

To find your nearest Mold-Masters office for sales or service support, please visit www.moldmasters.com/location-map or scan this QR code:



Section 3 - Safety

3.1 Operator Training and Safety

Please be aware that the safety information provided by *Mold-Masters* does not absolve the integrator and employer from understanding and following international and local standards for safety of machinery. It is the responsibility of the end integrator to integrate the final system, provide necessary e-stop connections, safety interlocks and guarding, to select the appropriate electrical cable for the region of use and to ensure compliance with all relevant standards.

It is the responsibility of the employer to:

- Properly train and instruct its personnel in the safe operation of equipment, including the use of all the safety devices.
- Provide its personnel with all necessary protective clothing, including such items as a face shield and heat resistant gloves.
- Ensure the original and continuing competence of personnel caring for, setting up, inspecting and maintaining injection molding equipment.
- Establish and follow a program of periodic and regular inspections of injection molding equipment to ensure it is in safe operating condition and proper adjustment.
- Ensure that no modifications, repairs, or rebuild of portions are made to the equipment that reduces the level of safety existing at time of manufacture or remanufacture.

3.2 Safety Hazards



WARNING

Also refer to all machine manuals and local regulations and codes for safety information.

The following safety hazards are most commonly associated with plastic injection molding equipment (see European Standard EN201 or American Standard ANSI/SPI B151.1).

Refer to the illustration of hazard areas below when reading the Safety Hazards Table 3-1 on page 3-3.

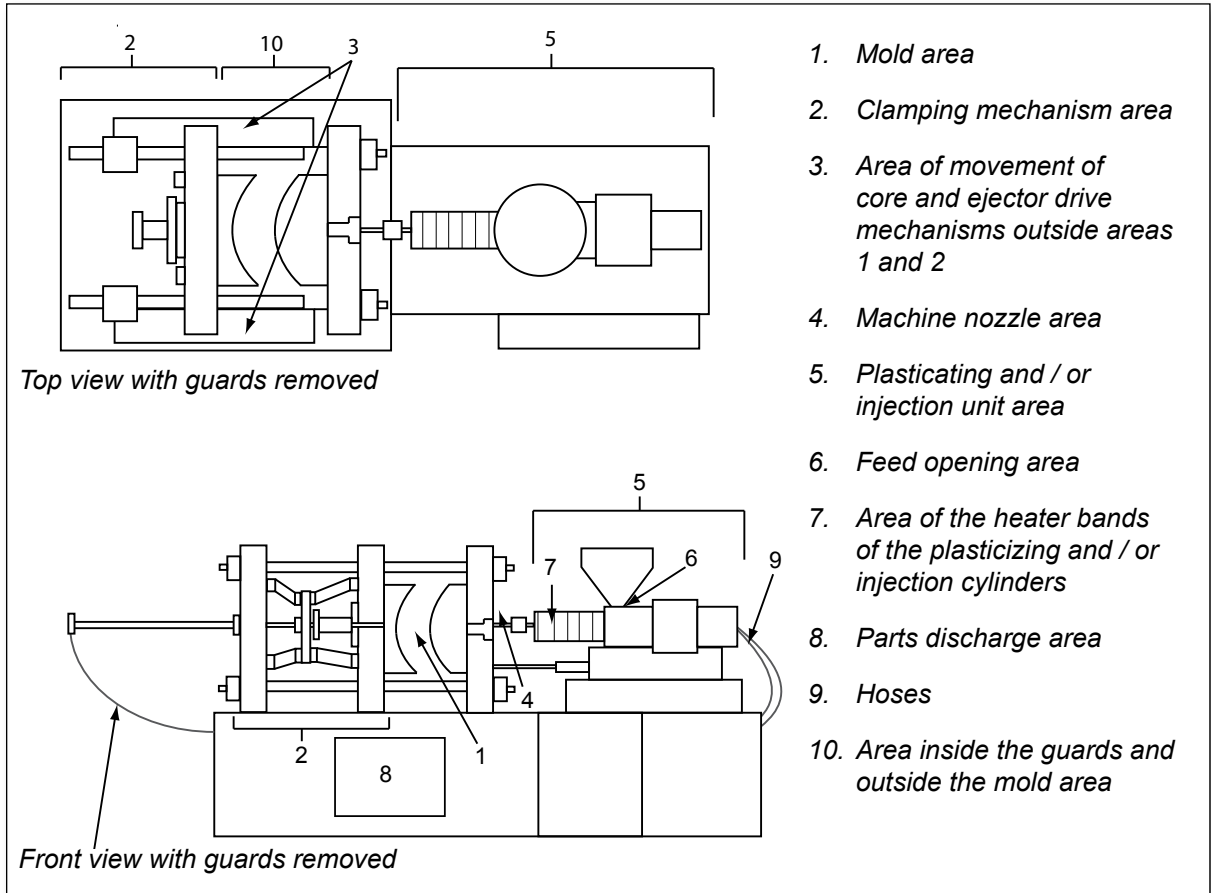

Figure 3-1 Injection molding machine hazard areas

Safety Hazards - continued

Table 3-1 Safety Hazards	
Hazard Area	Potential Hazards
<p>Mold Area Area between the platens. See Figure 3-1 area 1</p>	<p>Mechanical Hazards Crushing and / or shearing and/or impact hazards caused by:</p> <ul style="list-style-type: none"> • Movement of the platen. • Movements of the injection barrel(s) into the mold area. • Movements of cores and ejectors and their drive mechanisms. • Tie bar motion. <p>Thermal Hazards Burns and / or scalds due to operating temperature of:</p> <ul style="list-style-type: none"> • The mold heating elements. • Plasticized material released from / through the mold.
<p>Clamping Mechanism Area See Figure 3-1 area 2</p>	<p>Mechanical Hazards Crushing and/or shearing and / or impact hazards caused by:</p> <ul style="list-style-type: none"> • Movement of the platen. • Movement of the drive mechanism of the platen. • Movement of the core and ejector drive mechanism.
<p>Movement of Drive Mechanisms Outside the Mold Area and Outside the Clamping Mechanism Area See Figure 3-1 area 3</p>	<p>Mechanical Hazards Mechanical hazards of crushing, shearing and / or impact caused by the movements of:</p> <ul style="list-style-type: none"> • Core and ejector drive mechanisms.
<p>Nozzle Area The nozzle area is the area between the barrel and the sprue bushing. See Figure 3-1 area 4</p>	<p>Mechanical Hazards Crushing, shearing hazards, and / or impact hazards caused by:</p> <ul style="list-style-type: none"> • Forward movement of the plasticizing and / or injection unit including nozzle. • Movements of parts of-the power operated nozzle shutoff and their drives. • Over pressurization in the nozzle <p>Thermal Hazards Burns and or scalds due to operating temperature of: The nozzle. Plasticized material discharging from the nozzle.</p>
<p>Plasticizing and / or Injection Unit Area Area from the adapter / barrel head / end cap to the extruder motor above the sled including the carriage cylinders. See Figure 3-1 area 5</p>	<p>Mechanical Hazards Crushing, shearing and / or drawn-into hazards caused by:</p> <ul style="list-style-type: none"> • Unintentional gravity movements e.g. for machines with plasticizing and / or injection unit positioned above the mold area. • The movements of the screw and / or the injection plunger in the cylinder accessible through the feed opening. • Movement of the carriage unit. <p>Thermal Hazards Burns and or scalds due to operating temperature of:</p> <ul style="list-style-type: none"> • The plasticizing and / or injection unit. • The heating elements e.g. heater bands. • The plasticized material and / or vapors discharging from the vent opening, feed throat or hopper. <p>Mechanical and / or Thermal Hazard Hazards due to reduction in mechanical strength of the plasticizing and / or injection cylinder due to overheating.</p>
<p>Feed Opening See Figure 3-1 area 6</p>	<p>Pinching and crushing between injection screw movement and housing.</p>

Safety Hazards - continued

Table 3-1 Safety Hazards	
Hazard Area	Potential Hazards
Area of the Heater Bands of the Plasticizing and / or Injection Cylinders See Figure 3-1 area 7	Burns and / or scalds due to operating temperature of: <ul style="list-style-type: none"> • The plasticizing and / or injection unit. • The heating elements e.g. heater bands. • The plasticized material and / or vapors discharging from the vent opening, feed throat or hopper.
Parts Discharge Area See Figure 3-1 area 8	Mechanical Hazards Accessible Through the Discharge Area Crushing, shearing and / or impact hazards caused by: <ul style="list-style-type: none"> • Closing movement of the platen. • Movements of cores and ejectors and their drive mechanisms. Thermal Hazards Accessible Through the Discharge Area Burns and or scalds due to operating temperature of: <ul style="list-style-type: none"> • The mold. • Heating elements of the mold. • Plasticized material released from / through the mold.
Hoses See Figure 3-1 area 9	<ul style="list-style-type: none"> • Whipping action caused by hose assembly failure. • Possible release of fluid under pressure that can cause injury. • Thermal hazards associated with hot fluid.
Area Inside the Guards and Outside the Mold Area See Figure 3-1 area 10	Crushing and / or shearing and / or impact hazards caused by: <ul style="list-style-type: none"> • Movement of the platen. • Movement of the drive mechanism of the platen. • Movement of the core and ejector drive mechanism. • Clamp opening movement.
Electrical Hazards	<ul style="list-style-type: none"> • Electrical or electromagnetic disturbance generated by the motor control unit. • Electrical or electromagnetic disturbance that can cause failures in the machine control systems and adjacent machine controls. • Electrical or electromagnetic disturbance generated by the motor control unit.
Hydraulic Accumulators	High pressure discharge.
Power Operated Gate	Crush or impact hazards caused by the movement of the power operated gates.
Vapors and gases	Certain processing conditions and / or resins can cause hazardous fumes or vapors.



3.3 Operational Hazards













WARNINGS

- Refer to all machine manuals and local regulations and codes for safety information.
- The equipment supplied is subjected to high injection pressures and high temperatures. Ensure that extreme caution is observed in the operation and maintenance of the injection molding machines.
- Only fully trained personnel should operate or maintain equipment.
- Do not operate the equipment with unconfined long hair, loose clothing or jewelry, including name badges, neckties, etc. These may get caught in the equipment and can cause death or serious injury.
- Never disable or bypass a safety device.
- Ensure that the protective guards are placed around the nozzle to prevent the material from splashing or drooling.
- A burn hazard exists from material during routine purging. Wear heat-resistant personal protective equipment (PPE) to prevent burns from contact with hot surfaces or splatter of hot material and gases.
- Material purged from machine may be extremely hot. Ensure protective guards are in place around the nozzle to prevent material from splashing. Use proper personal protective equipment.
- All operators should wear personal protective equipment, such as face shields and use heat resistant gloves when working around the feed inlet, purging the machine or cleaning the gates of the mold.
- Remove purged material from the machine immediately.
- Decomposing or burning material could result in noxious gases being emitted from the purged material, feed inlet or mold.
- Ensure proper ventilation and exhaust systems are in place to help prevent inhalation of harmful gases and vapors.
- Consult manufacturer's Material Safety Data Sheets (MSDS).
- Hoses fitted to the mold will contain high or low temperature fluids or air under high pressure. The operator must shut down and lockout these systems as well as relieving any pressure before performing any work with these hoses. Regularly inspect and replace all flexible hoses and restraints.
- Water and / or hydraulics on the mold may be in close proximity to electrical connections and equipment. Water leakage may cause an electrical short circuit. Hydraulic fluid leakage may cause a fire hazard. Always keep water and / or hydraulic hoses and fittings in good condition to avoid leaks.
- Never perform any work on the mold machine unless the hydraulic pump has been stopped.
- Check frequently for possible oil leaks / water leaks. Stop the machine and make repairs.



Operational Hazards - continued**WARNING**

- Make sure that the cables are connected to the correct motors. Cables and motors are clearly labeled. Reversing the cables can result in unexpected and uncontrolled motion causing a safety risk or damage to the machine.
- A crushing hazard exists between the nozzle and mold melt inlet during carriage forward motion.
- A possible shearing hazard exists between the edge of the injection guard and the injection housing during injection.
- The open feed port could present a hazard to a finger or a hand inserted during operation of the machine.
- The electric servo motors could overheat presenting a hot surface which could cause burns to someone touching it.
- The barrel, barrel head, nozzle, heater bands and mold components are hot surfaces which could result in burns.
- Keep flammable liquids or dust away from the hot surfaces as they could ignite.
- Follow good housekeeping procedures and keep floors clean to prevent slips, trips and falls due to spilled material on the work floor.
- Apply engineering controls or hearing conservation programs as necessary to control noise.
- When doing any work on the machine that requires moving and lifting the machine, ensure that lifting equipment (eyebolts, fork lift truck, cranes, etc.) will have sufficient capacity to handle mold, auxiliary injection unit or Hot Runner weight.
- Connect all lifting devices and support the machine using a crane of adequate capacity before commencing work. Failure to support the machine can result in severe injury or death.
- Mold cable from the controller to the mold must be removed before servicing the mold.

3.4 General Safety Symbols

Table 3-2 Typical Safety Symbols	
Symbol	General Description
	General – Warning Indicates an immediate or potentially hazardous situation, which if not avoided, could result in a serious injury or death, and / or damage to equipment.
	Warning – Barrel Cover Grounding Strap Lockout / tagout procedures must be followed before removing the barrel cover. Barrel cover can become energized upon removal of grounding straps and contact can result in death or serious injury. Grounding straps must be reconnected before reconnecting power to machine.
	Warning – Crushing and / or Impact Points Contact with moving parts can cause serious crushing injury. Always keep guards in place.
	Warning – Crush Hazard Closing Mold
	Warning – Hazardous Voltage Contact with hazardous voltages will cause death or serious injury. Turn off power and review electrical schematics before servicing equipment. May contain more than one live circuit. Test all circuits before handling to make sure circuits have been de-energized.
	Warning – High Pressure Overheated fluids may cause severe burns. Discharge pressure before disconnecting water lines.
	Warning – High Pressure Accumulator Sudden release of high pressure gas or oil can cause death or serious injury. Discharge all gas and hydraulic pressure before disconnecting or disassembling accumulator.
	Warning – Hot Surfaces Contact with exposed hot surfaces will cause serious burn injury. Wear protective gloves when working near these areas.
	Mandatory – Lockout / Tagout Ensure that all energies are properly locked out, and remain locked out until the service work is completed. Servicing equipment without disabling all internal and external power sources can cause death or serious injury. De-energize all internal and external power sources (electrical, hydraulic, pneumatic, kinetic, potential, and thermal).
	Warning – Molten Material Splashing Hazard Molten material or high pressure gas can cause death or severe burns. Wear personal protective equipment while servicing the feed throat, nozzle, mold areas, and when purging the injection unit.
	Warning – Read Manual Before Operation Personnel should read and understand all instructions in the manuals before working on equipment. Only properly trained personnel should operate the equipment.
	Warning – Slip, Trip or Fall Hazard Do not climb on equipment surfaces. Serious slip, trip or fall injuries can result from personnel climbing on equipment surfaces.

General Safety Symbols - continued

Table 3-2 Typical Safety Symbols	
Symbol	General Description
	Caution Failure to follow instructions may damage equipment.
	Important Indicates additional information or used as a reminder.

3.5 Wiring Check



CAUTION

System Mains Supply Wiring:

- Before connecting the system to a power supply, it is important to check that the wiring between the system and the power supply has been done correctly.
- Particular attention must be given to the current rating of the power supply. For example, if a controller is rated at 63A, then the power supply must also be rated at 63A.
- Check that the phases of power supply are wired correctly.

Controller to Mold Wiring:

- For separate power and thermocouple connections, ensure that the power cables are never connected to the thermocouple connectors and vice-versa.
- For mixed power and thermocouple connections, ensure that the power and thermocouple connections have not been wired incorrectly.

Communications Interface and Control Sequence:

- It is the customer's responsibility to verify functionality of any custom machine interface at safe speeds, prior to operating equipment in the production environment at full speed in automatic mode.
- It is the customer's responsibility to verify all required motion sequences are correct, prior to operating equipment in the production environment at full speed in automatic mode.
- Switching the machinery into Auto mode without having verified the control interlocks and motion sequence are correct, may cause damage to machinery and / or equipment.

Failure to do wiring or connections properly will result in equipment failure.

The use of *Mold-Masters* standard connections can help to eliminate the potential for wiring errors.

Mold-Masters Ltd. cannot be responsible for damage caused by customer wiring and / or connection errors.

3.6 Lockout Safety



WARNING

DO NOT enter the cabinet without first ISOLATING the supplies.

High voltage and amperage cables are connected to the controller and the mold. There is also a high voltage cable connection between the servo motor and the controller. Electrical power must be shut off and lockout / tagout procedures followed prior to installing or removing any cables.

Use lockout / tagout to prevent operation during maintenance.

All maintenance should be performed by properly trained personnel based on local laws and regulation. Electrical products may not be grounded when removed from the assembled or normal operating condition.

Ensure proper grounding of all electrical components before performing any maintenance to avoid potential risk of electrical shock.

Often power sources are inadvertently turned on or valves are opened mistakenly before maintenance work is completed, resulting in serious injuries and fatalities. Therefore, it is important to ensure that all energies are properly locked out and that they remain locked out until the work is completed.

If a lockout is not performed, uncontrolled energies could cause:

- Electrocution from contact with live circuits
- Cuts, bruises, crushing, amputations or death, resulting from entanglement with belts, chains, conveyors, rollers, shafts, impellers
- Burns from contact with hot parts, materials, or equipment such as furnaces
- Fires and explosions
- Chemical exposures from gases or liquids released from pipelines



3.6.1 Electrical Lockout

WARNING - READ MANUAL

Refer to all machine manuals and local regulations and codes.

NOTE

In some instances, there may be more than one power source feeding equipment and steps must be taken to ensure that all sources are effectively locked out.

Employers must provide an effective lockout / tagout program.

1. Shut down machine using normal operational shutdown procedure and controls. This should be done by, or in consultation with the machine operator.
2. After ensuring that the machinery has been completely shut down, and all controls in the “off” position, open the main disconnect switch located in the field.
3. Using your own personal padlock, or one assigned by your supervisor, lock the disconnect switch in the off position. Do not lock only the box. Remove the key and retain. Complete a lockout tag and affix to the disconnect switch. Each person working on the equipment must follow this step. The lock of the person doing the work or in charge must be installed first, remain throughout and be removed last. Test the main disconnect switch and make sure it cannot be moved to the “on” position.
4. Try to start the machine using the normal operation controls and point of operation switches to make sure that the power has been disconnected.
5. Other sources of energy that could create a hazard while working on the equipment must also be de-energized and appropriately “locked-out”. This can include gravity, compressed air, hydraulics, steam and other pressurized or hazardous liquids and gases. See Table 3-3.
6. When the work is completed, prior to removing the last lock, make sure the operational controls are in the “off” position so that the main disconnect switching is done under “no load”. Ensure all blocks, tools and other foreign materials are removed from machine. Also ensure that all personnel that may be affected are informed that the lock(s) will be removed.
7. Remove lock and tag, and close the main disconnect switch if permission has been given.
8. When the work has not been completed on the first shift, the next operator should install a personal lock and tag before the first operator removes the original lock and tag. If the next operator is delayed, a lock and tag could be installed by the next supervisor. Lockout procedures should indicate how the transfer is to be conducted.
9. It is important that, for their personal protection, each worker and/or fore person working in or on a machine places his/her own safety lock on the disconnect switch. Use tags to spotlight work in progress and give details of work being done. Only when the work is completed and the work permit signed off, may each worker remove his/her lock. The last lock to be removed should be that of the person supervising the lockout and this responsibility should not be delegated.

© Industrial Accident Prevention Association, 2008.

3.6.2 Energy Forms and Lockout Guidelines

Table 3-3 Energy Forms, Energy Sources and General Lockout Guidelines		
Energy Form	Energy Source	Lockout Guidelines
Electrical Energy	<ul style="list-style-type: none"> • Power transmission lines • Machine power cords • Motors • Solenoids • Capacitors (stored electrical energy) 	<ul style="list-style-type: none"> • Turn off power at machine first (i.e., at point of operation switch), and then at the main disconnect switch for the machine. Lock and tag the main disconnect switch. • Fully discharge all capacitive systems (e.g., cycle machine to drain power from capacitors) according to the manufacturer's instructions.
Hydraulic Energy	<ul style="list-style-type: none"> • Hydraulic systems (e.g., hydraulic presses, rams, cylinders, hammers) 	<ul style="list-style-type: none"> • Shut off, lock (with chains, built-in lockout devices, or lockout attachments) and tag valves. • Bleed off and blank lines as necessary.
Pneumatic Energy	<ul style="list-style-type: none"> • Pneumatic systems (e.g., lines, pressure reservoirs, accumulators, air surge tanks, rams, cylinders) 	<ul style="list-style-type: none"> • Shut off, lock (with chains, built-in lockout devices, or lockout attachments) and tag valves. • Bleed off excess air. • If pressure cannot be relieved, block any possible movement of machinery.
Kinetic Energy (Energy of a moving object or materials. Moving object may be powered or coasting)	<ul style="list-style-type: none"> • Blades • Flywheels • Materials in supply lines 	<ul style="list-style-type: none"> • Stop and block machine parts (e.g. stop flywheels and ensure that they do not recycle). • Review entire cycle of mechanical motion, ensure that all motions are stopped. • Block material from moving into area of work. • Blank as required.
Potential Energy (Stored energy that an object has the potential to release due to its position)	<ul style="list-style-type: none"> • Springs (e.g., in air brake cylinders) • Actuators • Counterweights • Raised loads • Top or movable part of a press or lifting device 	<ul style="list-style-type: none"> • If possible, lower all suspended parts and loads to the lowest (rest) position. • Block parts that might be moved by gravity. • Release or block spring energy.
Thermal Energy	<ul style="list-style-type: none"> • Supply lines • Storage tanks and vessels 	<ul style="list-style-type: none"> • Shut off, lock (with chains, built-in lockout devices, or lockout attachments) and tag valves. • Bleed off excess liquids or gases. • Blank lines as necessary.

3.7 Disposal



WARNING

Mold-Masters declines any responsibility for personal injury or personal damage arising from reuse of the individual components, if these parts are used other than for the original and proper intended purpose.

1. Hot Runner and system components must be disconnected from the power supply fully and properly before disposal, including electricity, hydraulics, pneumatics and cooling.
2. Ensure that the system to be disposed of is free from fluids. In the case of hydraulic needle valve systems, drain the oil from the lines and cylinders and dispose it in an environmentally responsible manner.
3. The electrical components are to be dismantled, separating them accordingly as environmentally friendly waste or disposed as hazardous waste if necessary.
4. Remove the wiring. The electronic components are to be disposed in accordance with the national electric scrap ordinance.
5. The metal parts are to be returned for metal recycling (waste metal and scrap trade). The instructions of the corresponding waste disposal company are to be observed in this case.

Recycling of the materials occupies a forefront position during the disposal process.

3.8 Fusion-Series G3 Safety Hazards



WARNING

- The equipment supplied is subjected to high injection pressures and high temperatures.
- Ensure that extreme caution is observed in the operation and maintenance of the Hot Runner system and the injection molding machines.
- Do not operate the equipment with unconfined long hair, loose clothing or jewelry, including name badges, neckties, etc. These may get caught by the moving belt mechanism and can cause death or serious injury.
- Never disable or bypass a safety device.
- All operators should wear personal protective equipment, such as face shields, and use heat resistant gloves when working around the feed throat, purging the machine or cleaning the gates of the mold.
- Check frequently for possible oil or water leaks. Stop the machine and make repairs.
- Do not look directly into the feed throat of a hopper. Unexpected release of resin may cause serious burns. Use a mirror. Failure to do so may cause serious injury.
- Remove purgings from the machine immediately. Never directly handle plastic purgings or drool until they have completely cooled. Purgings may appear solid but may still be hot and cause serious injury.
- Some plastics develop gases that may be dangerous to personal health. Follow the plastics supplier's recommendations. Review their material safety data sheet. Ensure the molding area is well ventilated.
- Never touch or inspect the timing belt when power is on and motor and controller are connected.
- Always cover E-Drive belt area / molding machine drop out area / bench top with a proper protective cover before any bench test or in-mold testing.
- Voltage and amperage cables are connected to the controller and the mold. Electric power must be shut off and lockout / tagout procedures followed prior to installing or removing any cables. There is also a high voltage cable connection between the servo motor and controller.
- Always unplug the controller before performing any maintenance work.
- Hoses fitted to the mold will contain high or low temperature fluids or air under high pressure. The operator must shut down and lockout these systems as well as relieving any pressure before performing any work with these hoses.
- Never perform any work on the mold unless the hydraulic pump has been stopped.

Fusion Series Safety Hazards - continued**WARNING**

- Water and / or hydraulics on the mold may be in close proximity to electrical connections and equipment. Water leakage may cause an electrical short circuit. Hydraulic fluid leakage may cause a fire hazard. Always keep water and / or hydraulic hoses and fittings in good condition to avoid leaks.
- Make sure the lifting eyebolt, lifting chain and crane are rated to adequately support the weight of the plate(s). Failure to do so can cause a serious injury.
- All maintenance on *Mold-Masters* products should be performed by properly trained personnel based on local law or regulation requirements.
- Ensure proper grounding of all electrical products before performing any maintenance to avoid potential risk of electrical shock.
- Make sure the machine has been locked out and tagged out in accordance to the machine's documented procedures. Failure to do so may lead to serious injury or death.
- Check that all coolant, hydraulic and air lines as well as electrical cables will not interfere with the moving parts of the mold, machine or robot. The lines must be of sufficient length so that they will not strain or pinch when the mold halves separate.
- For water cooling nozzle jacket, coolant must be maintained with the proper mixture to prevent corrosion and circuit blockage.
- Care must be taken to ensure the nozzle terminal ends do not come in contact with the hydraulic fluid. The nozzles may short out or become damaged.
- Do not mix electrical power cables with thermocouple extension cables. They are not designed to carry the power load or list accurate temperature readings in each other's application.

Fusion Series Safety Hazards - continued**CAUTION**

All *Mold-Masters* heated components are manufactured to standards that ensure safe and reliable operation provided that the following precautions are met:

- To maximize heater element and component life, the temperature must be controlled and maintained within safe operating limits. *Mold-Masters* strongly recommends individual control of each heated component, including heater plates, with a reliable temperature controller that includes soft-start protection.
- Always operate the system using correctly installed “J” type thermocouples connected to a reliable temperature controller with soft-start protection.
- Avoid running the system for long periods on manual control.
- Use caution when applying power in manual mode. Use minimum heat required for the process to avoid overheating and possible damage to components.
- Always replace pinched or damaged thermocouples.
- When grouping heated components together and controlling more than one load from a single thermocouple, make sure that the components are of similar material, wattage, size and are exposed to the same thermal conditions.
- When replacing heater plates or other heated components always replace with *Mold-Masters* components of the same type and install as originally specified on *Mold-Masters* General Assembly drawings.

Section 4 - Preparation



WARNING

Ensure that you have fully read “Section 3 - Safety” before unpacking, cleaning or assembling parts of your Fusion Series system.

The following section is a step-by-step guide to prepare your *Mold-Masters* system for use.

4.1 Tools Required

Depending on the size and complexity of your Hot Runner system, you will require most of the tools and materials listed below.

- Allen keys: Depending on system, set of metric or imperial size keys to use 4, 5, 6, 8, 10 and 14 mm (5/32”, 3/16”, 1/4”, 5/16”, 3/8” and 1/2”) in.) on cap screws.
- Nickel based anti-seize compound: to prevent oxidation of screw threads that could cause screws to seize with high temperatures
- Solvents (denatured alcohol): for removal of rust inhibitors
- Calibrated torque wrench: for consistent screw pressure throughout the system
- Depth micrometer: to check bore depths
- Die spotting blue compound: for checking face contact
- Sockets
- Plastic face hammer

4.2 Screw Lengths



WARNING

Be aware of warnings placed on the assembly drawings. When the manifold is heated the metal expands stretching the mounting screws, if screw lengths are shortened there is a possibility of shearing.

The expansion factor is calculated into the length of each screw size.



CAUTION

The use of an incorrect size, length and grade screw could cause the screw to shear, fatigue or stretch beyond its yield point, resulting in expensive downtime of the Hot Runner.

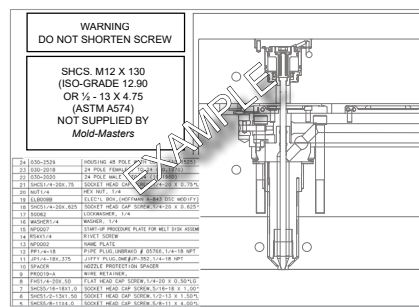

4.3 Unpacking



WARNING

Make sure the lifting eyebolt, lifting chain and crane are rated to adequately support the weight. Failure to do so can cause a serious injury.

Make sure the machine has been locked out and tagged out in accordance to the machines documented procedures. Failure to do so may lead to serious injury or death.

1. Carefully open the shipping crate and inspect contents. Secure loose items and check that the system is received in good condition and no damage occurred during shipment. Remove any documentation or spares packages and set aside.
2. After removing all restraints, attach the crane to the hoist and carefully remove the system from the shipping crate.
3. Check that all mold base dimensions are correct and correspond to *Mold-Masters* General Assembly drawings.

4.4 Cleaning

All nozzles, manifolds and Hot Runner components must be free of the rust inhibitor applied at the factory.

4. Remove protective covers from all gate seals.
5. Clean all surfaces and dowel holes, ensuring that no debris, burrs, shavings, dust, dirt or other foreign material which could interfere with measurements, exists. Ream holes out if necessary.
6. Remove tape from inlet and clean.

4.5 Hydraulic Actuator

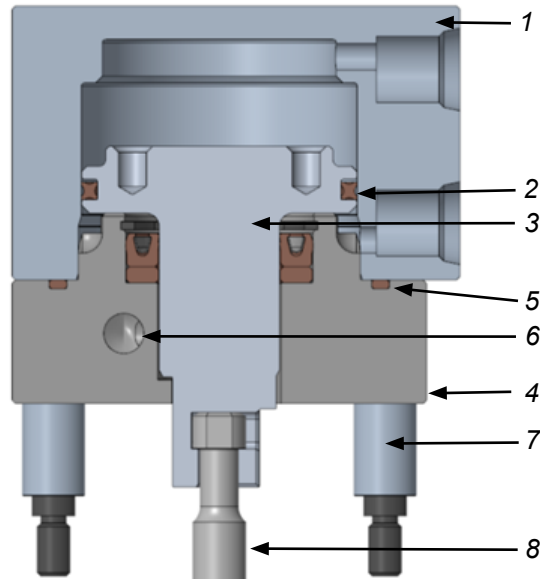

Figure 4-2 Hydraulic actuator assembly sectional view 1

- | | |
|--------------------|-------------------------|
| 1. Cylinder top | 5. Cylinder bottom seal |
| 2. Piston seal | 6. Cooling channel |
| 3. Piston bottom | 7. Support spacer |
| 4. Cylinder bottom | 8. Valve pin |

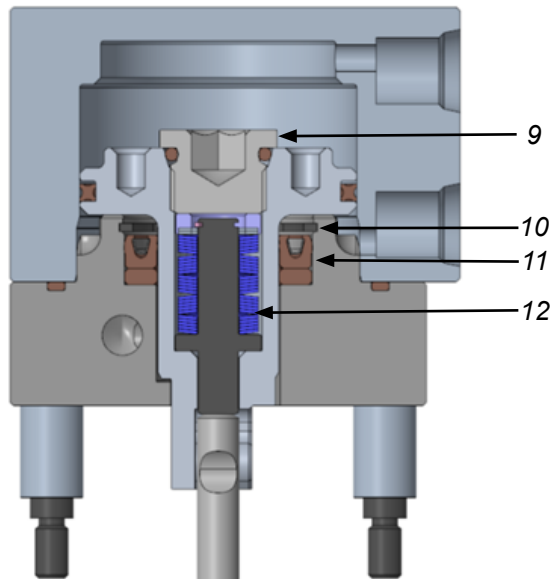
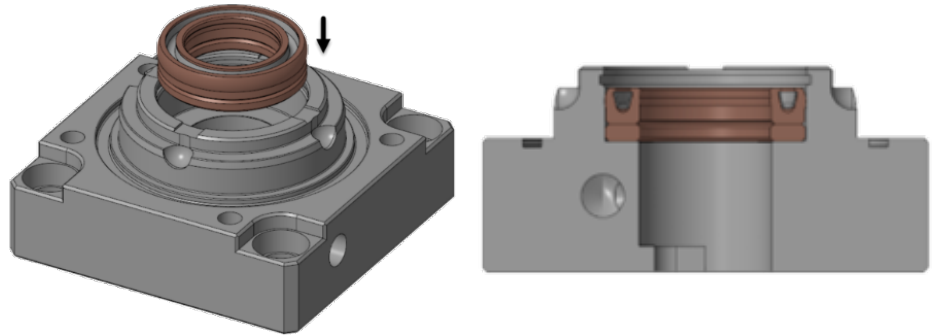

Figure 4-3 Hydraulic actuator assembly sectional view 2

- | |
|--------------------|
| 9. Piston top |
| 10. Retaining ring |
| 11. Rod seal |
| 12. Spring pack |

1. Install the rod seal assembly into the pocket of the cylinder bottom.



2. Install the rod seal retainer clip.

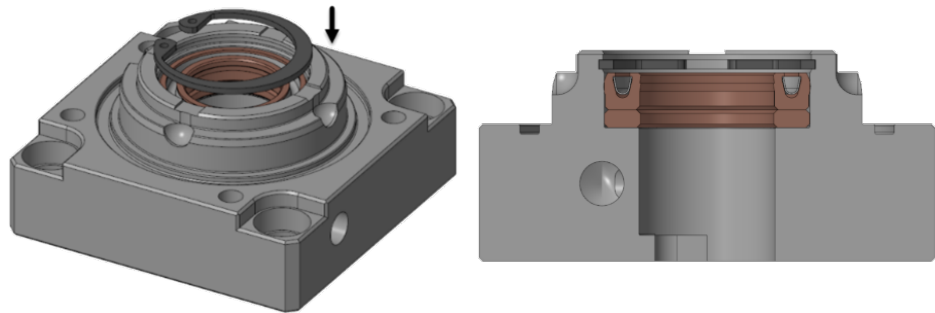

3. Apply pipe sealant to the threads of the water-circuit pipe plug.
4. Install the water-circuit pipe plug.

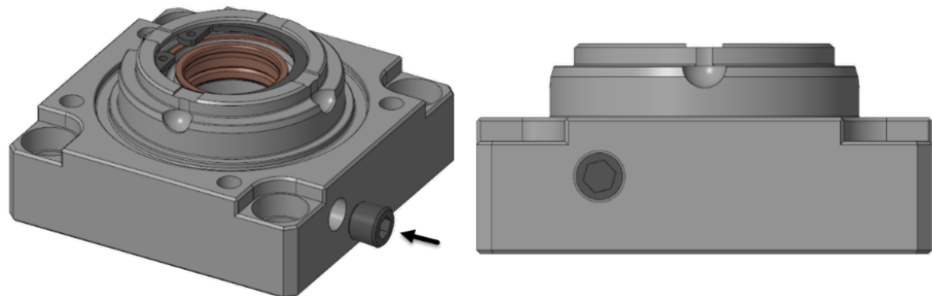

5. Install the four support spacers.

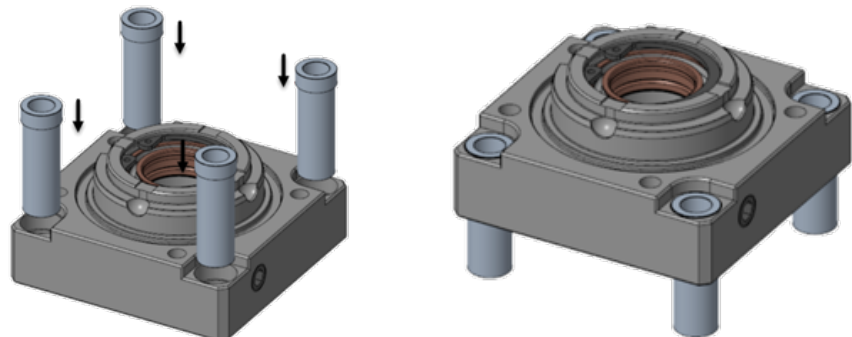

6. Install the cylinder bottom seal.

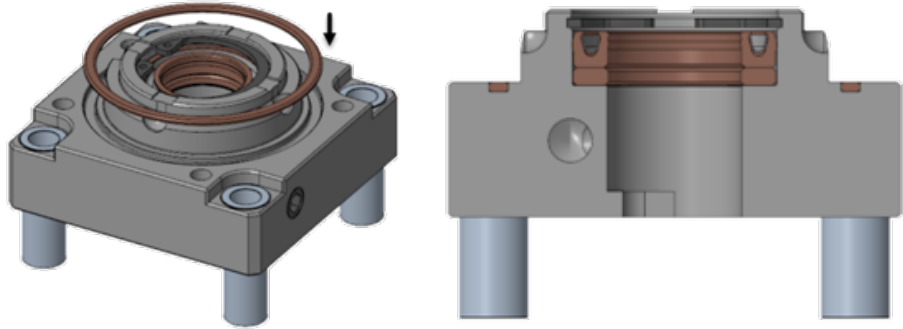

7. Install the piston seal.

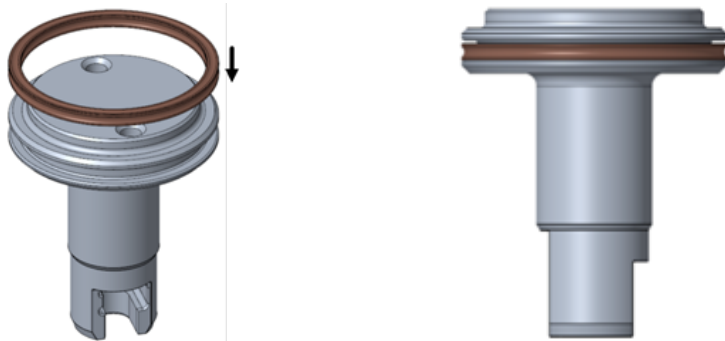

8. Optional: Install the spring pack and spacer.

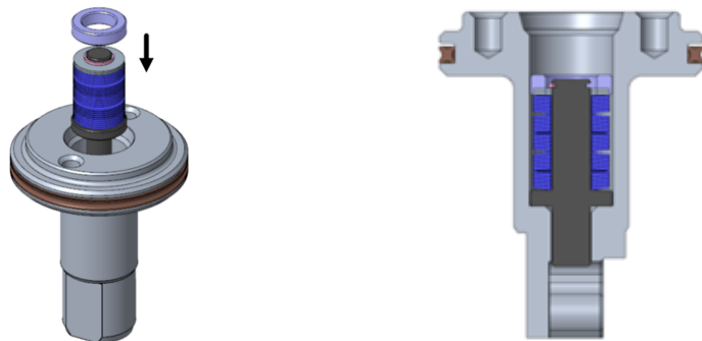

9. Optional: Install the piston top.



10. Optional: Tighten the piston top by putting it in a soft jaw vise and tightening it to a torque of 10 Nm (7 lb-ft).

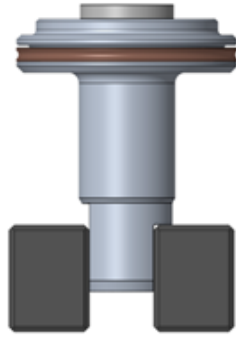

11. Install the piston in the cylinder bottom.

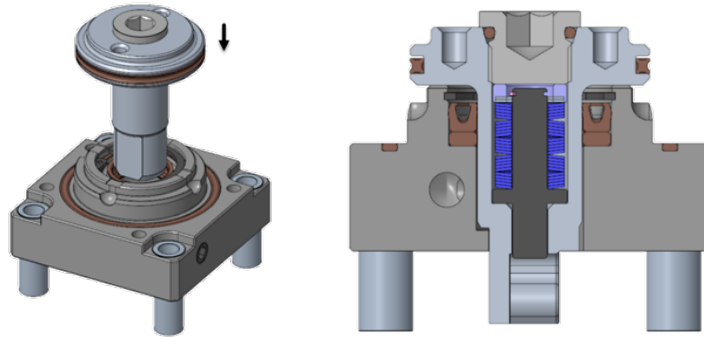

12. Install the cylinder top on the cylinder bottom.

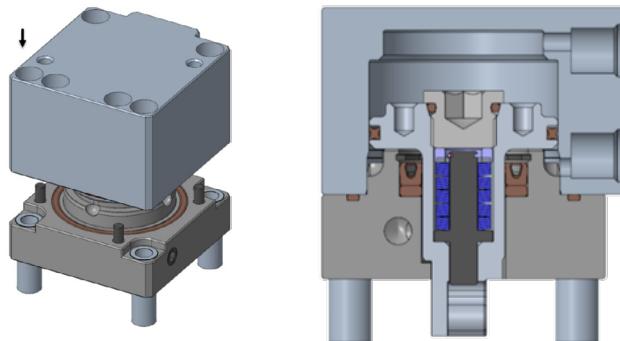

13. Apply thread-lock compound to the two button-head cap screws.

14. Insert two spacers (3.5 mm thick) in each of the two spacer-storing pockets using the two button-head cap screws.

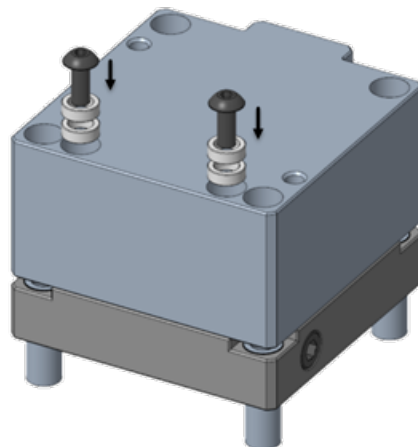

15. Install four spacers (3.0 mm thick) between the cylinder top and the cylinder bottom.

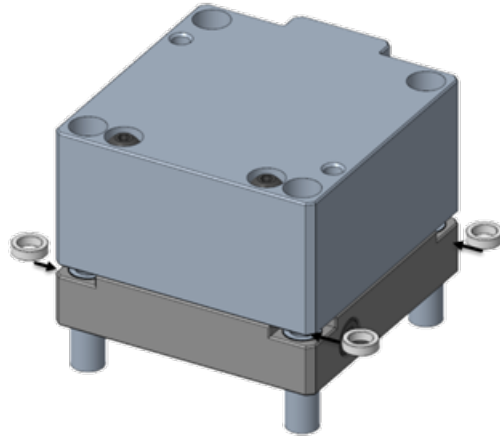

16. Apply anti-seize compound to the screws.
17. Rotate the assembly, and install the screws in the bottom of the cylinder.

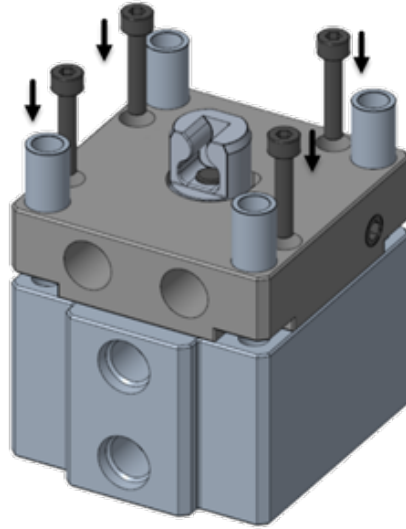

4.5.1 Adjust the Hydraulic Actuator Stroke (Optional)

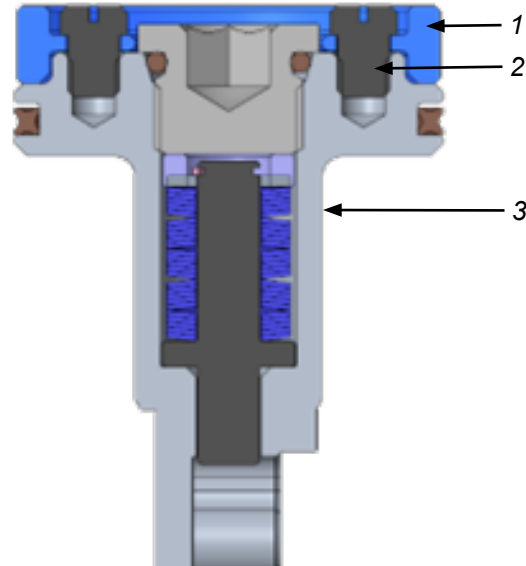

1. Stroke-adjusting spacer
2. Cheese head screw
3. Piston assembly

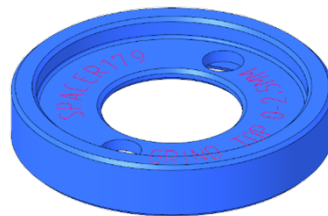

Figure 4-4 Stroke-adjusting spacer



NOTE

The stroke-adjusting spacer reduces the stroke by 7.5 mm.

To reduce the stroke by 5 mm, remove 2.5 mm from the top (marked surface) of the stroke-adjusting spacer. Do not remove more than 2.5 mm from the top of the spacer.

1. Place the stroke-adjusting spacer on top of the piston assembly.
2. Apply thread-locking compound to the threads of the cheese head screws.
3. Insert and tighten the cheese head screws.

4.5.2 Adjust the Valve Pin Position (Optional)



WARNING

Surfaces retain heat. Always wear personal protective equipment.

The following procedure is for situations in which the valve pin length requires adjustment. To change the thickness of the spacer between the cylinder top and the cylinder bottom:

1. Determine the required adjustment of the valve pin position in a hot condition.
2. Cool the system to room temperature (between 10 and 40°C (50 and 104°F)).
3. Remove the four shoulder-head cap screws.
4. Slide the actuator to disengage the actuator from the valve pin.
5. Remove the four spacers installed between the cylinder top and the cylinder bottom.
6. Refer to “Table 4-1 Height-Adjusting Spacer Combinations” to adjust the spacer thickness.

Table 4-1 Height-Adjusting Spacer Combinations		
Valve Pin Length	Spacer Thickness	Adjustment
Too long	3.5 mm	Lift the actuator by 0.5 mm: Remove 0.5 – required adjustment of material from the 3.5 mm spacer.
Nominal	3.0 mm	
Too short		Lower the actuator as required (up to 1.0 mm): Remove the required adjustment from the 3.0 mm spacer.

4.6 Pneumatic Actuator

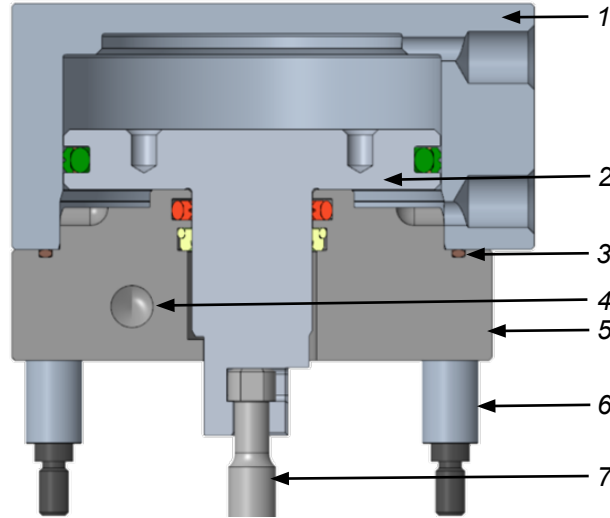

Figure 4-5 Pneumatic actuator assembly sectional view 1

- | | |
|-------------------------|--------------------|
| 1. Cylinder top | 5. Cylinder bottom |
| 2. Piston bottom | 6. Support spacer |
| 3. Cylinder bottom seal | 7. Valve pin |
| 4. Cooling channel | |

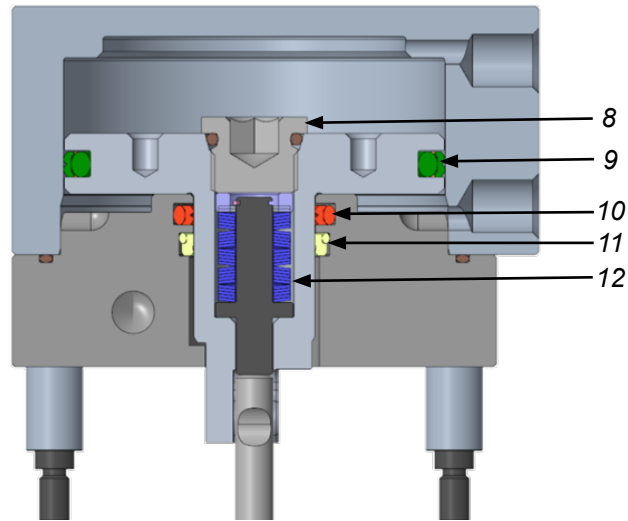
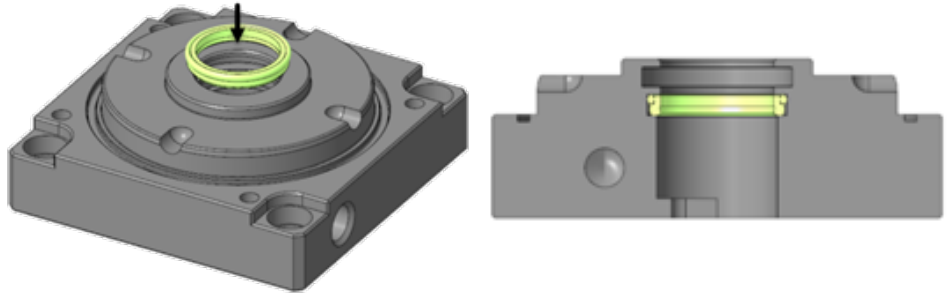

Figure 4-6 Pneumatic actuator assembly sectional view 2

- | |
|-----------------|
| 8. Piston top |
| 9. Piston seal |
| 10. Rod seal |
| 11. Wiper seal |
| 12. Spring pack |

1. Install the two wiper seals. Use the piston to push the seals into position.



2. Install the two rod seals. Use the piston to push the seals into position.

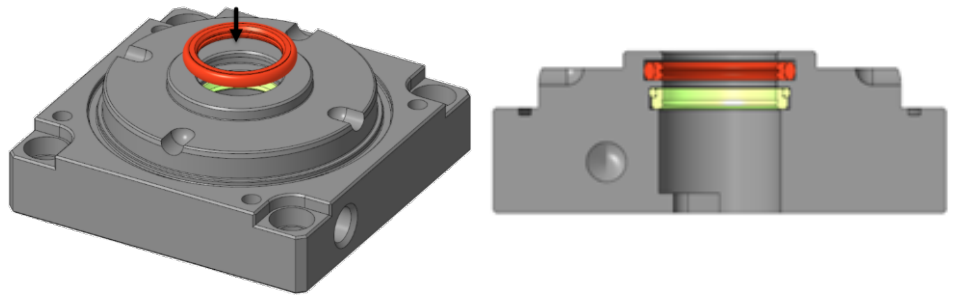

3. Apply pipe sealant to the threads of the water-circuit pipe plug.
4. Install the water-circuit pipe plug.

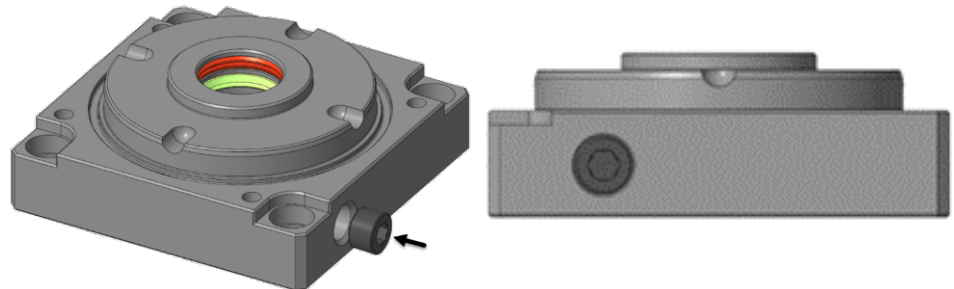

5. Install the four support spacers.

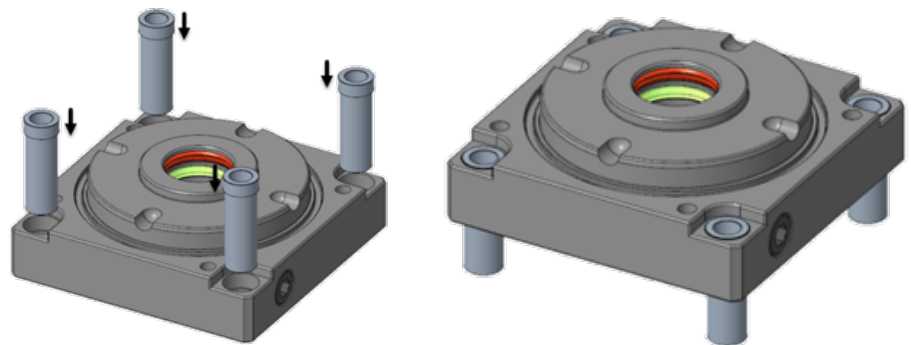

- 6. Install the cylinder bottom seal.

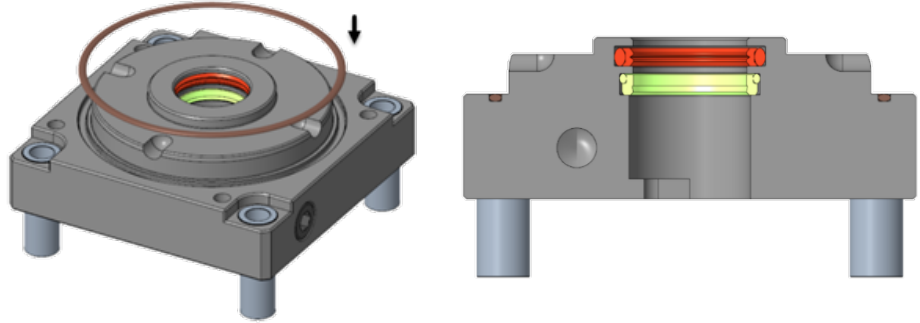

- 7. Install the two piston seals.

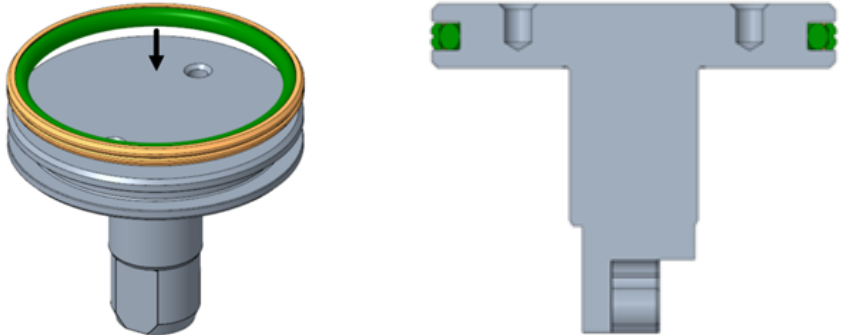

- 8. Optional: Install the spring pack and the spacer.

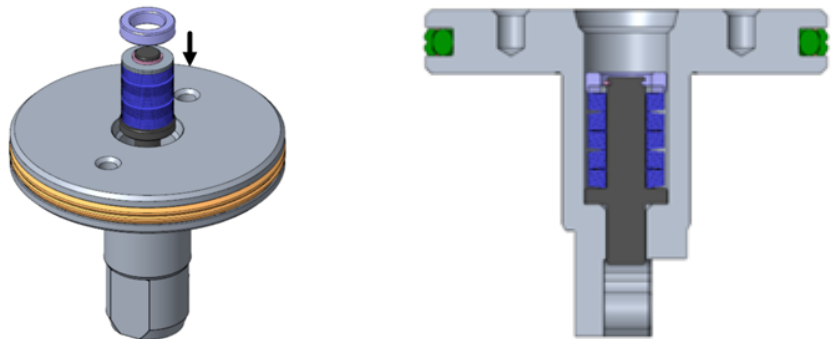

- 9. Optional: Install the piston top.

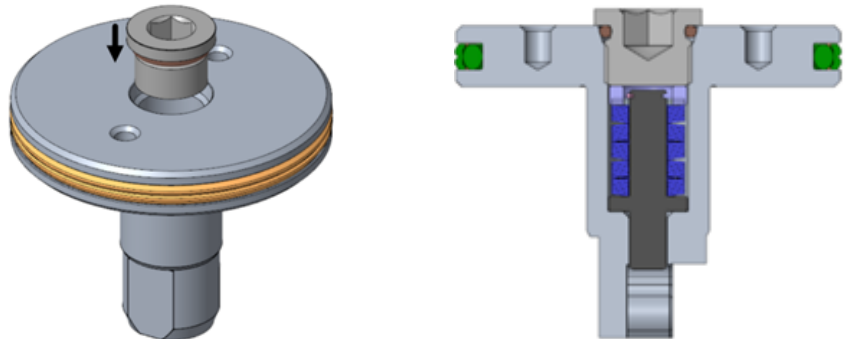

10. Optional: Put the piston top in a soft jaw vise to prevent damage to the part.
11. Optional: Tighten the piston top to a torque to a torque of 10 Nm (7 lb-ft).

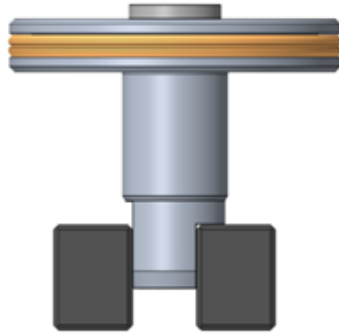

12. Install the piston in the cylinder bottom.

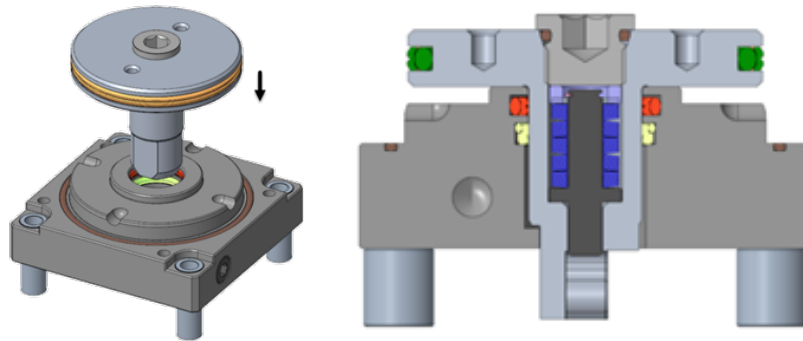

13. Install the cylinder top in the cylinder bottom.

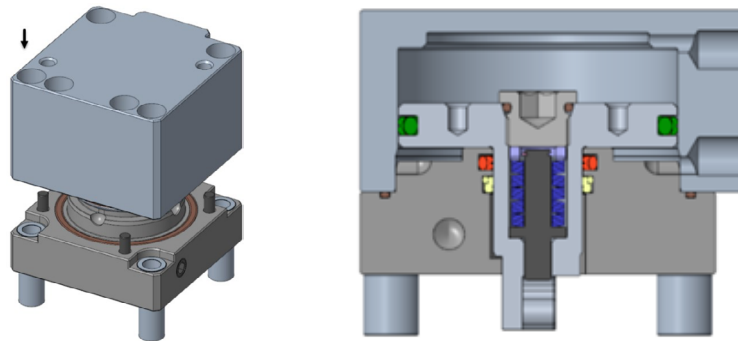

14. Apply thread-lock compound to the button-head cap screws.

15. Insert two spacers (3.5 mm thick) in each of the two spacer-storing pockets using the two button-head cap screws.

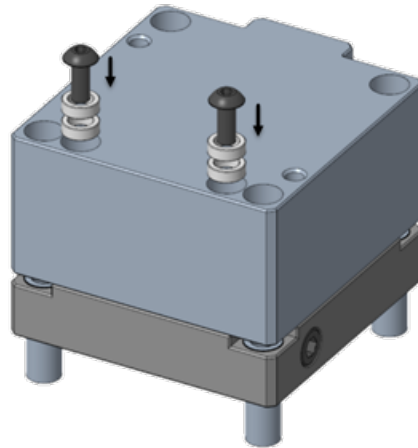

16. Install four spacers (3.0 mm thick) between the cylinder top and the cylinder bottom.

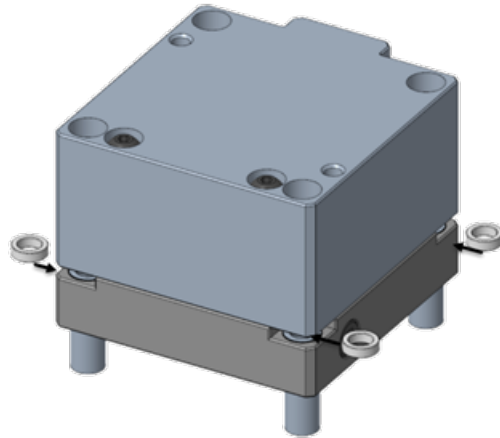

17. Apply anti-seize compound to the screws.

18. Rotate the assembly, and install the screws in the bottom of the cylinder.

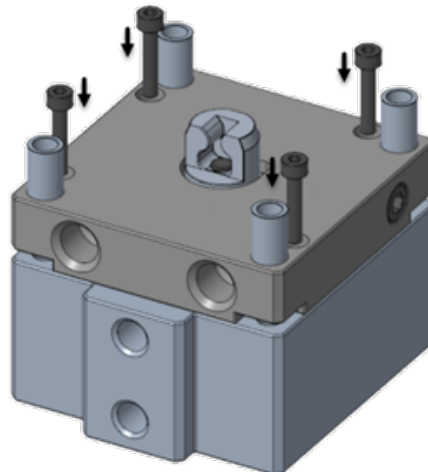

4.6.1 Adjust the Pneumatic Actuator Stroke (Optional)

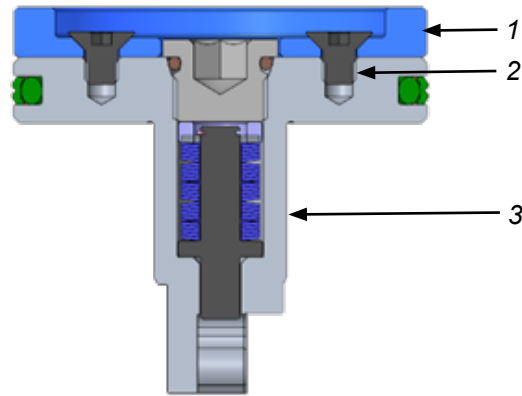

1. Stroke-adjusting spacer
2. Flat head screw
3. Piston assembly

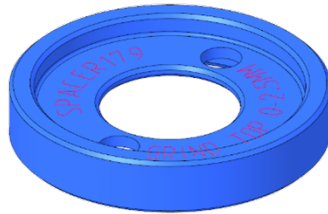

Figure 4-7 Stroke-adjusting spacer



NOTE

The stroke-adjusting spacer reduces the stroke by 7.5 mm.

To reduce the stroke by 3 mm, remove 4.5 mm from the top (marked surface) of the stroke-adjusting spacer. Do not remove more than 4.5 mm from the top of the spacer.

1. Place the stroke-adjusting spacer on top of the piston assembly.
2. Apply thread-locking compound to the threads of the flat head screws.
3. Insert the flat head screws and tighten the flat head screws to a torque of 5.5 N·m (4.0 ft-lbs).

4.6.2 Adjust the Valve Pin Position (Optional)

See section section 4.5.2 Adjust the Valve Pin Position (Optional) on page 4-9.

4.7 Waterless Hydraulic Actuator

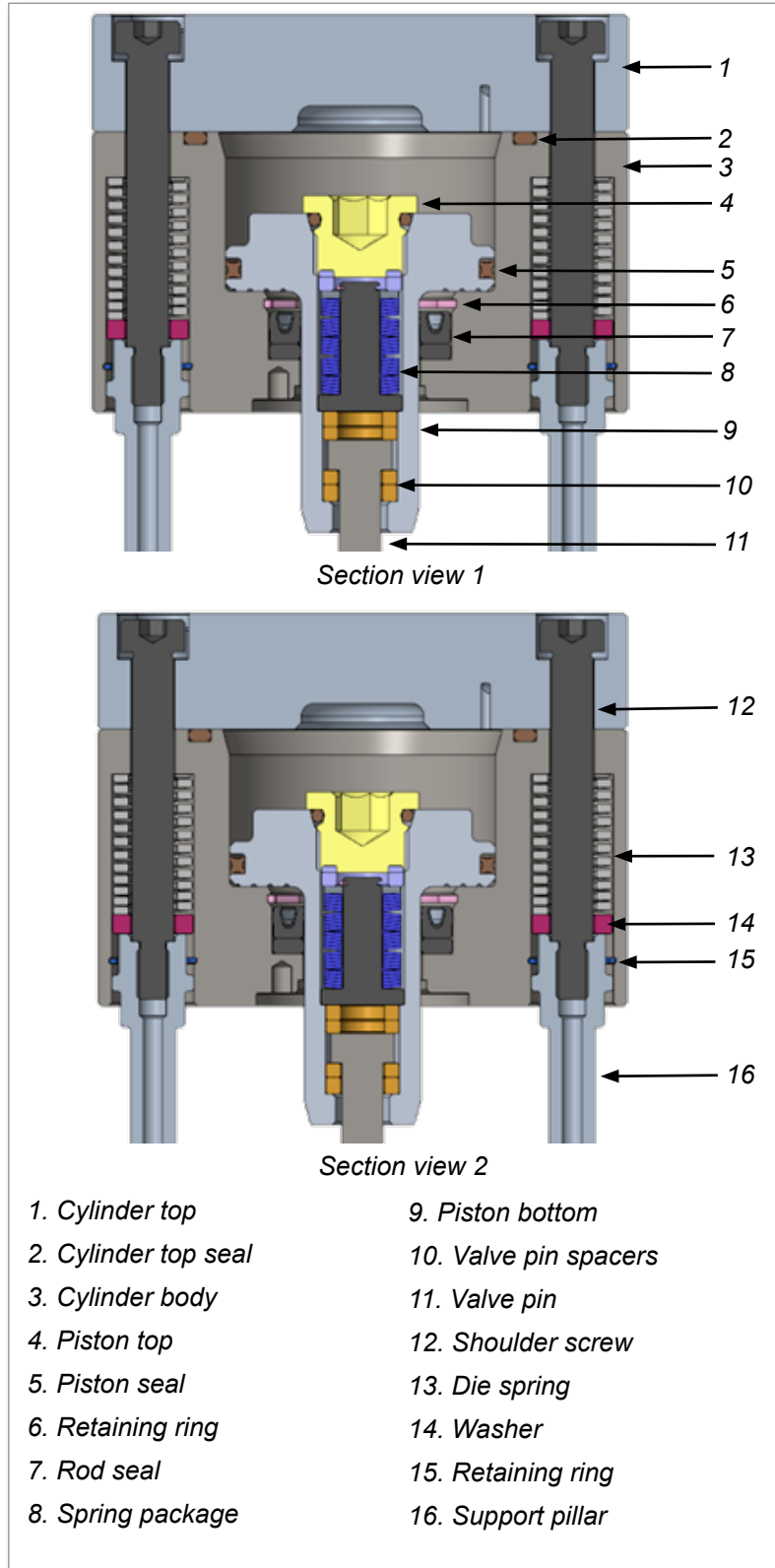
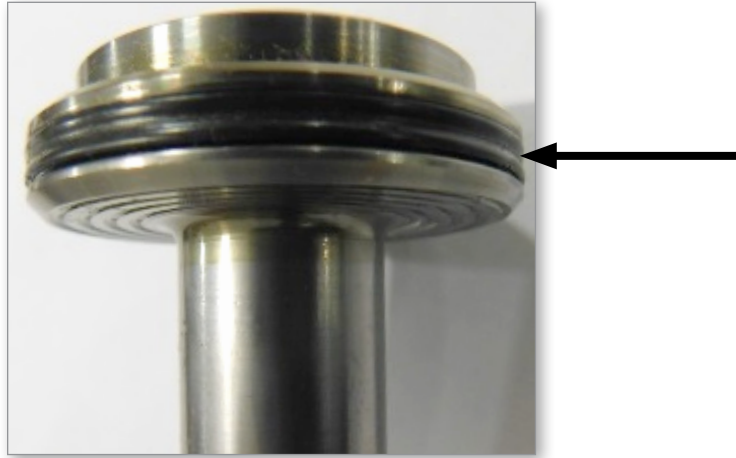

Figure 4-8 Components of the waterless hydraulic actuator

4.7.1 Assemble the Piston

Tools needed for this procedure: a soft jaw vise.

1. Examine the piston seal and make sure that it is in good condition.
2. Install the piston seal.



3. Install valve pin spacers (X and Z) into the piston bore (refer to the Valve Pin and Spacer Combinations Chart.).
4. Insert the valve pin.



5. Install the remaining two valve pin spacers (W and Y) on top of the valve pin (refer to the Valve Pin and Spacer Combinations Chart.)

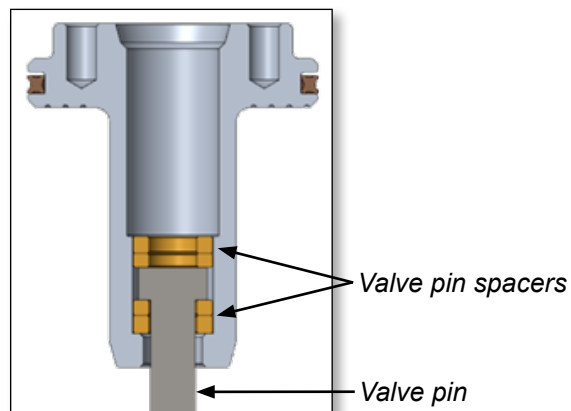

6. Install the solid spacer or spring pack.



7. Install the piston top.

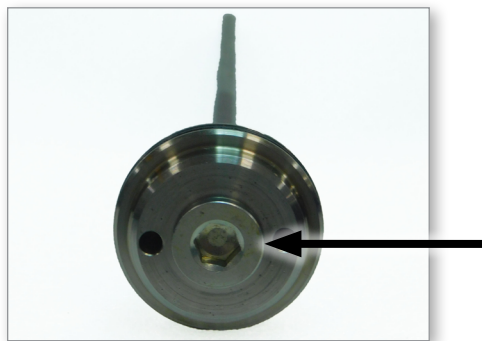

CAUTION

Use a soft jaw vise when tightening the piston top to prevent damage to the piston assembly.

8. Using a soft jaw vise, tighten the piston top to a torque of 10 N·m (7 lb·ft).

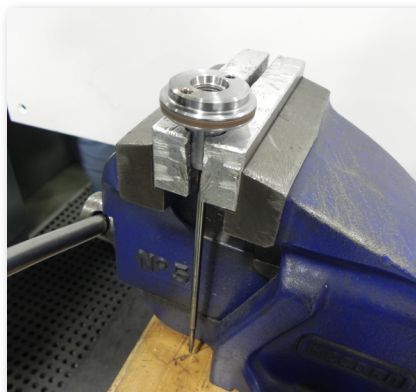

4.7.2 Adjust the Valve Pin Length (Optional)



WARNING

Surfaces may retain heat. Always use personal protective equipment.

This procedure is optional for situations in which the valve pin length requires adjustment.

1. Check the required adjustment of valve pin length in hot condition.
2. Cool down the system to room temperature, between 10°C and 40°C (50°F and 104°F), and remove valve pin from piston.
3. Refer to "Table 4-2 Valve Pin and Spacer Combinations" to choose the correct spacer combination for the length adjustment.

Table 4-2 Valve Pin and Spacer Combinations					
Valve Pin Length	Valve Pin Adjustment	Under Pin Head		Above Pin Head	
		Spacer Combination	Total Thickness	Spacer Combination	Total Thickness
Shorten (pin too long)	-0.20	Y and Z	5.0	W and X	4.20
Nominal	0.00	X and Z	4.80	W and Y	4.40
Lengthen (pin too short)	+0.20	W and Z	4.60	X and Y	4.60
	+0.40	W and Y	4.40	X and Z	4.80
	+0.60	W and X	4.20	Y and Z	5.00
W thickness = 2.00 (5,6,8 Pin), 2.40 (3 Pin)			Y thickness = 2.40 (5,6,8 Pin), 2.80 (3 Pin)		
X thickness = 2.20 (5,6,8 Pin), 2.60 (3 Pin)			Z thickness = 2.60 (5,6,8 Pin), 3.00 (3 Pin)		

4.7.3 Assemble the Cylinder Body

Tools needed for this procedure: snap ring pliers and a 12.0 mm (0.5 in.) diameter rod.

1. Insert the die spring into the cylinder bore hole.



2. Insert the washer into the bore hole.

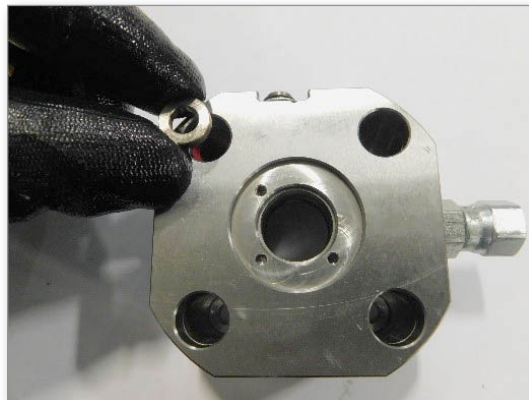

3. Compress the clip and press it into the bore hole.



4. Push down the clip with a 12.0 mm (0.5 in.) diameter rod.

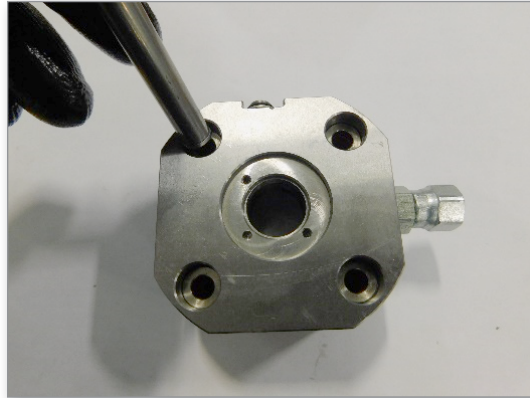

5. Install the spacer and the rod seal.

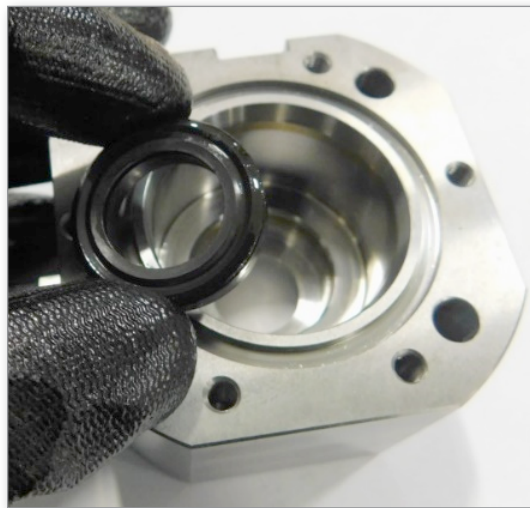

6. Use snap ring pliers to install the retaining ring.



4.7.4 Assemble the Cylinder

1. Install the O-ring seal in the top of the cylinder.

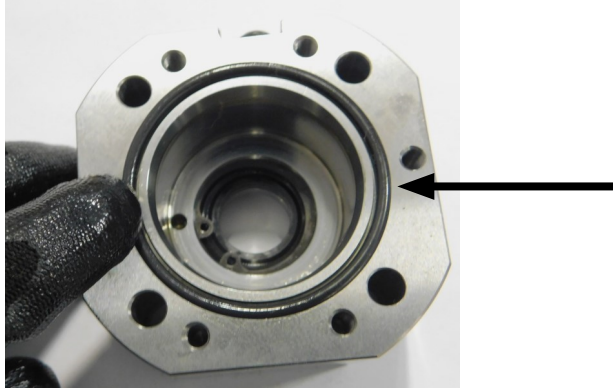

2. Install the assembled piston in the cylinder housing.

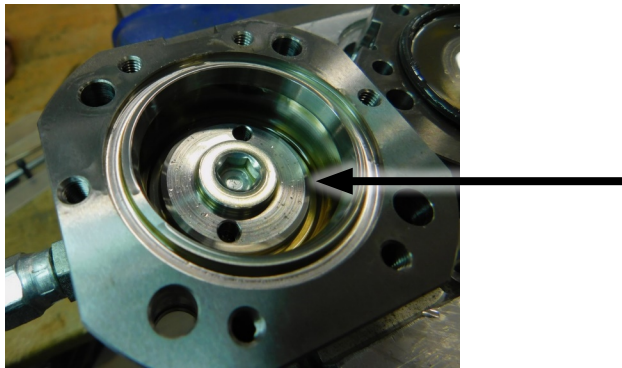

3. Install the spacer in the cylinder top (10 mm stroke).
4. Attach the cylinder top to the cylinder bottom.



5. Apply anti-seize compound to the threads of the screws.

6. Install the screws in the cylinder top and tighten them to a torque of 16 N·m (11.8 ft·lb).

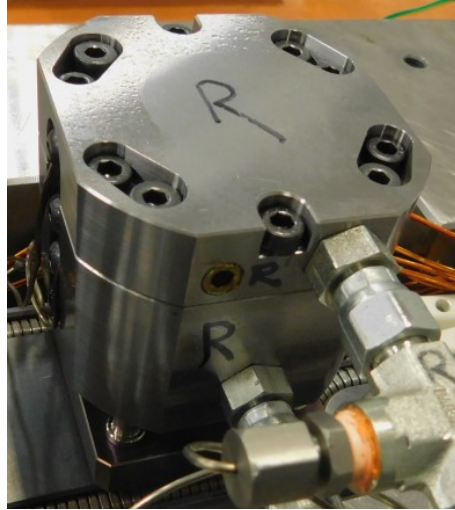

4.7.5 Assemble the Anti-Rotation Waterless Hydraulic Actuator

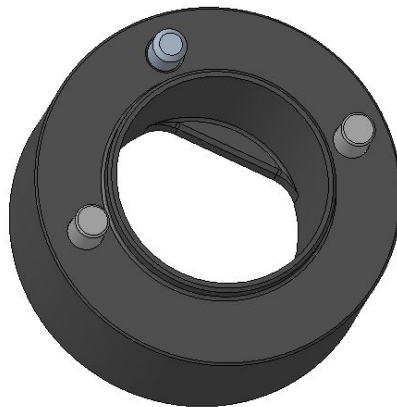
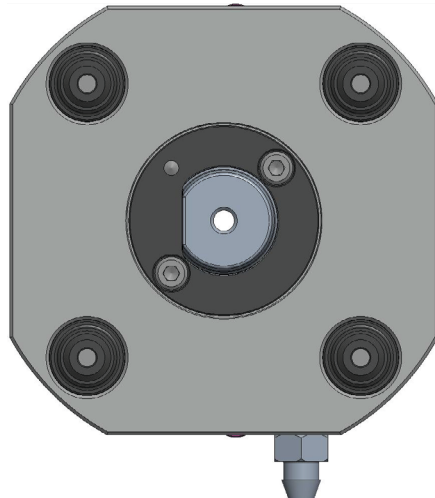

Figure 4-9 Piston collar, dowel pin, and screws

1. Install the piston collar in the bottom of the cylinder.



4.8 Waterless Pneumatic Actuator

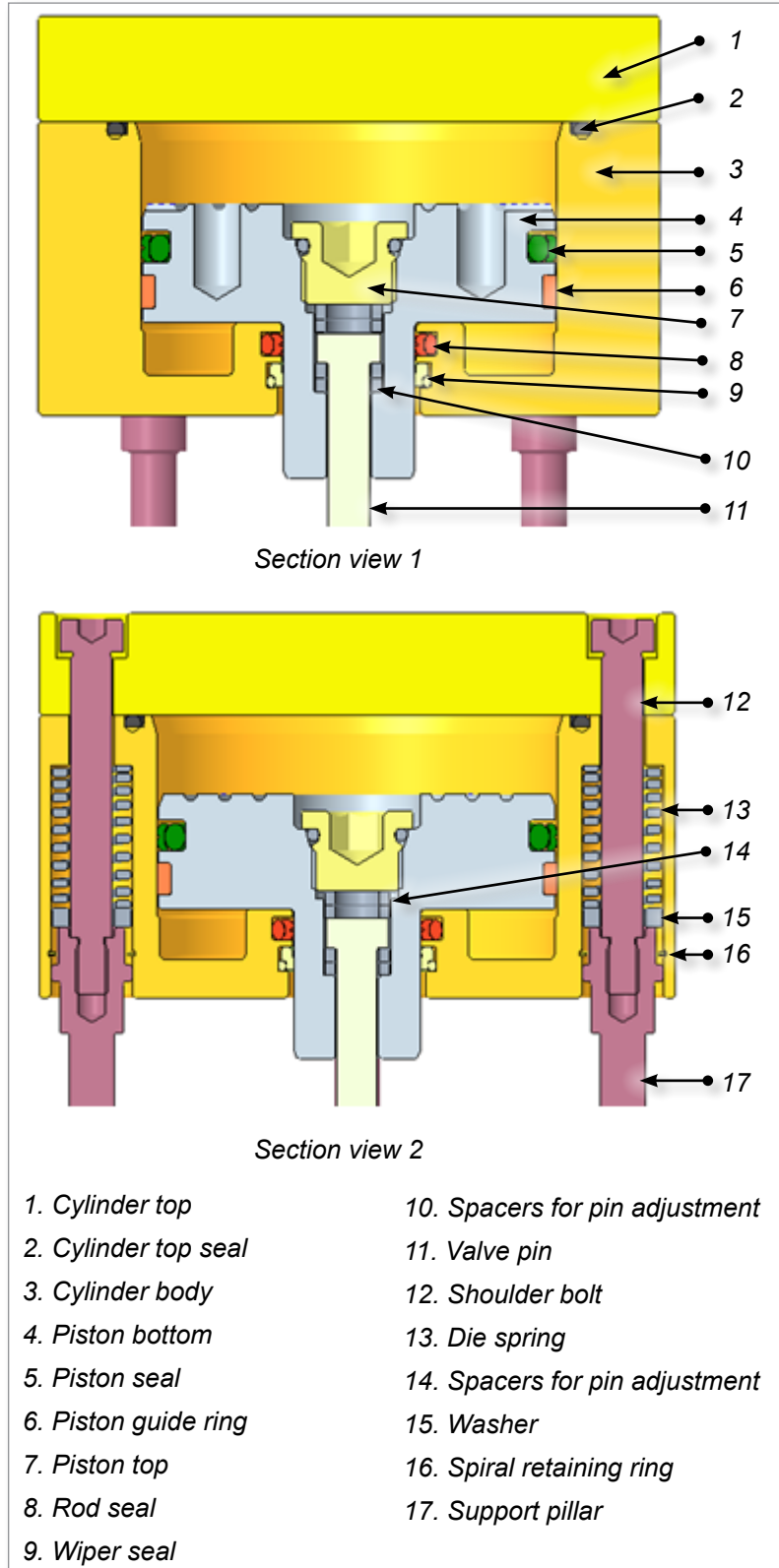

Figure 4-10 Components of the waterless pneumatic actuator

4.8.1 Assemble the Piston

1. Install the two piston seals and the piston guide ring. See Figure 4-11.

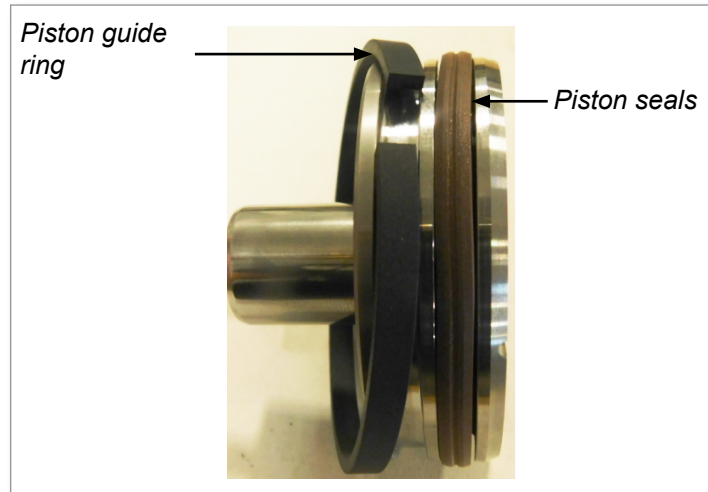

Figure 4-11 Install piston seals and guide ring

2. Install valve pin spacers (thickness = 2.1 mm and 2.2 mm) into the piston bore.
3. Insert valve pin.
4. Install the remaining two valve pin spacers (thickness = 2.0 mm and 2.3 mm) on top of the valve pin. See Figure 4-12.

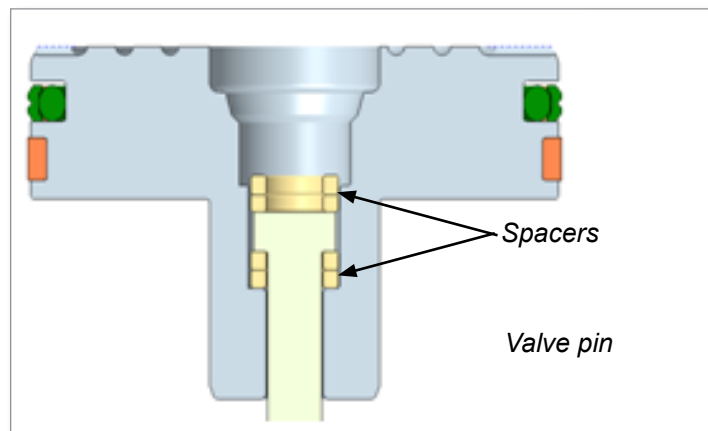

Figure 4-12 Install valve pin and spacers

5. Install the piston top.



CAUTION

Make sure that the O-ring is in good condition.

- Tighten the piston top to a torque of 10 Nm (7 lb-ft).



CAUTION

Use a soft jaw vise with the piston body to prevent damage to the part.

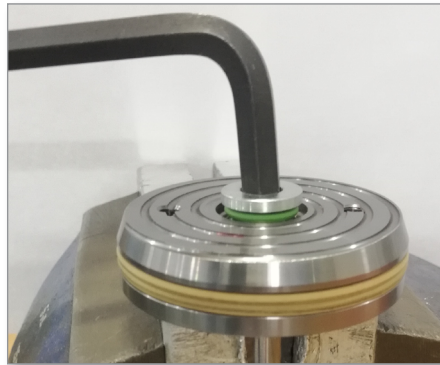

4.8.2 Adjust the Valve Pin Length (Optional)



WARNING

Surfaces may retain heat. Always use personal protective equipment.

This procedure is optional for situations in which the valve pin length requires adjustment.

- Check the required adjustment of valve pin length in hot condition.
- Cool down the system to room temperature, between 10°C and 40°C (50°F and 104°F), and remove valve pin from piston.
- Refer to the following table to choose the correct spacer combination for the length adjustment.

Table 4-3 Valve Pin and Spacer Combinations					
Valve Pin Length	Valve Pin Adjustment	Under Pin Head		Above Pin Head	
		Spacer Combination	Total Thickness	Spacer Combination	Total Thickness
Shorten (pin too long)	-0.20	A and C	4.40	A* and C*	4.20
	-0.10	C and D	4.50	A* and B*	4.10
Nominal	0.00	B and C	4.30	A* and D*	4.30
Lengthen (pin too short)	+0.10	B and D	4.20	B* and D*	4.40
	+0.20	A and B	4.10	C* and D*	4.50
*A thickness = 2.00 mm			*C thickness = 2.20 mm		
*B thickness = 2.10 mm			*D thickness = 2.30 mm		

4.8.3 Assemble the Cylinder Body

1. Insert die spring into cylinder body bore hole.

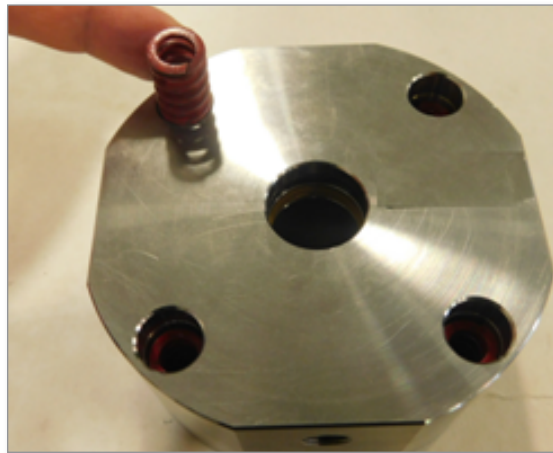

2. Insert washer into bore hole.

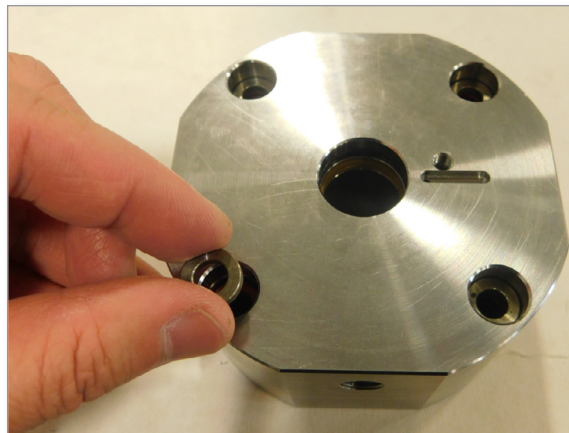

3. Assemble spiral retaining ring.
 - a) Deform the clip and press into bore hole.



b) Push down with a $\text{Ø}12.0$ mm rod.

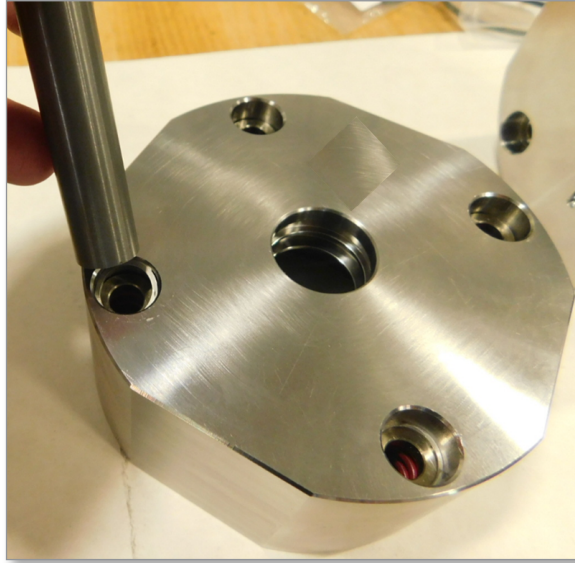

4. Install the O-ring for the rod seal. See Figure 4-13.



Figure 4-13 Install O-ring for rod seal

5. Install the rod seal. See Figure 4-14.



Figure 4-14 Install rod seal

See Figure 4-15 for an image of the completed assembly.

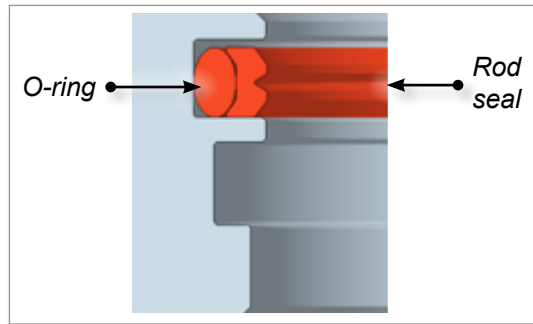

Figure 4-15 Rod seal assembly

6. Use the piston to push the seal into position.
7. Install the O-ring for the wiper seal. See Figure 4-16.



Figure 4-16 Install O-ring for wiper seal

8. Install the wiper seal. See Figure 4-17.



Figure 4-17 Install wiper seal

9. Use the piston to push the seal into position.
See Figure 4-18 for an image of the rod seal and wiper seal assemblies.

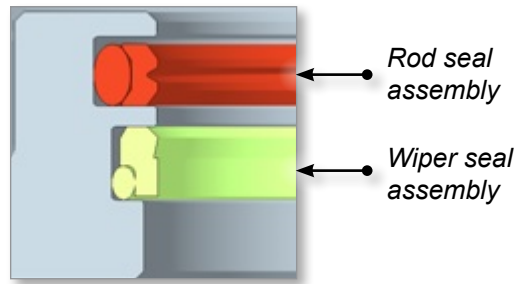

Figure 4-18 Rod seal and wiper seal assemblies

4.8.4 Assemble the Cylinder

1. Insert the piston into the cylinder body. See Figure 4-19.



Figure 4-19 Install the piston

2. Install the cylinder top seal. See Figure 4-20.

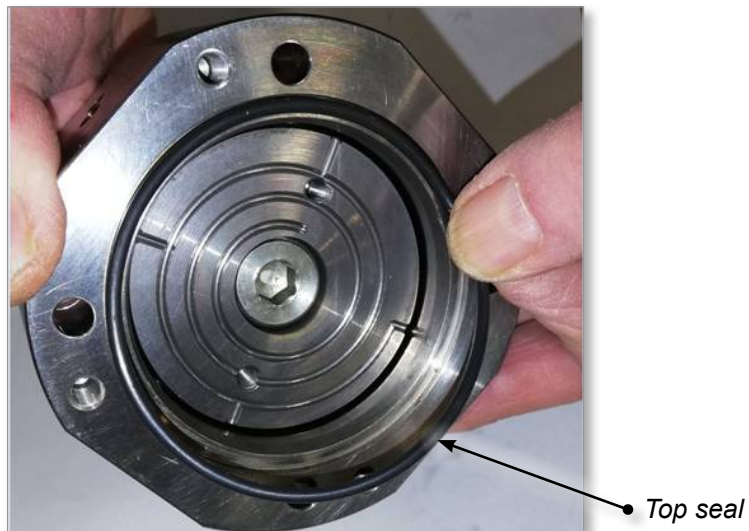

Figure 4-20 Install the top seal

3. Install the cylinder top onto the cylinder body.



NOTE

Ensure the ports are on the same face. See Figure 4-21.

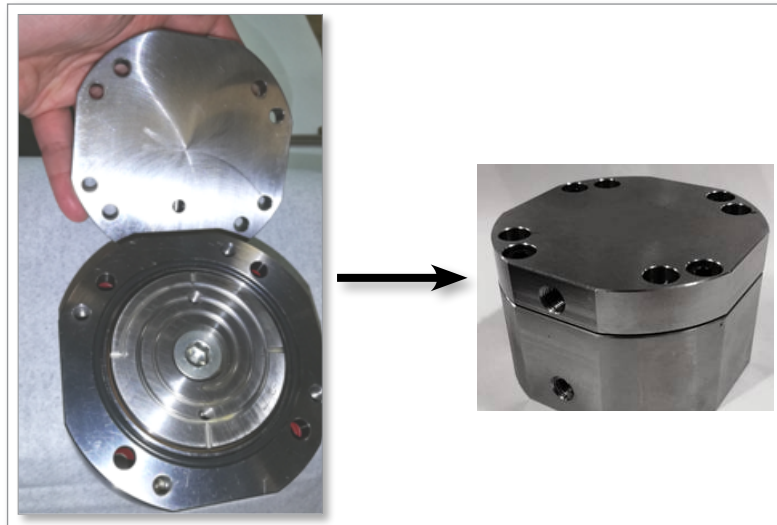
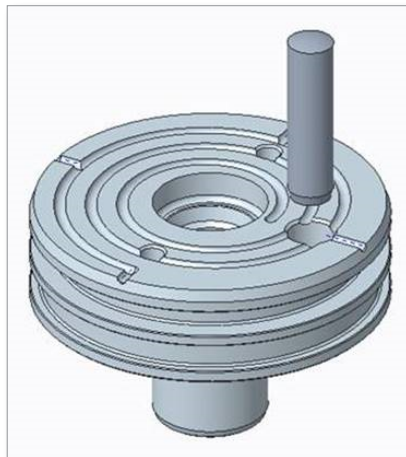

Figure 4-21 Assembled cylinder - note ports

4. Apply anti-seize compound to the screws.
5. Install the cylinder top screws.
6. Torque to 16 Nm (11.8 ft-lbs).

4.9 Assemble the Anti-Rotation Piston of the Ø63 mm Assembly

1. Insert the dowel pin into a liquid nitrogen bath.
2. Insert the dowel pin into the piston.



3. Install the two piston seals and the piston guide ring. See Figure 4-22.

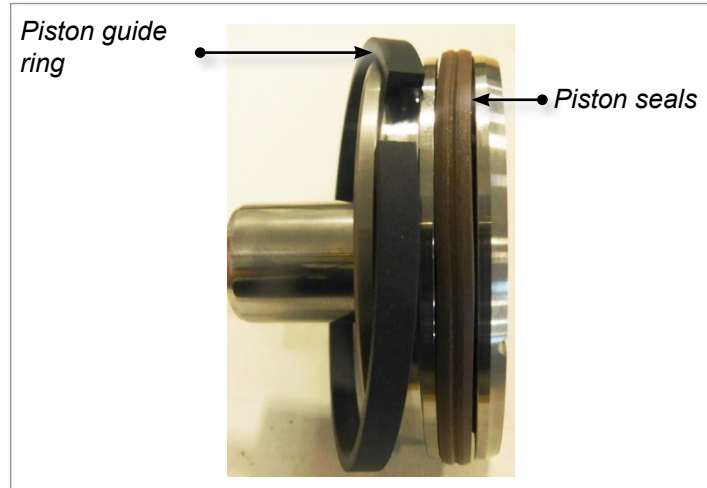

Figure 4-22 Install piston seals and guide ring

4. Install the valve pin spacers (thickness = 2.1 mm and 2.2 mm) into the piston bore.
5. Insert the valve pin.
6. Install the remaining two valve pin spacers (thickness = 2.0 mm and 2.3 mm) on top of the valve pin. See Figure 4-23.

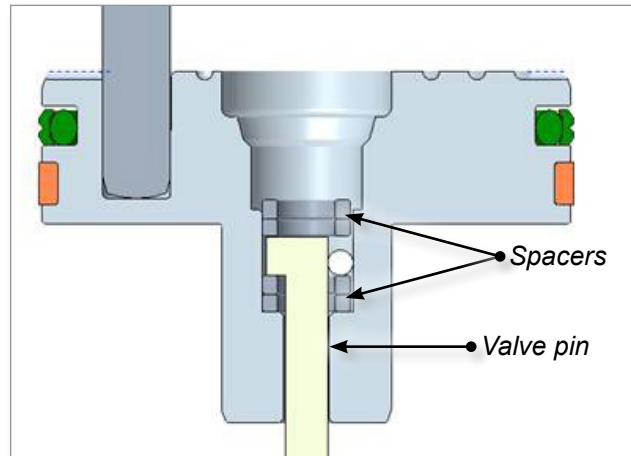

Figure 4-23 Install valve pin and spacers

7. Install the piston top.



NOTE

Make sure that the O-ring is in good condition.

8. Insert the piston with the anti-rotation dowel into the cylinder body. See Figure 4-24.

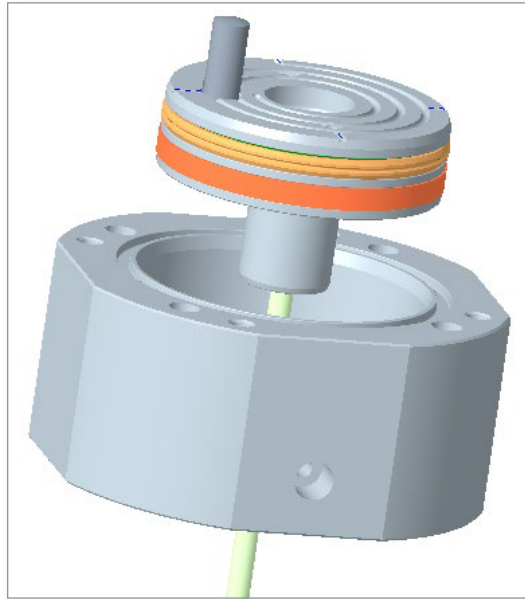
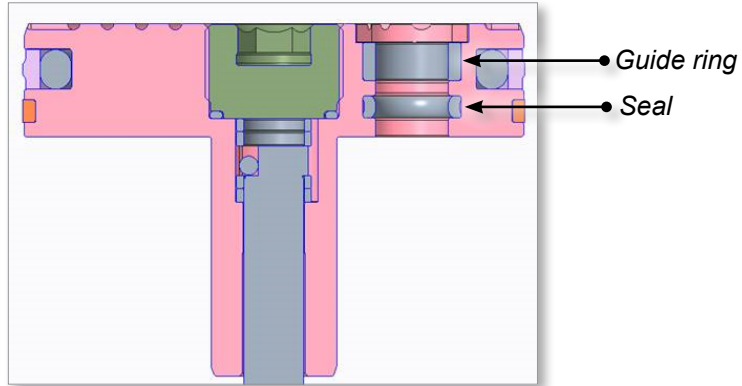

Figure 4-24 Anti-rotation version: install the piston

4.10 Assemble the Anti-Rotation Piston for the Ø80 mm Assembly

1. Do the steps in section section 4.8.1 Assemble the Piston on page 4-25.
2. Install the seal and the guide ring into the anti-rotation bore.



3. Apply Loctite 425 blue to a flat head screw (FHSM4X8).
4. Install the cover plate using the flat head screw. Tighten the flat head screw to a torque of 4.27 N·m (3.15 ft-lbs.).



5. Insert the bonded seal into the cylinder body.

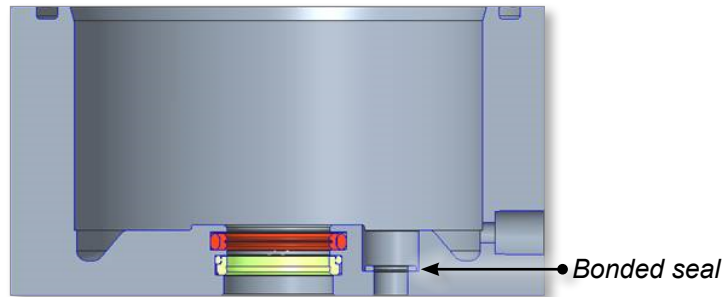

6. Insert the anti-rotation dowel into the cylinder body.



7. Install a socket head cap screw (SHCSM6x16). Use your fingers to tighten the screw.

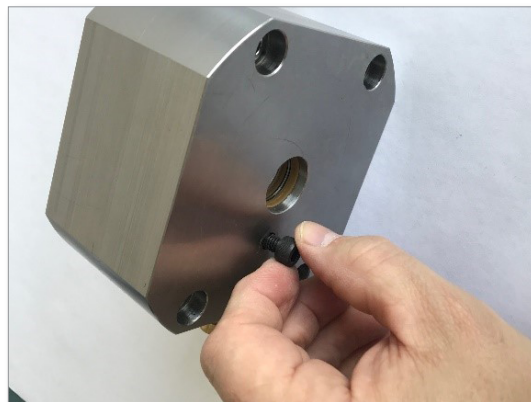

8. Insert the piston assembly into the cylinder body.

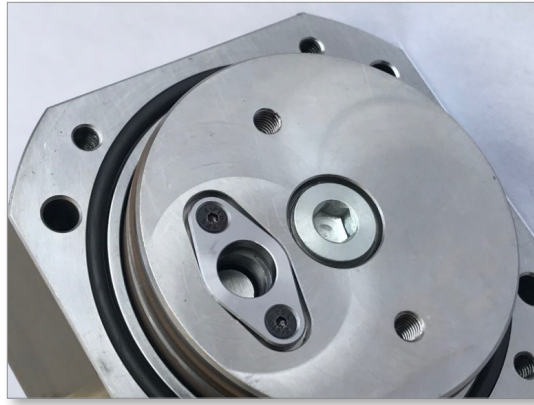

9. Tighten the socket head cap screw to a torque of 16 N·m (11.8 ft-lbs).

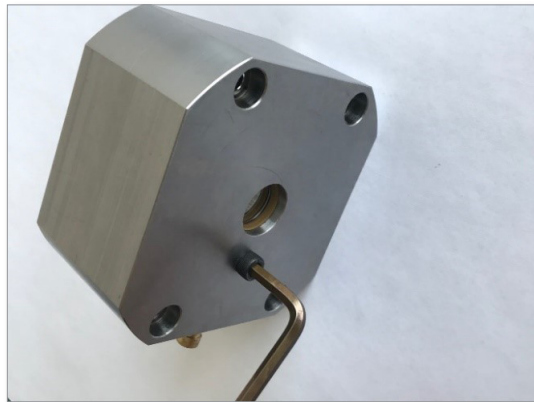

4.11 Assemble the Cylinder for the Ø63 mm and Ø80 mm Anti-Rotation Waterless Assemblies

1. Install the top seal of the cylinder.



2. Install the cylinder top onto the cylinder body with the dowel in the piston aligned with the anti-rotation slot. Make sure that the ports are on the same face.

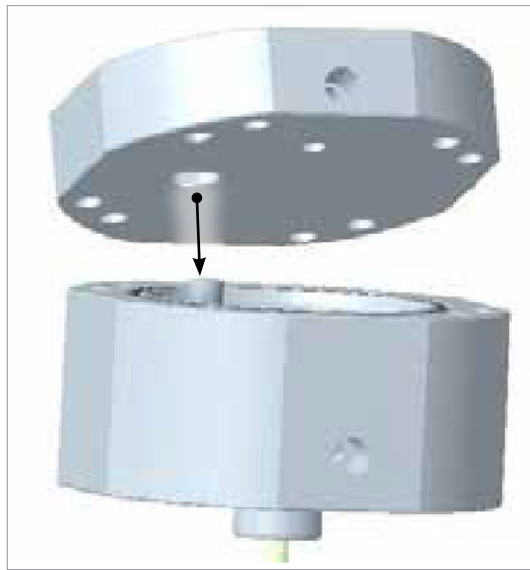

3. Apply anti-seize compound to the screws.
4. Install the screws in the top of the cylinder.
5. Tighten the screws to a torque of 16 N·m (11.8 ft-lbs).

Section 5 - Assembly



WARNING

Ensure that you have fully read “Section 3 - Safety” before assembling your Fusion Series system.

5.1 Typical Fusion-Series Systems

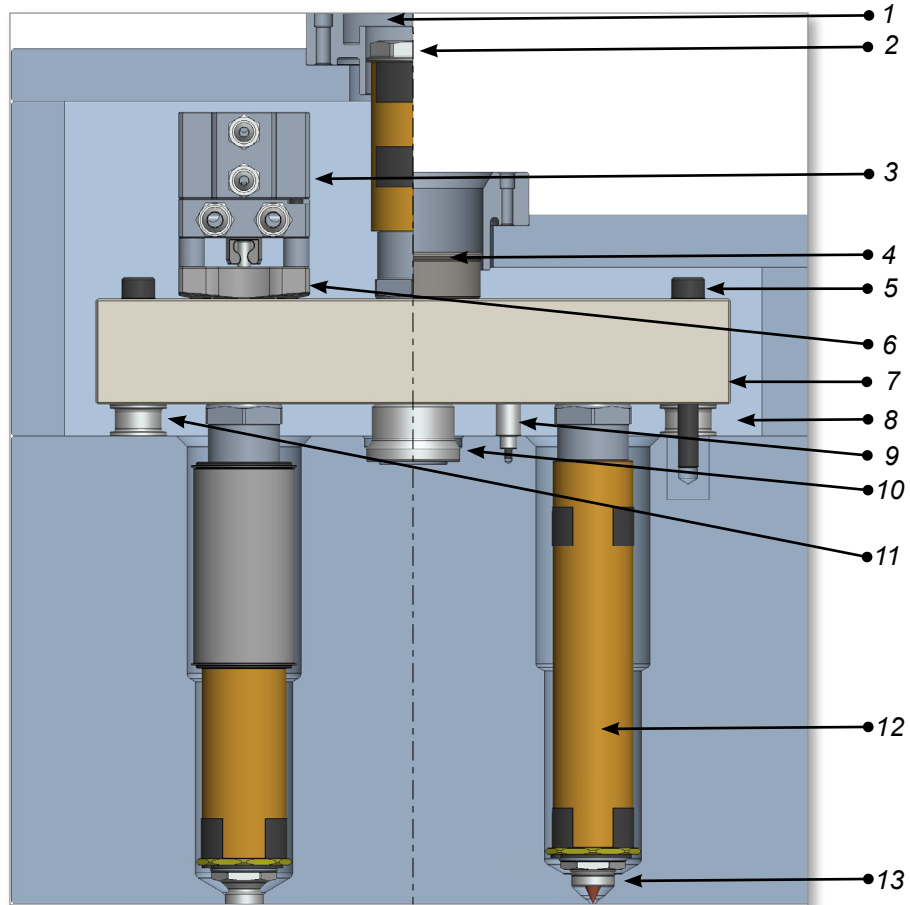

Figure 5-1 Fusion-Series G3 system with thread nozzle. Shown with protective sleeve (left half). Shown without protective sleeve (right half)

- | | |
|---------------------------------|------------------------|
| 1. Locating ring | 7. Manifold |
| 2. Inlet extension | 8. Air gap |
| 3. Valve actuator | 9. Anti-rotation dowel |
| 4. Back plate | 10. Manifold locator |
| 5. System screw | 11. Support bushing |
| 6. Valve disk / Insert assembly | 12. Nozzle |
| | 13. Gate seal |

5.1.1 Fusion-Series G3 Drop-In System

System will be fully assembled and ready for installation

- Wire channel for wiring protection and hoses support
- Pre-wiring with electrical box or panel
- Pre-plumbing: all water cooling hoses and actuator oil / air hoses
- Adapter plates for external fitting connection
- Optional solenoid valvebank connection

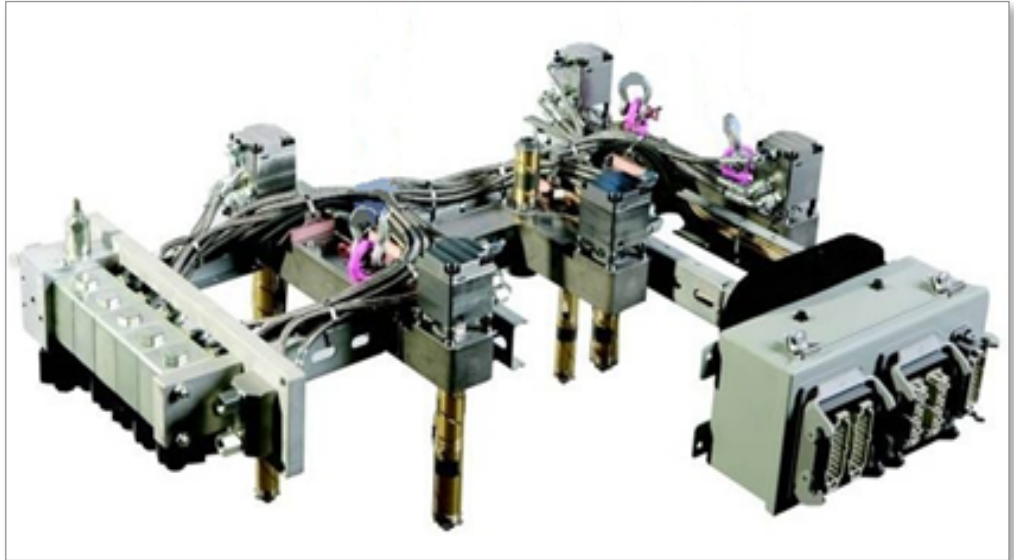

Figure 5-2 Fusion Series drop-in system

5.1.2 Fusion Series Lite System

Hot Runner system will be pre-assembled, however,

- No wire channel, adapter plate and E-Box
- No wiring and no plumbing
- No fittings

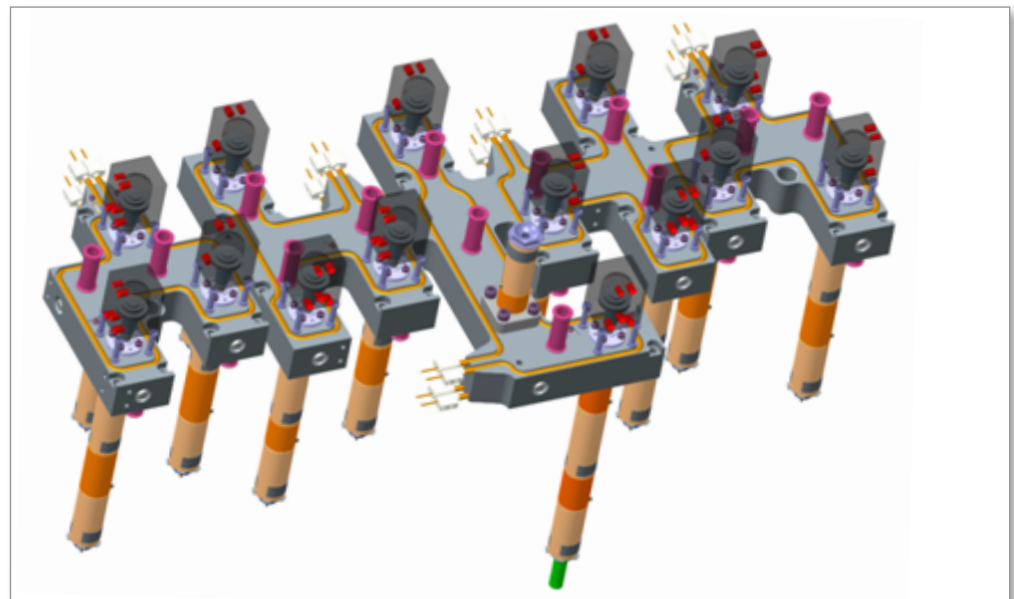

Figure 5-3 Fusion Series lite system

5.2 Gate Seal Finishing

Most nozzles are supplied with the gate seal installed (except when the seal requires final machining by a toolmaker, such as the Hot Valve / Hot Sprue).



NOTE

The gate seals supplied with your system may need to be adjusted to tolerances based on the material grade and cooling in the cavity. Refer to your *Mold-Masters* General Assembly Gate Detail drawing to determine if gate seal finishing is required. Refer to the General Assembly drawing to determine which gating method applies.

5.2.1 Hot Valve / Hot Sprue / F Type



CAUTION

Protect the thermocouple so it is not damaged during machining.



NOTE

Heat expansion of the nozzle must also be taken into consideration.

Contour of gate seal should be done at process temperature.

Always refer to the General Assembly drawing to confirm the contact length.

Hot valve and hot sprue gated systems are supplied with gate seals that are oversize in length. They must be machined prior to installing the nozzle into the nozzle well bore. Check the chart on the General Assembly drawings for the length and contact height required.

See Contact Length "H" on table below.

Table 5-1 Typical Contact Length	
Polymer Structure	Contact Length "H" in mm (in.)
Amorphous Filled or Reinforced	4.00 (0.16)
Semi-crystalline Filled or Reinforced	3.00 (0.12)
Crystalline Filled or Reinforced	2.00 (0.08)

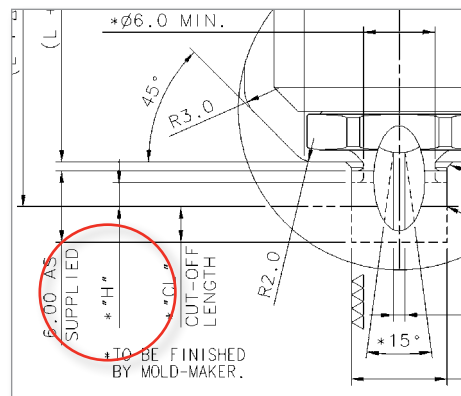

Figure 5-4 Example contact length "H"

5.3 Re-torque at Process Temperature



CAUTION

If nozzles and gate seals are not re-torqued at process temperature leakage could occur.

Once the system is assembled, nozzles and gate seals must be re-torqued at process temperature.

1. Set the temperature of all Hot Runner components to processing temperature according to the start up procedure.
2. Make sure all cooling lines other than the cover plate are connected properly.
3. After reaching the processing temperature let the system 'soak' at that temperature for at least five minutes.
4. Re-torque nozzles and gate seals to recommended torque values in section 11.1 Recommended Torque Settings on page 11-1.

5.4 Check Nozzle Core to Manifold Fit

5. Inspect threads for burrs.



6. Apply die spotting blue compound to nozzle core.



Check Nozzle Core to Manifold Fit - continued

7. Apply anti-seize compound to threads.



8. Assemble nozzle to manifold and torque to specified value.



9. Verify transfer of die spotting blue compound from nozzle core to manifold.

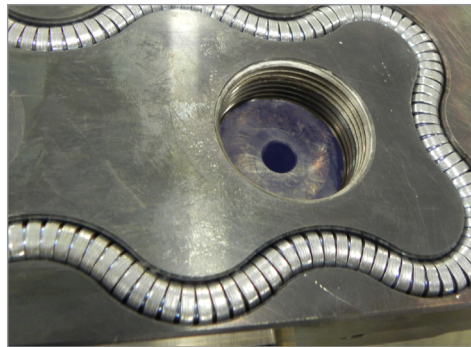

10. Clean die spotting blue compound from components.



5.5 Assemble Nozzle to Manifold

11. Apply anti-seize compound to the nozzle threads.



12. Assemble the nozzle to the manifold.

13. Torque the nozzles to value on the General Assembly drawing.



IMPORTANT

Remember to re-torque at process temperature when system assembly is complete.

5.6 Nozzle Assembly for Systems with Protective Sleeves

Mold-Masters recommends the use of protective sleeves with Fusion Series nozzles.

For systems without protective sleeves, please see section 5.7 Nozzle Assembly for Systems without Protective Sleeves on page 5-12.

1. Install the bottom end cap of the protective sleeve onto the coredel.

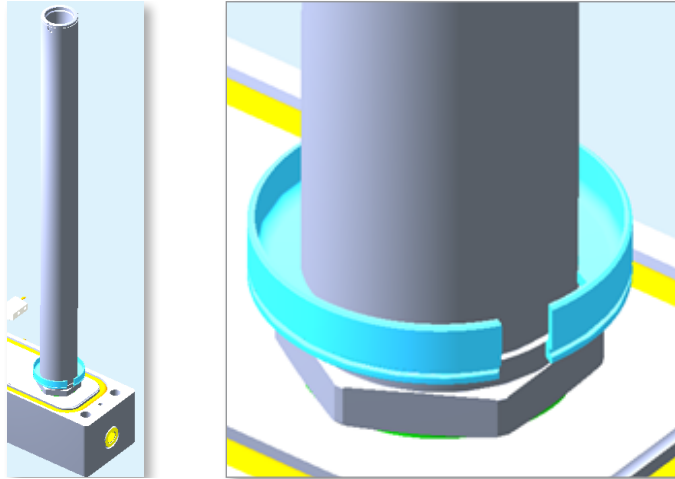

2. Install the rear heated sleeves and the unheated sleeves onto the nozzle core. (Refer to your system **GA drawings** for the installation order of heated and unheated sleeves.)

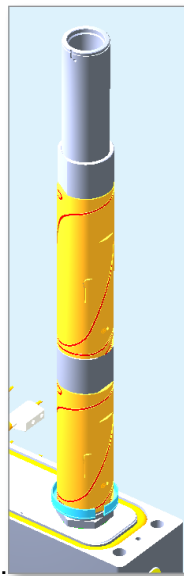

**Nozzle Assembly for Systems with Protective Sleeves -
continued**

3. Install the second end cap of the protective sleeve before the front heated sleeve.

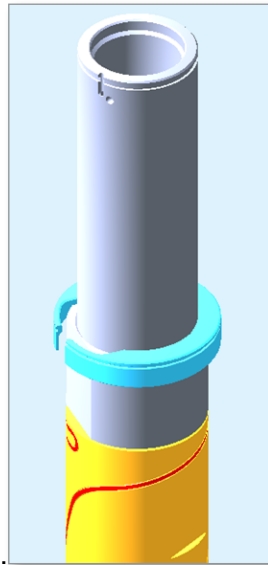

4. Install the front heated sleeve and make sure that the M3 thread hole is aligned with the dimple of the core.

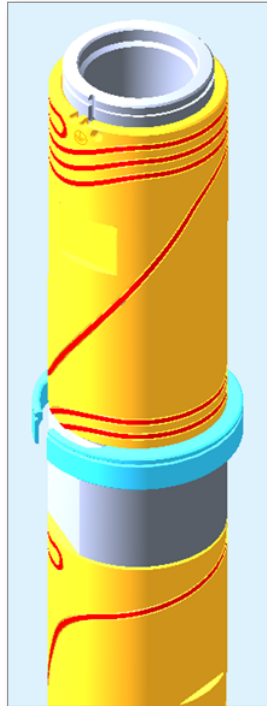

5. Install thermocouples (TC's) into the TC slots and place TC clips (except the front TC clip) to secure them in position.

**Nozzle Assembly for Systems with Protective Sleeves -
continued**

6. Tighten all the extended wires of thermocouples and heaters through the cuts of the end caps.

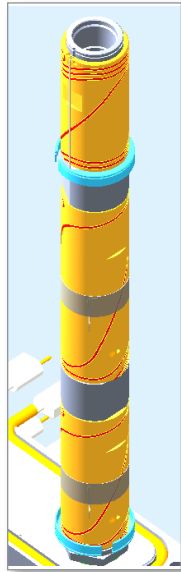

7. Apply a retaining ring as a stopper onto the bottom end cap.

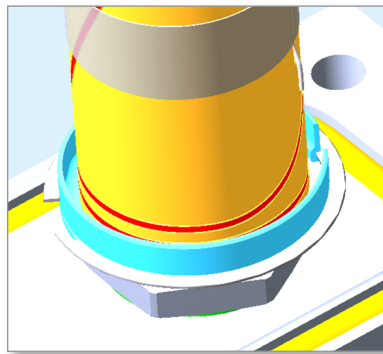

8. Slide the rear protective sleeve between the top and bottom end caps.

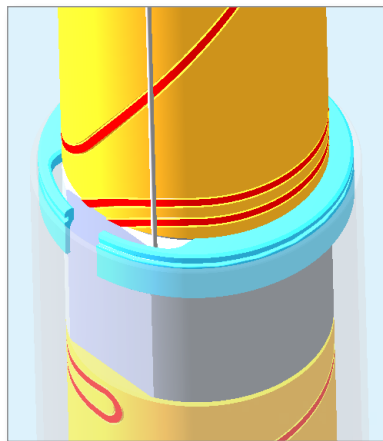

9. Apply a retaining ring as a stopper onto the top end cap.

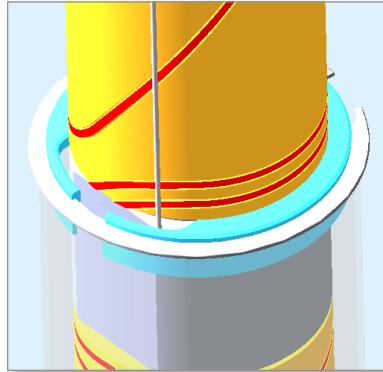

10. Install the front protective sleeve and align it with the thermocouple.

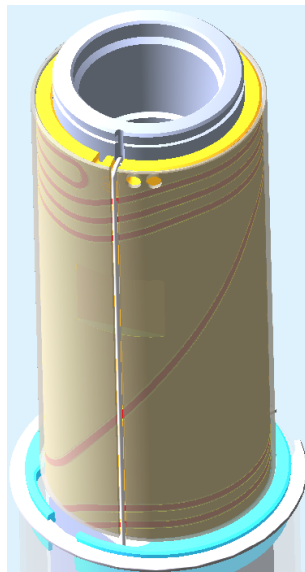

11. Insert an M3 set screw and a TC clip to secure the positions of the thermocouple, protective sleeve, and front heated sleeve.



12. Install a centering guide ring.

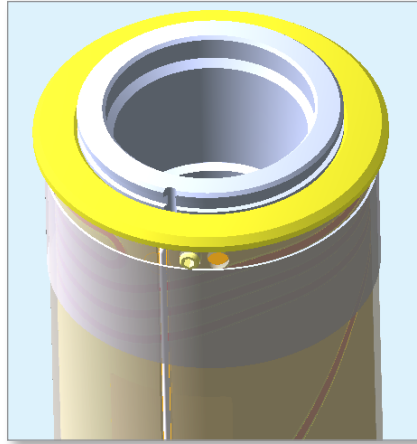

13. Install a retaining ring onto the core.

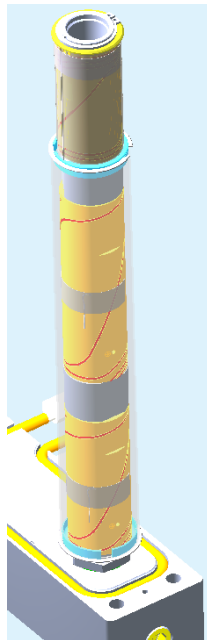
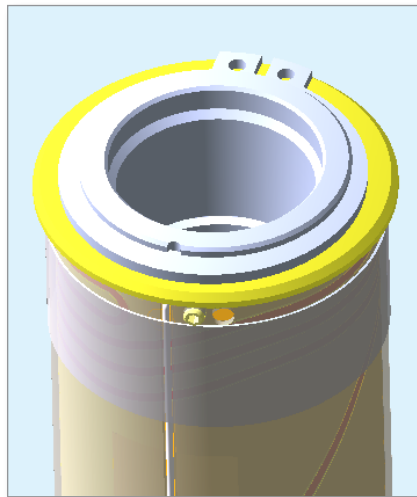
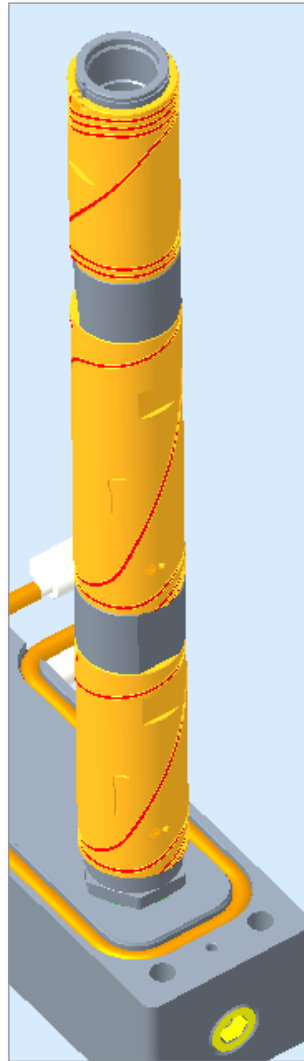

Figure 5-5 Completed nozzle

5.7 Nozzle Assembly for Systems without Protective Sleeves

1. Install the heated and unheated sleeves as instructed in the installation order on your system GA drawing.



2. Install an M3 set screw to properly align the front heater sleeve.

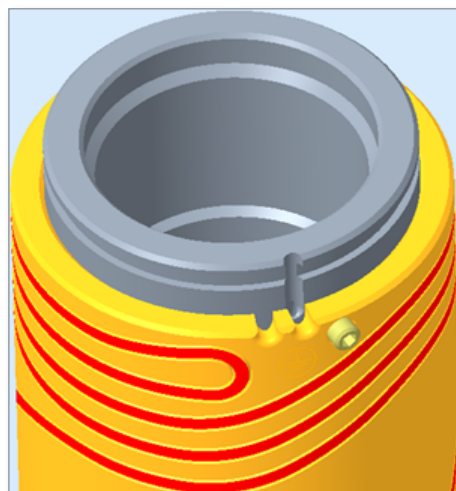

3. Install thermocouples in the thermocouple slots until they reach the bottom of the slot.

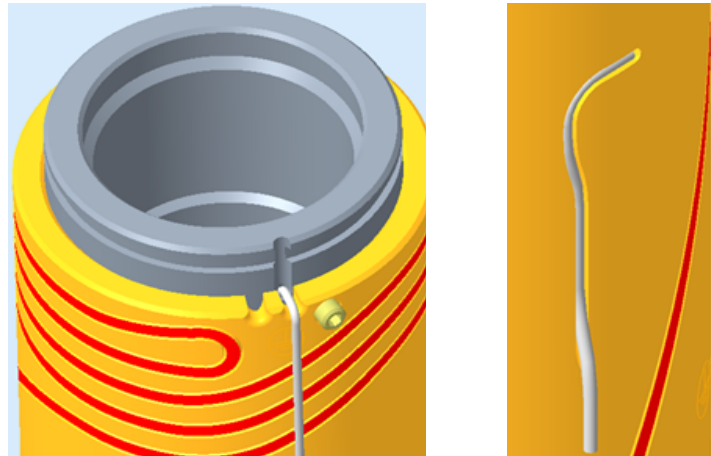

4. Install the thermocouple clips.

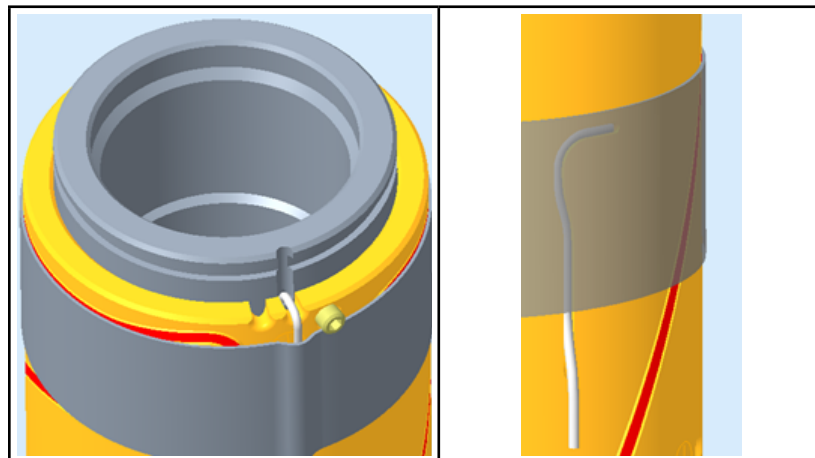

5. Install the centering guide ring.

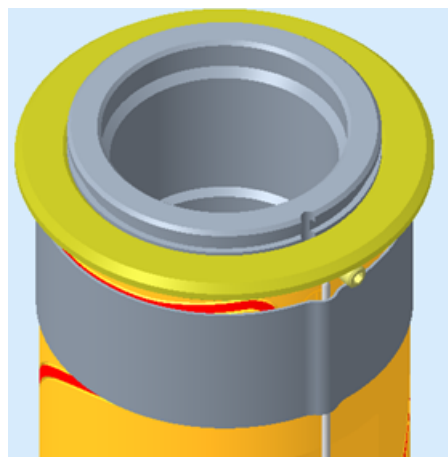

6. Install a retaining ring in the core.

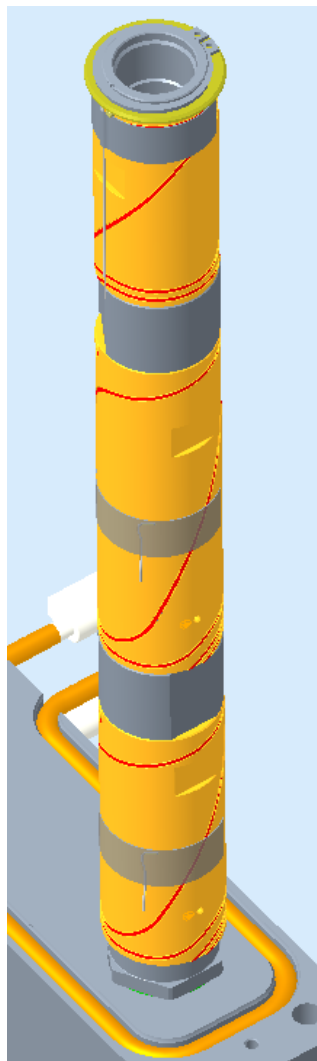
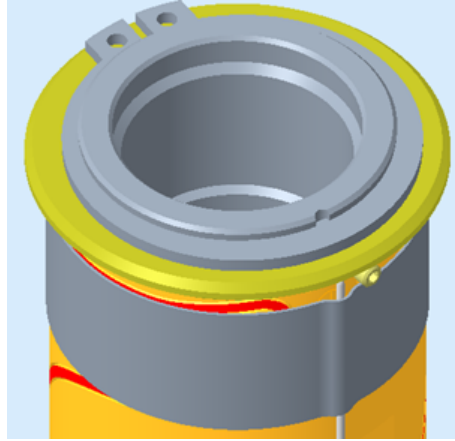

5.8 Gate Seal and Nozzle Assembly

5.8.1 Check Gate Seal to Nozzle Fit

1. Apply die spotting blue compound to the gate seal and gate seal liner (if relevant).



2. Torque the gate seal to specified value.

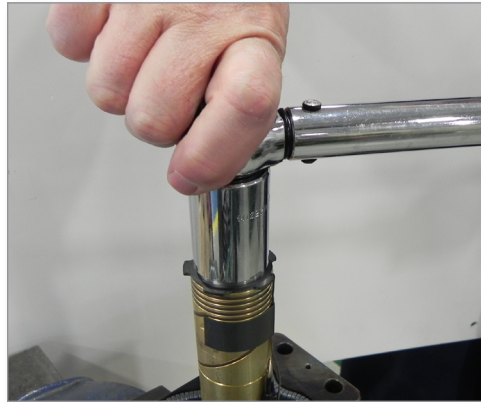

3. Remove gate seal and verify transfer of die spotting blue compound from gate to the liner. Verify transfer of die spotting blue compound to nozzle core. If not 100% blue on face, contact your *Mold-Masters* representative.
4. Clean die spotting blue compound from components.

5.8.2 Install Gate Seal on Nozzle

1. Apply anti-seize compound to all threaded interfaces.
2. Ensure all sealing surfaces are clean and dry.
3. Install the gate seal and liner.

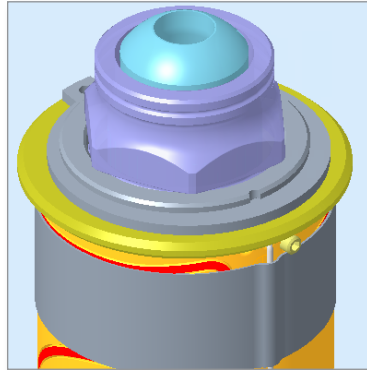

4. Torque to specified values. Remember to re-torque at process temperature when system assembly is complete.

5.9 Install Manifold Locator

1. Apply anti-seize compound to socket head cap screws.
2. Install the manifold locator to the manifold and torque the screw to the specified value. See section 11.1 Recommended Torque Settings on page 11-1.



3. Verify the height of the manifold locator to the dimension specified on the General Assembly drawing.

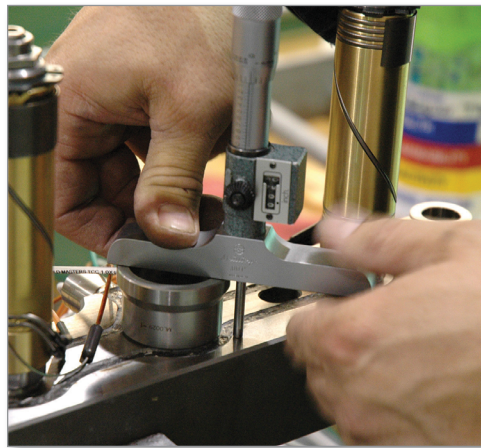

5.10 Install Support Bushings

4. Apply anti-seize compound to the screw.



5. Install the support bushing to the manifold and torque the screw to specified value.

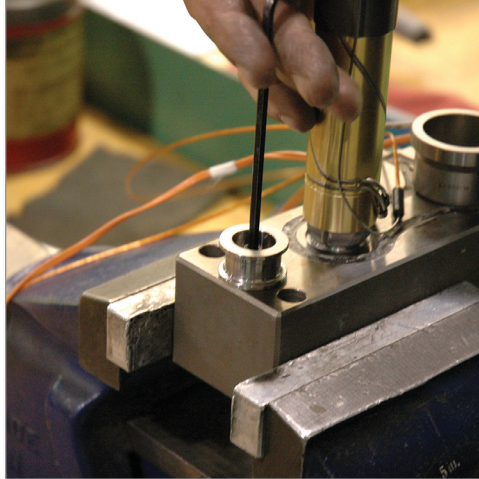

6. Repeat for the other support bushings. Typical application will require one support bushing per nozzle.



7. Verify the height of the support bushing and the manifold locator to the specification on the General Assembly drawing.

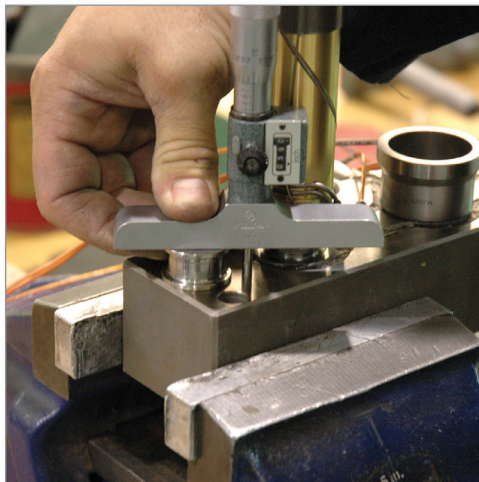

5.11 Install Manifold Thermocouple

1. Ensure the thermocouple holes in the manifold are clean and free of blockage.

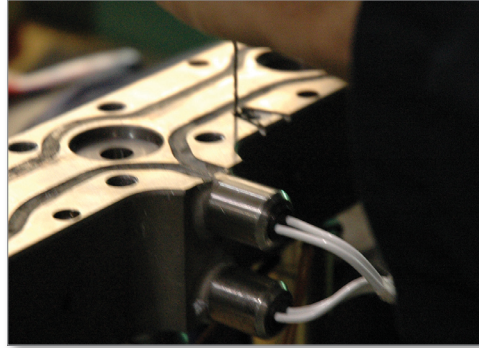

2. Install the manifold thermocouple into the manifold thermocouple hole until it bottoms out in the hole. Repeat for all manifold thermocouples.

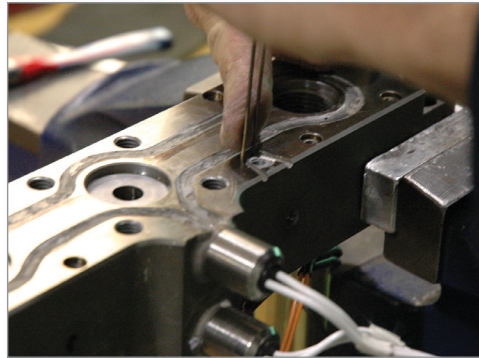

3. Bend the thermocouples into the slot.

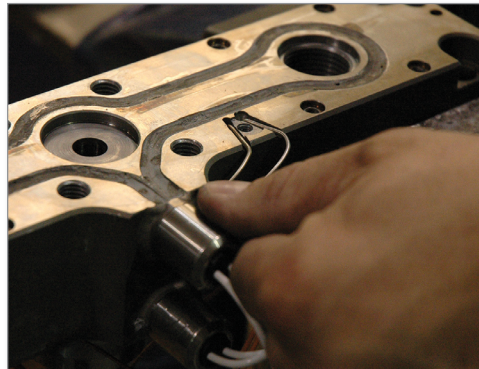

4. Install the manifold ground strap and the thermocouple retention screw combination.

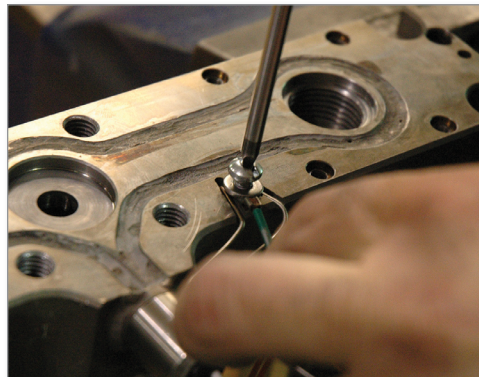

5.12 Install Inlet with Flange

There are nozzle coredels that are used as inlet extensions for F5000, F6000 and F8000 series. Each one can be installed with or without a flange.

1. Clean and inspect the manifold bore and inlet bottom.



CAUTION

The nozzle coredel must protrude from the flange a minimum of 0.25 mm.

2. Pre-assemble (hand tighten) the nozzle coredel and flange.
3. Apply die-spotting blue compound to the bottom of the inlet.

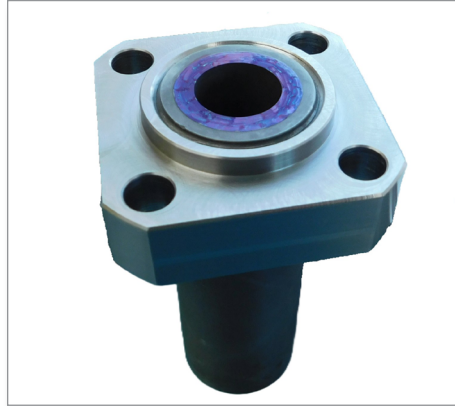

4. Apply anti-seize compound to the screw.
5. Install the inlet in the manifold.



6. Tighten the screws in a crisscross pattern, gradually increasing torque to the specified value.



7. Remove the inlet to verify blued surfaces. If the face is not 100% blue, contact your Mold-Masters representative.

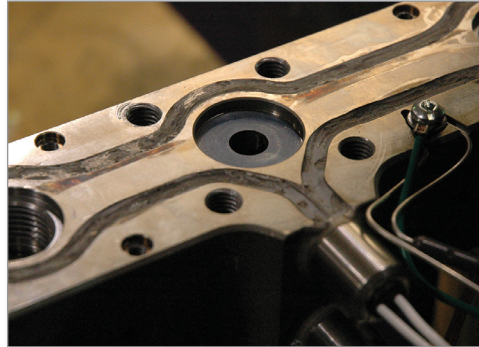

8. Clean the die-spotting blue compound from the inlet and the manifold.
9. Re-install the inlet. Torque screws in a crisscross pattern, gradually increasing the torque to the specified value.



10. Install the inlet heater and sleeve. Make sure that the terminal end connection is facing in the correct direction.

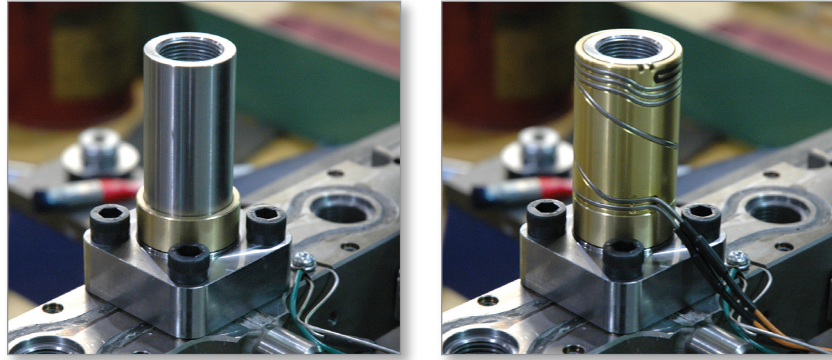

5.12.1 Install Inlet Thermocouple

1. Install the thermocouple in the slot until it reaches the bottom of the slot.



2. Bend the thermocouple 180 degrees.
3. Install the thermocouple clip.



5.12.2 Install Inlet Extension Tip

1. Apply die-spotting blue compound to the inlet extension tip.
2. Install the inlet extension in the inlet.
3. Verify blued surfaces to check for a correct fit.



4. Clean the die-spotting blue compound from the inlet extension tip and the inlet.

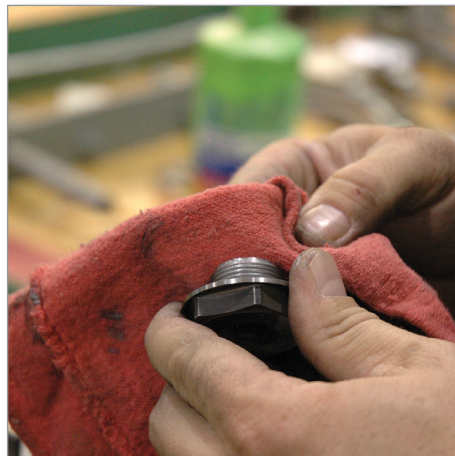

5. Apply anti-seize compound to the threads
6. Install the inlet extension tip in the inlet.

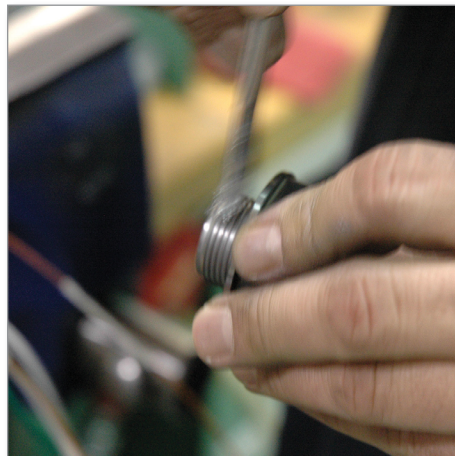

7. Tighten to the specified torque value.

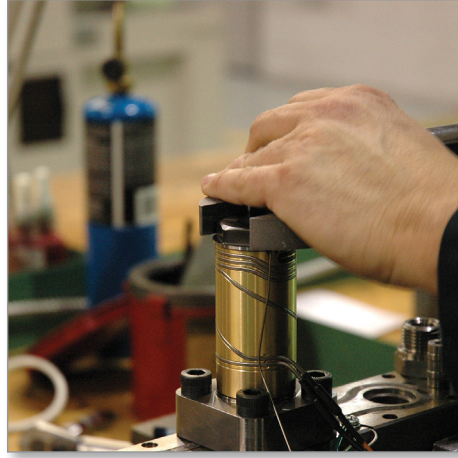

5.13 Install Inlet Extension without Flange

5.13.1 Check Inlet Extension Coredel to Manifold Fit

Complete the instructions in section section 5.4 Check Nozzle Core to Manifold Fit on page 5-4.

5.13.2 Install Nozzle Heaters and Sleeves

1. Install heaters and sleeves per specified drawings.



5.13.3 Install Inlet Thermocouple

Complete the instructions in section section 5.12.1 Install Inlet Thermocouple on page 5-22.

5.13.4 Install Inlet Extension Tip

Complete the instructions in section section 5.12.2 Install Inlet Extension Tip on page 5-23.

5.14 Install the Valve Insert or Valve Disk (VD)

5.14.1 Install the Valve Insert (Valve Insert Design)



NOTE

The valve pin is guided by the valve insert which is locked by the valve flange and four bolts.

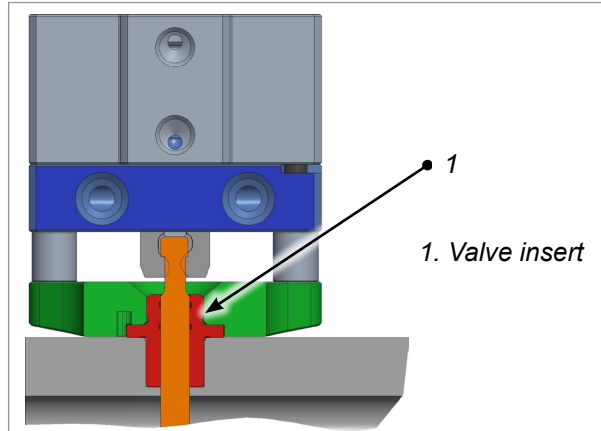

NOTE

Valve inserts and VD stems are made from the same blanks and are held down by the same VD flanges.

1. Verify that the height of the valve insert and the depth of manifold bore match the dimensions specified in the General Assembly drawing.
2. Apply blue die-spotting compound to the contact surfaces of the valve insert.

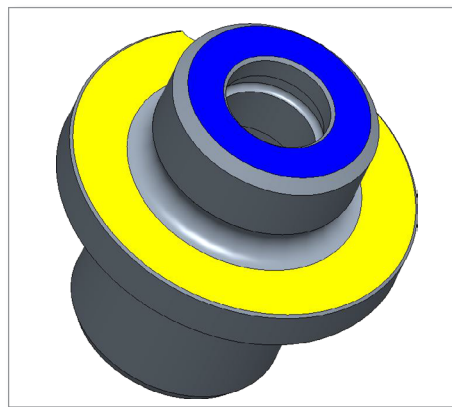

3. Apply anti-seize compound to the screws.
4. Install the screws in a crisscross pattern.
5. Remove the valve insert, and verify that there is blue die-spotting compound on all contact surfaces.
6. Clean the blue die-spotting compound from all components.
7. Install the valve insert and tighten in a crisscross pattern.
8. Install the valve pin to verify fit.

5.14.2 Install the Valve Disk (Valve Disk Design)

1. Apply blue die-spotting compound to the valve disk stem.

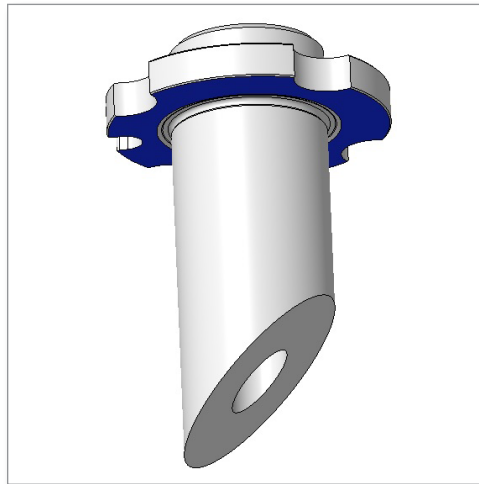

2. Install the valve disk stem in the manifold hole.

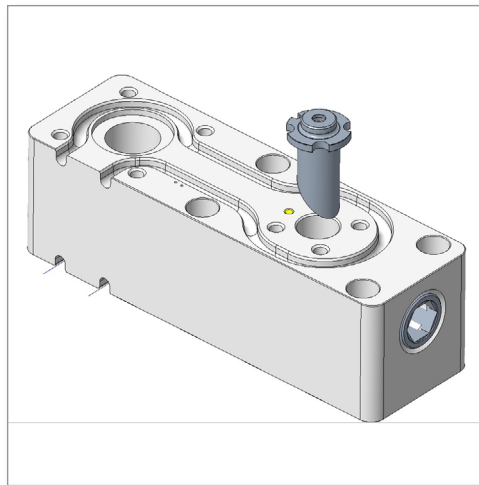

3. Install the valve disk flange on top of the valve disk stem.

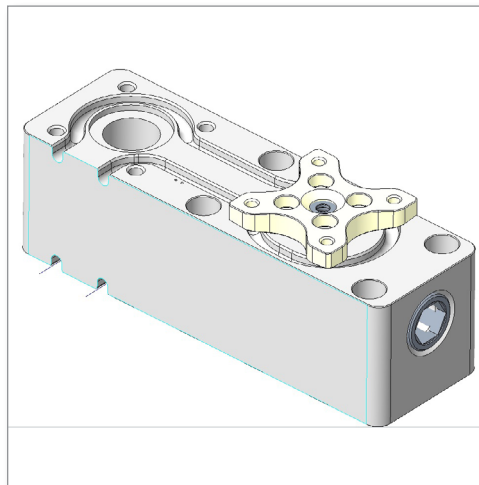

4. Install the screws and tighten the screws to the specified torque value.

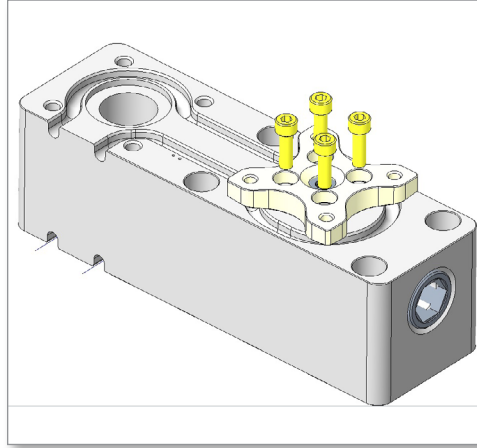

5. Remove the valve disk stem and verify that there is blue die-spotting compound on the contact surface.
6. Clean the blue die-spotting compound from all components.
7. Re-install the valve disk stem and the valve disk flange. Tighten the screws in a crisscross pattern.

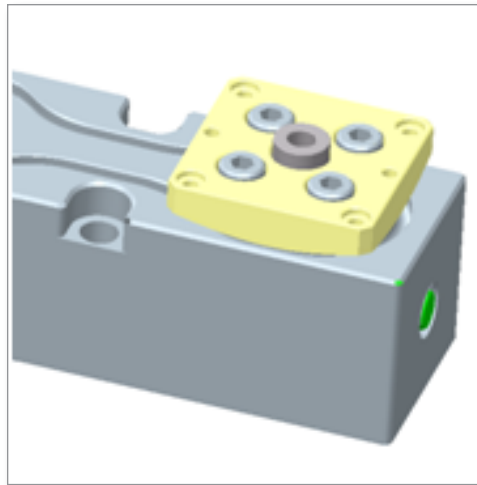

8. Install the valve pin to verify fit.

5.15 Install the Cylinder on the Manifold

1. Install the valve pin in the valve disk stem.

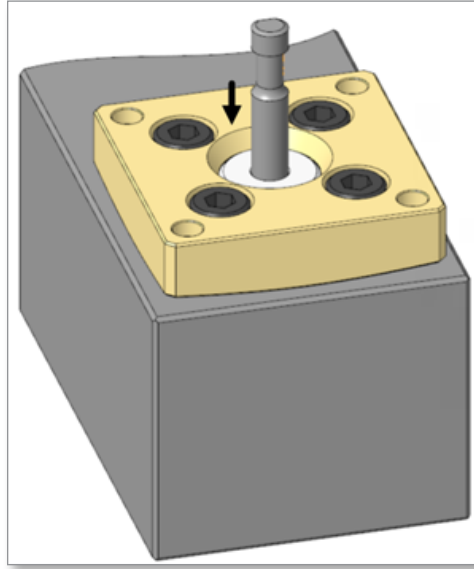

2. Align the actuator and the valve pin.

For 5.0 and 6.3 mm valve pins, align the lower slot to the lower lip of the piston bottom.

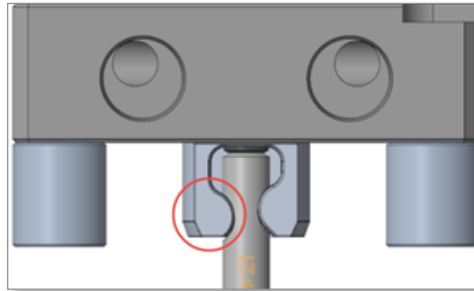

For 3.0, 8.0 and 9.5 mm valve pins, align the flat to the corresponding piston bottom flat.

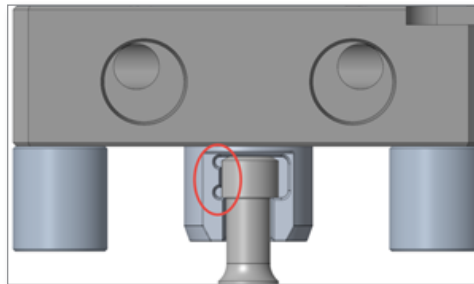

3. Slide the actuator on top of the valve pin through the piston-bottom valve-pin slot.

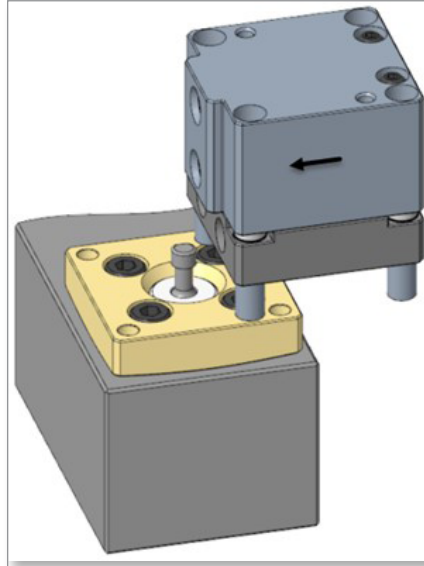

4. Apply anti-seize compound to the shoulder screws.
5. Locate and tighten the actuator using the shoulder screws.
6. Gradually tighten the shoulder screws in a criss-cross pattern.

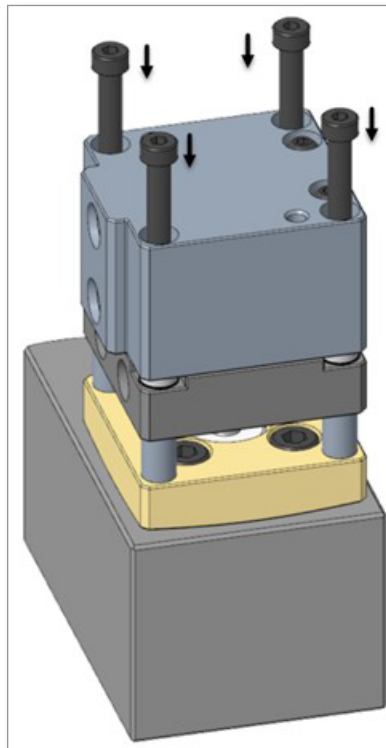

7. Connect air or oil and cooling water hoses as per your system design.

5.16 Tapered Valve Pins



WARNING

Wear personal protective equipment when doing the following tasks. Failure to do so may cause injury or death.

5.16.1 Find the Current Lap

1. Use a black marker to apply black ink to the tapered portion of the tapered valve pin.



2. Install the support bushing with the center hole matching the pin diameter.
3. Insert the tapered valve pin through the lapping bushing, and insert this assembly into the support bushing.



4. Rotate the tapered valve pin 10° in each direction while in contact with the gate. Do not turn the valve pin 360° as high spots in the gate will produce a false indication of the pin-to-gate contact.

5.16.2 Hone a Tapered Valve Pin



Figure 5-6 Honing and lapping kit



CAUTION

Do not use a power tool to do the honing. Using power tools will quickly wear out the hone, roll a large burr into the cavity, and potentially enlarge the gate size.

While doing the following steps, visually monitor the tapered seat in the tool steel. Clean the seat often with mineral spirits and blasts of air. Clean the hone every 30–60 seconds to ensure a clean cutting surface.

1. Use a 400 grit hone to manually hone the gate.
2. Clean up the gate using a 600 grit hone.

5.16.3 Lap a Tapered Valve Pin

The support bushing must be installed with the center hole matching the pin diameter.

1. Install the valve pin through the lapping bushing.



2. Add 400 grit lapping paste to the tapered part of the tapered valve pin.



3. Lap the pin into the gate.



4. Remove all lapping paste from the valve pin
5. Apply 600 grit lapping paste to the tapered part of the tapered valve pin.
6. Lap the pin into the gate.
7. Remove all lapping paste from the valve pin and cavity before assembling the actuator.



8. Install the nozzle.
9. Install the manifold.

5.16.4 Clean the Valve Pin and Runner

1. Remove all plastic from the nozzle, and clean the gate seal and liner.



2. Heat the manifold.

**WARNING**

Hot surface. Do not touch. Contact may cause burns.

3. Remove all plastic from the runner bore by using needle nose pliers and blowing air onto the plastic being removed.

4. Check whether the valve pin slides into and out of the runner smoothly. If the valve pin does not slide smoothly into and out of the runner, repeat step 3.

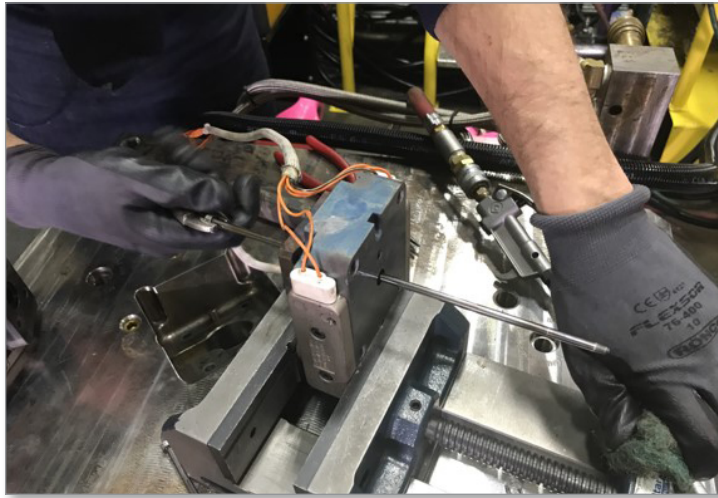

5. Using an abrasive pad (Scotch pad, for example), clean the residue from the tapered valve pin as you slide the tapered valve pin into and out of the runner. The tapered valve pin should slide smoothly into and out of the valve disk.

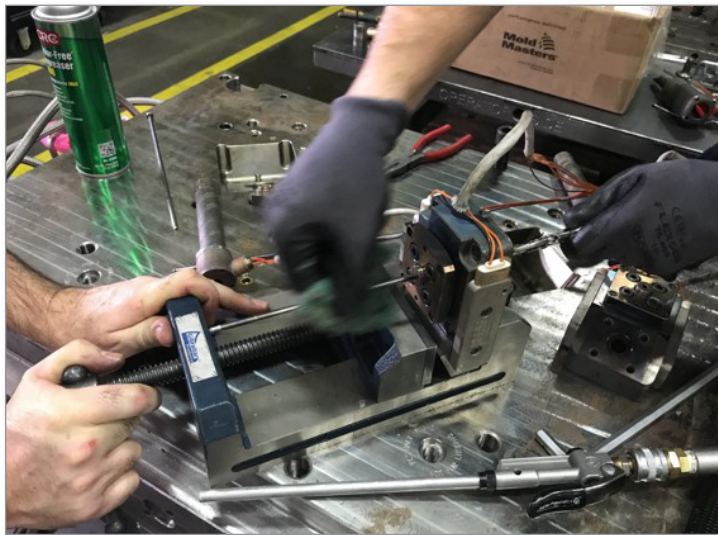

6. Install the nozzle.
7. Install the manifold.

5.16.5 Calculate the Preload of a Valve Pin (Timing the valve pin)

1. Remove the valve pin and spring pack from the piston.
2. Install the actuator on the manifold.
3. Install the piston in the actuator. Make sure that the piston is pushed all the way down.



4. Use a depth micrometer to measure the distance from the top of the actuator housing to the spring pack seat. Record this measurement as dimension A.
5. Remove the piston from the actuator.
6. Remove the rod seal from the actuator.
7. Push the valve pin down into the valve disk as far as possible.



8. Heat the manifold and nozzle zones to the set point and let soak for 15 minutes.



WARNING

Hot surface. Do not touch. Contact may cause burns.

9. Use a depth micrometer to measure the distance from the top of the actuator housing to the pin. Record this measurement as dimension B.
10. Calculate the preload using the equation: $Preload = A - B$.
11. Compare the calculated preload with the preload of your GA drawings.
 - a) If there is too much preload, grind back the angle of the valve pin, and redo the lapping. See section 5.16.3 Lap a Tapered Valve Pin on page 5-32 for instructions.
 - b) If there is insufficient preload, grind the underside of the valve pin head, and then weld material to the top of the valve pin to advance the valve pin.
12. Use pliers to remove the tapered valve pin, Make sure not to touch the cylinder walls and seals if any.

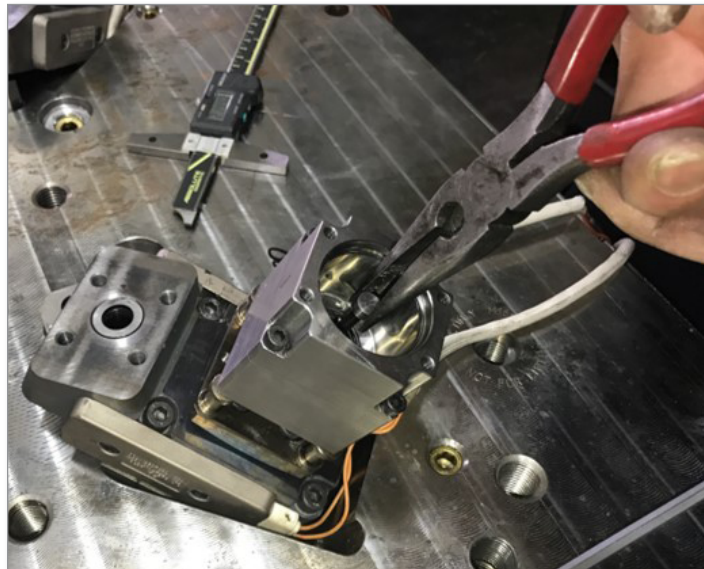

De-burring a Gate

During the honing and lapping processes, a burr in the edge of the tapered gate was probably rolled into the cavity. There can be no burrs inside or outside the gate area. A qualified toolmaker must remove all burrs. Mold-Masters technicians do not provide this service. To check for a burr, run a gloved finger over the gate from the parting line. To remove burrs, the valve pin, manifold system, and nozzle must be removed from the mold.

5.17 Waterless Hydraulic and Pneumatic Actuators



CAUTION

Make sure that a surface grinding of the contact surface of the top clamp plate is done. This keeps the waterless actuator operating at recommended temperatures.



CAUTION

Do not include waterless actuators in the hot runner assembly during high-temperature oven cleaning. This could cause permanent damage to the actuators' components.

1. Install the support pillars.

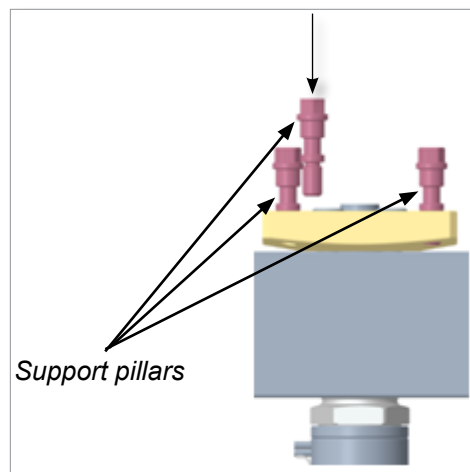

2. Tighten the support pillars to 20 Nm (14.8 ft-lbs).
3. Locate the actuator on top of the support pillars.

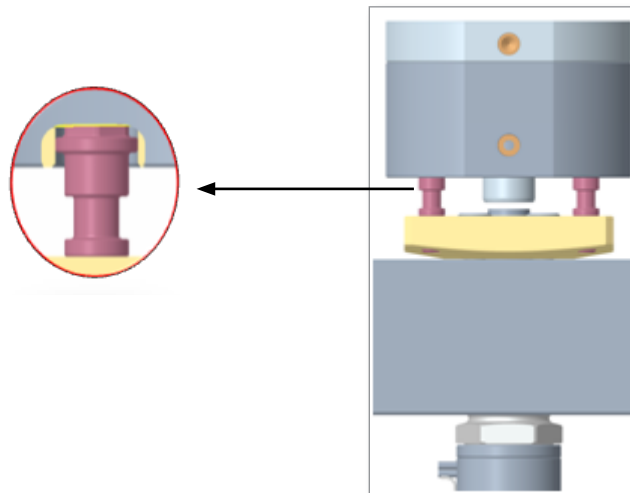

4. Apply anti-seize compound to the shoulder bolts.

5. Screw the bolts onto the support pillars through the cylinder body. Make sure the bolts are fully seated in the support pillars.

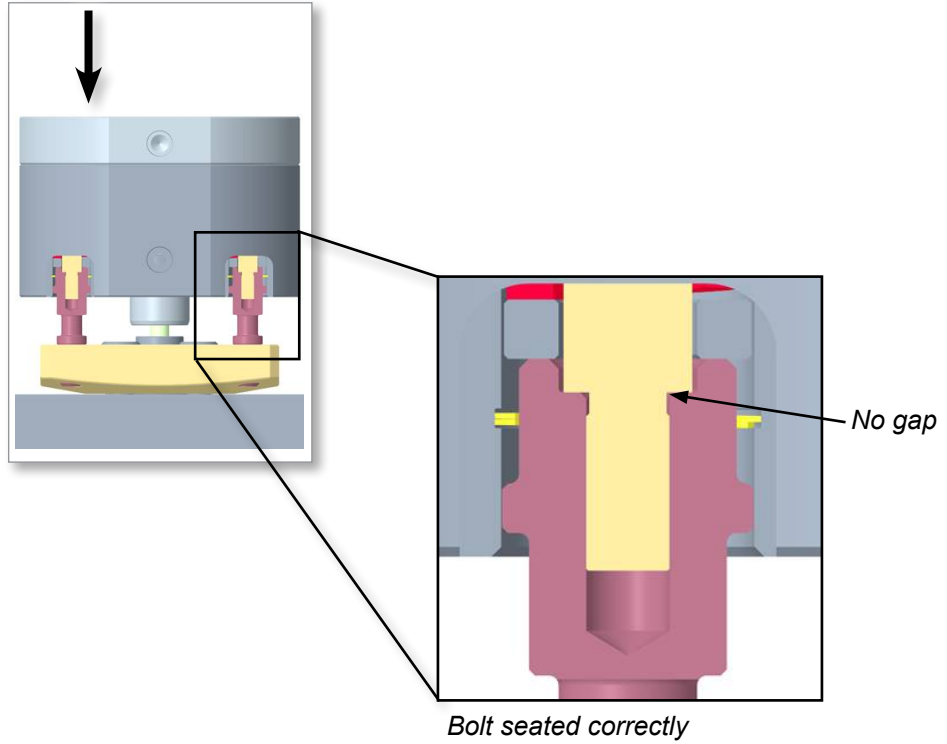

6. Tighten the shoulder bolts in a crisscross pattern. Gradually increase the torque to 9.5 Nm (7 ft-lbs).

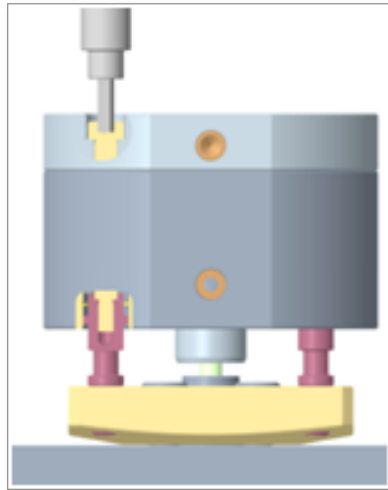

7. Manually push the cylinder down several times to ensure it bounces back freely to its original height.

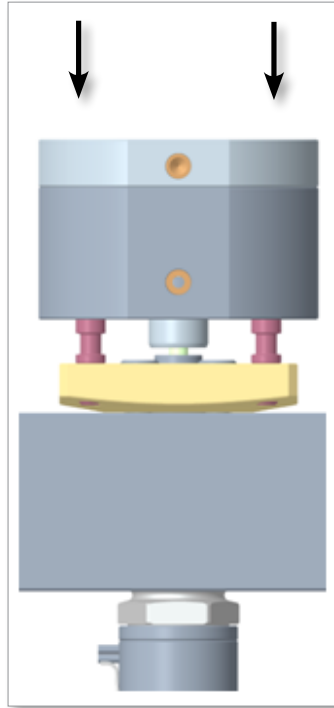

8. Confirm that the tooling pocket height and the actuator height meet design requirements as shown on the General Assembly drawing. See Figure 5-7.

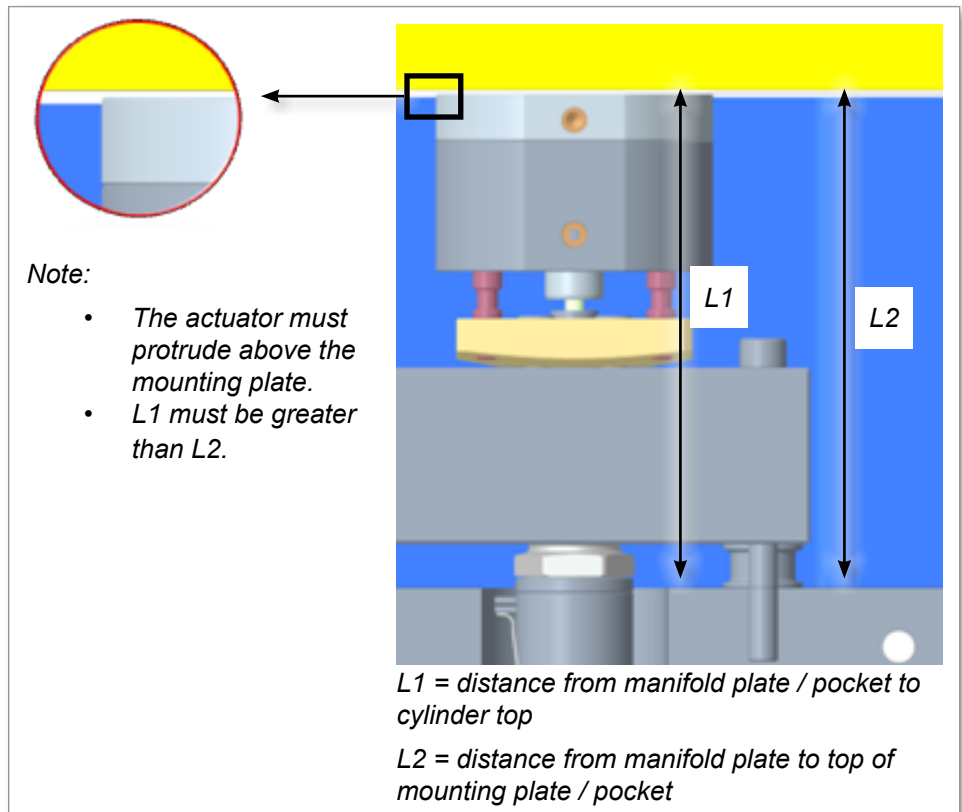

Figure 5-7 Check tooling pocket

**IMPORTANT**

The actuator **must** protrude above the top of the mounting plate. See Figure 5-7.

9. Bolt the clamp plate to the mounting plate.

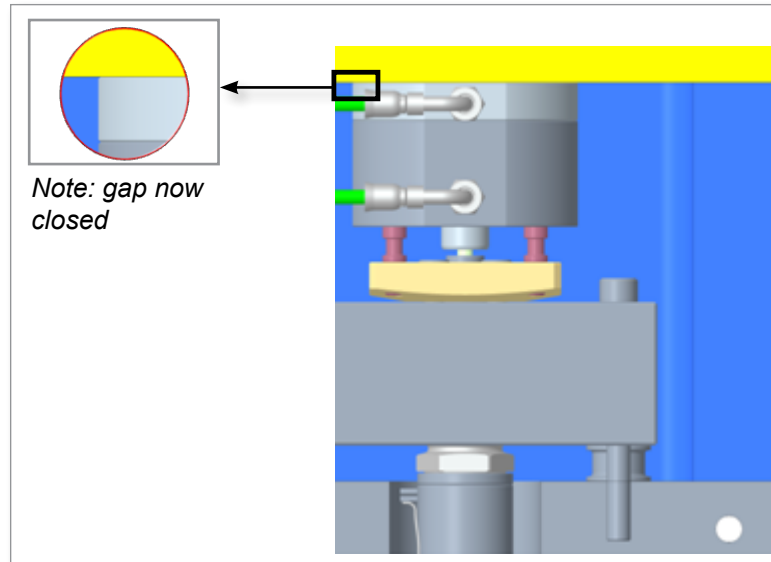

Figure 5-8 Bolt clamp plate

This action should press the cylinder down to close the gap. See Figure 5-8.

10. Tighten the bolts to the torque value specified on the General Assembly drawing.

5.18 Install the Wire Armor on the Manifold

1. Place the bracket insulation plate at the bracket location on the manifold.

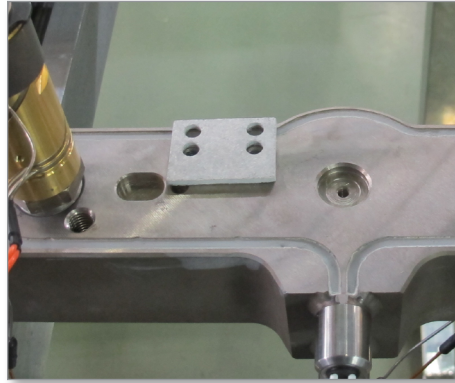

2. Apply anti-seize compound to the button head cap screws (BHCS). Using the BHCS screws install the bracket, over the insulation plate, in the appropriate location(s) on the manifold.

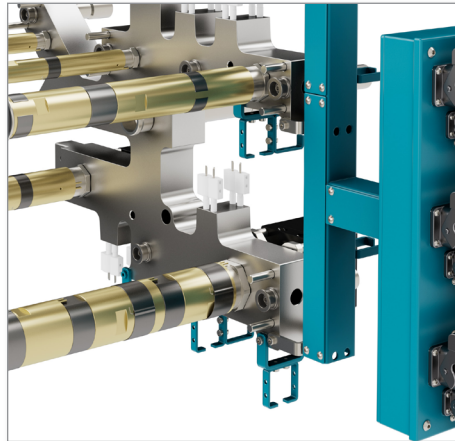

3. Mount the wire armor to the bracket.

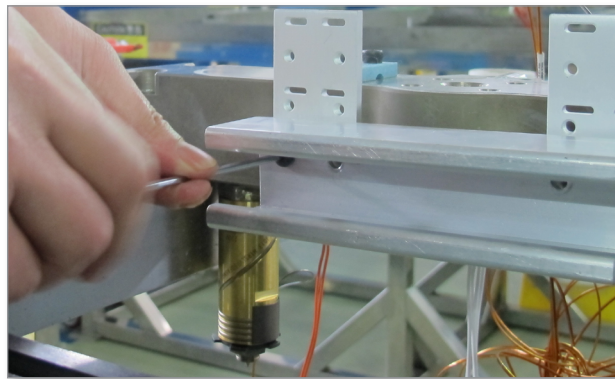

5.18.1 Install the Wiring

4. Group together the thermocouple and heater wires for a single zone. Label the heater and thermocouple zones. Install high temperature wire sheathing.



5. Feed the wiring through the wire armor and install the wire armor channel caps.



6. Repeat for all zones.

5.18.2 Electrical Routing into Electrical Box

1. Install thermocouple and heater wires into the electrical plugs according to the wiring schematic in MM General Assembly "EWS" drawing.



2. Install the plugs in the electrical box.

5.18.3 Solenoid Valve Wiring

1. Install the solenoid coil wires into the electrical plugs according to the wiring schematic.

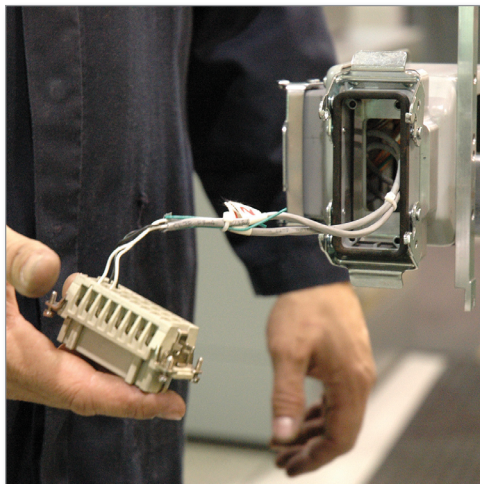

2. Install the plugs in the electrical box.

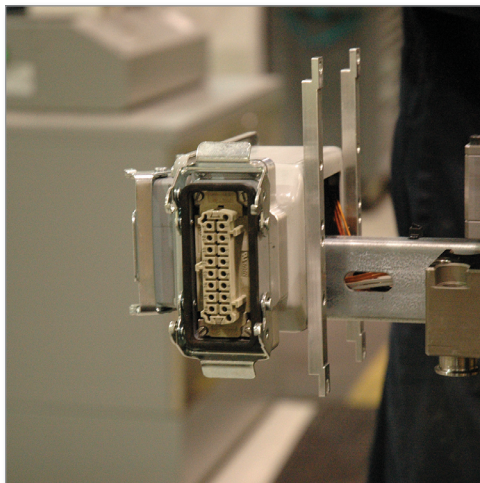

5.18.4 Plumbing Cylinders



NOTE

For ease of hose assembly, the cylinder top can be rotated 90 degrees in any direction.

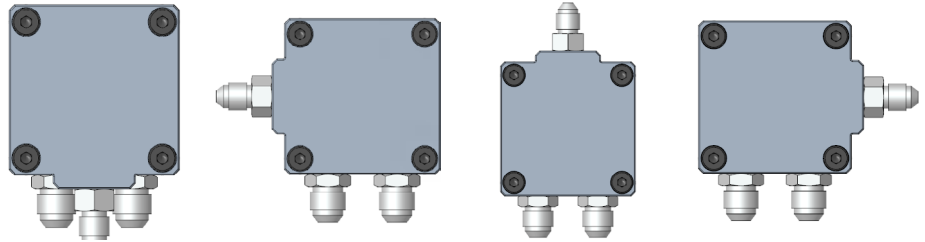

1. Connect the hoses to the actuators.
2. Label and group the hoses.



3. Route the hoses on top of the wire armor and secure with ties.



4. Connect the hoses to the adapter plate according to the drawing schematic.

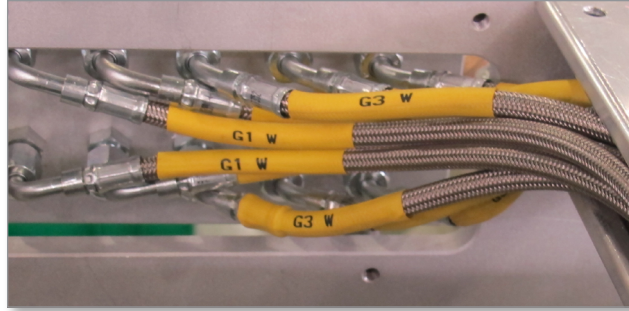

5.19 Connect the Solenoid Valve Bank

5.19.1 Hydraulic Valvebank Connection

1. If any of the provided hoses are longer than required then you must cut them to length and crimp the end onto the port union. Attach an appropriate label to show gate number (Gxx) and Open or Close function.
2. Prepare crimped hose with labeling and arrange the control layout to the solenoid valve bank.
3. Connect the hydraulic hose with the first white label "G1 CLOSE" to the port on the top of the cylinder.

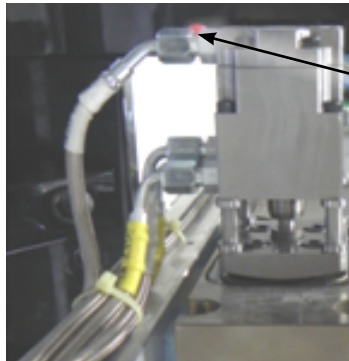

White "G1 Close" hoses go to the upper ports

4. Route the hose on top of the wire channel and secure with high temperature cable ties.
5. Connect the other end of the hose to the designated valve-unit port. On the Bosch Rexroth solenoid valve bank:
"B" port = CLOSE,
"A" port = OPEN

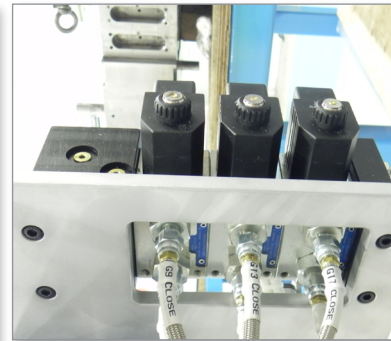

6. Continue to attach all subsequent CLOSE hoses (G2, G3, etc.).
7. Similarly, connect the return hoses starting with white "G1 OPEN" label from the lower port on cylinder body to the same solenoid valve unit.



White "G1 Open" hoses go to the lower ports

5.19.2 Pneumatic Valve Bank Connection

1. Prepare each crimped hose with labeling and arrange the control layout to the solenoid valve bank.
2. Connect the hydraulic hoses with white label "Gxx CLOSE" to the top port of cylinder body.



3. Route the hose on top of the wire channel and secure with high temperature cable ties.
 4. Connect the other end of the hose to the port of the designated valve unit.
 5. Repeat above steps to connect each hose with "Gxx OPEN" from the lower port on cylinder body to same solenoid valve unit as above.
- Current Bosch Rexroth solenoid valve bank:

"2" port = CLOSE

"4" port = OPEN



5.20 Install Hydraulic Flow Control Valve

1. Install fittings to the flow control valve. The hydraulic flow control valve is used to manually adjust the valve pin opening speed of the connected actuator. It has no effect on the closing speed.



2. Install all fittings onto the mounting plate.



3. Install the flow control valve onto mounting plate using M5 screw.



4. Install all flow control valves onto mounting plate.

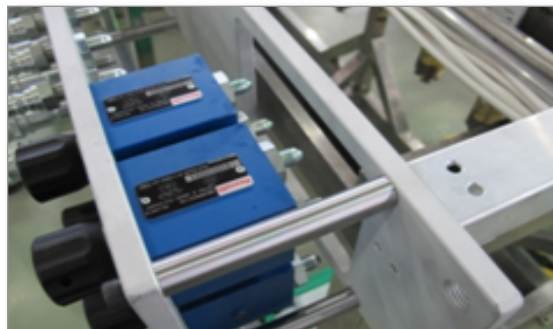

- 5. Connect all the hoses according to the plumbing schematic.

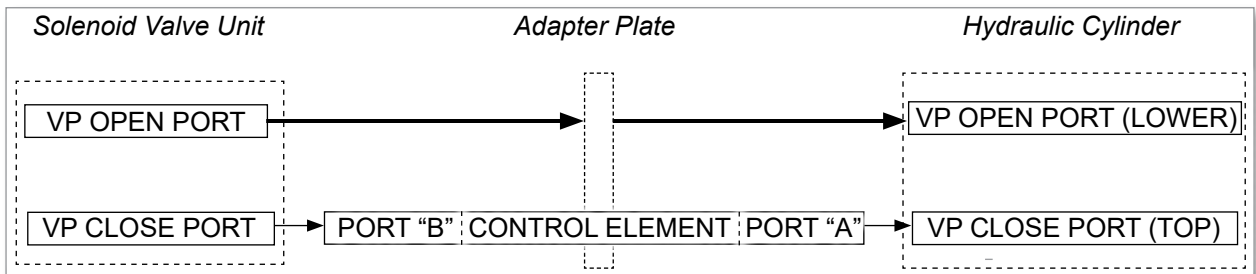

Figure 5-9 Hydraulic flow control valve - connections

5.21 Single Nozzle Hot Runner

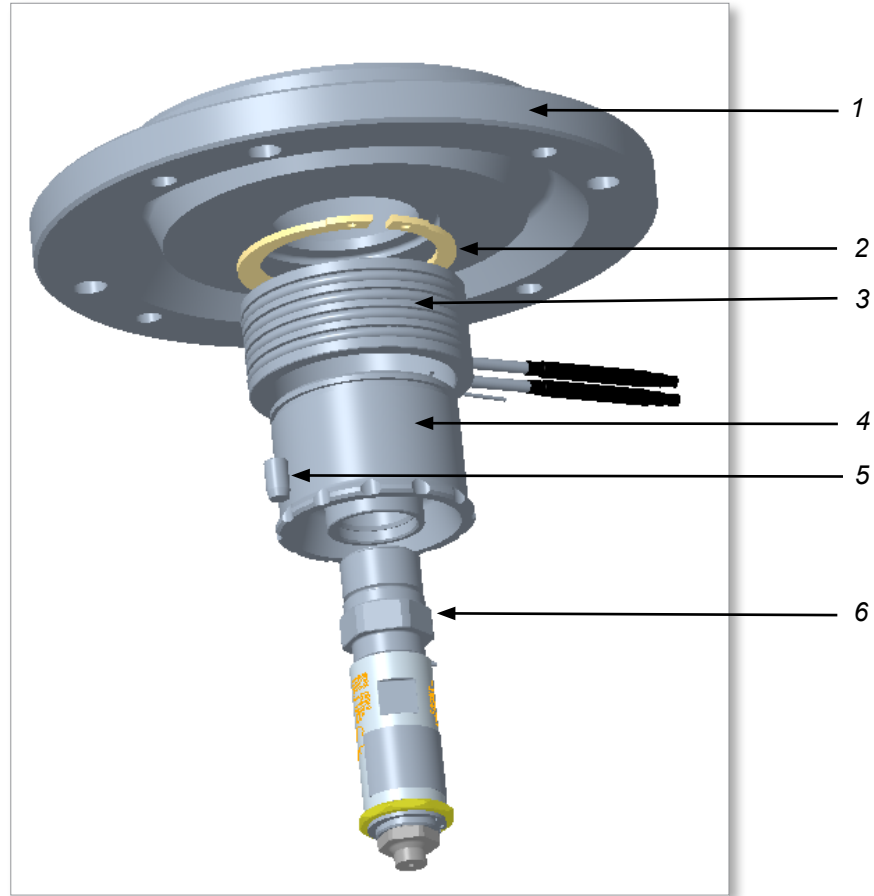

Figure 5-10 Single nozzle assembly

1. Locating ring
2. Snap ring
3. Heater sleeve
4. Back plate
5. Anti-rotation dowel
6. Nozzle subassembly

5.21.1 Assemble the Nozzle

Do the steps in Section section 5.7 Nozzle Assembly for Systems without Protective Sleeves on page 5-12.

5.21.2 Install the Nozzle in the Back Plate

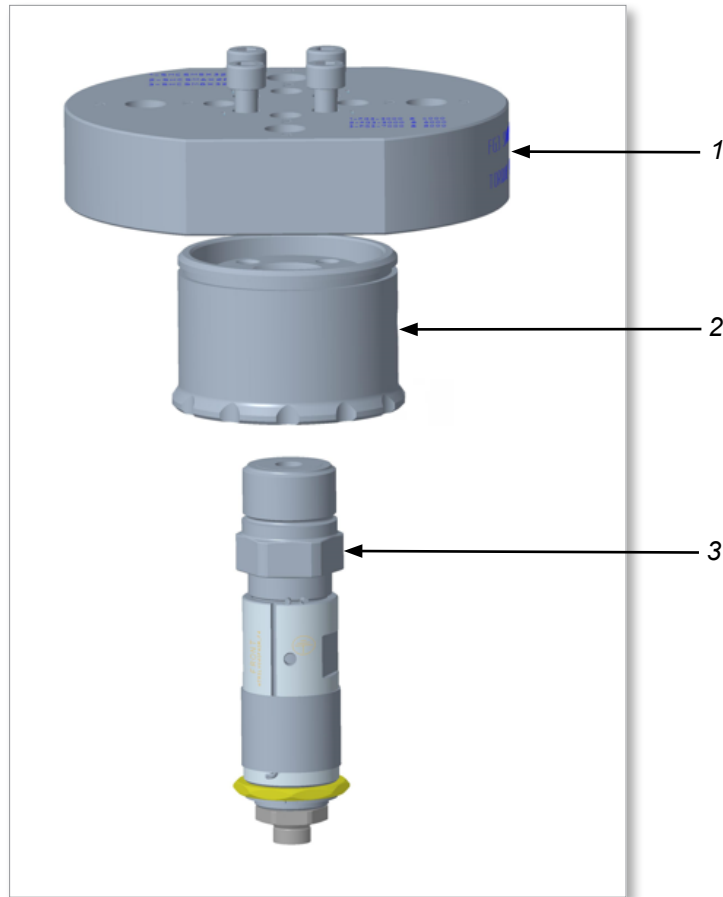

Figure 5-11 Clamping fixture, back plate, and nozzle subassembly

1. Clamping fixture
2. Back plate
3. Nozzle subassembly

1. Insert the 4 clamping screws (F3000&F4000 use SHCSM5X32; F5000&F6000 use SHCSM6X28; F7000&F8000 use SHCSM8X32) in the clamping fixture and use the clamping screws to attach the clamping fixture to the back plate.
2. Insert the clamping fixture and back plate in a vise with the back plate facing upwards and tighten the vise clamps around the clamping fixture.
3. Use your hand to screw the nozzle subassembly into the back plate.
4. Use a torque wrench to tighten the nozzle subassembly. Refer to your GA drawing for torque values.

5.21.3 Assemble the Heater Sleeve

1. Install the thermocouple in the heater sleeve.
2. Install the washer and screw to hold the thermocouple in place.

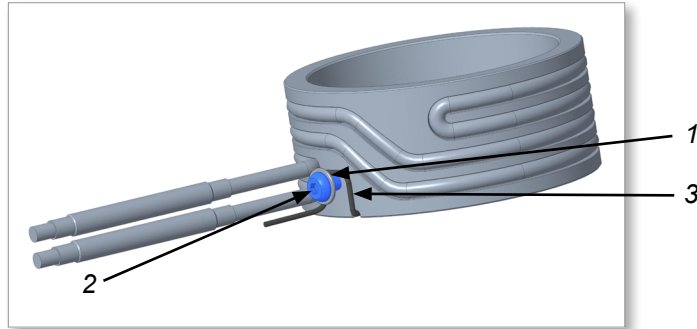
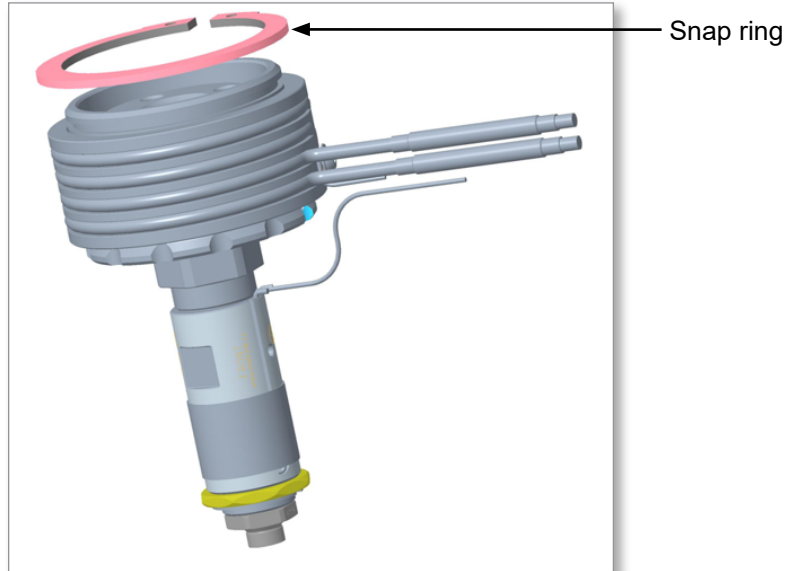

Figure 5-12 Heater sleeve

1. Washer
2. Screw
3. Thermocouple

5.21.4 Assemble the heater sleeve and nozzle

1. Install the heater sleeve on the back plate.
2. Install the snap ring and make sure that the heater sleeve is secure.



3. Rotate the heater sleeve until the exit of the heater sleeve wire and the exit of the nozzle assembly wire are in the same direction.

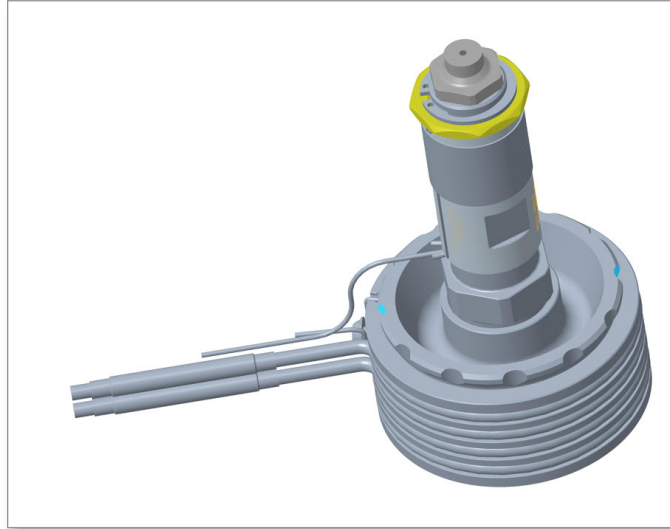

4. When possible, align the exit of the system wire to be 180° opposite to the anti-rotation dowel slot in the back plate.

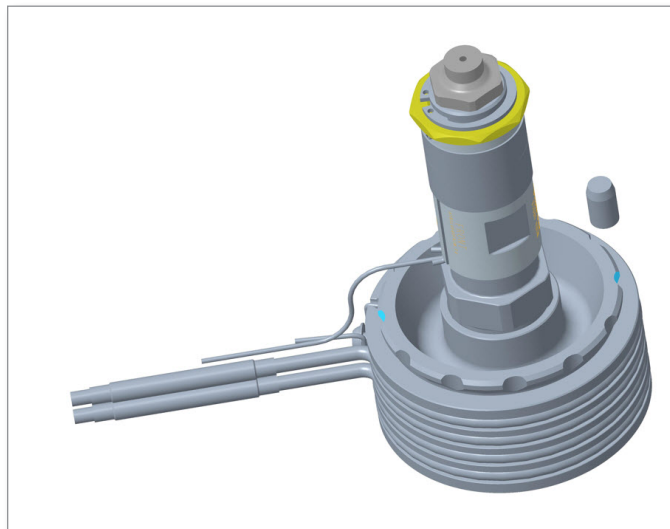

5.21.5 Install the Nozzle in the Plate

1. Install the anti-rotation dowel in the plate.

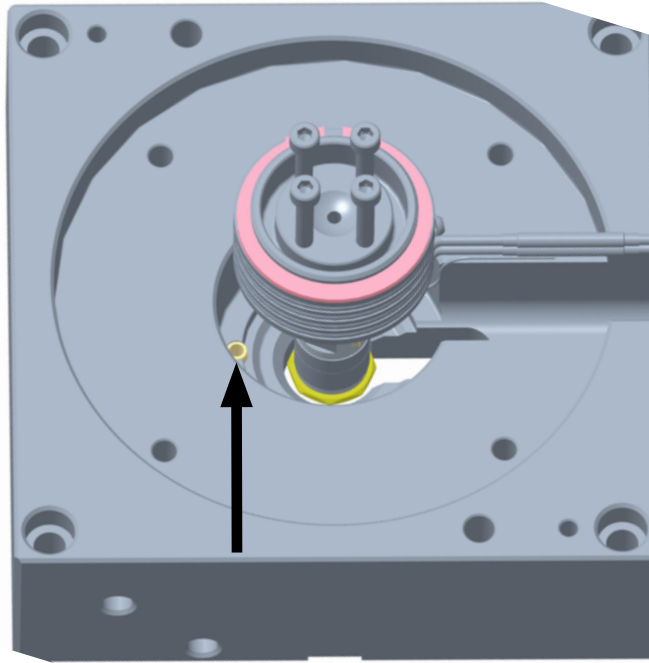

2. Use the 4 screws to install the nozzle assembly in the plate, making sure that a slot in the back plate is aligned with the anti-rotation dowel.
3. Remove the 4 screws.
4. Insert the locating ring into the plate.
5. Make sure that there is an air gap between the locating ring and the back plate. If necessary, grind the bottom surface of the locating ring to create the air gap.

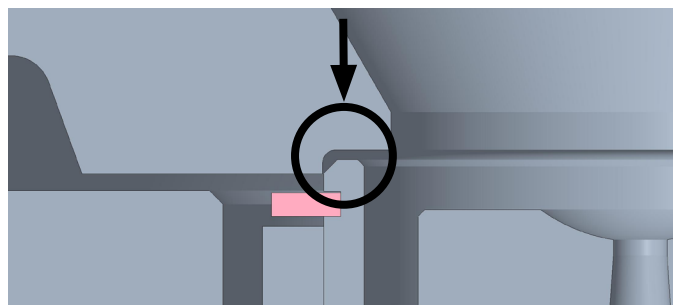
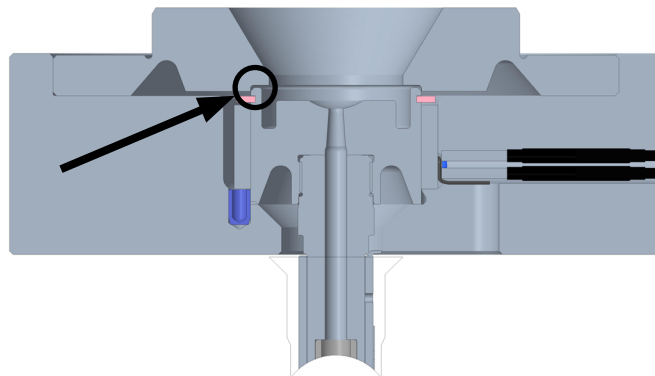

6. Use 4 screws to install the locating ring in the back plate.

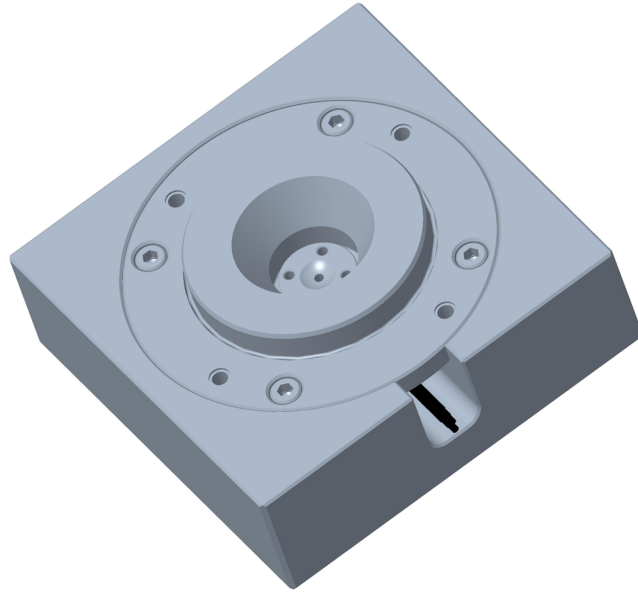

Section 6 - SeVG Plus Actuator

Refer to the SeVG+ user manual for information about SeVG+ actuators.

Section 7 - Electrical Testing



WARNING

Ensure that you have fully read “Section 3 - Safety” before beginning electrical testing.

This section contains guidelines for electrical testing of your *Mold-Masters* Hot Runner system. The testing is based on the following European and North American standards:

- EN 60204-1 / DIN EN 60204-1 (IEC 60204-1, modified) Safety of machinery - electrical equipment of machines
- NFPA 79 Electrical Standard for Industrial Machinery

The standards themselves are the final authority for testing requirements (also any additional testing requirements from any national standards where the Hot Runner is in use).

7.1 Safety



WARNING

The user is responsible to ensure protection against shock by indirect contact, by protective earth conductors and automatic disconnection of supply. *Mold-Masters* components and systems are either equipped with a protective earth conductor or there is a connector for this purpose.

Before you carry out electrical work, make sure that the Hot Runner system is securely grounded. Turn the temperature control off and disconnect all electric wires coming from the mold. Failure to follow any of these steps may lead to serious injury or death.

Ensure that all wiring and connection work is performed by a qualified electrician according to DIN EN 60204-1 / NFPA79.

If performing work on a disassembled nozzle, it should only be connected to an electrical supply when the nozzle has been grounded or a safety isolating transformer is used.

Contact with a disassembled, heated, nozzle would cause serious burns. Use a sign in a visible location indicating “Danger: Do Not Touch”. Wear protective heat-resistant gloves and a full face shield over safety glasses.

7.2 Electrical Wiring Check

1. Check that each wire and thermocouple has a zone number.
2. Check that wires are organized and taped together by zone and plug.
3. Check all wires are secured in wire channels.
4. Connect all power leads and thermocouple wires to mold plugs.
5. The electricity mains should only be connected to the injection mold when all electrical connections are grounded and the mold is closed.

7.3 Electrical Safety Testing

1. Electrical safety tests shall be performed according to DIN EN 60204-1, paragraph 18 and NFPA79. Testing guidelines are given below, however the standards identified earlier in the introduction are the final authority.

7.3.1 Verify Equipment to its Technical Documentation

2. First, verify that the electrical equipment complies with its technical documentation.

7.3.2 Insulation Resistance Test

3. Measure the insulation resistance between each pin of the *Mold-Masters* power connector, in particular the heating circuit and ground.
4. The insulation resistance is measured at a DC voltage of 500V. The insulation resistance must not be less than 1 M Ω .
5. If this value is not reached when heating, the cause is often moisture inside the heating element, which should be removed using a control unit equipped with this function.
6. Where a mold has not been in use for several weeks or months, it should be re-tested.

7.3.3 Verification of Conditions for Protection by Automatic Disconnection of Supply



WARNING

The user is responsible to take protective measures against shock by indirect contact, while performing the tests.

The conditions for automatic shutdown of the supply are set at *Mold-Masters* and usually set such that the protective conductor resistance between the grounding conductor connection and all of the protective earth conductor connected parts, is Maximum 0.3 Ω .

In TN systems the following two checks are made:

7.3.4 Verification of Continuity of Protective Bonding Circuit

Verifies the continuity of the protective bonding circuit. The purpose of this test is to check whether all relevant touchable conductive parts are properly grounded. See the relevant requirements of the standard DIN EN 60204-1 / NFPA79.

The protective conductor resistance is measured with a special instrument with a current between at least 0.2 A and approximately 10 A derived from an electrically separated supply source (for example SELV, see 413.1 of IEC 60364-4-41) having a maximum no-load voltage of 24 V AC or DC. The resistance must be within the expected range.

7.3.5 Verification of Fault Loop Impedance

Fault loop impedance verification and suitability of the associated overcurrent protective device.

The power supply connections and incoming external grounding connections to the Hot Runner system must be verified by inspection (usually through a temperature control device).

The conditions for protection by automatic disconnection of supply must be checked by both:

- Checking the impedance of the fault loop by calculation or measurement.
- Confirming that the setting and characteristics of the associated overcurrent protective device are in accordance with the requirements of the standard.

For more information, see the text of the EN 60204-1/ NFPA79 standards.

7.4 Thermocouple Continuity Test

1. Measure the resistance between each pair of thermocouple wires on the mold's thermocouple connector. The resistance should be between 2.5 Ω and 25 Ω .
2. To verify alignment of thermocouple in the heating element, turn on one zone after the other and check that the temperature responds accordingly if the set temperature is adjusted.

7.5 Pinch Point Test

3. If there is a suspected pinch point on the thermocouple, remove the thermocouple from the Hot Runner.
4. Connect a temperature control device to read the temperature.
5. Immerse the sheath of the thermocouple in boiling water to the point where the thermocouple reads the temperature.
6. A good thermocouple will show a temperature rise as soon as the tip of the thermocouple is immersed in water. If there is a pinch point in the thermocouple there will be no change in the reading until the pinch point on the thermocouple is immersed in water.

7.6 Heating Element Check

Measure the resistance between each pair of heater power wires at the mold power connector.

Compare your reading with your General Assembly drawing.

Where:

$$R = \frac{V^2}{P}$$

R = resistance V = voltage P = power

7.7 Thermocouple Wiring Guidelines



CAUTION

Exceeding controller zone amperage will cause controller fuses to blow.

Thermocouples are Type “J” ungrounded and color coded to ASA standards (White “+”/Red “-”).

The tip must not be truncated or squeezed and must touch the bottom of the bore in order to measure the correct temperature.

Each heat source should have its own closed loop temperature control in order to achieve accurate control. If there are not enough control zones, heat sources that have the same wattage and affect the same environment, may be grouped together.

7.8 Functional Test with a Temperature Controller

The functions of the electrical equipment must be checked. This test is carried out with an appropriate temperature control device.

- Monitor the initial heating of the system to minimize risk.
- Never start the heating with more than 40% of power.
- Stay a minimum of 5 minutes at 100°C (212°F) before increasing heat.

7.9 Retesting

If a portion of the electrical equipment is changed or modified, that portion must be re-verified and re-tested, as appropriate.

Section 8 - Installation



WARNING

Ensure that you have fully read “Section 3 - Safety” before installing your Fusion Series system.

Make sure the lifting eyebolt, lifting chain and crane are rated to adequately support the system. Failure to do so can cause a serious injury.



CAUTION

Do not assemble or disassemble the cavity plate with the valve pins forward.

Potential pinch point for wires. Ensure that all wires are in the retainer grooves.

The following section is a general guide to installing your Fusion Series Hot Runner into an existing manifold plate system or spacer block system. It is important to refer to the General Assembly drawings for full instructions.

8.1 Unpacking

1. Carefully open the shipping crate and inspect the contents. Secure loose items and check for any damage. Remove any documentation or spares packages and set aside.
2. After removing all restraints, attach the sling to the hoist and carefully remove the manifold assembly from the shipping crate.

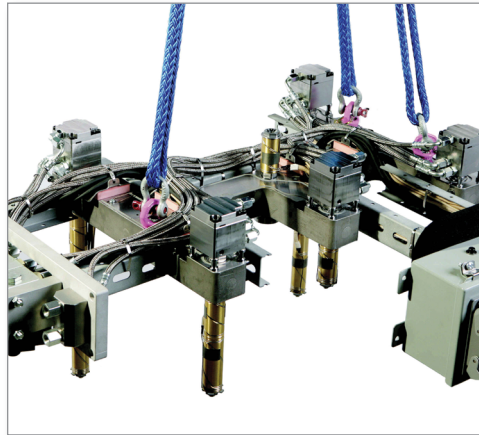

3. Verify all dimensions and tolerances and prepare the manifold for insertion into the mold cavity.
4. Prepare the mold cavity for the Fusion Series manifold insertion.
5. Clean all surfaces and dowel holes, ensuring that no debris, burrs, shavings, dust, dirt, or other foreign material which could interfere with fit. Ream mold (cold half) holes if necessary.

8.2 Pre-Installation

1. Verify all dimensions, tolerances, angles, taps, chamfers, etc. of the mold, against the engineering and General Assembly drawings.
2. Record values for future reference.
3. Verify centers, depth tolerances, radii against General Assembly drawings.



NOTE

If the molding elevation is out of tolerance within $+ / - 1.0\text{mm}$ of the General Assembly drawings, a support bushing with extra stock can be ordered from *Mold-Masters*. This bushing can then be machined from its bottom face to compensate for the system height difference caused by mold plate thickness.

8.3 Install Manifold Locator Dowel

1. Using a depth micrometer, verify the dimensions of the manifold locator pocket to those specified on print.



2. Apply anti-seize compound to screw.
3. Install the manifold locator dowel.

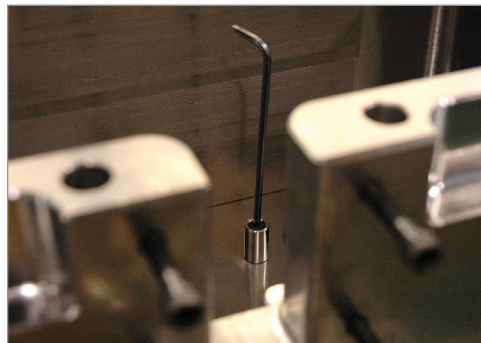

8.4 System Installation



CAUTION

Make sure that the machine nozzle orifice matches or is maximum 1.0 mm (0.040 in.) smaller than the melt entrance of the Hot Runner system. After the Hot Runner system is installed in the molding machine, make sure to bleed all the air from the hydraulic lines or a high gate vestige could occur.



CAUTION

For Fusion Series® Lite systems, the wiring and plumbing layout and connections should be designed and planned by a tool shop before system installation.



CAUTION

Fusion-Series G3 nozzles are drop-in systems. They must be installed in a cold condition.

1. Carefully install the system in the mold, ensuring that the manifold remains level to avoid damage to the nozzle wiring. Lower the system, and make sure that it is correctly seated.

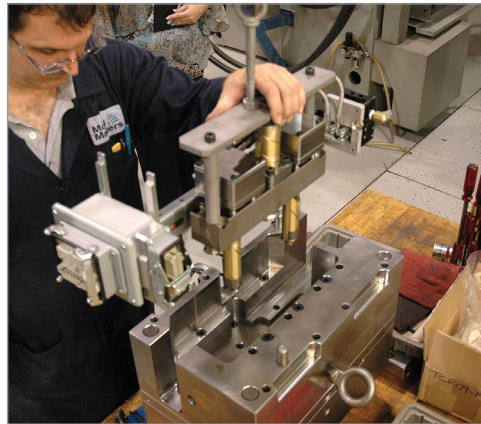

2. Remove any installation tools (e.g., the lift bar).

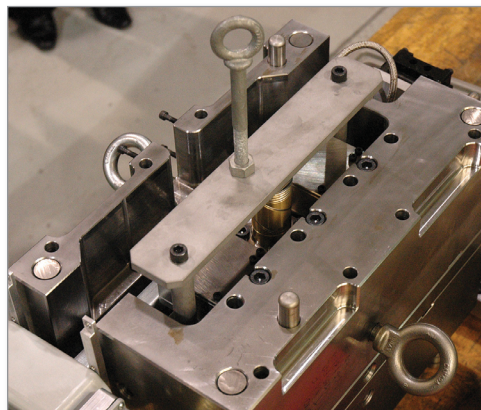

3. Apply anti-seize compound to the system screws and install the screws.



4. Torque the system screws in a cross pattern, gradually increasing the torque to specified value.
5. Install the screw to secure the electrical and solenoid interface to the exterior of mold base.
6. Install the clamp plate.
7. Connect all water lines and test. Water temperature is not to exceed 30°C (85°F).
8. Water to Fusion Series valve actuators must be turned on before heating is activated.
9. Connect all electrical, hydraulic / pneumatic lines, as applicable.

8.5 System Test



WARNING

Assume the system is pressurized and hot at all times. Failure to do so can result in a serious injury or death.

After system installation with all connections in place, it is important to validate that the Hot Runner system is functioning properly before you start it up.

1. Turn on the cooling water and oil or air, check all connections and hoses to ensure no leakage.
2. Turn on the Hot Runner system heaters (manifold and nozzles).
3. Monitor the temperature control unit to ensure all zones are stable in process temperature.
4. Test to see that the actuator / valve pin move properly. Ensure that:
 - a) the valve pin moves fast and smoothly
 - b) the valve pin moves in the correct direction. If not, check the connection
5. If solenoid sequential control is used, activate each control station to ensure:
 - that each solenoid valve drives the designated actuator and no others. If any problem is seen then check wiring and hose connections.
 - that the valve pins move in the right direction:
solenoid activate - pin open
solenoid deactivate - pin close



NOTE

For a pneumatic solenoid valve bank that is supplied by *Mold-Masters*, the test can be done with the manual override function that is built into the valve, without connecting it to sequential controller.



System test - continued

6. If applicable:

Hydraulic Flow Control:

Turn the dial to the maximum value and activate the solenoid valve. The valve pin open speed should gradually get slower as the setting value decreases from 10 to 1.

Normally the unit is set for slow down only when opening while closing is constant speed. If you observe the unit is slowing down on closing then investigate. It is possible that the unit is malfunctioning or that settings have been changed.



Valve Pin Position Monitoring

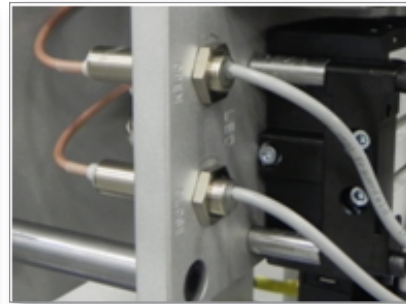

NOTE

The flow control valve is lockable and the key can be used to unlock all valves.

- Check to ensure the signal indication on controller screen or LED board matches the valve pin position.
- Manually activate the actuator to confirm the signal is switching and stable.
- Check to ensure that:
 - the wiring and connection are correct, as per the General Assembly drawings
 - the proximity sensor is mounted properly and that the sensing probe is also mounted within its sensing distance and in the correct position
 - if mechanical limit switch is used, then the switch is being pressed down properly

Section 9 - Startup and Shutdown



WARNING

Ensure that you have fully read “Section 3 - Safety” before starting up or shutting down your Fusion Series system.

9.1 Pre-Startup



WARNING

Take appropriate safety precautions by assuming the system is pressurized and hot at all times.



CAUTION

Water must be turned on for Hot Runner actuation before turning on temperature controls. Actuator water temperature cannot exceed 29.4°C (85 °F).

When running thermally sensitive materials, use a thermally stable material as recommended by the material supplier for the initial startup.

After the Fusion Series system is installed in the molding machine, make sure to bleed all the air out of the hydraulic lines, if applicable. Failure to do so could result in high gate vestige.

Check that the system is heated to processing temperature before actuating the valve pins. Failure to do so could cause damage to the valve pins.

The maximum operating temperature for Hot Runner systems is 400°C (750°F).

1. Install the mold into the molding machine.



NOTE

Ensure that the machine nozzle opening is the same size, or is **not more** than 1.0 mm (0.040 in.) smaller, than the back plate bore.

2. Connect all water lines and test to ensure there are no leaks and that the required flow is achieved in all water circuits.
3. Connect all hydraulic / pneumatic lines, if applicable.
4. Connect all electrical components and monitor to ensure that all zones are receiving heat and all thermocouples are reacting appropriately.
5. If applicable, test the valve pin actuation, but only if the Fusion Series system is at processing temperature. See previous **CAUTION**.

9.2 Startup



WARNING

When the mold is open never inject material through Fusion Series system under high pressure. Failure to do so can result in serious injury or death.



CAUTION

Failure to follow this procedure may result in leakage / damage occurring in the Fusion Series system.



IMPORTANT

When running thermally sensitive materials, use a thermally stable material as recommended by the material supplier for the initial startup.

6. Turn on the machine barrel and mold cooling system.
7. Prior to start up, ensure the:
 - a) Machine barrel is up to processing temperature.
 - b) Mold cooling is on and at cooling temperature.
8. Heat up all manifolds and / or bridges and inlets (excluding the nozzles) to processing temperature.
9. Begin nozzle heating when the manifolds and / or bridges have come within 50°C of processing temperature.



IMPORTANT

Wait until ALL heating zones have reached processing temperature for 5 minutes before continuing.

For Fusion Series systems using heater plates, allow 10 minutes of soak time after the system reaches processing temperature.

10. Startup the system.
 - a) For empty systems or where there is no material in the gate detail, extrude material through the hot runner system using 14 bar (200 PSI) of back pressure.
 - b) For systems filled with material, purge intended shot size twice from the barrel prior to bringing the machine barrel forward to the Hot Runner interface.
11. Set injection time and pressure according to part size, gate size and material.

9.2.1 Shutdown

**CAUTION**

Failure to follow this procedure may result in leakage / damage occurring in the Fusion Series system.

**IMPORTANT**

Thermally sensitive materials should be purged from the Fusion Series system prior to shutdown using a thermally stable material with a similar processing temperature.

12. Turn off all heat to the system.
13. Leave the mold cooling system turned on until the Fusion Series system temperature is within 55°C (130°F) of the mold temperature.

Section 10 - Color Change



WARNING

Ensure that you have fully read “Section 3 - Safety” before purging your Fusion Series system, paying special attention to the recommendations for personal protective equipment.

10.1 Introduction

To change from one color to another, it is necessary to remove all traces of the first color from the injection molding system. Refer to the following procedures to assist in performing the color change.

Before commencing color change, review the following safety warnings.

10.2 Color Change for a Hot Tip / Sprue System

1. Ensure the system is running properly with the first color.
2. Back off the machine barrel, purge, and introduce the new color.
3. Increase the Hot Runner system temperature on all zones 15-25°C (59-77°F) above processing temperature.
4. Increase injection speed.
5. Run 10 - 15 shots.
6. Back off the injection unit and switch off all heat on the Hot Runner. Leave mold cooling on.
7. Allow the Hot Runner system to cool down. This pulls the old material away from the runner walls.
8. Turn ON the Hot Runner system and heat to processing temperature.
9. Bring machine barrel back in.
10. Increase injection speed and (mold temperature) until the color change is acceptable.
11. Continue processing while re-setting Hot Runner system temperatures and injection speed back to normal.



10.3 Color Change for a Valve Gate System

CAUTION

Do not activate the valve gate while purging or feeding the barrel, unless the Hot Runner system has reached normal processing temperature.

1. When the system is up and running with one color, back-off the injection unit, purge and introduce the new color.
2. Start molding the new color until the majority of old color has been removed from the Hot Runner system.
3. Back-off the injection unit and switch off all heats on the Hot Runner system.
4. Allow the Hot Runner system to cool down. Leave mold water cooling / actuator cooling on. This pulls old material away from the runner walls and allows new and old color to mix.
5. Heat up the system and start molding.

10.4 Locating a Source of Contamination

6. Purge the original color from the machine, following the instructions in:
 - section 10.2 Color Change for a Hot Tip / Sprue System on page 10-1
 - section 10.3 Color Change for a Valve Gate System on page 10-2
7. Load the hopper with a second color (different from the intended color).
8. Continue to purge until no trace of the first color appears.
9. Shut off the hopper and continue to remove the second color, following the instructions above.
10. Load the hopper with the third, and final intended color.
11. Purge the third color through the injection unit to clean the injection unit of the second color.
12. Continue to purge until no trace of the first color appears.
13. If the second color appears in the molded product then the problem is in the injection unit.

Section 11 - Maintenance



WARNING

Ensure that you have fully read “Section 3 - Safety” before doing maintenance procedures on your Fusion Series system.

11.1 Recommended Torque Settings

The torque value for gate seals, the nozzle flange and the inlet tip are at processing temperature. These should be torqued at ambient (room) temperature and then re-torqued at processing temperature to the torque value specified. This is to prevent material leakage from the gate seal.

Torque sequence and step torquing: *Mold-Masters* recommends that manifold mounting screws be torqued in a standard bolt pattern and that the specified torque is achieved in 3 steps (1/3, 2/3 and full torque).

Quality and length of screws must be as specified on *Mold-Masters* General Assembly drawings.

Table 11-1 Recommended Torque Settings					
Description	Reference Part #	Product Line	Wrench Size mm (inch.)	Torque Value Nm	Torque Value (ft-lbs)
Gate Seals*	All	F3000	12 (0.47)	27	20
		F4000	14 (0.55)	45	33
		F5000	18 (0.71)	57	42
		F6000	27 (1.06)	88	65
		F7000	32 (1.26)	95	70
		F8000	41 (1.61)	270	200
Nozzle Body*	Application Dependant	F3000	21 (0.83)	80	59
		F4000	24 (0.94)	85	63
		F5000	27 (1.06)	88	65
		F6000	36 (1.42)	135	100
		F7000	41 (1.61)	183	135
		F8000	60 (2.36)	450	332
Piston Top	All	All	8 mm (0.25 in) hex key	10	7.5
Inlet Tip*	IE08TP****	F3000	36 (1.41)	88	65
	IE09TP****	F4000			
	IE13TP****	F5000			
	IE14TP****	F6000			
	IE32TP****				
	IE29TP****	F7000	50 (1.97)	360	265
	IE30TP****	F8000			
	IE33TP****				

Table 11-1 Recommended Torque Settings					
Description	Reference Part #	Product Line	Wrench Size mm (inch.)	Torque Value Nm	Torque Value (ft-lbs)
Actuator Mounting Screw	SHCS M4	All	3 (0.12) (Hex Key)	4.6	3.4
	SHCS M5	All	4 (0.16) (Hex Key)	9.5	7
	SHCS M6	All	5 (0.20) (Hex Key)	16	11.8
Manifold Mounting Screw	SHCS M10	All	8 (0.31) (Hex Key)	40	30
	SHCS M16	All	14 (0.55) (Hex Key)	145	107
Heated Flange Mounting Screw	SHCS M6	All	5 (Hex Key)	14	10.3

* For these components, torque value is at processing temperature.

11.2 Tubular Heater



WARNING

Heater elements should be installed by qualified personnel.

The heater element and heated block must be connected and grounded during maintenance according to local electrical standards, e.g. DIN EN 60204-1 or NFPA79.



CAUTION

Do not use a metal hammer, it will damage the heater and the manifold surface.



IMPORTANT

Fusion Series manifolds are supplied with tubular heaters. These tubular heaters are interchangeable with equivalent flexible heaters.

For Field Replacement of Ø 8.0 mm and Ø 8.5 mm Flexible Heaters Only

Mold-Masters only recommends field replacement of Ø 8.0 mm (0.31 in.) and Ø 8.5 mm (0.33 in.) flexible heater elements. We do not recommend field replacement of heater elements that are brazed or pasted into the manifold. For these types of heater elements, please contact your service representative.

11.2.1 Storing

- Heater elements should be stored at room temperature and in a dry atmosphere.
- The heater element insulation material attracts and hold moisture. If there is a chance it has been exposed to high humidity during storage, then the insulation resistance should be confirmed prior to installation ($R_{min} = 5 \text{ M}\Omega$ at 500 V DC). If necessary, heating elements should be dried at a temperature of 120°C (250°F) for a few hours.

11.2.2 Removing a Heater Element

1. Disassemble wires and ceramic terminal connector from the failed heater element. Label the wires to identify them for re-assembly.
2. Use pliers to lift the heater element's exit portion and insert a brass stick below the heater element. Pull the heater element out of the groove while prying it up with the brass stick.
3. Clean the manifold heater element groove with a brass brush and make sure there is no contamination or sharp edges.

Installing a New Heater Element - continued

11.2.3 Installing a New Heater Element

1. Prior to installation, check the General Assembly drawings for the correct heater element size and confirm the replacement conforms.
2. Check that the connection voltage does not exceed the heater element's operating (nominal) voltage.
3. Remove the spare nut and washers supplied on the threaded heater element pin. Tighten the remaining nut, next to the ceramic ring, to 1 Nm (8.85 lbf.in.) to provide proper sealing and protection.



4. Align the center of the heater element to the center marking on the manifold groove. Always start the heater element installation from the middle point of the path. We recommend installing the heater element gradually from both sides in parallel. This will help to get an equal exit length.

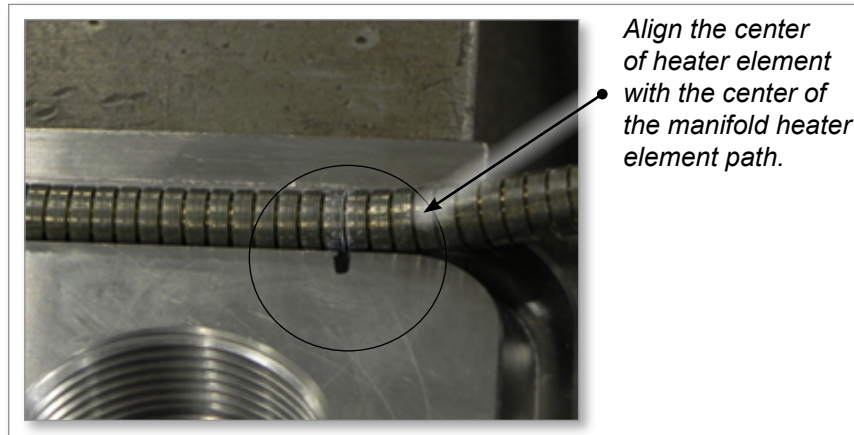

Installing a New Heater Element - continued

5. Use a plastic (nylon) mallet to tap the element straight down into the groove. This will help to prevent the heater element from stretching.



6. For the curved areas of the groove, pre-bend the heater element manually before hammering it into the groove. This will prevent the shielding from being damaged by the groove edge.
7. Make sure the heater element is completely seated inside the groove. The heater element should be 0.5 mm (0.02 in.) lower than the top surface.

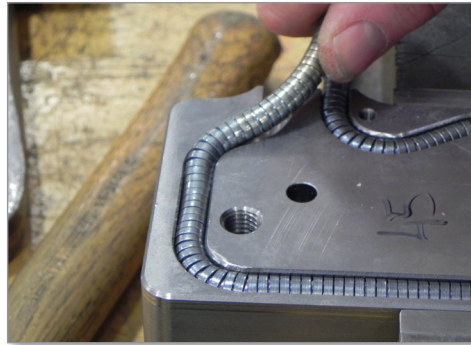

8. Do not bend the unbendable zones of the heater element. This is the last 35 mm (1.4 in) area on each end. See below.

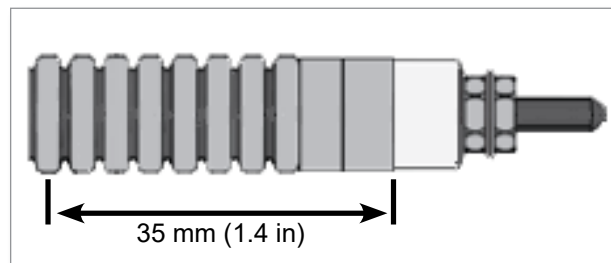

9. Crimp the wire with the proper size crimper pin. Connect it to the heater threaded pin with the ceramic terminal connector.



10. After all connections are finished test the electrical connections to proper electrical standards.



11.2.4 Starting up a New Heater

To protect the heat element from failure at startup, we highly recommend using a soft start feature on the controller.

11.3 Solenoid Valve Bank

A hydraulic or pneumatic solenoid valve bank is used to control the opening and closing of each gate separately. It is mostly used for large automotive parts where individual control of each valve gate opening timing and sequencing is important, for example, to avoid or control welding line location and proper part filling. Sequential valve control can be provided by injection machine or other surrounding controller. The following sections provide more information about hydraulic and pneumatic solenoid control valves which may assist system startup and maintenance.

11.3.1 Hydraulic Solenoid Valve Bank

The standard hydraulic valve bank has been completely assembled and tested before shipping. The standard package includes a pressure reducing valve that protects the downstream actuators.

There are two options for standard solenoid valvebank due to the operating voltage difference: 24VDC and 110VAC. Check to make sure which version is in the system before starting any maintenance on the valve bank.

Due to its stackable design, the valve bank assembly can be easily changed by adding or removing valve elements to meet specific requirement in the field. The parts need to be ordered and replaced are only the bolt kits and new valve elements if adding station required. Contact your *Mold-Masters* representative for detail.

11.3.2 Components of a Hydraulic Solenoid Valve Bank

- a) 4/2 Directional Valve Element
 - Size 6
 - Maximum operating pressure 310 bar [4500 psi]
 - Maximum flow 30 l/min [7.9 gpm]
 - Port connections G 3/8 - SAE6

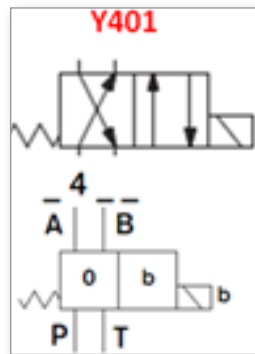

- b) Pressure Reducing and Relieving Valve (PRV)

Reduce the oil pressure to actuator in order to prevent it from damage due to unexpected high pressure. The maximum working pressure of the PRV is 350 bar (5076 PSI) and its adjusted pressure range is 28-80 bar (406-1160 PSI). In other words, the pump pressure to the

Components of a Hydraulic Solenoid Valve Bank - continued

valve bank is not the main concern since the maximum pressure to the actuator is 80 bar, as long as the reduce valve is working properly. The default setting of the PRV is 45-50 Bar (653-725 PSI), which is safe for actuators.

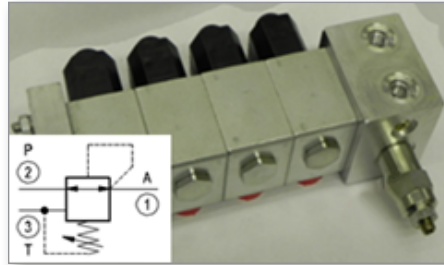

Figure 11-1 Pressure reducing and relieving valve

c) Manometer Mounting Port

On the end cap of the hydraulic valve bank, there is a nominated “GA” port that is used to install a pressure gauge. This gauge monitors the hydraulic oil pressure which is delivered from molding machine, or pumping power station, to the valve bank. The pressure will be reduced to 45-50 bar (653-725 PSI) by the PRV before sending to actuators. If you need to monitor and manipulate the actual hydraulic pressure that is driving the actuator, there are two ports that can be used to install the pressure gauge.

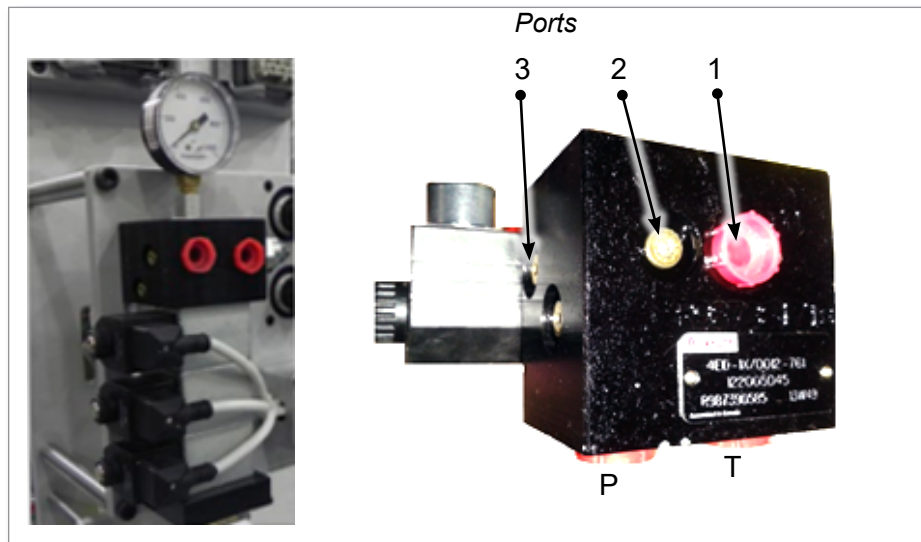

Figure 11-2 Manometer mounting port

Gauge Port	Thread Size	Pressure Monitoring
1	SAE#4	Pump to solenoid valve bank
2,3	SAE#3	Solenoid valve bank to actuator

d) Manual Override Pin

Components of a Hydraulic Solenoid Valve Bank - continued

This allows you to push the spool to reset the valve in emergency conditions, for example, when there is a power shortage the solenoid cannot be energized.

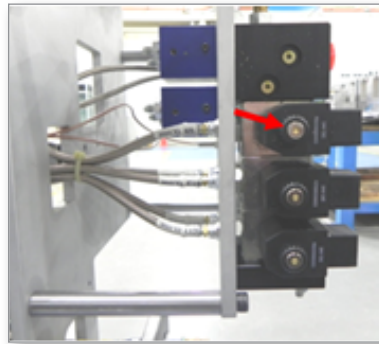

e) Solenoid Connector

Refer to below specification for spare parts if not ordered from *Mold-Masters*:

- ISO, 6 ft wire length, 2+ ground, U.S.A. wire code / PVC jacket
- Rated voltage max.: 250V AC 50 / 60 Hz, 300V DC
- Rated current max.: 10 Amps (ISO standard housing color)

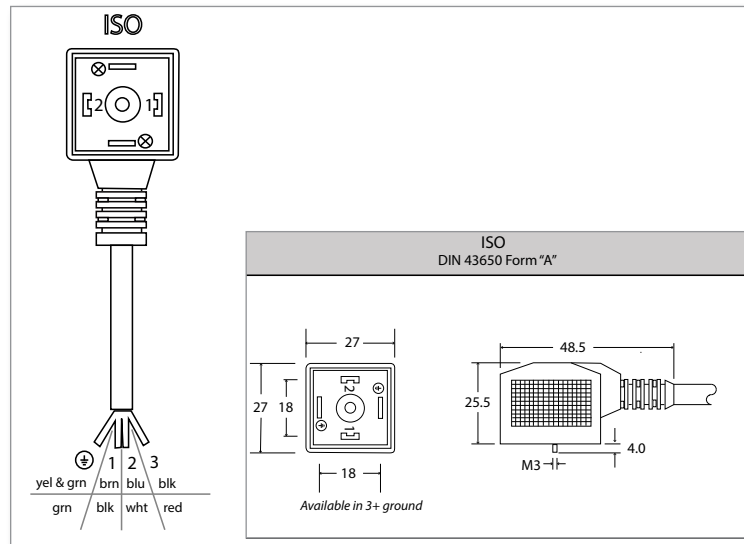
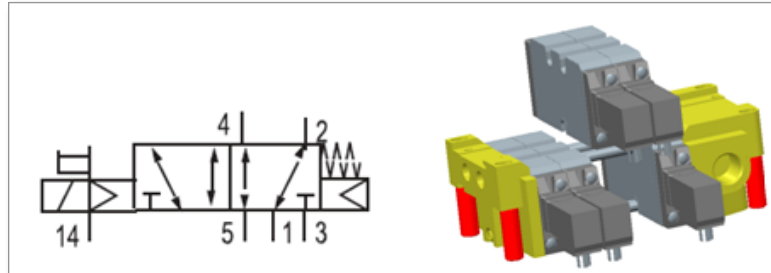

Figure 11-3 Solenoid connector

Components of a Pneumatic Solenoid Valve Bank - continued

11.3.3 Pneumatic Solenoid Valve Bank

The stackable valve bank could be supplied from 2 to 12 units. If reducing or adding new solenoid stations are needed, contact *Mold-Masters* representative for details.



11.3.4 Components of a Pneumatic Solenoid Valve Bank

- a) Valve Element TC08 5/2 Single Solenoid - Specification
 - Thread connection 1/8" NPTF
 - Single solenoid, spring return
 - Electrical connector Form C
- b) Valve Bank Assembly



NOTE

Do not plug the ports #82 & #84 when you use the internal pilot mode.

1. Install the external muffler to the ports #3 and #5.

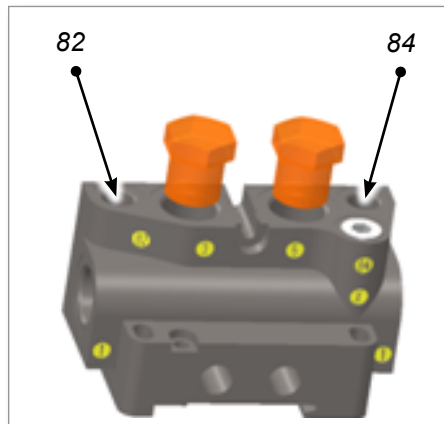

Components of a Pneumatic Solenoid Valve Bank - continued

2. Insert the gasket and O-ring into the right end plate.

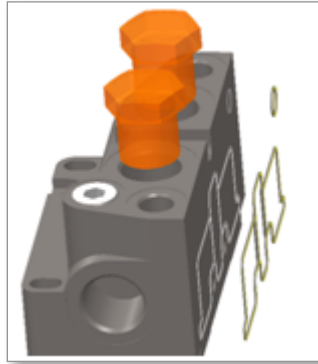

3. Insert the screws with your hand and assemble the end plates into the lower two tie rods.

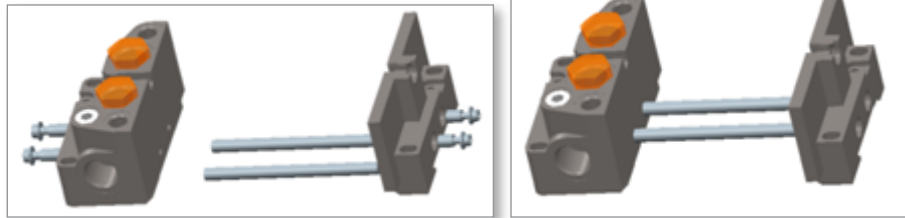

4. Use the light pressure latch valves onto the lower tie rods and insert the upper tie rod into the system.

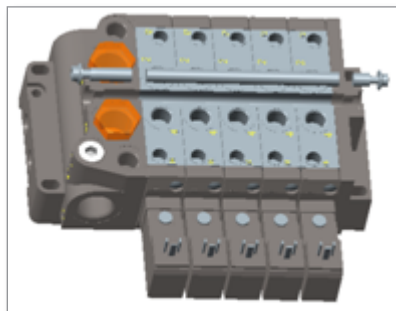
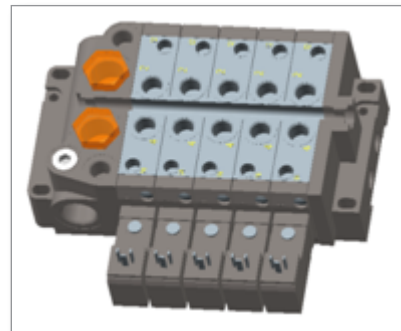
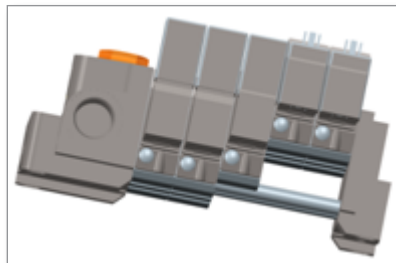

5. Evenly tighten the tie rod mounting screws with a torque of 2+0.5 Nm (17.7+4.43 lbf.in.).
6. Install solenoid connectors and hose fittings.

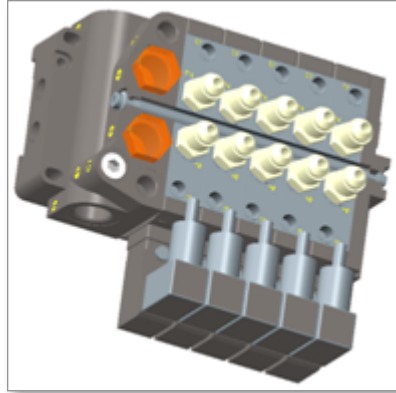

a) Manual Override Switch

You can manually activate and deactivate the valve in order to drive the valve pin, without connecting to the solenoid controller.



NOTE

Make sure manifold and nozzles are at process temperature before adjusting this switch. Confirm the switch is in the right orientation “O” before starting production run.

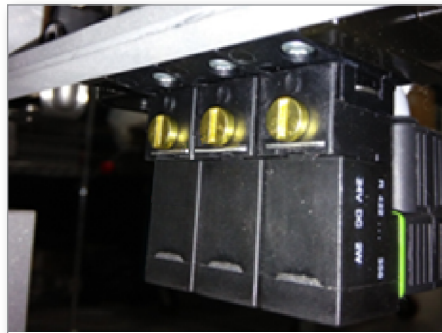

Figure 11-4 Manual override switch

b) Solenoid Form C Connector

Specification:

- ISO 15217:2000, 3 m (9.84 ft.) wire length, housing color: black
- Rated voltage max.: 24V AC / DC
- Rated current max.: 6 Amps
- LED status display: yellow



11.4 Hydraulic Hoses, Fittings, and Seals

11.4.1 Specifications

- Hydraulic hoses are rated for temperatures up to 232°C.
- Hydraulic oils typically start to degrade at 60°C.

11.4.2 Hose Failure

Hydraulic power is accomplished by using high pressure fluids to transfer energy and do work. Hoses, fittings and hose assemblies all contribute to this by transmitting fluids at high pressures. Occasionally Hose assemblies will fail if they are not replaced at proper time intervals. These failures are usually the result of some form of misapplication, abuse, wear, or failure to perform proper maintenance. When hoses fail, generally the high-pressure fluids inside escape in a stream which may or may not be visible to the user. Simply shutting down the hydraulic pump may not eliminate the pressure in the hose assembly. Check valves and others are employed in a system and can cause pressure to remain in a hose assembly even when pumps or equipment are not operating.



WARNING

Fluids under pressure can be dangerous and lethal. Use extreme caution when working with fluids under pressure and handling the hoses transporting the fluids.



WARNING

Do not attempt to locate a hydraulic leak by feeling with your hands or any other part of their body. High pressure fluids can penetrate the skin and cause severe tissue damage and loss of limb. Even minor hydraulic fluid injection injuries must be treated immediately by a physician.



WARNING

Do not attempt to patch or repair a hose assembly that has failed. Never touch or examine a failed hose assembly unless it is obvious that the hose no longer contains fluid under pressure. High pressure fluid is extremely dangerous and can cause a serious and potentially fatal injury.

Tiny holes in a hose, commonly known as pinholes, can eject small, dangerously powerful but hard to see streams of hydraulic fluid. It may take several minutes or even hours for the pressure to be relieved so that the Hose Assembly may be examined safely. Once the pressure has been reduced to zero, the hose assembly may be taken off the equipment and examined. It must always be replaced if a failure has occurred. Consult the nearest hose distributor or company for hose assembly replacement information.

11.4.3 Maintenance Schedule

Visual inspection of hoses and connections should be conducted at installation.

- A functional test should be conducted prior to installation.
- A visual inspection should be completed at each PM or once per year, whichever comes first.
- A functional test should be conducted and recorded every two years.
- Each application is unique and the above information is a guideline only. Your application may require a more frequent maintenance schedule.

11.4.3.1 Replacement Intervals

Hose assemblies and elastomeric seals used on hose fittings and adapters will eventually age, harden, wear, and deteriorate under thermal cycling and compression. Hose assemblies and elastomeric seals should be inspected and replaced at specific replacement intervals based on previous service life, government or industry recommendations, or when failures could result in unacceptable downtime, damage, or injury risk. Hoses and fittings may be subjected to internal mechanical and/or chemical wear from the conveying fluid and may fail without warning. You must determine the product life under such circumstances by testing.

11.4.4 Maintaining and Replacing Hoses, Fittings, and Seals

Even with proper selection and installation, hose life may be significantly reduced without a continuing maintenance program. The severity of the application, risk potential from a possible hose failure, and experience with any hose failures in the application or in similar applications should determine the frequency of the inspection and the replacement for the products so that products are replaced before any failure occurs. A maintenance program must be established and followed by the user and must include at least the following



WARNING

Avoid potential hazardous areas while testing and using the system.

1. Do a visual inspection of the hose and/or fitting. If you find any of the following conditions, immediately shut down and replace the hose assembly.
 - Fitting slippage on hose
 - Damaged, cracked, cut or abraded cover (any reinforcement exposed)
 - Hard, stiff, heat cracked, or charred hose
 - Cracked, damaged, or badly corroded fittings
 - Leaks at fitting or in hose
 - Kinked, crushed, flattened or twisted hose
 - Blistered, soft, degraded, or loose cover

2. Do a visual inspection of all other parts. Tighten, repair, correct, or replace as required.
 - Leaking port conditions
 - Excess dirt buildup
 - Worn clamps, guards, or shields
 - System fluid level, fluid type, and any air entrapment
3. Do a functional test: Operate the system at maximum operating pressure and check for malfunctions and leaks.

11.4.4.1 Maintaining Elastomeric Seals

Elastomeric seals eventually age, harden, wear, and deteriorate under thermal cycling and compression.

1. Inspect the elastomeric seals and replace as necessary.

11.5 Recommended Spare Parts

Mold-Masters recommends that you keep the following spare parts ready for quick replacement in order to prevent any long shutdown time.

- Inlet tip if applicable.
- Heaters:
 - Common heater sleeves of the nozzles and inlet extension in the system
 - Replaceable heaters for the manifold
 - Heater plates if applicable
- For spare actuator seal kits, see the Fusion G3 resource guide.
- Nozzle spring clip: the one in the front of nozzle to hold heated sleeves in place. See system parts list for part numbers.
- Common length valve pins and gate seal component for the systems are also recommended.

11.6 Extracting a Headless Valve Pin

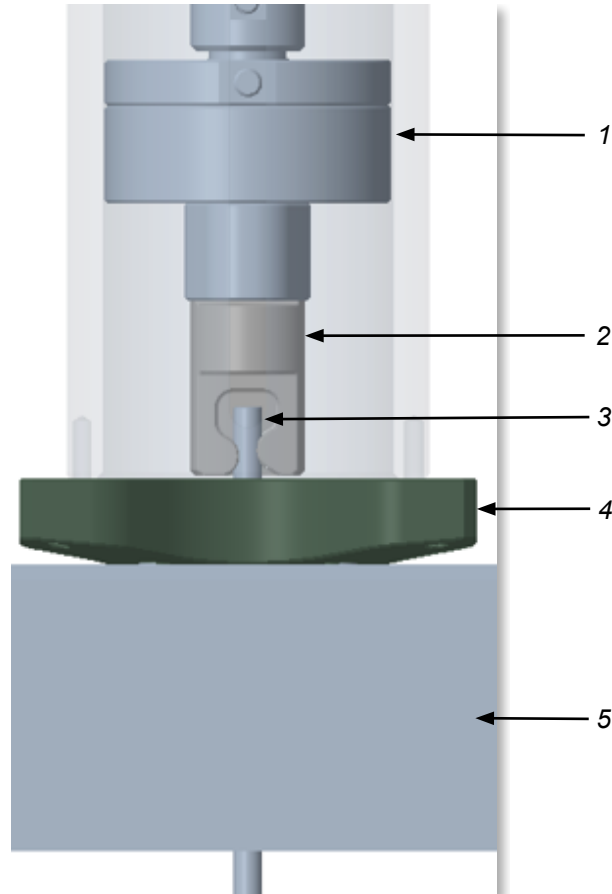
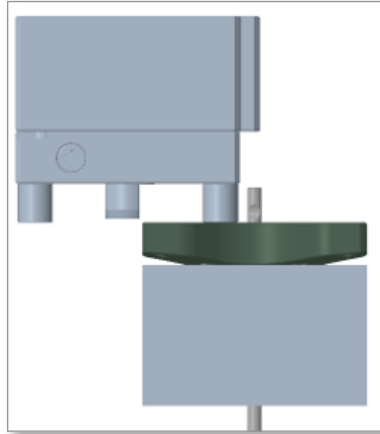

Figure 11-5 Extraction of headless valve pin

1. Extraction puller (EXTOOLAS10)
2. Extraction adapter
3. Valve pin
4. Valve disk flange
5. Manifold

Table 11-2 Extraction Adapters	
Pin Diameter (mm)	Extraction Adapter
3.0	EXTOOL49
5.0, 6.3	EXTOOL50
8.0, 9.5	EXTOOL51

1. Quick release the actuator from the valve pin.



2. Attach the extraction adapter to the valve pin.

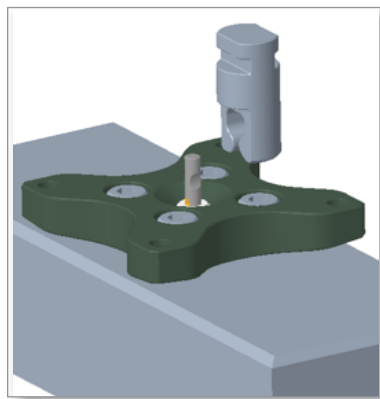

3. Make sure that the valve pin and the adapter are properly aligned.

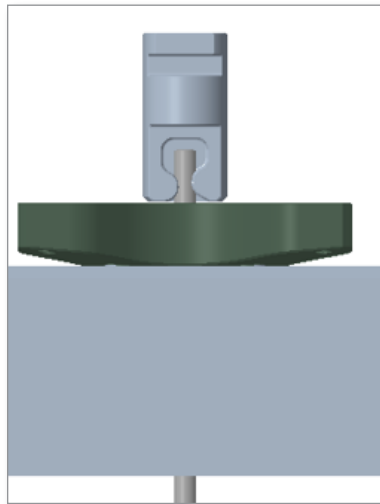

4. Attach the extraction puller (EXTOOLAS10) to the extraction adapter.

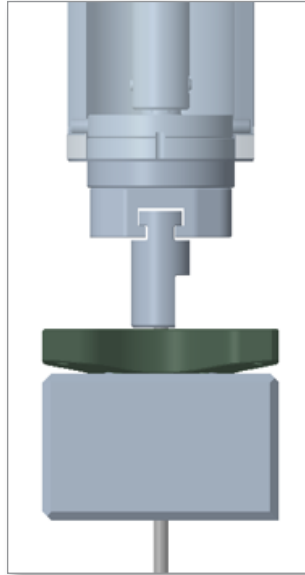

5. Use a 13 mm (1/2") wrench or power tool to unscrew the bolt of the extraction puller and extract the valve pin.

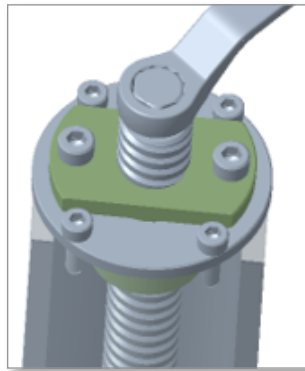

Section 12 - Troubleshooting

12.1 Introduction



WARNING

Ensure that you have fully read “Section 3 - Safety” before troubleshooting any issues with your Fusion Series system.



WARNING - HOT SURFACES

Extreme heat. Avoid contact with heated surfaces. To avoid serious burns wear safety clothing consisting of a protective heat resistant coat and heat-resistant gloves. Use adequate ventilation for fumes. Failure to do so can result in a serious injury.



WARNING - LOCKOUT/TAGOUT

Make sure the machine has been locked out and tagged out in accordance to the machine’s documented procedures. Failure to do so may lead to serious injury or death.

This troubleshooting information assumes that the Hot Runner has been operational.

Basic rules for troubleshooting are:

- Define the problem; what is seen is only a symptom of the underlying problem.
- Develop a method to isolate the problem.
- Test one item at a time to verify results.
- Monitor the final solution to verify that the problem has been solved. Repeat occurrences of the same symptom may indicate other problems.
- Document the solution so that a repeat occurrence can be solved quickly.
- Consult other resources to augment the troubleshooting information in this manual.
- Use your resin supplier as one of the best resources available.

12.2 Moisture Related Issues

Many common molding issues can be directly attributed to moisture contamination of the production resin.

Generally, manufacturing resin is supplied from the manufacturer in ready to process pellets that are in sealed, airtight containers. Follow manufacturers storage instructions, keeping containers sealed until ready to use.

Prior to using pellets, follow the drying instructions, as provided by the resin supplier and molding machine manufacturer if applicable.

12.2.1 Resin Moisture Contamination

Moisture can be introduced into the resin in many ways:

- during transportation
- environmental exposure (aging)
- malfunctioning heater / dryer
- extreme humidity in atmosphere
- inadequate or malfunctioning facility HVAC

12.2.2 Resin Drying Issues

During the drying stage of the resin (if applicable), ensure that:

- the resin pellets are not overpacked
- adequate air circulation is present
- the drying system is properly sealed, according to manufacturers instructions

12.2.3 Importance of Pre-Drying Resin

Thermoplastic resins can be hygroscopic, able to absorb moisture from the air. Under normal processing conditions, this can lead to degradation of the polymer during molding. Breakage of polymer chains changes the properties, resulting in possible blisters, streaks, splay or other defects described in this section.

Recycled resins can have higher hygroscopic properties due to greater surface area and should be dried separately from fresh resins.

If moisture issues are ruled out, continue with the troubleshooting tables in the following pages.

12.3 Pre-Molding Precautions

Prior to commencing production, ensure that the following conditions have been met. This will greatly reduce any future need to troubleshoot defective production.

12.3.1 History

- Review any documentation associated with your batch job regarding the recipe using the mold, molding machine, thermoplastic resin, environmental setting, etc.
- Review comments, notes, logbooks, blogs and any other resource material that pertains to the batch job.
- Verify that all settings such as time, temperature, pressure, material, etc. are correct.

12.3.2 Material

- Ensure that the thermoplastic resin to be used is the right grade, and has been stored and / or prepared / dried, etc, according to manufacturer's specifications.
- Verify that the pigment / dye to be used meets manufacturer's specifications, and is compatible with the resin/molding machine / mold. Verify the correct recycle ratio and adjust settings accordingly.

12.3.3 Hardware

- Make sure the mold has been properly stored, and is dry, clean, free of rust, dirt, moisture, residual resin, pigment and any protective coating.
- Check that the temperature controller meets requirements and is fully tested and operational.
- The injection molding machine has been properly maintained, cleaned, lubricated; tolerances and dimensions verified.
- Make sure that the nozzles, cylinders, valves, gates, and any other variable that is appropriate for the batch job has been chosen.

12.3.4 Settings

Ensure that all batch job parameters are correct:

- temperatures
- pressures
- injection speed
- back pressure

12.4 Establishing Root Cause

This section is to be used as a reference tool only.

When a system that has been set up according to specification and was functioning normally suddenly produces sub-standard parts, the data in the following pages may be used to determine the possible cause, but only should be used as a guide.

A correct set up procedure that has been tested and confirmed will produce parts that meet design tolerances and specifications. A sudden change in any parameter indicates a possible fault. Rather than modify other settings to compensate for this variation, it is advisable to determine which of the original settings has changed.

12.4.1 Fault Identification

The operator will need to evaluate all the possible conditions which may have caused the defect.

- identify the problem
- determine the frequency
- is the problem random or in the same location
- review past history logs for similar occurrences and resolutions

Review the machine settings to ensure that there is no variation from the original setup which was producing standard parts.

- injection speed
- melt heating
- screw speed
- locking
- melt temperature
- cushion
- back pressure
- mold heating

For a more thorough analysis of the defect, refer to the following pages.

12.5 Troubleshooting Typical Problems

12.5.1 Dark Specks

The finished product contains dark specks. Usually occurs when transparent resins are used.

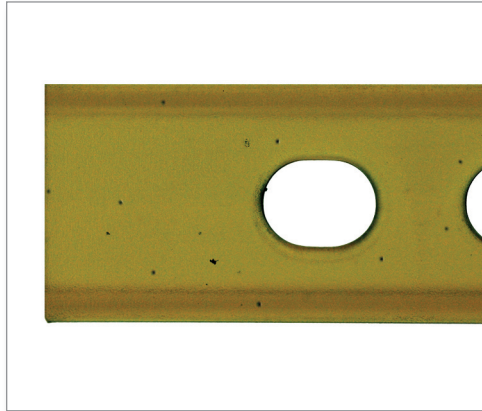

Probable Causes:

1. Molding Machine
 - Off-line for extended period
 - Barrel off-line for extended period
 - Barrel improperly purged
 - Contamination in plasticizer
 - Wrong nozzle
 - Use of wrong screw
2. Mold
 - Gate and / or runner has dead spots
3. Material
 - Physical contamination of raw material
 - Chemical contamination of raw material
 - Particulate contamination from machine barrel

Solution (in sequence):

1. Purge system with appropriate material
2. Trace source of contamination and repair, remove or discard
3. Adjust melt temperature if necessary
4. Inspect for dead spots: gates, runners, nozzle, back flow valve
5. Inspect feed screw for degradation

12.5.2 Blisters or Bubbles

The finished product contains small gas or air filled pockets or cooling voids.



Probable Cause:

1. Molding Machine
 - Low injection pressure
 - Back flow valve malfunctioning
 - Suck-back cycle too long
 - Rapid plasticizing
 - Trapped air in feed
 - Feed error
2. Mold
 - Trapped or volatile gas
 - Low mold temperature
 - Poor thin / thick transition phase
 - Inadequate venting
3. Material
 - Overheating of resin

Solution (in sequence):

1. Verify control and / or holding pressure
2. Increase back pressure
3. Increase mold temperature
4. Inspect back flow valve
5. Ensure proper venting
6. Increase gate size
7. Decrease vent land length

12.5.3 Flow Marks

The finished product exhibits blush and flow marks, due to variations in material temperature from gradients between the machine nozzle and mold sprue bushing. Cold material in the nozzle tip section results in a halo around the direct sprue.



Probable Cause:

1. Molding Machine
 - Wrong injection speed
 - Wrong injection pressure
 - Hold pressure too long
2. Mold
 - Insufficient mold cooling
 - Temperature of mold too high around the gate
 - Temperature of mold too cool
 - Gate size is too small
 - Gate is in wrong location
 - Land length of gate is too long
 - Incorrect Hot Runner system
3. Material
 - Melt temperature is too low

Solution (in sequence):

1. Adjust injection speed
2. Add a large cold slug area
3. Add cold wells at the end of the runner system
4. Use hot sprue bushing
5. Identify and eliminate dead pockets / sections

12.5.4 Burn Marks

The finished product display brown streaks. This is from the material being overheated due to trapped air (diesel effect), which can lighten or darken the color.

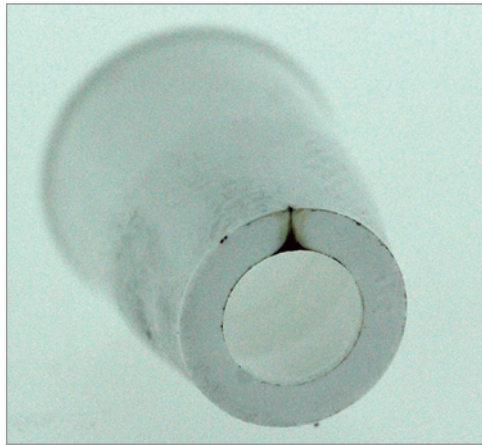

Probable Cause:

1. Molding Machine
 - High injection speed
 - Backflow / check ring valve malfunctioning
 - High back pressure
2. Mold
 - Trapped or volatile gas
 - Burning due to friction
 - Incorrect sprue diameter
3. Material
 - Overheated / underheated melt, possible shear

Solution (in sequence):

1. Clear blocked vent channels
2. Lower injection speed
3. Lower injection pressure
4. Check heater functionality
5. Check thermocouple functionality
6. Reduce feed screw rotation
7. Reduce melt temperature
8. Increase mold cavity venting
9. Enlarge gate
10. Change gate position and / or size

12.5.5 Delaminating Parts

The finished product is separating into layers that can be peeled off; surface layers are flaking off. Insufficient layer bonding as a result of high shear stresses; non homogeneous material.



Probable Cause:

1. Molding Machine
 - High injection speed
2. Mold
 - Cold mold
 - Gate has sharp corners
 - Sharp corners causing shear heat
3. Material
 - Physical contamination of raw material
 - Chemical contamination of raw material
 - Melt too hot / poor melt
 - Incompatible color dye
 - High percentage of recycled material

Solution (in sequence):

1. Increase melt temperature
2. Increase mold temperature
3. Decrease injection speed
4. Eliminate contamination
5. Adjust regrind ratio
6. Adjust or change resin moisture content
7. Purge system
8. Reduce sharp corners at gate

12.5.6 Dimensional Irregularities

The finished product is of a different dimensional value than originally designed, or previous production.

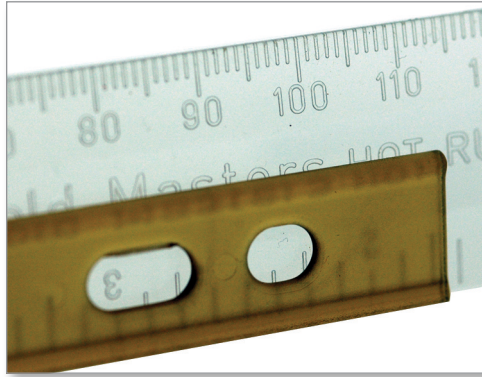

Probable Cause:

1. Molding Machine
 - Low injection pressure
 - Short hold pressure time
 - Damaged backflow / check ring valve
 - Short cycle time
 - Cylinder clearance too big
 - Nozzle heaters malfunctioning
2. Mold
 - Temperature setting too high
 - Small gate size resulting in wrong pressure
 - Incorrect gate location
 - Incorrect mold configuration / size
3. Material
 - Generally not a material related issue unless excessive regrind is used

Solution (in sequence):

1. Increase injection pressure
2. Increase cooling time
3. Increase mold temperature
4. Ensure cycle time is consistent
5. Monitor molding machine for irregularities
6. Balance regrind ratio
7. Increase gate size
8. Decrease gate land length
9. Balance the runner and / or gate system
10. Decrease cavity quantity

12.5.7 Discolored Parts

The finished product varies in color on different surfaces.

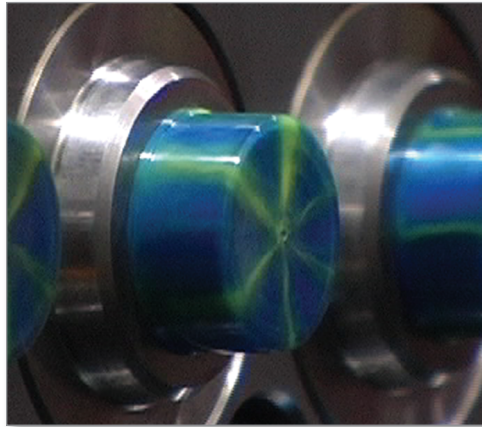

Probable Cause:

1. Molding Machine
 - Contamination
2. Mold
 - Incorrect sprue diameter
 - Inadequate venting
3. Material
 - Physical contamination of raw material
 - Chemical contamination of raw material
 - Melt too hot / poor melt
 - Incompatible color dye
 - Residence time too high

Solution (in sequence):

1. Purge heating cylinder
2. Lower resin temperature by:
 - reducing cylinder temperature
 - reducing screw speed
 - reducing back pressure
3. Decrease nozzle temperature
4. Adjust residence time
5. Adjust regrind ratio
6. Adjust cycle time
7. Check for external contamination sources
8. Ensure proper cooling in all areas
9. Increase mold venting

12.5.8 Flash

Also known as “fins” or “spew”. The finished product contains a thin film of material attached at the mold parting line.

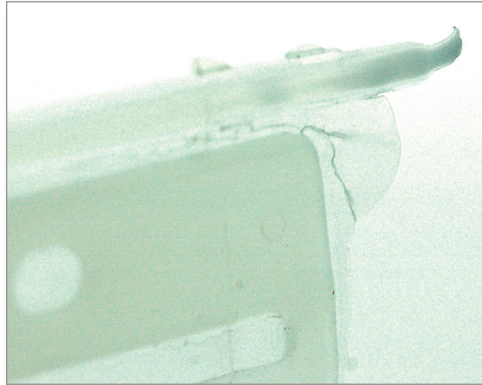

Probable Cause:

1. Molding Machine
 - Low clamping pressure
 - High injection pressure
 - High injection speed
2. Mold
 - Inadequate mold supports
 - Low clamping force
 - Damaged mold
 - Projected area too large for machine capacity
3. Material
 - Low melt viscosity
 - High melt temperature

Solution (in sequence):

1. Reduce the injection speed
2. Reduce the injection pressure
3. Reduce the injection time
4. Increase clamping force
5. Inspect the mold for irregularities
6. Reduce the melt temperature
7. Inspect vent depth
8. Switch to higher tonnage clamping machine
9. Establish correct transfer position
10. Reduce hold pressure

12.5.9 Jetting

The finished product exhibits serpentine flow patterns on the surface as a result of the melt cooling prior to complete filling of the mold.



Probable Cause:

1. Molding Machine
 - High injection speed
2. Mold
 - Cold mold
 - Small gate
 - Wrong gate land length
 - Wrong gate location
3. Material
 - Cold melt

Solution (in sequence):

1. Decrease injection speed
2. Verify nozzle temperature
3. Increase mold temperature
4. Increase melt temperature
5. Increase gate size
6. Modify gate location

12.5.10 Pitted Parts

The finished product contains unmelted particles or small holes on the surface.

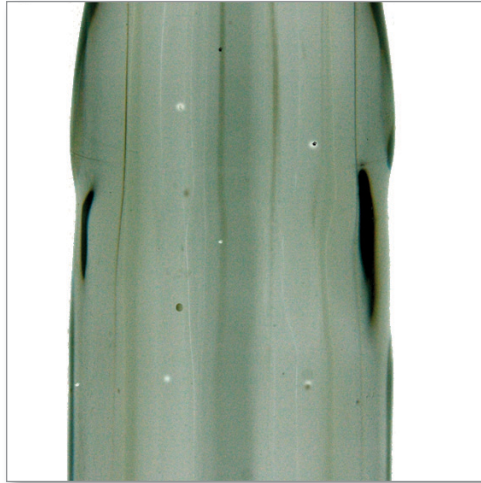

Probable Cause:

1. Molding Machine
 - Improper or worn out feed screw
 - Low melt temperature
 - Low injection speed
2. Mold
 - Gating shear
 - Sharp corners
3. Material
 - Resin used is not homogeneous
 - External contamination

Solution (in sequence):

1. Reduce shear
2. Reduce back pressure
3. Reduce injection speed
4. Modify temperature
5. Modify regrind ratio
6. Modify shot size
7. Inspect Hot Runner and nozzles

12.5.11 Rough Surface

The finished product exhibits patterns on the surface similar to grooves on a record, due to rapid cooling of the melt as it nears mold surface, followed over and over again by fresh melt.



Probable Cause:

1. Molding Machine
 - Low injection speed
 - Low injection pressure
2. Mold
 - Cold mold
 - Irregularities in mold surface, defective polishing
3. Material
 - Cold melt

Solution (in sequence):

1. Increase injection speed
2. Increase injection pressure
3. Increase melt temperature
4. Increase mold temperature
5. Inspect mold surface

12.5.12 Parts Sticking to Cavity

The finished product does not properly release from the mold (female side).

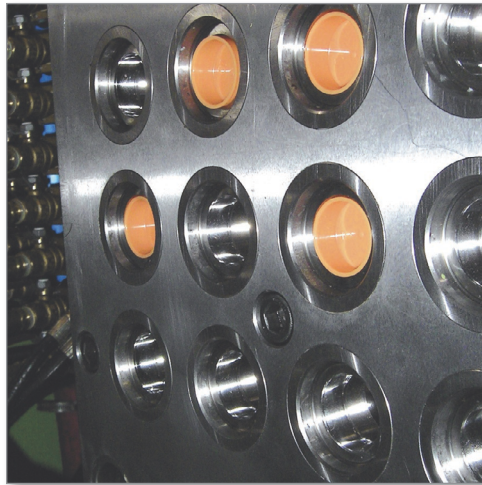

Probable Cause:

1. Molding Machine
 - High injection pressure
 - High injection speed
 - Long holding time
 - High material feed
2. Mold
 - Hot cavity
 - Cold mold
 - Defective mold surface
3. Material
 - Melt too hot

Solution (in sequence):

1. Confirm cycle time for cooling
2. Reduce injection pressure
3. Reduce injection hold time
4. Reduce injection speed
5. Reduce injection time
6. Adjust feed
7. Inspect mold finish
8. Increase mold opening cycle
9. Lower mold temperature
10. Adjust differential temperatures
11. Inspect for appropriate mold release

12.5.13 Parts Sticking to Core

The finished product does not properly release from the mold (male side).

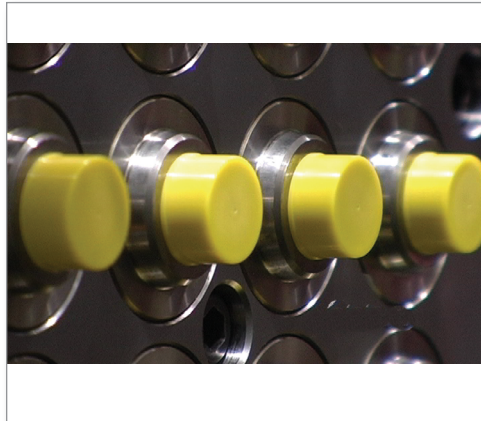

Probable Cause:

1. Molding Machine
 - High injection pressure
2. Mold
 - Hot core
 - Bending of core
 - Presence of vacuum
3. Material
 - Generally not a material related issue

Solution (in sequence):

1. Confirm cycle time for cooling
2. Reduce injection pressure
3. Reduce injection hold time
4. Reduce injection time
5. Adjust feed
6. Reduce mold closed time
7. Increase core temperature
8. Decrease nozzle temperature
9. Inspect mold for undercuts and / or improper draft
10. Verify mold bending ratio

12.5.14 Short Parts

The finished product is not completely formed.



Probable Cause:

1. Molding Machine
 - Bad feed
 - Low injection pressure
 - Low injection speed
 - Short injection time
 - Back flow valve / check ring faulty
 - Improper venting
2. Mold
 - Insufficient venting
 - Cold mold
3. Material
 - Low melt temperature
 - Viscous material

Solution (in sequence):

1. Increase feed
2. Increase injection pressure
3. Increase feed temperature by increasing cylinder temperature
4. Increase injection time
5. Increase mold temperature
6. Increase nozzle diameter
7. Inspect for restrictions
8. Increase gate size of sprue and runner system

12.5.15 Sinks or Voids

The finished product has hollows and pockets in areas that do not cool sufficiently, causing contraction.

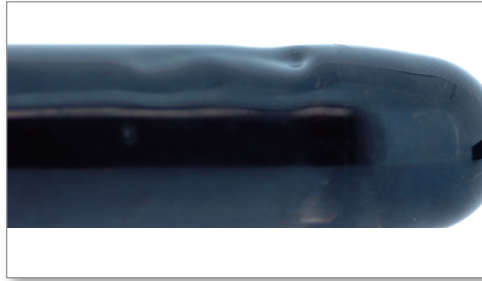

Probable Cause:

1. Molding Machine
 - Low injection pressure
 - Short injection time
 - Insufficient material in cavity
 - High injection speed
 - Low back pressure
 - Damaged backflow valve / check ring
2. Mold
 - Mold not at required temperature
 - Small gate leading to early freezing
 - Gate land length too long
 - Incorrect rib / wall dimensions
 - Material flow incorrect
 - Thick wall part
3. Material
 - Hot material
 - Material wrong grade for application

Solution (in sequence):

1. Adjust injection speed
2. Increase injection hold time
3. Increase injection pressure
4. Adjust melt temperature
5. Adjust mold temperature
6. Inspect for hot spots
7. Enlarge and / or add vents to mold parting line
8. Increase sprue or runner size
9. Increase gate size / reduce gate land length
10. Relocate gate closer to heavy / thicker areas
11. If possible, core out heavy wall sections

12.5.16 Splay

The finished product display splay / splash marks and/or silver streaks.



Probable Cause:

1. Molding Machine
 - Resin degraded from overheating
 - Cylinder contains hot spots
 - Material trapped at nozzle tip
 - Wrong injection pressure
 - Wrong injection speed
 - Low back pressure
2. Mold
 - Friction related burning in gate, nozzle or Hot Runner
 - Trapped volatile compounds
3. Material
 - Hot melt
 - Contaminated resin (moisture, dirt, organics)
 - Degraded resin

Solution (in sequence):

1. Dry resin according to procedure; check drying equipment for functionality
2. Reduce nozzle temperature
3. Reduce material temperature:
 - lower cylinder temperature
 - reduce screw speed
 - reduce back pressure
4. Decrease injection speed
5. Increase mold temperature
6. Decrease or eliminate screw decompression
7. Reduce cycle time
8. Check for drooling
9. Check for contamination in mold cavity
10. Open gates
11. Try mold in smaller shot-size press

12.5.17 Streaks

The finished product has large, dull and laminate appearance areas on the surface.



Probable Cause:

1. Molding Machine
 - Back flow valve ring damaged
2. Mold
 - Hot spots
 - Material trapped in certain areas
3. Material
 - Contamination of resin or machine
 - If pattern is identical, cause may be the machine
 - If pattern is erratic, cause may be the material or coloring
 - Degraded or unstable material

Solution (in sequence):

1. Check for contamination
2. Check barrel purging
3. Inspect back flow ring for wear or cracks
4. Inspect feed screw for wear and tear
5. Inspect screw / barrel for tolerances
6. Verify heater operation
7. Verify thermocouple operation

12.5.18 Stringing

The finished product has thin plastic strings attached to the sprue.

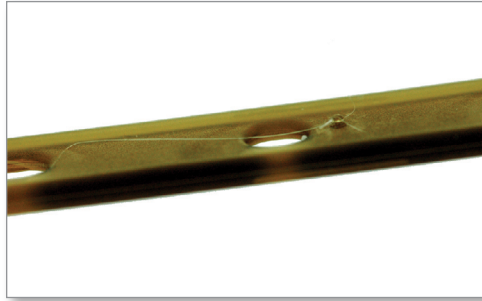

Probable Cause:

1. Molding Machine
 - High back pressure
 - High nozzle temperature
2. Mold
 - Incorrect sprue
3. Material
 - Melt strength inadequate

Solution (in sequence):

1. Reduce back pressure
2. Modify nozzle temperature
3. Modify temperature profile
4. Eliminate sprue breaks
5. Increase cooling time
6. Decrease mold temperature at the gate

12.5.19 Warped Parts

The finished product has pressure differences / stress on its surface, causing the part to be disfigured

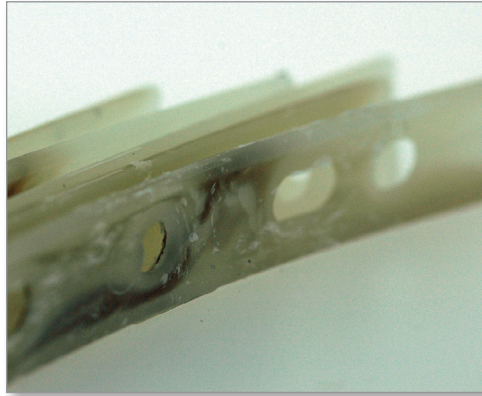

Probable Cause:

1. Molding Machine
 - Wrong cooling time
 - High injection pressure
2. Mold
 - Gate located in wrong area
 - Undercuts too big
 - Cavity too hot
 - Part is wrong design or too heavy
3. Material
 - Fillers have wrong orientation
 - Incorrect material

Solution (in sequence):

1. Ensure temperature in both mold halves is equal
2. Monitor part ejection from mold for uniformity
3. Monitor part handling following ejection
4. Verify part weight following ejection
5. Increase injection hold time
6. Increase cooling time
7. Adjust injection pressure
8. Adjust mold temperature; set sequential temperatures based on part geometry
9. Check gate dimensions, quantities and locations
10. Re-design part if necessary

12.5.20 Weld Lines

The finished product has lines where two flow fronts meet and have not fused, creating the possibility of weak areas and stress fractures.

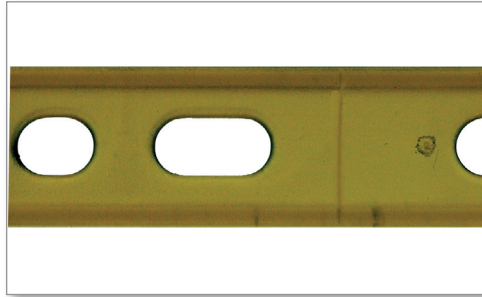

Probable Cause:

1. Molding Machine
 - Low injection speed
 - Low injection pressure
 - Short injection time forward
2. Mold
 - Low mold temperature
 - Poor venting
 - Back flow valve / check ring malfunctioning
 - Gates too far apart
 - Redesign part
3. Material
 - Cold melt
 - Material wrong grade for application

Solution (in sequence):

1. Increase injection pressure
2. Increase injection holding time
3. Increase injection speed
4. Increase cylinder temperature
5. Increase mold temperature
6. Check for venting
7. Provide an overflow well adjacent to the weld area
8. Modify the gate location
9. Decrease gate land length

Index

Symbols

4/2 directional valve element...11-7, 11-8, 11-9, 11-10, 11-11

A

anti-rotation piston
 63 mm diameter assembly
 assembling...4-32
 80 mm assembly
 assembling...4-35
 assemblies
 installing on manifold...5-29
 assembly...5-1
 FSG3 drop-in system...5-2
 Fusion-lite system...5-2
 typical Fusion system...5-1
 waterless hydraulic and pneumatic actuators...5-38

B

blisters...12-6
 bubbles...12-6
 burn marks...12-8

C

cleaning...4-2
 color change...10-1
 for hot tip / sprue system...10-1
 for valve gate system...10-2
 contamination
 locating the source of...10-2
 core to manifold fit
 checking...5-4
 cylinder
 anti-rotation waterless...4-23
 assembling...4-38

D

dark specs...12-5
 de-burring a gate...5-37
 delaminating parts...12-9
 dimensional irregularities...12-10
 discolored parts...12-11
 disposal...3-12
 document release details...1-1

E

electrical safety testing...7-2
 fault loop impedance...7-3
 insulation resistance test...7-2
 protective bonding circuit...7-2

electrical testing...7-1
 functional test with controller...7-4
 heating element check...7-4
 retesting...7-4
 thermocouple continuity test...7-3

F

fittings
 hydraulic...11-13
 maintenance schedule...11-14
 flange
 installing in inlet...5-20
 flash...12-12
 flexible heaters
 field replacement of...11-3
 flow control valve
 hydraulic
 installing...5-49
 flow marks...12-7

G

gate
 de-burring...5-37
 gate seal and nozzle assembly
 checking fit...5-15
 installing gate seal on nozzle...5-16
 gate seal finishing...5-3

H

hazard areas...3-2
 headless valve pin
 extracting...11-17
 heater
 tubular...11-3
 installing...11-4
 removing...11-3
 starting up...11-6
 storing...11-3
 heater continuity...7-3
 heating element check...7-4
 hoses
 hydraulic
 maintenance schedule...11-13
 hot runner
 single nozzle...5-51
 assembling...5-51
 assembling heater sleeve...5-53
 assembling heater sleeve and nozzle...5-53
 installing nozzle in back plate...5-52
 installing nozzle in plate...5-55
 hydraulic actuator
 adjusting the stroke...4-8
 adjusting the valve pin position...4-9
 waterless
 assembling...5-38

hydraulic flow control...8-6
hydraulic flow-control valve
 connections...5-50
 installing...5-49
hydraulic solenoid valve bank...11-7

I

inlet
 thermocouple
 installing...5-22
 with flange
 installing...5-20
inlet extension
 checking core-del to manifold fit...5-25
 tip
 installing...5-23
 without flange...5-25
 installing...5-25
 installing nozzle heaters and sleeves...5-25
installation...8-1
 manifold locator dowel...8-2
 pre-installation...8-2
 unpacking...8-1
insulation resistance test...7-2

J

jetting...12-13

M

maintenance...11-1
manifold locator
 installing...5-17
manifold thermocouple
 installing...5-19
manometer mounting port...11-8
manual override pin...11-8
manual override switch...11-12
marks
 burn...12-8
 flow...12-7
moisture issues...12-2

N

nozzle
 assembling
 systems without protective sleeves...5-12
 systems with protective sleeves...5-7
 installing in manifold...5-6

P

part defects...12-5
 blisters...12-6
 bubbles. See blisters
 burn marks...12-8
 dark specks...12-5
 delaminating...12-9

dimensional irregularities...12-10
discolored parts...12-11
flash...12-12
flow marks...12-7
jetting...12-13
parts sticking to cavity...12-16
parts sticking to core...12-17
pitted parts...12-14
rough surface...12-15
short parts...12-18
sinks...12-19
splay...12-20
streaks...12-21
stringing...12-22
voids. See part defects, sinks
warped parts...12-23
weld lines...12-24
pinch point test...7-3
pitted parts...12-14
plumbing cylinders...5-45
pneumatic actuator...4-10
 adjusting the stroke...4-15
pneumatic solenoid valve bank...11-10
preparation...4-1
pressure reducing and relieving valve...11-7
pre-startup...9-1
protective bonding circuit...7-2

R

resin
 contamination...12-2
 drying issues...12-2
retesting...7-4
re-torquing...5-4
returned goods policy...1-2
rough surface...12-15

S

safety...3-1
 FSG3...3-13
 hazard areas...3-2
 hazards...3-2
 lockout...3-10
 symbols...3-7
safety symbols
 general descriptions...3-7
screw lengths...4-1
seals
 hydraulic...11-13
 maintenance schedule...11-14
service. See support
SeVG+...6-1
SeVG+ actuator...6-1
short parts...12-18
shutdown...9-3

- single-nozzle hot runner. See hot runner, single nozzle
- sinks...12-19
- solenoid connector...11-9
- solenoid form C connector...11-12
- solenoid valve bank...11-6
 - hydraulic...11-7
 - pneumatic...11-10
- solenoid valve wiring...5-44
- spare parts...11-16
 - recommended...11-16
- splay...12-20
- startup...9-2
 - pre-...9-1
- streaks...12-21
- stringing...12-22
- support...2-1
- support bushings
 - installing...5-17
- system test...8-5

T

- tapered valve pin. See valve pin, tapered
- test
 - system...8-5
- thermocouple continuity test...7-3
- tools required...4-1
- torque settings...11-1
- troubleshooting...12-1
- tubular heater...11-3
 - installing...11-4
 - starting up...11-6

U

- unpacking...4-2

V

- valve bank assembly...11-10
- valve disk
 - installing...5-26
- valve element TC08...11-10
- valve insert
 - installing...5-26
- valve pin
 - headless
 - extracting...11-17
 - tapered
 - calculating preload...5-36
 - cleaning valve pin and runner...5-34
 - finding lap...5-31
 - honing...5-32
 - lapping...5-32
 - timing...5-36
- valve pin position monitoring...8-6
- voids...12-19

W

- warped parts...12-23
- warranty...1-1
- water-cooled gate insert
 - installing...5-3
- waterless actuator...4-16, 4-24
- waterless hydraulic actuator
 - assembling...5-38
- waterless pneumatic actuator...4-24
 - adjusting the valve pin length...4-26
 - assembling the cylinder...4-31
 - assembling the cylinder body...4-27
 - assembling the piston...4-25
- weld lines...12-24
- wire armor
 - installing on manifold...5-42
 - installing wiring...5-43
 - plumbing cylinders...5-45
 - solenoid valve wiring...5-44
- wiring check...3-8



Scan the QR code for our global contacts: